

Thank you for selecting the **ZOOM 503** (hereafter simply called the "**503**").

Please take the time to read this manual carefully so you can get the most out of your 503 and ensure optimum performance and reliability.

Retain this manual for future reference.

ZOOM CORPORATION

NOAH Bldg., 2-10-2, Miyanishi-cho, Fuchu-shi, Tokyo 183-0022, Japan
PHONE: 0423-69-7116 FAX: 0423-69-7115

Printed in Japan 503-5000





1 Features

- Compact multi-effect device convincingly recreates the sound of famous guitar or bass amplifiers. This is ideal for line recordings to a tape recorder or when playing your instrument via a hi-fi audio system. It also lets a fairly small guitar or bass amplifier sound more powerful and dynamic.
- Integrated amp simulator gives a wide choice of guitar/bass amplifier characteristics. Sophisticated cabinet simulator allows control over cabinet size, ringing, and even simulated microphone position. This makes it easy to create exactly the sound you want.
- Two input jacks with different sensitivity enable optimum matching to any guitar or bass, including instruments with single-coil magnetic pickups or active pickups.
- Ten types of high-quality effects such as chorus, delay, and reverb produce realistic ambience.
- You can switch between 24 patches to store diverse settings based on your preference.
- Integrated auto-chromatic tuner for guitar. You can tune your instrument easily anywhere, any time. You can also leave the tuning function disabled all the time.
- AUX input allows connecting the output of audio components such as a CD player, for mixing with the instrument signal.
- Dual power supply design allows the unit to be powered from a 9V alkaline battery (6LR61) or an AC adapter.

2 Safety Precautions

USAGE AND SAFETY PRECAUTIONS

In this manual, symbols are used to highlight warnings and cautions for you to read so that accidents can be prevented. The meanings of these symbols are as follows:

-  **Warning** This symbol indicates explanations about extremely dangerous issues. If users ignore this symbol and handle the device incorrectly, serious injury or death could result.
-  **Caution** This symbol indicates explanations about dangerous issues. If users ignore this symbol and handle the device the wrong way, bodily injury and damage to the equipment could result.

Please observe the following safety tips and precautions to ensure hazard-free use of the 503.

About power

Warning Since power consumption of this unit is fairly high, we recommend the use of an AC adapter whenever possible. When powering the unit from a battery, use only an alkaline type.

AC adapter operation

- Be sure to use only an AC adapter which supplies 9 V DC, 300 mA and is equipped with a "center minus" plug (Zoom AD-0006). The use of an adapter other than the specified type may damage the unit and pose a safety hazard.
- Connect the AC adapter only to an AC outlet that supplies the rated voltage required by the adapter.
- When disconnecting the AC adapter from the AC outlet, always grasp the adapter itself and do not pull the cable.
- If the unit is not to be used for a long time, disconnect the AC adapter from the outlet.

Battery operation

- Use only a 9 V (alkaline) battery (6LR61).
- The 503 cannot be used for recharging. Pay close attention to the labelling of the battery to make sure you choose the correct type.
- If the 503 is not to be used for an extended period of time, remove the battery from the unit.
- If battery leakage has occurred, wipe the battery compartment and the battery terminals carefully to remove all remnants of battery fluid.
- While using the unit, the battery compartment cover should be closed.

Environment

Caution Avoid using your 503 in environments where it will be exposed to:

- Extreme temperature
- High humidity or moisture
- Excessive dust or sand
- Excessive vibration or shock

Handling

Caution The 503 is a precision instrument. Except for the foot switches, do not push other parts with your feet or subject them to strong force.

- Take care that no foreign objects (coins or pins etc.) or liquids enter the unit.
- Be sure to turn the power to all equipment off before making connections.
- Before moving the unit, turn the power off and disconnect all cables and the AC adapter.

Alterations

Caution Never open the case of the 503 or attempt to modify the product in any way since this can result in damage to the unit.

Usage precautions

Electrical interference

For safety considerations, the 503 has been designed to provide maximum protection against the emission of electromagnetic radiation from inside the device, and from external interference. However, equipment that is very susceptible to interference or that emits powerful electromagnetic waves should not be placed near the 503, as the possibility of interference cannot be ruled out entirely.

Whatever the type of digital control device, the 503 included, electromagnetic damage can cause malfunctioning and corrupt or destroy data. Since this is an ever-present danger, thorough care should be taken to minimize the risk of damage.

Cleaning

Use a soft, dry cloth to clean the 503. If necessary, slightly moisten the cloth. Do not use abrasive cleanser, wax, or solvents (such as paint thinner or cleaning alcohol), since these may dull the finish or damage the surface.

Connecting cables and input and output jacks

You should always turn off the power to the 503 and all other equipment before connecting or disconnecting any cables. Also make sure to disconnect all cables and the AC adapter before moving the 503.

3 What Are Banks and Patches?

• PATCH

A group of the settings for a certain effect type is called a PATCH. The 503 comes with 24 preset patches which can be changed (edited) by the user.

• BANK

The 503 calls up patches in sets of four, called a "bank".

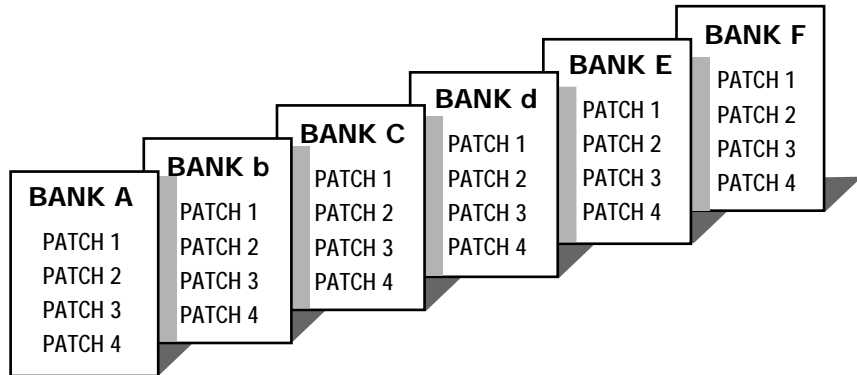

4 PATCH LIST

The 503 has memory capacity for 24 patches. At the factory, these are programmed with recommended settings.

The user can Edit and Store any patch, and also restore the factory settings.

* The patches of banks A and b can be used for line playback by setting the cabinet simulator to ON.

* The ZNR (Zoom Noise Reduction) parameter in each patch should be adjusted for optimum matching with your guitar or bass.

PATCH NAME	AMP TYPE	DESCRIPTION
BANK A for GUITAR Settings for use with a guitar amplifier		
1 900-DRIVE	MS DRIVE	Smooth distortion covers entire range from backing to lead play
2 TWIN-LEAD	F DRIVE	Hard F-AMP sound suitable for blues leads
3 BOX-BEAT	VX CRUNCH	Liverpool sound at its best
4 MKIII-CHORUS	BG DRIVE	Solid BG AMP distortion enhanced by a rich chorus
BANK b for GUITAR Settings for use with a guitar amplifier		
1 ROCK LEAD	PV DRIVE	Rock lead sound with a powerful amplifier drive
2 SWEET BOX	BG DRIVE	Sweet sounding sound enhances any type of play
3 JETS	MS DRIVE	Jet sound with effective flanger action
4 NUANCE CRUNCH	MS CRUNCH	Crunch sound ideally matched to single-coil pickups
BANK C for GUITAR Settings for creating a guitar amplifier sound in a line playback system		
1 WILD-DIST	PV DRIVE	Wild and hard driving sound for heavy rock
2 STRAIGHT BACK	MS CRUNCH	Imposing crunch sound for a variety of styles
3 HARDIST	MS DRIVE	Rock lead sound tailored for line playback
4 TREMOLO CLEAN	F CLEAN	Vintage amplifier style clean sound with tremolo
BANK d for GUITAR Settings for matching line playback to CD or synthesizer sources		
1 STUDIO LEAD	BG DRIVE	Simulates the lead sound of L.A. recording studios
2 LIGHT CRUNCH	VX CRUNCH	Crunch sound varies with picking intensity
3 FUSION 335	BG DRIVE	Fusion type sound simulates box ringing
4 BACK&SOLO	J CLEAN	Almighty clean sound with effective flavor
BANK E for BASS Settings for use with a bass amplifier		
1 ROCK BASS MAN	F DRIVE	Bass amplifier drive sound simulation
2 SW "SLAP" R	SW CLEAN	Realistic sound suitable for stepping and finger sound
3 BASS BOOSTER	F DRIVE	Lightly boosted refined sound
4 TRACE STANDARD	TE CLEAN	Standard type sound with a distinctive edge
BANK F for BASS Settings for line playback		
1 LINE SLAP	SW CLEAN	Slap sound suitable for line recording
2 SOLO PLAY	AC DRIVE	Rich and savory sound for impressive solo playing
3 WALKING	TE CLEAN	Professional sound for running bass lines
4 MELODY	TE CLEAN	Mellow sound for melodious solos

5 Configuration of Effects

The patches of the 503 are created using the four modules (effects) listed below. You can imagine such a module as a box containing various effect settings. Each module has several parameters which determine its sound. The parameters can be adjusted, just as you can turn the knobs on a single compact effect device. A set of changed parameters can be stored as a patch for later recall.

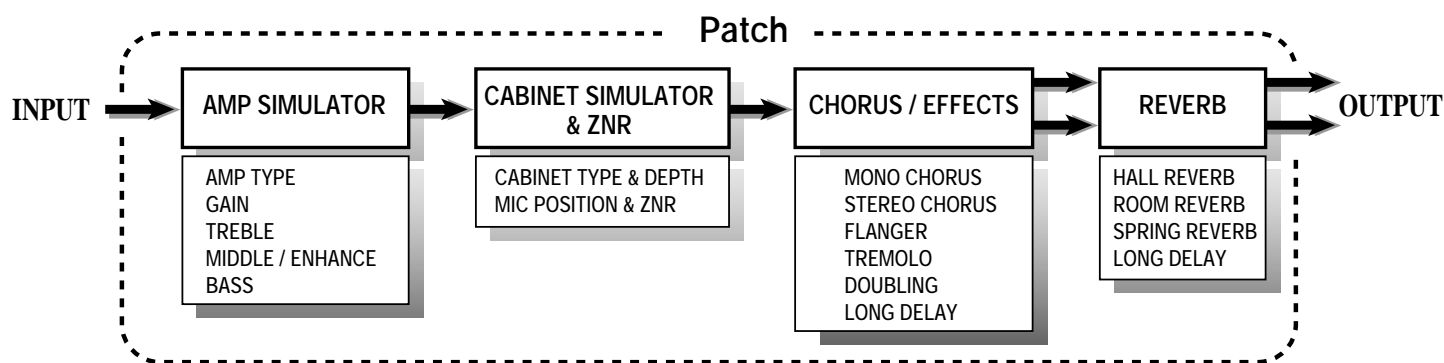

• AMP SIMULATOR

Controls the amp simulator type, gain, and 3-band equalization (TREBLE/MIDDLE/BASS). The MIDDLE parameter can also be used to obtain an enhancer effect.

• CABINET SIMULATOR & ZNR

Controls the cabinet simulator type, the simulated mike position, and the ZNR (Zoom Noise Reduction) settings.

• CHORUS/EFFECTS

Adds chorus, flanger, delay and other effects to change the sound character.

• REVERB

Allows the choice between three types of reverb (hall, room, spring), to create a feeling of ambience.

6 Controls, Functions and Connections

Top Panel

TUNER indicator

- Play mode:** Indicator lights up when the Reverb module is on for the currently selected patch.
- Bypass(Mute)/Tuner mode:** Indicator flashes to show that tuning function is active. It also serves as center indicator for fine tuning.
- Edit mode:** Indicator flashes when REVERB parameter is selected.
- BATTERY EMPTY WARNING display** When the unit is powered from the battery and the battery is running low, this indicator begins flashing at a faster rate than in Edit mode. In such a case, replace the battery as soon as possible.

STORE key

- When the contents of patches are to be stored, this key is used for putting the unit in store standby status and to execute the store function.
- Setting of direct load function** When the STORE key is pressed for at least 1 second during Play mode (during performance), the direct load function can be switched on or off. [For details, see 10 Patch Switching (Application: Direct Load OFF).]

EDIT key (for creating your own patches)

- This key serves to toggle between the Play mode and Edit mode (mode for creating patches to suit your taste).
- In Edit mode, this key can be used to select the effect parameters you wish to change. Also, when the effect parameter LEVEL is selected, press this EDIT key to return from the Edit mode to the Play mode.
- Setting of bank hold function** When the EDIT key is held down for at least 1 second in Play mode, the bank hold function is turned on or off. [For details, see 9 Patch Switching (Application: Bank Hold ON).]

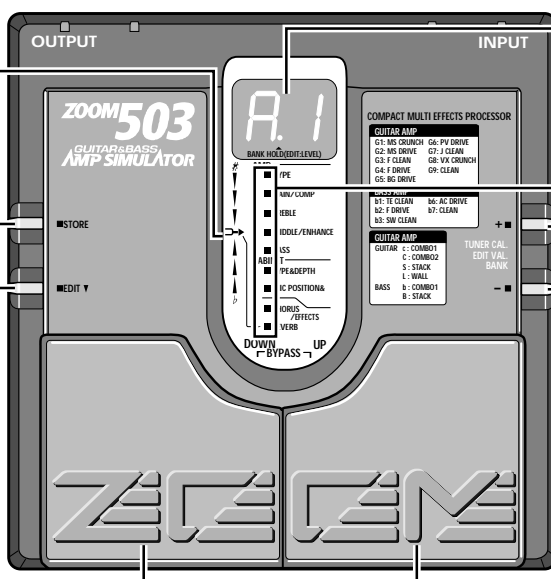

DISPLAY

- Displays information required to operate the 503.
- Play mode** Displays the selected bank (A-F) and patch (1-4).
- Edit mode** Displays the value of the selected effect parameter. In Edit mode, when the LEVEL parameter (patch volume level) is selected, the dot (.) in the center of the display flashes.
- Bypass(Mute)/Tuner mode** Shows the pitch of the input signal.

PARAMETER CURSOR indicator

- Play mode** The currently used effect module lights.
- Edit mode** The indicator lights up for the currently used effect module, and the indicator flashes for the effect module that is turned off. Also, the indicator for the effect module selected for editing flashes.
- Bypass(Mute)/Tuner mode** Indicators function as tuning meter.

VALUE +/- keys

- Play mode** The keys serve for bank switching.
- Edit mode** The keys serve for changing the effect parameter.
- Bypass(Mute)/Tuner mode** The keys serve for setting the tuner reference pitch (calibration).

PATCH UP (right)/DOWN (left) pedals

- Play mode** The pedals serve for patch switching. Pressing both pedals simultaneously activates the Bypass(Mute)/Tuner mode.
- Edit mode** The pedals serve for selecting effect parameters. Pressing both pedals simultaneously turns the currently selected effect module on or off.
- Bypass(Mute)/Tuner mode** Pressing either pedal cancels the Bypass(Mute)/Tuner mode to return to Play mode.

AUX IN jack

The output connector (stereo mini phone jack) of an audio component can be connected here. By connecting for example a portable CD player/cassette deck, the sound can be mixed with the sound from the guitar or bass. The mixed signal is supplied to the OUTPUT jack. Adjust the level of the mixed signal at the output component.

OUTPUT jack

The output of the 503 is this jack. A shielded Y cable can be used for input to a stereo component such as a tape recorder, or a stereo headphone can be connected directly. A headphone will let you enjoy realistic guitar amp sound even late at night. If the volume level from the headphones is low, use phones with low impedance (32 ohms or less). The output can of course also be connected to a guitar amplifier or bass amplifier using a shielded mono cable.

Rear Panel

INPUT jacks

Serve for connection of the guitar or bass. Choose the HIGH or LOW input, according to the output level of the instrument pickup. For instruments with active pickups and built-in preamplifier and for humbucking type pickups, use the LOW input. For other instruments, use the HIGH input. When the unit operates on batteries, the INPUT jack doubles as a power switch. Plugging in a shielded cable turns the 503 on. To prevent draining the battery, unplug the cable when the unit is not in use.

DC IN (AC adapter) jack

Serves for connecting an AC adapter (Zoom AD-0006) which delivers 9 VDC, 300 mA with a "center minus" plug configuration. The 503 is powered on by plugging an AC adapter into this jack.

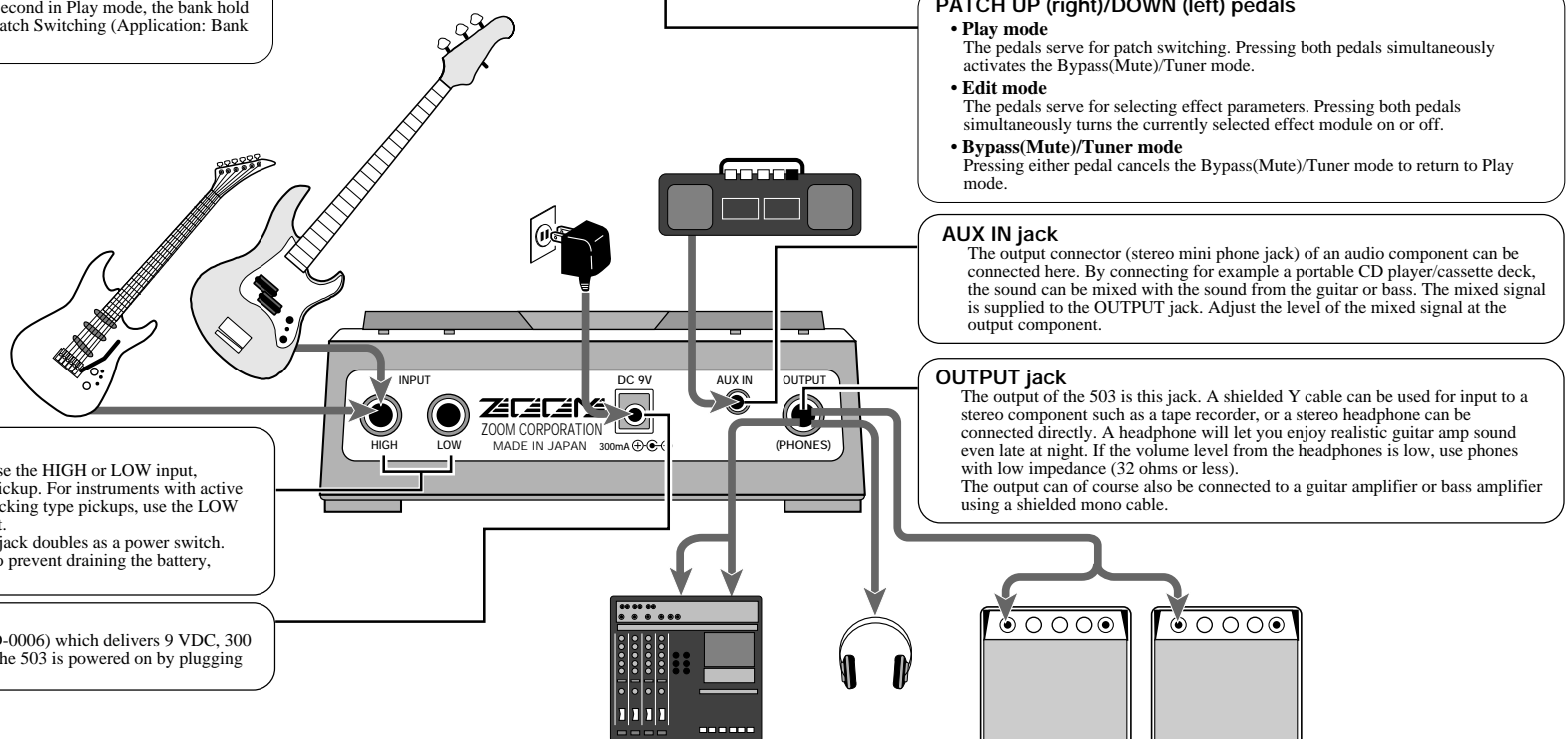

7 Selecting Patches

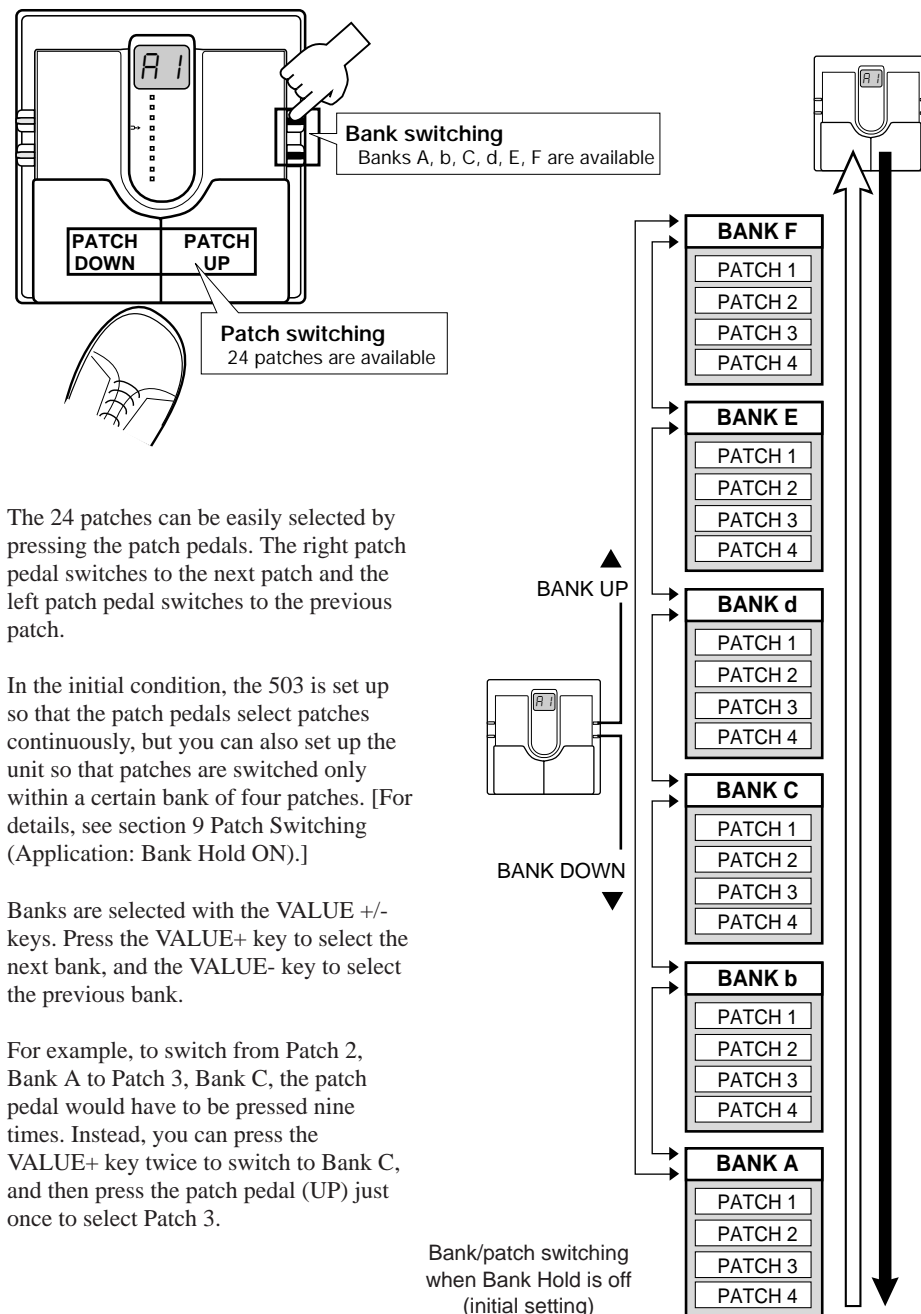

The 24 patches can be easily selected by pressing the patch pedals. The right patch pedal switches to the next patch and the left patch pedal switches to the previous patch.

In the initial condition, the 503 is set up so that the patch pedals select patches continuously, but you can also set up the unit so that patches are switched only within a certain bank of four patches. [For details, see section 9 Patch Switching (Application: Bank Hold ON).]

Banks are selected with the VALUE +/- keys. Press the VALUE+ key to select the next bank, and the VALUE- key to select the previous bank.

For example, to switch from Patch 2, Bank A to Patch 3, Bank C, the patch pedal would have to be pressed nine times. Instead, you can press the VALUE+ key twice to switch to Bank C, and then press the patch pedal (UP) just once to select Patch 3.

8 Using the Bypass (Mute)/Tuner Mode

In the Bypass mode, the effects of the 503 are temporarily turned off, so that the original sound of the instrument only is heard. In this mode, the auto-chromatic tuning function is also active. It is also possible to activate muting, to prevent the tuning sound from being sent to the output.

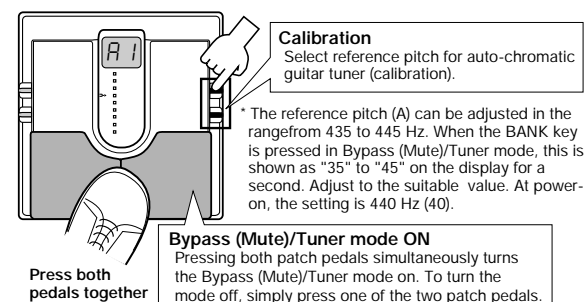

Bypass and mute condition

Pressing both patch pedals simultaneously activates the Bypass or Mute mode.

- **For bypass mode:** Press and immediately release the patch pedals.

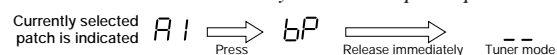

- **For mute mode:** Press patch pedals for at least 1 second.

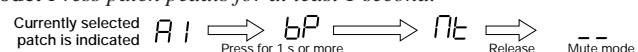

To cancel the bypass or mute condition, simply press one of the patch pedals. The unit then reverts to the previously selected patch.

Tuner mode

The 503 is initially set so that the auto-chromatic tuning function for the guitar activates automatically when the Bypass(Mute) mode is invoked. In Bypass(Mute) mode, pick an open string to be tuned. The closest note will be shown on the display.

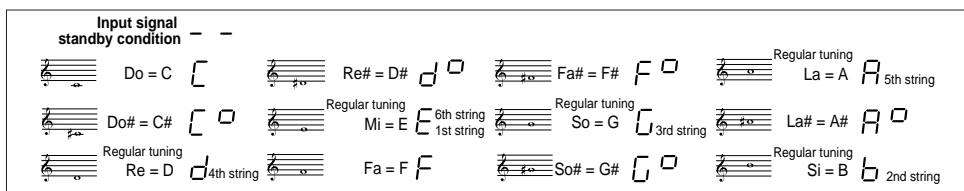

When the tuning function is active, the parameter cursor LEDs serve as tuning meter, designed to enhance tuning precision during fine adjustments.

Turning tuning function off

If you do not want to activate the tuning function in Bypass(Mute) mode, press the STORE and EDIT keys simultaneously for more than one second in Play mode. The tuning function will be turned off, and this setting will be stored even when the power is turned off. When you turn the function off, the display will show "tunEr oFF" (tuning function off).

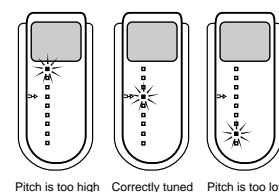

To turn the tuning function on, press the same keys simultaneously again. The display will show "tunEr on" (tuning function on).

NOTE: • Please note that the tuning function may not operate properly if other effect modules between the guitar and the 503 are on.
• To tune a bass, use 12th-fret harmonics.

9 Patch Switching (Application: Bank Hold ON)

In the initial setting, the patch pedal switches all patches in order, regardless of the bank divisions.

The bank hold function limits switching to the four patches within a bank. When this function is activated, the patch pedals switch in order between the patches in the current bank only.

To activate this function, hold the EDIT key down for at least 1 second in Play mode. The BANK HOLD indicator will light. To turn the function off, again hold the EDIT key down for at least 1 second. The BANK HOLD indicator will go off.

Banks can be switched using the VALUE +/- keys.

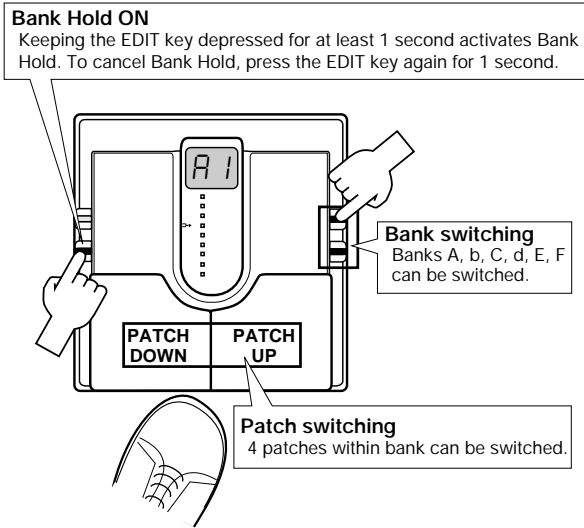

Bank/patch switching when Bank Hold is on

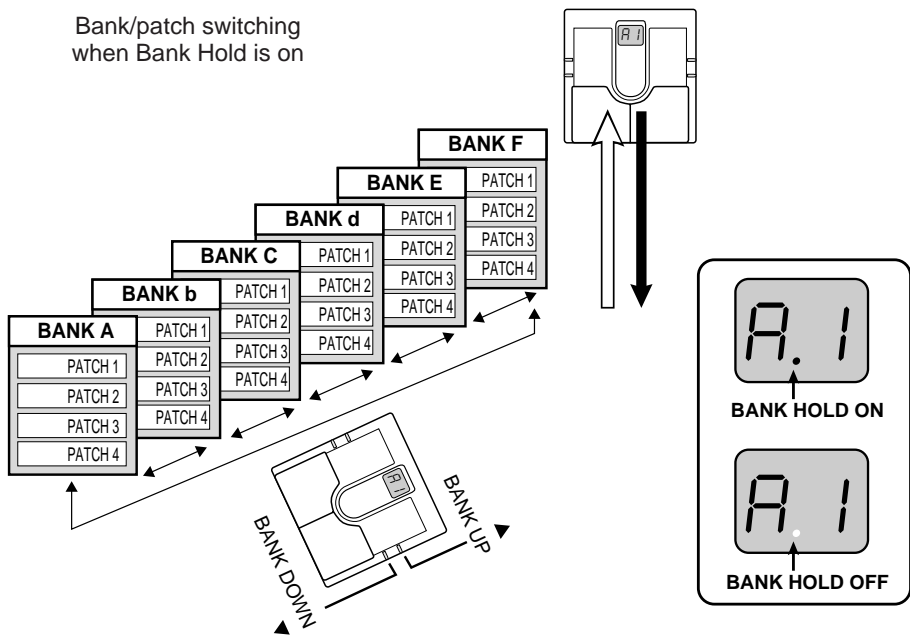

10 Patch Switching (Application: Direct Load OFF)

In the default condition, the 503 is set up in such a way that pressing a patch pedal immediately switches the patch and alters the output sound. This is called Direct Load ON. This switching principle is most convenient when the desired patches are adjacent or close to each other. However, when wanting to switch to a patch that is further away, it may be desirable not to activate the sound of the other patches in between.

When this is desired, turn the Direct Load function off as follows. When Direct Load has been turned off, switching banks and patches has no effect until the user confirms the selection.

For example, when going from patch 1 to patch 4 with Direct Load active, patches 2 and 3 will briefly be heard when the patch UP pedal is pressed three times. When Direct Load is off, pressing the patch UP pedal will change the number on the display (the number flashes), but until the user confirms the choice, the sound remains that of patch 1.

To turn Direct Load on or off, keep the STORE key depressed for at least 1 second. To confirm a choice after selecting a patch with Direct Load off, press both patch pedals simultaneously.

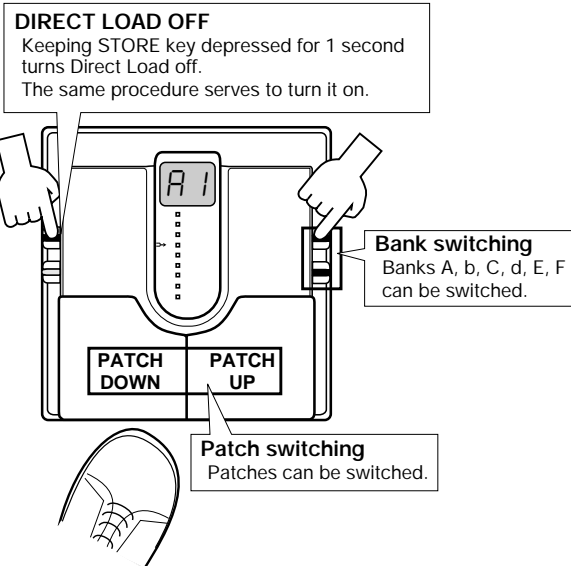

Confirming a patch
When display indication flashes, pressing both patch pedals together confirms the patch and switches the output sound.

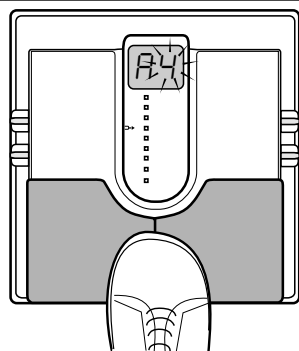

Press both pedals together

Example: Switching from patch 1 to patch 4

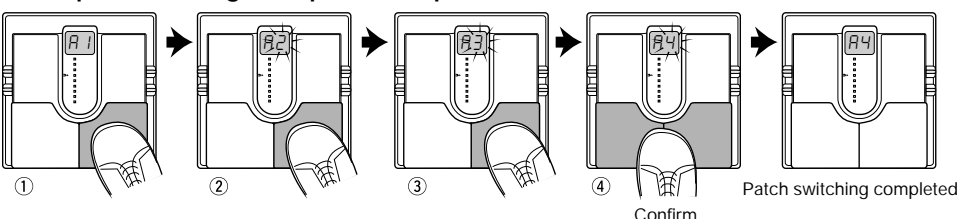

11 Editing Patches

The 503 comes with 24 predefined patches. But the unit offers many more possibilities for combining effects in innovative ways. To discover these possibilities, we recommend that you try changing the parameters (elements that make up patches) to create your own patches. This operation is called editing, and is done in the Edit mode.

To switch from normal Play mode to Edit mode, press the EDIT key briefly (for less than 1 second).

** Note that if the EDIT key is held down for 1 second or longer, the Bank Hold mode will be activated.*

Immediately after switching from Play mode to Edit mode, the AMP TYPE parameter cursor is flashing, and the AMP TYPE setting is shown on the display. This indicates that the AMP TYPE parameter is currently selected for editing.

In Edit mode, the EDIT key or PATCH UP/DOWN pedals are used to select the parameter for editing. The 503 has the following parameters:

- **AMP TYPE** : Selects the simulated amp characteristics.
- **GAIN** : Adjusts the intensity of distortion and compressor/limiter effects.
- **TREBLE** : Adjusts the high-frequency range.
- **MIDDLE/ENHANCE** : Adjusts the middle frequency range or the enhancer effect.
- **BASS** : Adjusts the low-frequency range.
- **CABINET TYPE & DEPTH** : Adjusts the cabinet type and the depth of cabinet ringing.
- **MIC POSITION & ZNR** : Adjusts the simulated mike position and the ZNR (Zoom Noise Reduction) sensitivity.
- **CHORUS/EFFECTS** : Selects the chorus, flanger, tremolo, doubling, and delay effects.

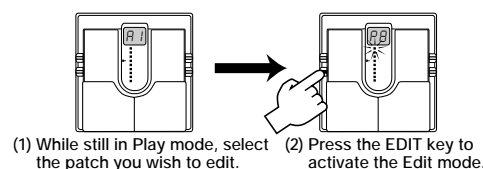

- **REVERB** : Selects the reverb and delay effects.
- **LEVEL** : Adjusts the overall level of the patch.

Each push of the EDIT key moves the blinking parameter cursor indicator one step down. The TUNER indicator serves as parameter cursor for the REVERB parameter, and the center dot (.) in the display for the LEVEL parameter. When the EDIT key or PATCH DOWN pedal is pressed while the lowest indicator (CHORUS/EFFECTS) is flashing, the TUNER indicator starts flashing and the REVERB parameter can be adjusted. When the EDIT key or PATCH DOWN pedal is further pressed, the center dot (.) in the display starts flashing and the LEVEL parameter can be adjusted.

The parameter value is changed using the VALUE +/- keys. For details on parameters, please refer to section "12. Effect Parameters".

To terminate the Edit mode and return to the Play mode, press the EDIT key while the LEVEL parameter is selected (center dot in the display is flashing). For information on how to store changed parameters, please refer to section "13. Storing Patches".

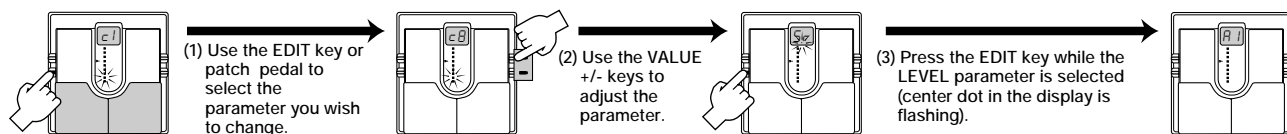

When the PATCH DOWN pedal is pressed while the center dot in the display is flashing, the AMP TYPE parameter is selected again and the unit stays in Edit mode.

12 Effect Parameters

PARAMETER 1 : AMP TYPE

Determines the simulated amplifier characteristics. Settings G1 - G9 are guitar amplifier settings. FL can be used both for guitar and bass amplifier simulation. b1 - b5 are bass amplifier settings.

Pressing either the VALUE + or - key switches to the next higher or lower setting.

Pressing both VALUE +/- keys together skips to settings in the following sequence: G1 - G9 -> FL -> b1.

PARAMETER 2 : GAIN

Adjusts the intensity of distortion, compressor, or limiter, according to the AMP TYPE selection.

Pressing the VALUE + or - key changes the setting by 1.

Pressing both VALUE +/- keys together skips as follows: 1 - 9 -> 10, 10 - 19 -> 20 - 29 -> 30

PARAMETER 3 : TREBLE

Adjusts the high-frequency sound character.

Pressing the VALUE + or - key changes the setting by 1.

Pressing both VALUE +/- keys together skips as follows: -10 - -1 -> 0, 0 - 9 -> 10

PARAMETER 4 : MIDDLE/ENHANCER

Adjusts the mid-frequency sound character or the enhancer effect.

Pressing the VALUE + or - key changes the setting by 1.

Pressing both VALUE +/- keys together skips as follows: -10 - -1 -> 0, 0 - 9 -> 10, 10 -> E1, E1 - E8 -> E9

PARAMETER 5 : BASS

Adjusts the low-frequency sound character.

Pressing the VALUE + or - key changes the setting by 1.

Pressing both VALUE +/- keys together skips as follows: -10 - -1 -> 0, 0 - 9 -> 10

G1 MS CRUNCH Simulates the crunch sound of a tube stack amp in the British style.	FL FLAT Flat setting in which only the amp simulator equalizer is used. Suitable both for guitar and bass.
G2 MS DRIVE Simulates the drive sound of a tube stack amp in the British style.	b1 TE CLEAN Clean sound with striking midrange.
G3 F CLEAN Simulates the clean sound of a built-in type tube amp.	b2 F DRIVE Vintage type drive sound.
G4 F DRIVE Simulates the drive sound of a built-in type tube amp.	b3 SW CLEAN Modern hi-fi type clean sound.
G5 BG DRIVE Simulates the drive sound of a tube combo amp with prominent midrange.	b4 AC DRIVE Drive sound with prominent mid and upper range.
G6 PV DRIVE Simulates the drive sound of a high-gain tube stack amp, ideal for heavy metal.	b5 CLEAN Clean line sound for bass.
G7 J CLEAN Simulates a clean sounding combo amp, good for chorus effects.	
G8 VX CRUNCH Simulates the drive sound of a tube combo amp, well suited to blues numbers.	
G9 CLEAN Clean line sound for guitar.	

1-30 Adjusts the distortion intensity when AMP TYPE is set to G1, G2, G4, G5, G6, or G8. Adjusts the compressor intensity when AMP TYPE is set to G3, G7, or G9. Higher values mean higher effect intensity. At a setting of "1", the effect is disabled.

-10 0 10 Negative values cause a treble cut and positive values a treble boost.

-10 0 10 Negative values cause a midrange cut and positive values a midrange boost.

E1-E9 Determine the frequency for the enhancer effect which emphasizes a certain frequency range only.

-10 0 10 Negative values cause a bass cut and positive values a bass boost.

1-30 Adjusts the limiter intensity when AMP TYPE is set to b1, b3, or b5. At a setting of "1", the effect is disabled.

1-30 Adjusts the distortion intensity when AMP TYPE is set to b2 or b4. Higher values mean stronger distortion.

-- Pressing the PATCH UP and DOWN pedals together causes the display to show the "--" indication. The amp simulator module is now switched off. Pressing the PATCH UP and DOWN pedals together once more turns the module back on again.

of Pressing the PATCH UP and DOWN pedals together causes the display to show the "of" indication. The Cabinet Simulator & ZNR module is now switched off. Pressing the PATCH UP and DOWN pedals together once more turns the module back on again.

0-9 Pressing the PATCH UP and DOWN pedals together causes the display to show "0" to "9". The cabinet simulator is now switched off. Pressing the PATCH UP and DOWN pedals together once more turns the module back on again.

PARAMETER 6 : CABINET TYPE & DEPTH

This parameter adjusts both the cabinet simulator type and the ringing depth.

Pressing the VALUE + or - key changes the setting by 1.

Pressing both VALUE +/- keys together skips as follows: c1 - c9 -> C1, C1 - C9 -> S1

PARAMETER 7 : MIC POSITION & ZNR

Controls the position of the simulated microphone before the cabinet and the ZNR (Zoom Noise Reduction) settings.

Pressing the VALUE + or - key changes the setting by 1.

Pressing both VALUE +/- keys together skips as follows: n0 - n9 -> S0, S0 - S9 -> F0

The letter at the left of the display indicates the cabinet type, and the number at the right the cabinet ringing depth. The higher the number, the stronger the ringing.

c1-c9 COMBO 1 Simulates a combo type guitar amp cabinet with one 12-inch speaker.	S1-S9 STACK Simulates a stack type guitar amp cabinet with four 10-inch speakers.
C1-C9 COMBO 2 Simulates a combo type guitar amp cabinet with two 12-inch speakers.	L1-L9 WALL Simulates a stack of ten guitar amp cabinets with 10-inch speakers.

The letter at the left of the display indicates the simulated mike position, and the number at the right the ZNR sensitivity. The higher the number, the more thoroughly will the noise in breaks during play be suppressed. Set the value as high as possible without causing the sound to become unnatural.

F9 MIC POSITION ↑ ZNR

When the MIC POSITION & ZNR setting of parameter 7 is 0 - 9, the CABINET TYPE & DEPTH parameter has no effect.

b1-b9 COMBO Simulates a bass amp cabinet with one 15-inch speaker.	B1-B9 STACK Simulates a bass amp cabinet with four 6.5-inch speakers.
---	--

S0-S9 Simulates sound as picked up by a microphone placed at an angle to the cabinet.

F0-F9 Simulates sound as picked up by a microphone placed at a distance from the cabinet.

* At the n0, S0, F0, and 0 settings, ZNR is off.

of Pressing the PATCH UP and DOWN pedals together causes the display to show the "of" indication. The Cabinet Simulator & ZNR module is now switched off. Pressing the PATCH UP and DOWN pedals together once more turns the module back on again.

PARAMETER 8 : CHORUS/EFFECTS

Selects modulation and spatial effects including chorus, flanger, and delay.

Pressing the VALUE + or - key changes the setting by 1.

Pressing both VALUE +/- keys together skips as follows: c1 - c9 -> C1, C1 - C9 -> F1

The letter at the left of the display indicates the effect, and the number at the right the effect intensity.

c1-c9 Mono chorus effect. Higher values result in a stronger chorus effect.	F1-F9 Flanger effect. Higher values result in faster modulation speed.	d1-d9 Doubling effect. Higher values result in longer delay time for the short delay.
C1-C9 Stereo chorus effect. Higher values result in a stronger chorus effect.	t1-t9 Tremolo effect. Higher values result in faster tremolo.	L1-L9 Long delay effect. Higher values result in longer delay time.

of Pressing the PATCH UP and DOWN pedals together causes the display to show the "of" indication. The Chorus/Effects module is now switched off. Pressing the PATCH UP and DOWN pedals together once more turns the module back on again.

of Pressing the PATCH UP and DOWN pedals together causes the display to show the "of" indication. The REVERB module is now switched off. Pressing the PATCH UP and DOWN pedals together once more turns the module back on again.

PARAMETER 9 : REVERB

Selects echo effects including reverb and long delay.

Pressing the VALUE + or - key changes the setting by 1.

Pressing both VALUE +/- keys together skips as follows: H1 - H9 -> r1, r1 - r9 -> S1

The letter at the left of the display indicates the effect, and the number at the right the effect intensity.

H1-H9 Hall reverb effect. Higher values result in a stronger hall reverb.	S1-S9 Spring reverb effect. Higher values result in a stronger string reverb.
r1-r9 Room reverb effect. Higher values result in a stronger room reverb.	L1-L9 Long delay effect. Higher values result in longer delay time.

of Pressing the PATCH UP and DOWN pedals together causes the display to show the "of" indication. The REVERB module is now switched off. Pressing the PATCH UP and DOWN pedals together once more turns the module back on again.

of Pressing the PATCH UP and DOWN pedals together causes the display to show the "of" indication. The REVERB module is now switched off. Pressing the PATCH UP and DOWN pedals together once more turns the module back on again.

PARAMETER 10 : LEVEL

Adjusts the overall level of the patch.

Pressing the VALUE + or - key changes the setting by 1.

Pressing both VALUE +/- keys together skips as follows: 1 - 9 -> 10, 10 - 19 -> 20

1-30 The higher the value, the higher the volume level of the patch.

of Pressing the PATCH UP and DOWN pedals together causes the display to show the "of" indication. The REVERB module is now switched off. Pressing the PATCH UP and DOWN pedals together once more turns the module back on again.

of Pressing the PATCH UP and DOWN pedals together causes the display to show the "of" indication. The REVERB module is now switched off. Pressing the PATCH UP and DOWN pedals together once more turns the module back on again.

HINT 1 Selection of parameters to change

As described in 11. Editing Patches, parameters to be edited are selected by repeatedly pressing the EDIT key, but you can also use the patch pedals for this purpose.

Press the PATCH UP pedal (right patch pedal) to move the parameter cursor from the bottom up.

Press the PATCH DOWN pedal (left patch pedal) to move the parameter cursor from the top down.

HINT 2 Switching modules on and off

When a parameter included in the Amp Simulator, Cabinet Simulator & MIC/ZNR, or Chorus/Effects module is selected, pressing the PATCH UP/DOWN pedals simultaneously will turn that module on or off. The on/off condition can also be stored as part of the patch.

- **To switch the amp simulator on or off**
In Edit mode, when any of the parameters AMP TYPE, GAIN, TREBLE, MIDDLE/ENHANCE, or BASS is selected, pressing the PATCH UP/DOWN pedals simultaneously turns the Amp Simulator module off. The indication "of" appears on the left side of the display, and "--" on the right.
- **To switch the Cabinet Simulator & ZNR module on or off**
In Edit mode, when any parameter of CABINET TYPE & DEPTH or MIC POSITION & ZNR is selected, pressing the PATCH UP/DOWN pedals simultaneously turns the module off (ZNR remains unaffected). For CABINET TYPE & DEPTH, the indication "of" appears on the display. For MIC POSITION & ZNR, "0" to "9" (ZNR setting only) is shown on the display.
- **To switch the Chorus/Effects module on or off**
In Edit mode, when the parameter CHORUS or EFFECTS is selected,

pressing the PATCH UP/DOWN pedals simultaneously turns the Chorus/Effects module off. The indication "of" appears on the display.

- **To switch the reverb module on or off**
In Edit mode, when the REVERB parameter is selected, pressing the PATCH UP/DOWN pedals simultaneously turns the Reverb module off. The indication "of" appears on the display.

* To turn any of the above modules on again, press the PATCH UP and DOWN pedals together once more, or press one of the VALUE +/- keys. The parameters return to their original setting.

HINT 3 Parameter setting shortcuts

Normally, parameter values are set by tapping the VALUE + or VALUE - key once for each increment or decrement. For quick operation, you can use the shortcut function. This is activated in the Edit mode by pressing both

HINT 4 Master level adjustment

With the 503 you are also able to set the master level that governs the overall output level. The master level is adjusted in Play mode. Hold the VALUE +/- keys down simultaneously for at least 1 second. The current master level will be displayed for 1 second. While the level is being displayed, use the VALUE +/- keys to change it. The setting range is 0-50. (Default value = 40) The unit does not store the setting for the master level. Each time the power is turned on it has to be set again.

13 Storing Patches

If you have edited (altered) a patch and turn the 503 off without storing the patch, the patch will revert to its old setting. To store an edited patch, use the following simple procedure.

Storing can be carried out in both Play mode and Edit mode. After you have edited the patch, press the STORE key. If the unit is currently in Play mode, release the key before 1 second has elapsed, otherwise the Direct Load function will be activated. The display starts to flash. This condition is called the store standby condition. If you wish, you can abandon the store procedure at this point by pressing the EDIT key. If you press the STORE key once more, the contents of the patch are updated. You can also change the patch number before storing, so that the edited patch will be stored in a different number. In this case, the original patch that was used as a starting point for editing will not be changed.

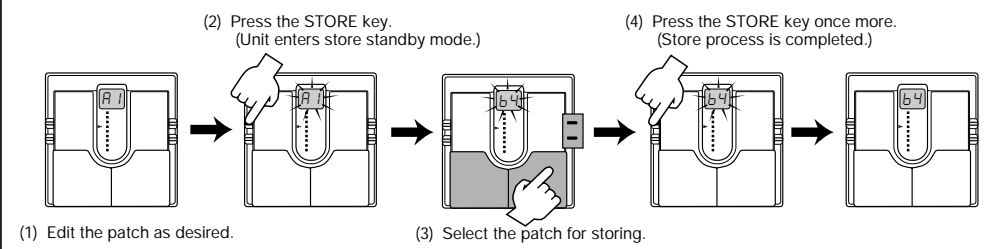

14 Replacing the Battery

If the tuning indicator flashes while the unit is being powered from the battery, the battery is exhausted and should be replaced as described below. Use only a 6LR61 9 V (alkaline) battery. Using another kind of battery will result in shorter operation.

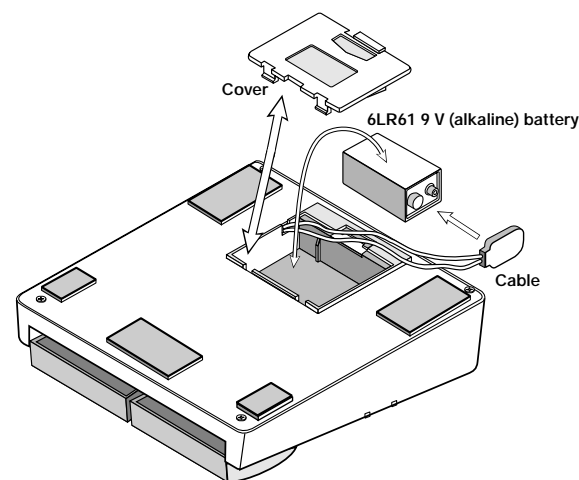

1. Turn the 503 upside down and open the cover of the battery compartment. (Push the catch to unlock the cover, then lift it up.)
2. Remove the battery from the compartment and disconnect the battery cable. (Grasp the terminal strip and do not pull at the cable.)
3. Connect the battery cable to the new battery, taking care to observe correct polarity (+/-). Then insert the battery into the battery compartment.
4. Close the battery compartment cover, taking care not to pinch the cable. (Make sure that the cover is properly locked.)

15 Returning Patches to Factory Settings

The 503 comes with 24 predefined patches that have been programmed at the factory. Also after you have edited and stored your own patches, you can return to the factory default settings at any time. This process is called "recalling". Returning all 24 patches to the original contents and resetting the Bank Hold and Direct Load functions is called "all initialize".

The Recall mode is separate from the Play mode and Edit mode. You cannot switch directly to Recall mode from these modes. The Recall mode can only be activated by turning the unit on in a special way, as described below.

1. Turn the unit off by disconnecting the AC adapter or the guitar input cable.
2. Keep the STORE key depressed and turn the unit on.
3. The indication "AL" flashes on the display.
4. To perform "all initialize", press the STORE key once more in this condition. The flashing rate increases and the initialization procedure is carried out. When it is completed, the unit automatically enters the Play mode.
5. When wishing to recall only a particular patch, select the patch number in step 3, using the same procedure as for normal patch selection.
6. When the desired patch has been selected, press the STORE key. The flashing rate increases and the contents of the selected patch are recalled.
7. Recalling of individual patches can be carried out continuously. When you wish to terminate the process, press the EDIT key. The unit then returns to the Play mode. Turning the unit off also terminates the recall condition.

16 Specifications

Effects:	32 effects AMP TYPE GUITAR AMP MS CRUNCH, MS DRIVE, F CLEAN, F DRIVE, BG DRIVE, PV DRIVE, J CLEAN, VX CRUNCH, CLEAN, FLAT BASS AMP TE CLEAN, F DRIVE, SW CLEAN, AC DRIVE, CLEAN CABINET TYPE GUITAR CABINET COMBO1, COMBO2, STACK, WALL BASS CABINET COMBO, STACK ZNR (ZOOM NOISE REDUCTION) CHORUS/EFFECTS Chorus, Stereo Chorus, Flanger, Tremolo, Doubling, Long Delay REVERB Hall, Room, Spring, Long Delay Maximum simultaneous effects: 5
Banks and Patches:	6 banks X 4 patches = 24 patches (edit + store possible)
Analog/Digital Conversion:	18 bit, 128 times oversampling
Digital/Analog Conversion:	16 bit, linear
Sampling Frequency:	31.25 kHz
Inputs:	HIGH input (standard monaural phone jack) Input impedance: 470 kilohms Rated input level: Electric Guitars and Basses with single-coil pick ups LOW input (standard monaural phone jack) Input impedance: 470 kilohms Rated input level: Electric Guitars and Basses with hum-bucking typ active type
AUX Input:	Mini phone jack/stereo Input impedance: 10 kilohms
Output:	Combined line/headphone output(stander stereo phone jack) Max. output level: +6 dBm Output load impedance: 10 kilohms or more
Display:	2-digit, 7-segment LED, tuning indicator, parameter cursor indicator
Power Requirements:	Optional AC adapter 9 VDC .300mA (ZOOM AD-0006)
Battery:	6LR61 9V (alkaline) battery X 1
Battery life:	Approx. 4h continuous operation
Dimensions:	147(W) X 157(D) X 49(H) mm
Weight:	480 g (without batteries)

* 0 dBm = 0.775 Vrms

* Design and specifications subject to change without notice.