



Technics

D	I	G	I	T	A	L
P	I	A	N	O		

SX-PX111





	CAUTION RISK OF ELECTRIC SHOCK DO NOT OPEN	
<p>CAUTION: TO REDUCE THE RISK OF ELECTRIC SHOCK, DO NOT REMOVE SCREWS. NO USER-SERVICEABLE PARTS INSIDE. REFER SERVICING TO QUALIFIED SERVICE PERSONNEL.</p>		

 The lightning flash with arrowhead symbol, within an equilateral triangle, is intended to alert the user to the presence of uninsulated "dangerous voltage" within the product's enclosure that may be of sufficient magnitude to constitute a risk of electric shock to persons.

 The exclamation point within an equilateral triangle is intended to alert the user to the presence of important operating and maintenance (servicing) instructions in the literature accompanying the appliance.

FOR YOUR SAFETY PLEASE READ THE FOLLOWING TEXT CAREFULLY. (for UNITED KINGDOM)

This appliance is supplied with a moulded three-pin mains plug for your safety and convenience. A 5 amp fuse is fitted in this plug. Should the fuse need to be replaced please ensure that the replacement fuse has a rating of 5 amps and that it is approved by ASTA or BSI to BS1362. Check for the ASTA mark  or the BSI mark  on the body of the fuse.

If the plug contains a removable fuse cover you must ensure that it is refitted when the fuse is replaced. If you lose the fuse cover the plug must not be used until a replacement cover is obtained. A replacement fuse cover can be purchased from your local Panasonic/Technics Dealer.

IF THE FITTED MOULDED PLUG IS UNSUITABLE FOR THE SOCKET OUTLET IN YOUR HOME THEN THE FUSE SHOULD BE REMOVED AND THE PLUG CUT OFF AND DISPOSED OF SAFELY. THERE IS A DANGER OF SEVERE ELECTRICAL SHOCK IF THE CUT-OFF PLUG IS INSERTED INTO ANY 13 AMP SOCKET.

If a new plug is to be fitted please observe the wiring code as shown below. If in any doubt please consult a qualified electrician.

IMPORTANT: —The wires in this mains lead are coloured in accordance with the following code:—

Blue:	Neutral
Brown:	Live

As the colours of the wires in the mains lead of this appliance may not correspond with the coloured markings identifying the terminals in your plug, proceed as follows.

The wire which is coloured BLUE must be connected to the terminal in the plug which is marked with the letter N or coloured BLACK.

The wire which is coloured BROWN must be connected to the terminal in the plug which is marked with the letter L or coloured RED.

Under no circumstances should either of these wires be connected to the earth terminal of the three-pin plug, marked with the letter E or the Earth Symbol .

How to replace the fuse. Open the fuse compartment with a screwdriver and replace the fuse and fuse cover.

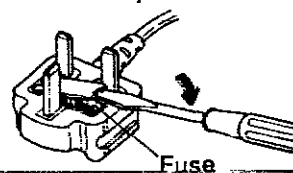

Technics

**OWNER'S MANUAL
MODE D'EMPLOI
INSTRUCCIONES DE MANEJO**

**GEBRUIKSAANWIJZING
ISTRUZIONI PER L'USO
使用説明書**

Caution

Voltage (except North America, Mexico, New Zealand and Europe excluding United Kingdom)
Be sure the voltage adjuster located on the back of piano is in accordance with local voltage in your area before using this unit. Use a screwdriver to set the voltage adjuster to the local voltage.

Before you play, please read the cautionary copy appearing on page 19.

Attention

Tension (à l'exception de l'Amérique du nord, du Mexique, de la Nouvelle-Zélande et de l'Europe excepté l'Angleterre)
Avant de mettre cet appareil sous tension s'assurer que le sélecteur de tension situé sur le dos du piano est réglé sur la tension locale. Pour régler le sélecteur de tension utiliser un tournevis.

Avant toute utilisation, prière de lire l'avertissement apparaissant à la page 37.

Precaución

Tensión (excepto América del Norte, México, Nueva Zelanda y Europa excluyendo el Reino Unido)
Cerciórese de que el ajustador de tensión, situado en la parte posterior del piano, esté ajustado al valor de la tensión de su residencia. Efectúe esta comprobación antes de utilizar el instrumento. Para ajustar la tensión emplee un destornillador para posicionar el ajustador de tensión al valor correspondiente.

Antes de empezar a tocar, lea las precauciones de la página 55.

Attentie

Netspanning (behalve voor Noord Amerika, Mexico, Nieuw-Zeeland en Europa uitgezonderd Groot-Brittannië)

Let er op dat de spanningscaroussel, die zich op de achterkant van de piano bevindt, op de juiste netspanning staat vóór het instrument wordt aangesloten: Gebruik een kleine schroevendraaier om de spanningscaroussel in te stellen.

Voordat u gaat spelen, lees de waarschuwingpunten op bladzijde 73 zorgvuldigheid en goed door.

Attenzione

Voltaggio (eccetto Nord America, Messico, Nuova Zelanda ed Europa escluso il Regno Unito)

Assicurarsi che il cambio tensione, sulla parte posteriore del pianoforte, concordi la tensione con il voltaggio della tensione di rete. Usate nel caso un cacciavite per adattare la tensione.

Prima di suonare vi consigliamo di leggere le indicazioni della pagina 91.

注意事項

電壓(不包括北美洲、墨西哥、新西蘭及英國除外的歐洲)

當使用之前，應確認調壓器(設於鋼琴背部)的數值是否符合該地區的電壓。如不符合時，要用螺絲刀來旋轉調壓按鈕，對合到所用電壓位置，才可使用。

用本琴演奏之前，請仔細閱讀第109頁注意事項，以便正確使用。

Contents

Getting started	3
Listen to the demonstration	4
Sounds and effects	6
Mixing two sounds	8
• Mixing sounds	8
• Volume balance	8
Transpose	9
Tuning	9
Sequencer	10
• How to use the sequencer	10
• Recording	10
• Playback	12
• Erasing a track	12
Setting the functions	13
• Settings which can be adjusted	13
• Procedure	13
MIDI	14
• About the MIDI terminals	14
• Connection examples	14
• The following kinds of data can be transmitted/received	15
• Assigning the MIDI CHANNEL (MIDI CH)	15
• The following MIDI functions can be set	16
• Procedure	16
• Transmitting PROGRAM CHANGE numbers	17
Connections	18
Symptoms which appear to be signs of trouble	18
Caution for safest use of this unit	19
Assembly	110
MIDI Implementation Chart	111
Specifications	112

Getting started

1 Plug the power cord into an outlet.

2 Press the **POWER** button to turn it on.

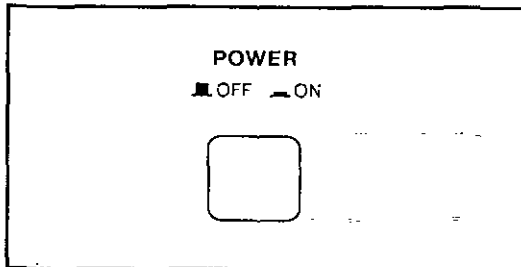

3 Play the keyboard.
• Set the **MAIN VOLUME** to an appropriate level with the sliding control.

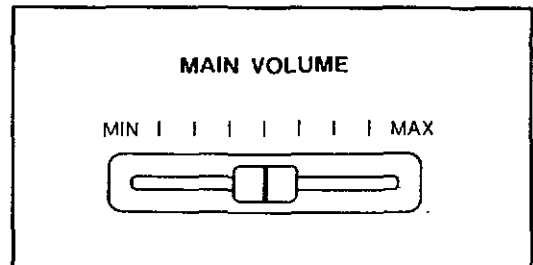

• No sound will be heard when the sliding control is set to **MIN**.

Tuning

Unlike an acoustic piano, your Digital Piano never needs tuning.

• The pitch of this instrument can be adjusted when playing along with other instruments. (Refer to page 9.)

Music stand

Insert the music stand in the two holes as shown in the figure.

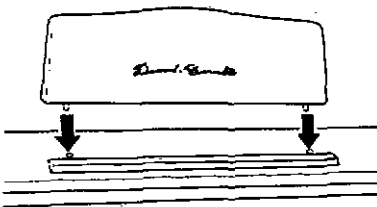

Listen to the demonstration

Automatic performances which introduce you to the sounds are stored in the memory of this piano.

Grand piano demonstration performance (5 tunes)

1 Press the **DEMO** button.

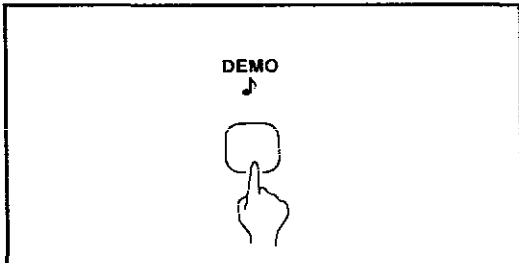

- The indicators for the **SOUND** buttons flash.

2 Select **GRAND PIANO**.

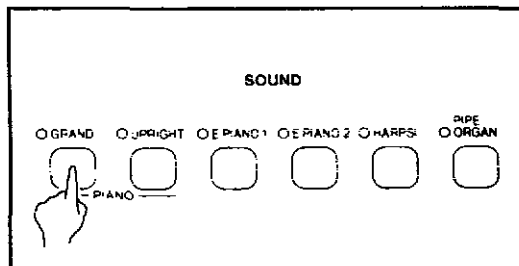

- The **SOUND** buttons which contain **GRAND PIANO** demonstration tunes are shown by the flashing indicators.

3 Select a **SOUND** button (other than **GRAND PIANO**) whose indicator is flashing.

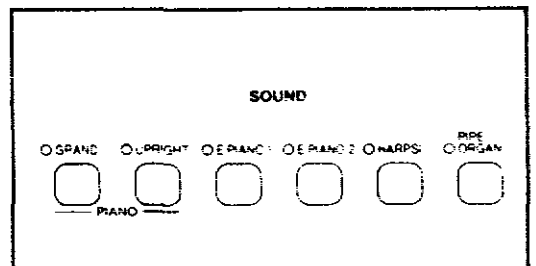

- The demonstration tune starts.
- The indicator of the selected **SOUND** button flashes.
- If the button for the current demonstration tune is pressed, the demonstration performance stops.
- Listen to the other **GRAND PIANO** demonstration tunes in the same way.

4 When you are finished listening to the demonstration tunes, press the **DEMO** button again.

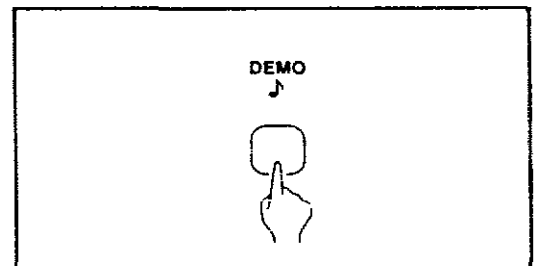

GRAND PIANO demonstration tunes

No.	Composer	Title
1	CHOPIN	SONATE III MOV.1
2	CHOPIN	GRANDE VALSE BRILLANTE A ⁺ MAJOR Opus 34 No.1
3	LISZT	LOVE'S DREAM No.3
4	Technics original	—
5	Technics original	—

- The flashing **SOUND** indicators, from left to right, correspond to tunes 1 to 5.

Demonstration performances for other sounds (5 tunes)

1 Press the **DEMO** button.

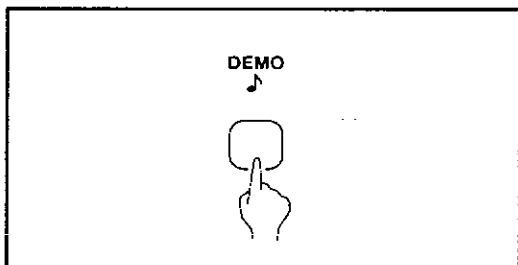

- The indicators for the **SOUND** buttons flash.

2 Select a sound (other than **GRAND PIANO**) you wish to hear.

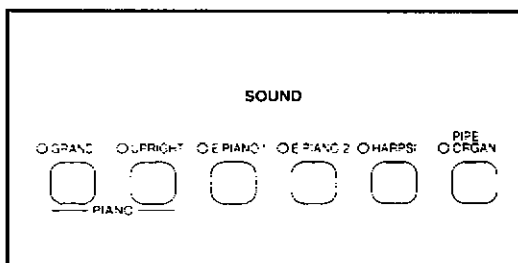

- The demonstration tune starts.
- The indicator of the selected **SOUND** button flashes and the other indicators go out.
- If the button for the current demo is pressed, the demonstration performance stops.
- Listen to the demonstration tunes for the other sounds in the same way.

3 When you have finished listening to the demonstration performances, press the **DEMO** button to turn it off.

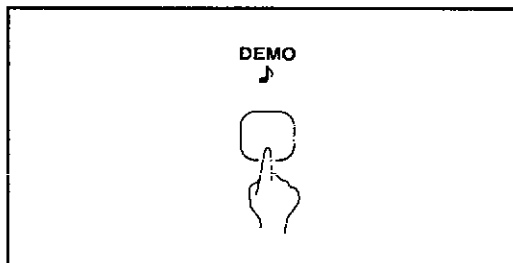

Listen to all the demonstration tunes in order.

Press and hold the **DEMO** button for a few seconds.

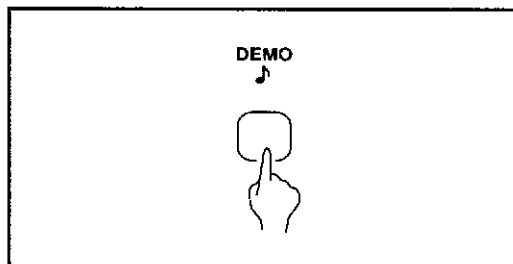

- All the demonstration tunes are automatically played in order.
- If you press the button with the flashing indicator during the demonstration performance, the current tune stops and the next tune begins.
- You can also first press the **DEMO** button and then the **START/STOP** button to play the tunes in order.
- The tunes are repeated in order until the **DEMO** button or **START/STOP** button is pressed again.

- You can play the keyboard while the demonstration performances are playing.
- The **UPRIGHT PIANO** demonstration performance is "FOR ELISE" (BEETHOVEN). The other demonstration performances are Technics original melodies.

Sounds and effects

SOUND

Press one of the **SOUND** buttons to select the desired sound.

Each sound features Touch Response, which increases the volume when the keyboard is played harder.

- The sounds can be mixed when two **SOUND** buttons are pressed simultaneously. (Refer to page 8.)
- On this piano, the maximum number of notes which can sound simultaneously is 32. (When two sounds are mixed, the number becomes half.)

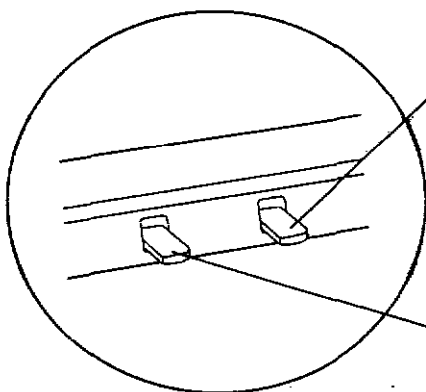
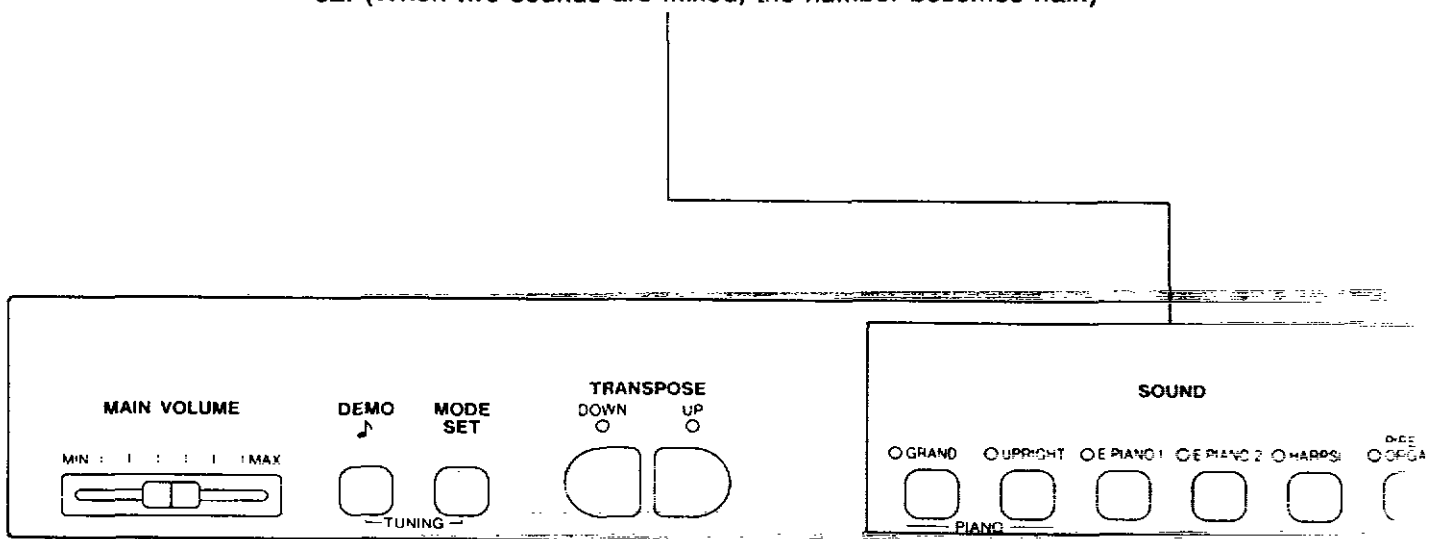

Sustain pedal

The right pedal allows you to use sustain. When a key is released while this pedal is depressed, the sound is sustained so that it lingers and slowly fades out.

- For the **GRAND PIANO** and **UPRIGHT PIANO** sounds, the tones of the 17 uppermost keys are automatically sustained just like in an acoustic piano.

Soft pedal

The left pedal can be used as a soft pedal. When the pedal is depressed, the sound is softer.

- The soft pedal can also be used as a sostenuto pedal. (Refer to page 13.)

DIGITAL REVERB

DIGITAL REVERB applies a reverberation effect to the sound. Select from three echo types—**ROOM**, **STAGE** and **HALL**.

TOUCH SENSITIVITY

The keyboard touch (Touch Response) can be changed to match your type of playing.

- Choose from **LIGHT**, **NORMAL** and **HEAVY**.

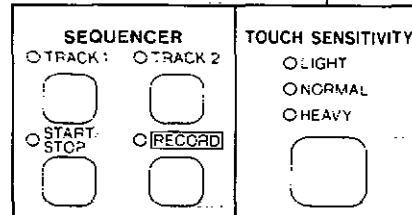
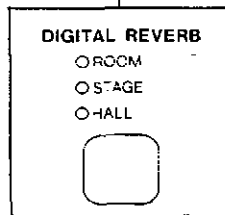
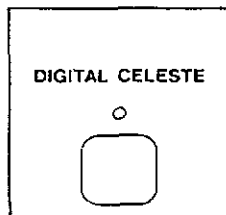

DIGITAL CELESTE

A celeste effect can be applied to give the sound greater depth.

SEQUENCER

Record your performance and have it automatically played back. (Refer to page 10.)

Setting the effects for each sound

The **DIGITAL CELESTE** and **DIGITAL REVERB** are stored independently for each sound. When a **SOUND** button is pressed, the effect settings for the selected sound are recalled.

Mixing two sounds

You can play two different sounds at the same time, thus obtaining a composite sound having a depth not possible in a single sound. The volume balance for each of the sounds can also be adjusted.

Mixing sounds

1. Press two **SOUND** buttons at the same time.

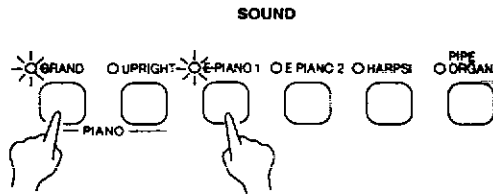

2. Press any key on the keyboard to hear the mixed sound.

- When sounds are mixed, the sustain pedal does not function for the **HARPSI** and **PIPE ORGAN** sounds.
- The volume balance and effects can be set and memorized for each combination of mixed sounds.

Volume balance

1. Press the two **SOUND** buttons continuously for 2 or 3 seconds.

- The indicators for the two sounds and the **TRANSCOPE** indicators flash.

2. Use the **TRANSCOPE** buttons to adjust the volume balance.

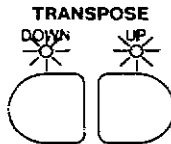

3. When you have finished adjusting the volume balance, press any **SOUND** button.

- Each time the **UP** button is pressed, the volume of the right-side sound increases, and each time the **DOWN** button is pressed, the volume of the left-side sound increases. Play the keyboard to hear the volume balance.
- If either sound is set to the maximum volume and you attempt to further increase its volume, the **TRANSCOPE** indicators flash.
- If the two buttons are pressed at the same time, the volume is equally balanced.

Transpose

Suppose you learn to play a song—in the key of C, for example—and decide you want to sing it, only to find it's either too high or too low for your voice. Your choice is to either learn the song all over again, in a different key, or to use the **TRANSPOSE** feature.

Use the **TRANSPOSE** buttons to adjust the key.

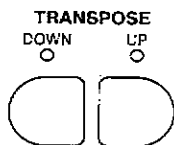

- If either of the **TRANSPOSE** indicators remains lit, it indicates that the piano is set to a key other than C.
- The indicators will flash if you attempt to transpose to a key higher or lower than the upper (F[♯]) or lower (G) limit.
- If the two buttons are pressed at the same time, the key returns to C.

Each press of the DOWN button:		Each press of the UP button:
G ← A [♭] ← A ← B [♭] ← B ←	C	→ D [♯] → D → E [♯] → E → F → F [♯]

Tuning

The pitch of the instrument can be adjusted. This capability is useful, for example, for ensemble playing.

1. Press the **DEMO** and **MODE SET** buttons simultaneously.

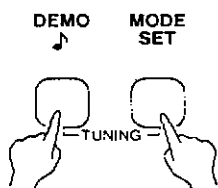

3. When you have finished adjusting the pitch, press either the **DEMO** button or the **MODE SET** button.

2. Use the **TRANSPOSE** buttons to adjust the pitch.

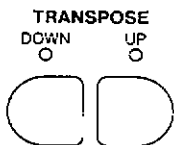

- Press the **UP** button to raise the pitch and press the **DOWN** button to lower the pitch (427.3–440.0–453.0 Hz).
- Press and hold either **TRANSPOSE** button to change the pitch quickly.
- The indicators will flash if you attempt to set the pitch higher or lower than the upper or lower limit.
- If both **TRANSPOSE** buttons are pressed at the same time, the pitch returns to 440.0 Hz.

Sequencer

You can store your performance in the **SEQUENCER** and have it played back. There are two **SEQUENCER** tracks, each of which can be recorded independently (multi-track recording) and played back separately or together.

How to use the sequencer

- Record your performance just as you play it.

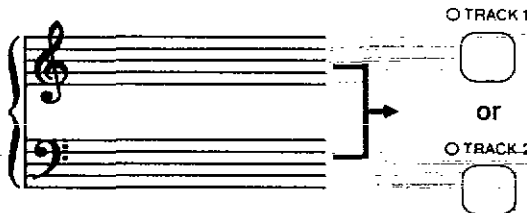

- Record each of the two parts separately (multi-track recording).

1. Record part 1 in **TRACK 1**.

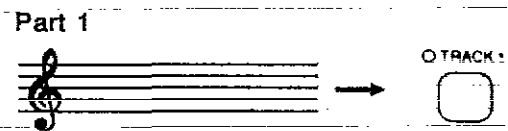

2. While playing back part 1, record part 2 in **TRACK 2**.

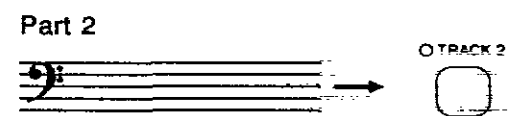

The performance data, pedal operation, beginning sound and sound selection changes and **DIGITAL CELESTE** on/off operation are all recorded in the **SEQUENCER**.

- Record, for example, the right-hand part in **TRACK 1** and left-hand part in **TRACK 2**.

Recording

Follow these step-by-step instructions to record the example below in the **SEQUENCER**.

< TRACK 1 >
GRAND PIANO

< TRACK 2 >
PIPE ORGAN

A musical score for two tracks. The top staff is labeled '< TRACK 1 > GRAND PIANO' and contains a treble clef staff with a melodic line. The bottom staff is labeled '< TRACK 2 > PIPE ORGAN' and contains a bass clef staff with a harmonic accompaniment. The two staves are bracketed together on the left.

A second musical score for two tracks, identical in notation to the one above, showing the Grand Piano and Pipe Organ parts.

■ **Record TRACK 1.**

1. Select the sound and set the **DIGITAL CELESTE** to on or off.

2. Press the **RECORD** button to turn it on.

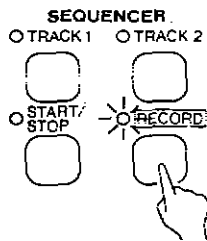

- The **TRACK 1** and **2** indicators flash rapidly.

3. Press the **TRACK 1** button.



- The **TRACK 2** indicator goes out and the **TRACK 1** indicator flashes slowly.

4. Play the **TRACK 1** part.



- Recording starts when you begin to play the keyboard.
- Recording will also begin if the **START/STOP** button is pressed.

5. When you have completed recording the **TRACK 1** part, press the **RECORD** button to turn it off.



- Recording will also stop if the **START/STOP** button is pressed.
- The indicator for the recorded track changes from flashing to the lit condition.

■ **Record TRACK 2.**

1. Select the sound and set the **DIGITAL CELESTE** to on or off.

2. Confirm that the **TRACK 1** indicator is lit.

- If it is not lit, press the **TRACK 1** button to turn it on.

3. Press the **RECORD** button to turn it on.

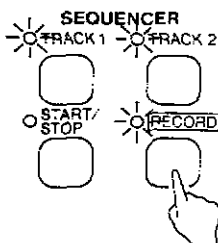

- The **TRACK 2** indicator flashes rapidly.

4. Press the **TRACK 2** button.

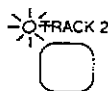

- The **TRACK 2** indicator flashes slowly.

5. Play the **TRACK 2** part.



- Because the part already recorded in **TRACK 1** is played back automatically, you can play the **TRACK 2** part in time with it.
- Recording will also begin if the **START/STOP** button is pressed.

6. When you have completed recording the **TRACK 2** part, press the **RECORD** button to turn it off.



■ More about SEQUENCER recording

- Expressed in terms of notes, the total number of notes which can be recorded in both SEQUENCER tracks is about 4000.
- When an error tone sounds, the memory is full and the recording mode stops automatically.
- You cannot record both tracks at the same time.
- If you record a track that has already been recorded, the previous recording will be erased.
- The recorded contents remain in the memory for about one week after the power to this instrument is turned off.

Playback

1. Confirm that the Indicators are lit for the tracks you wish to have played back.

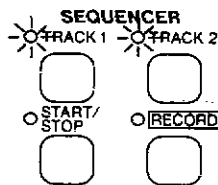

- Tracks whose indicators are not lit will not be played back.

2. Press the START/STOP button.



- The recorded tune is played back from the beginning.

Erasing a track

While pressing the MODE SET button, press the button for the track you wish to erase until a beep tone sounds (about 2 or 3 seconds).

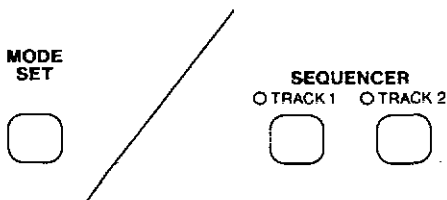

- You can erase both tracks at the same time by pressing the two track buttons simultaneously.
- You cannot erase a track by this method when the RECORD button is on.

The contents of the SEQUENCER remain in the memory for about one week after the POWER is turned off.

Setting the functions

You can set various functions, for example, the type of tuning, or how the sound is produced when the keys are pressed very slowly.

Settings which can be adjusted

Function	on (when indicator is lit)	off (when indicator is not lit)
PIANO TUNING	Standard acoustic piano tuning, in which the lower pitches are tuned slightly lower and the higher pitches are tuned slightly higher (default setting).	Standard equal temperament.
MINIMUM RANGE	No sound is produced when a key is played extremely softly (default setting). • For the HARPSI and PIPE ORGAN sounds, sound is always produced even when MINIMUM RANGE is set to on.	In piano-type sounds, sound is produced regardless of how softly the keys are pressed.
SOSTENUTO*	The soft pedal works as a sostenuto pedal. • For the PIPE ORGAN sound, the tones continue to sound for as long as the pedal is depressed.	The soft pedal works as a normal soft pedal (default setting).

* If the pedal is pressed while the keys are pressed, a sustain effect is applied to those notes only.

Procedure

While pressing the **MODE SET** button, turn the desired function on or off by pressing the relevant button.

- When changing the settings, the panel buttons function as shown in the illustrations.

■ Initialization

If the **INITIAL** key on the keyboard (see page 17) is pressed while the **MODE SET** button is depressed, all settings return to their default status.

- Note that when you perform the initialization procedure, the MIDI settings (refer to page 16) are also returned to their default status.

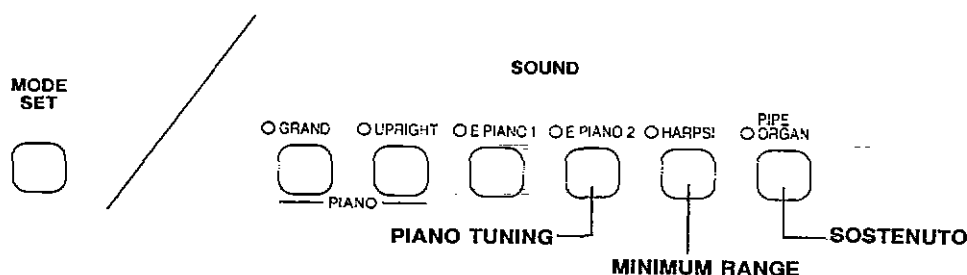

MIDI

MIDI (Musical Instrument Digital Interface) is the international standard for digital communication of electronic musical instrument data. This means that any equipment which has a MIDI terminal—such as electronic musical instruments and personal computers—can easily exchange digital data with other MIDI equipment without resorting to complicated conversions or connections.

About the MIDI terminals

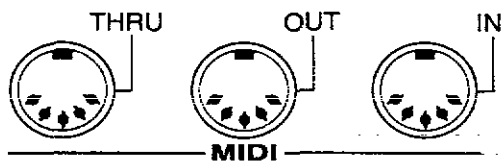

IN: The terminal by which this Instrument receives data from other equipment.

OUT: The terminal that transmits data from this instrument to other equipment.

THRU: The terminal that transfers data from the **IN** terminal directly to other equipment.

- For these connections, use a commercially available MIDI cable. Contact your Technics dealer for more information.

Connection examples

- To generate sound from a connected instrument by playing this instrument

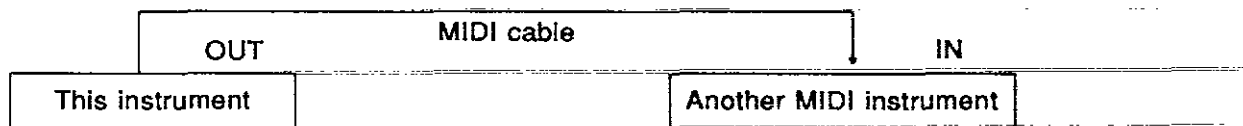

- To generate sound from this Instrument by operating a connected MIDI sequencer

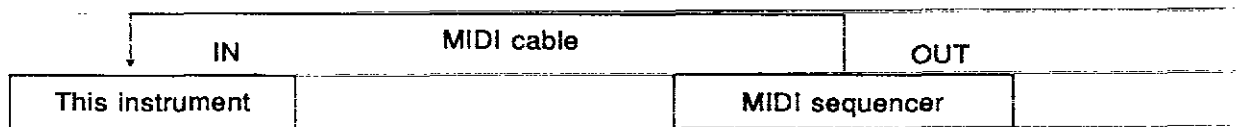

The following kinds of data can be transmitted/received.

- Key note on/off data (keyboard performance data)
- Pedal on/off data
- **DIGITAL CELESTE** on/off data
- **PROGRAM CHANGE** (sound selection change) data*

* Refer to page 17 regarding data transmission.

Assigning the MIDI CHANNEL (MIDI CH)

You can assign a MIDI CHANNEL number (1–16) to this instrument.

- The default channel setting is 1.

While pressing the **MODE SET** button, use the 16 lowermost keys (see illustration) to assign the desired MIDI CHANNEL number.

MODE
SET

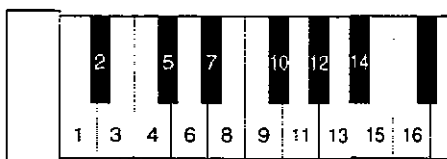

Keyboard and MIDI note number

8va bassa

Middle C

8va

MIDI note number

21 24 28 36 48 60 72 84 96 103 108

The following MIDI functions can be set.

The **TRANPOSE** buttons and some of the **SOUND** buttons, when used in conjunction with the **MODE SET** button, serve to set the following MIDI functions.

Function	on (when indicator is lit)	off (when indicator is not lit)
MULTI TIMBRE	This piano can be used as a multiple sound generator, and data can be received separately for each sound. •When set to on, the OMNI ON setting automatically turns off.	This piano cannot be used as a multiple sound generator (default status).
	•The MIDI channel for each sound is 1, 2, 3, etc. following the SOUND buttons as they are lined up from left to right.	
LOCAL CONTROL	The performance from this instrument also sounds from this instrument (default status). •When the POWER is turned on, the LOCAL CONTROL is set to on.	The performance from this instrument does not sound from this instrument. Set to off when this instrument is to be used only to transmit data to connected equipment.
OMNI ON	Data is received for all MIDI channels (default status). •When set to on, the MULTI TIMBRE setting automatically turns off.	Data is received only on MIDI channels which are matched. •For assigning this instrument's MIDI channels, refer to page 15.
PROGRAM CHANGE	PROGRAM CHANGE data is transmitted/received (default status). •You can also transmit data for any PROGRAM CHANGE number. (Refer to page 17.)	PROGRAM CHANGE data is not transmitted/received.
TRANPOSE	When this instrument's TRANPOSE function is active, note numbers of the transposed notes are transmitted.	When this instrument's TRANPOSE function is active, note numbers of the played keys (non-transposed notes) are transmitted (default status).

Procedure

While pressing the **MODE SET** button, turn the desired function on or off by pressing the relevant button.

- When using the MIDI functions, the panel buttons function as shown in the illustrations.

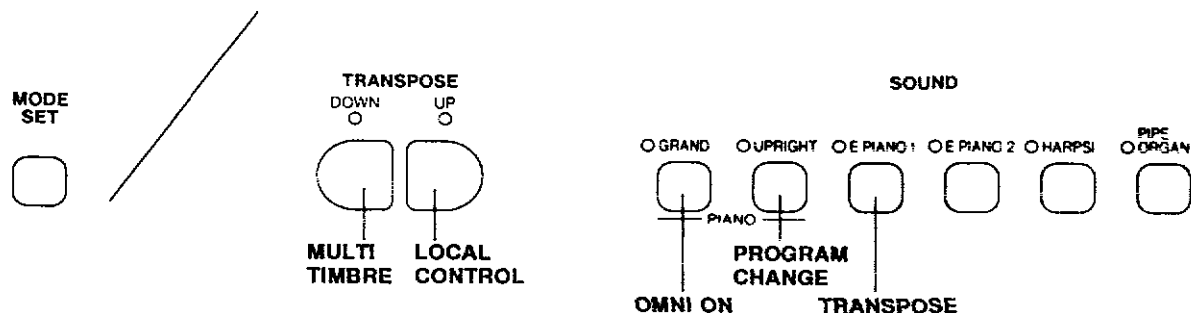

Transmitting PROGRAM CHANGE numbers

This piano can be used to transmit desired PROGRAM CHANGE numbers to the connected instrument.

While pressing the **MODE SET** button, using the numbers on the keyboard illustration below for reference, press a black key to specify the **BANK** and a white key to specify the **NUMBER**. (Refer to the PROGRAM CHANGE number table.)

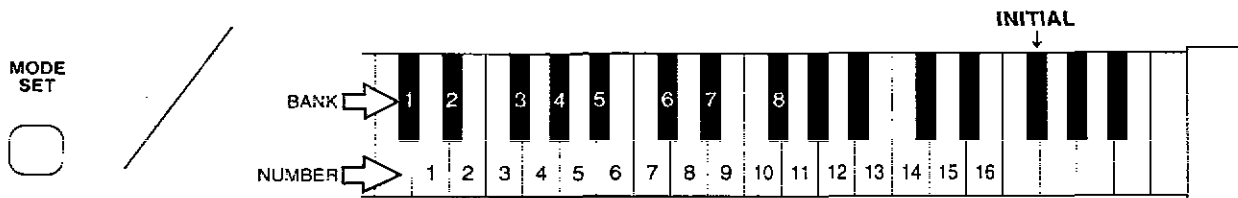

- PROGRAM CHANGE numbers are transmitted by combining a **BANK** and **NUMBER** to specify the desired PROGRAM CHANGE number 0-127.
- You can also use the **SOUND** buttons to specify the PROGRAM CHANGE number, beginning with 0 as they are lined up from left to right.

PROGRAM CHANGE number table

BANK \ NUMBER	1	2	3	4	5	6	7	8	9	10	11	12	13	14	15	16
1	0	1	2	3	4	5	6	7	8	9	10	11	12	13	14	15
2	16	17	18	19	20	21	22	23	24	25	26	27	28	29	30	31
3	32	33	34	35	36	37	38	39	40	41	42	43	44	45	46	47
4	48	49	50	51	52	53	54	55	56	57	58	59	60	61	62	63
5	64	65	66	67	68	69	70	71	72	73	74	75	76	77	78	79
6	80	81	82	83	84	85	86	87	88	89	90	91	92	93	94	95
7	96	97	98	99	100	101	102	103	104	105	106	107	108	109	110	111
8	112	113	114	115	116	117	118	119	120	121	122	123	124	125	126	127

■ Initialization

If the **INITIAL** key on the keyboard (see above) is pressed while the **MODE SET** button is depressed, all settings return to their default status.

- Note that when you perform the initialization procedure, the function settings (refer to page 13) are also returned to their default status.

While the **MODE SET** button is depressed, the keyboard keys do not produce sound.

Connections

(On the back of piano)

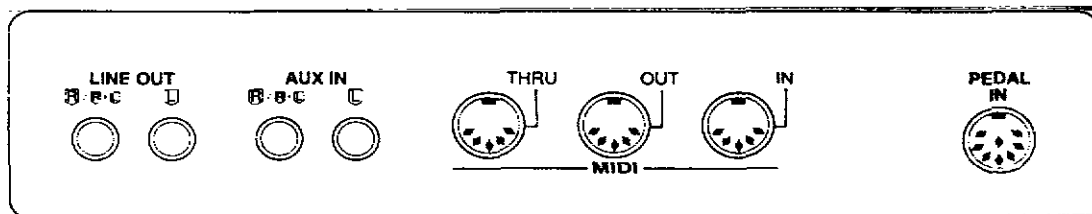

PEDAL IN

Connect the cord from the included stand to this terminal.

AUX IN (input level 0.5 Vrms, 6 kΩ)

Other instruments such as a rhythm machine or sound module can be connected to the piano so that the sound is output from the piano. To receive monaural sound, connect instruments to the R/R+L terminal.

LINE OUT (output level 1.5 Vrms, 600 Ω)

By plugging into a high-power amplifier, the sound can be reproduced at high volume. (Use the R/R+L terminal when outputting monaural sound.)

PHONES (Ω) x2

(Beneath the keyboard, on the left side)

For silent practice headphones may be used. When plugged in, the speaker system is automatically switched off, and sound is heard only through the headphones.

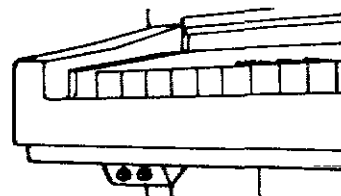

Symptoms which appear to be signs of trouble

Phenomenon	Remedy
No sound is produced when the keyboard is played.	<ul style="list-style-type: none"> No sound is produced if the MAIN VOLUME is set to MIN. Use the sliding control to set the volume to an appropriate level. If the MIDI LOCAL CONTROL is set to off, set it to on. (Refer to page 16.)

■ About the back-up memory

The selected sound and various functions, MIDI settings and **SEQUENCER** contents remain in the memory for about one week after the **POWER** is turned off. If you wish to return all memories and settings to their initialized status, while pressing the **MODE SET** button, press the

INITIAL key on the keyboard. Or you can turn on the **POWER** while pressing the **INITIAL** key.

- When the **POWER** is turned on, the **MIDI LOCAL CONTROL** is set to on.

Cautions for safest use of this unit

Installation location

1. A well-ventilated place.
Take care not to use this unit in a place where it will not receive sufficient ventilation, and not to permit the ventilation holes to be covered by curtains, or any similar materials.
2. Place away from direct sunlight and excessive heat from heating equipment.
3. A place where humidity, vibration and dust are minimized.

Power source

1. Be sure the line voltage selector is in accordance with local voltage in your area before connecting the plug to the socket.
2. DC power cannot be used.

Handling the power cord

1. Never touch the power cord, or its plug, with wet hands.
2. Don't pull the power cord.

Metal items inside the unit may result in electric shock or damage.

Do not permit metal articles to get inside the unit.

Be especially careful with regard to this point if children are near this unit. They should be warned never to try to put anything inside.

If, nevertheless, some such article does get inside, disconnect the power cord plug from the electrical outlet, and contact the store where the unit was purchased.

If water gets into the unit

Disconnect the power cord plug from the electrical outlet, and contact the store where it was purchased.

As a precaution, it is suggested that flower vases and other containers which hold liquids not be placed on the top of this unit.

If operation seems abnormal

Immediately turn off the power, disconnect the power cord plug from the electrical outlet, and contact the store where it was purchased.

Discontinue using the unit at once. Failure to do so may result in additional damage or some other unexpected damage or accident.

- Because the power source is located inside the unit, it is normal for the cabinet to become warm.

A word about the power cord

If the power cord is scarred, is partially cut or broken, or has a bad contact, it may cause a fire or serious electrical shock if used. NEVER use a damaged power cord for any appliance. Moreover, the power cord should never be forcibly bent.

Don't touch the inside parts of this unit.

Some places inside this unit have high voltage potential. Never try to remove the top or back panels of this unit, or to touch inside parts by hand or with tools.

Contact someone who is qualified in order to inspect the inside, or to replace a fuse, if such becomes necessary. Never attempt to do these things yourself.

Maintenance

The following suggestions will assist you in keeping the unit in top condition.

- Be sure to switch the instrument off after use, and do not switch the unit on and off in quick succession, as this places an undue load on the electronic components.
- To keep the luster of the surface and buttons, simply use a clean, damp cloth; polish with a soft, dry cloth. Polish may be used but do not use thinners or petro-chemical-based polishes.
- A wax-based polish may be used on the cabinet, although you will find that rubbing with a soft cloth will suffice.

**SERVICE MUST BE CARRIED OUT BY DEALER
OR OTHER QUALIFIED PERSON**

Table des matières

Note préliminaire	21
Ecoute de la démonstration	22
Sonorités et effets	24
Mélanger deux sonorités	26
• Mélanger deux sonorités	26
• Réglage de balance des volumes	26
Transpose	27
Tuning	27
Sequencer	28
• Comment utiliser le séquenceur	28
• Enregistrement	28
• Ecoute d'un enregistrement	30
• Effacer une piste	30
Programmation des fonctions	31
• Les réglages possibles sont les suivants	31
• Procédure pour effectuer ces réglages	31
MIDI	32
• Les connecteurs MIDI	32
• Exemples de branchements	32
• Les informations suivantes peuvent être reçues/transmises	33
• Assignment des canaux MIDI (MIDI CH)	33
• Les fonctions MIDI accessibles sont les suivantes	34
• Procédure pour effectuer les réglages MIDI	34
• Transmission des numéros de PROGRAM CHANGE	35
Bornier de connexions	36
Symptômes qui sembleraient être dus à un problème	36
Précautions d'utilisation	37
Assemblage	110
MIDI Implementation Chart	111
Spécifications	112

Specifications

	SX-PX111
KEYBOARD	88 KEYS (POLYPHONIC 32 NOTES)
SOUNDS	GRAND PIANO, UPRIGHT PIANO, E PIANO 1, E PIANO 2, HARPSI, PIPE ORGAN
PEDAL	SOFT/SOSTENUTO, SUSTAIN
DIGITAL CELESTE	○
DIGITAL REVERB	○ (ROOM, STAGE, HALL)
TOUCH SENSITIVITY	LIGHT, NORMAL, HEAVY
TRANSPOSE	G-C-F#
TUNING	427.3-440.0-453.0 Hz
SEQUENCER	TRACK (1, 2), STORAGE CAPACITY: APPROX. 4000 NOTES, RECORDING MODE: REAL TIME
DEMO	○
MIDI	MULTI TIMBRE, LOCAL CONTROL, OMNI ON, PROGRAM CHANGE, TRANSPOSE
MODE SET	PIANO TUNING, MINIMUM RANGE, SOSTENUTO
OTHERS	POWER SWITCH, MAIN VOLUME, MIDI TERMINALS (IN, OUT, THRU), PEDAL IN, AUX IN (R/R+L, L), LINE OUT (R/R+L, L), PHONES x 2, AC IN, INITIAL KEY
OUTPUT	25 W x 2
SPEAKERS	14 cm x 2
POWER REQUIREMENT	145 W
	90 W (NORTH AMERICA AND MEXICO)
	AC120/220/240 V 50/60 Hz
	AC120 V 60 Hz (NORTH AMERICA AND MEXICO) AC230 V 50/60 Hz (NEW ZEALAND AND EUROPE EXCEPT FOR UNITED KINGDOM) AC230-240 V 50/60 Hz (UNITED KINGDOM)
DIMENSIONS (WxHxD)	142.4 cm x 101.6 cm x 59.0 cm (56-1/16" x 40" x 23-7/32")
NET WEIGHT	50 kg (110.2 lbs.)
ACCESSORIES	MUSIC STAND, AC CORD, STAND

*Design and specifications are subject to change without notice.

MIDI Implementation Chart

[SX-PX111]

Function		Transmitted	Recognized	Remarks
Basic Channel	Default Changed	1-16 1-16	1-16 1-16	memorized
Mode	Default Messages Altered	3 x —	1, 3 x —	memorized
Note Number	True voice	*21-108 —	0-127 *0-127	
Velocity	Note ON Note OFF	○ x (9nH: V=0)	○ x	
After Touch	Key's Ch's	x x	x x	
Pitch Bender		x	x	
Control Change	7 64 66 67 93	x ○ ○ ○ ○	**○ ○ ○ ○ ○	volume sustain pedal sostenuto pedal soft pedal chorus (digital celeste)
Prog Change	True #	○x 0-127	○x 0-5	
System Exclusive		x	x	
System Common	Song Pos Song Sel Tune	x x x	x x x	
System Real Time	Clock Commands	x x	x x	
Aux Messages	Local ON/OFF All Notes OFF Active Sense Reset	x x ○ x	x ○ ○ x	
Notes	○x Whether or not the data for each of these items is transmitted or received can be set. * Changes depending on the TRANSPOSE setting. ** Effective only in the MULTI TIMBRE mode.			

Mode 1: OMNI ON, POLY
Mode 3: OMNI OFF, POLY

Mode 2: OMNI ON, MONO
Mode 4: OMNI OFF, MONO

○ : Yes
 x : No

Assembly

- Assemble your Technics piano as shown in the following diagrams.
- To disassemble the piano, reverse the procedure.
- To prevent the piano from falling off the stand, secure it firmly with the bolts.

Assemblage

- Assemblez votre piano Technics comme le montrent les figures ci-après.
- Inversez la procédure pour le démontage.
- Assurez-vous que les vis soient serrées fermement afin que l'assemblage soit stable.

Montaje

- Lleve a cabo el montaje de su piano Technics como se indica en las ilustraciones siguientes.
- Para desmontar el piano, siga el procedimiento a la inversa.
- Para prevenir que el piano caiga del soporte, asegúrelo firmemente con los pernos.

Installatie

- Installeer uw Technics piano als aangegeven in de volgende afbeeldingen.
- Voer de handelingen in omgekeerde volgorde uit voor het demonteren van de piano.
- Vergrendel de piano stevig met de bouten, zodat deze niet van de standaard kan vallen.

Montaggio

- Montaggio del pianoforte Technics come mostrato nelle figure seguenti.
- Procedura opposta di smontaggio del pianoforte.
- Per evitare che il pianoforte cada dal suo supporto, fissatelo saldamente con i bulloni.

裝配

- Technics鋼琴應按照圖示裝配。
- 拆卸時，宜與它相反的次序實行。
- 鋼琴主體應用螺栓緊固在架臺上，以免鬆動落下。

1

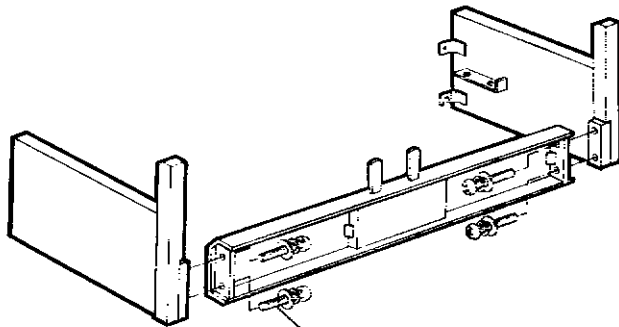

Brass-colored
Couleur laiton
Color cobre
Koperkleurig
Colore ottone
黃銅色

2

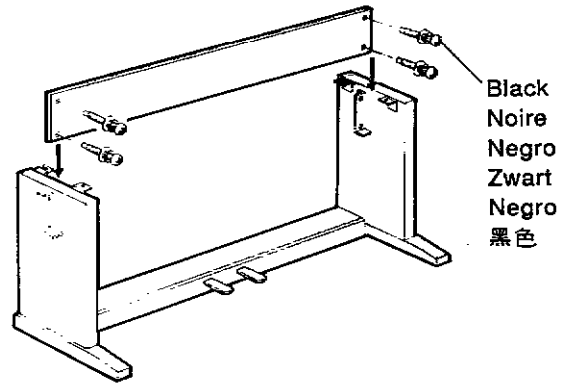

Black
Noire
Negro
Zwart
Negro
黑色

3

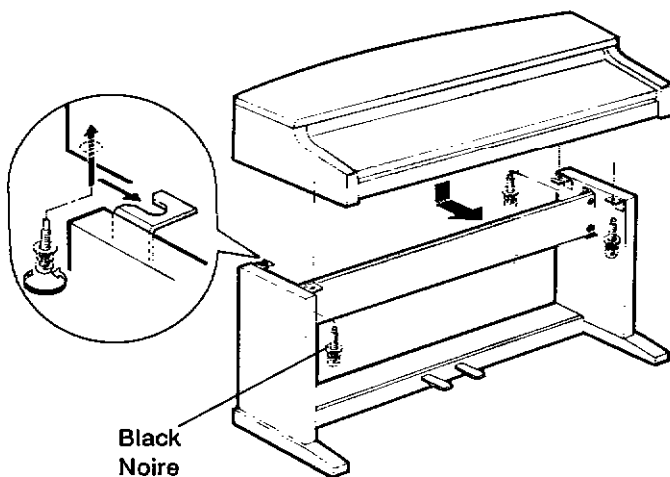

Black
Noire
Negro
Zwart
Negro
黑色

4

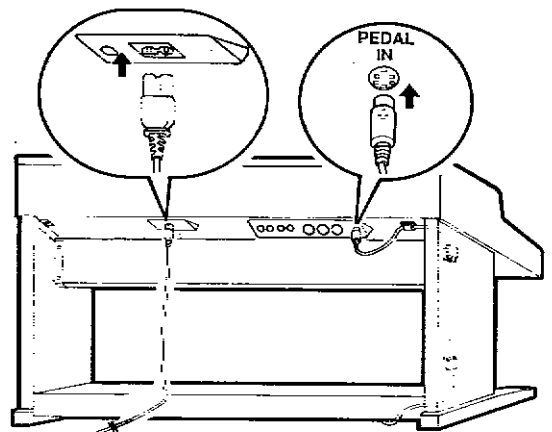

安全須知

設置地點

1. 應選擇空氣流通好的場所
本器必須選擇空氣流通好的場所，不可設置在太悶的地方，也要注意不使窗簾等堵塞通風孔。
2. 應避免設置在曝曬陽光、靠近暖房設備的地方。
3. 應避開多濕、振動、灰塵大的場所。

電源

1. 接通電源插頭之前，要確驗機器電壓選擇器的數值是否與居住地域的電壓相對一致。
2. 不可使用DC(直流)電壓。

電源線的操作

1. 濡濕的手不可接觸到供電的軟線或插頭。
2. 不可扯拉電源線。

機器內部不可插進金屬物體，以避免觸電、故障等意外事故。

樂器內部不可插進金屬物體。

尤其注意不讓兒童們無意放進雜物、金屬物質等，以防招致故障。

萬一樂器內部混進金屬物體，應立即拔掉電源連接軟線，斷掉電源之後，向經銷店聯系。

琴內進水

先由插座拔出供電線的插頭，然後應向原購買經銷店聯絡。

為防止意外故障，最好樂器上不擺花瓶、水壺等為要。

發現裝置產生反常動作時：

應立即斷開電源開關，由插座拔掉供電線，並向經銷店聯絡。

發生反常動作之後不可使用，否則會招致重大故障，甚至產生別的故障、事故等。

- 因在裝置內裝配有電源，機櫃內部會稍微發熱。

供電線、軟線的操作注意：

供電線、電線上發現斷線、損傷、接觸不良等，不可繼續使用，否則容易產生火災、觸電等事故。電源軟線不可勉強彎曲，免得損傷；損傷的軟線決不可用於任何電器。

不可觸及裝置內部：

裝置內部有帶電和高壓部分，故不該拆掉頂部面板、背面面板；更不可手指、工具等來觸及內部。

如需進行檢驗內部結構以及更換保險絲等工作，有資格維修電器人員才可實行，不准客戶自己辦修理。

維修・保養：

請嚴守以下各項注意，以使裝置保持最佳狀態。

- 每次用完後關閉開關，也為避免電子元件受到過載，不該把開關快而連續進行接/斷操作。
- 鋼琴表面和電鈕類，日常要用乾淨、潤濕的布來揩拭，再用柔軟且乾燥的布料來擦光，便能長期保持光滑狀態。擦光時可以使用光澤劑，不應使用香蕉水(稀納水)及化學藥品。
- 外殼表面不妨使用石蠟系光澤劑，但只用柔軟的乾布擦光，也能得到良好效果。

維修・保養作業，限於有資格的維修服務員才可實行，需要時請向經銷店聯系。