

VT-1 VOICE TRANSFORMER

Owner's Manual



Thank you for purchasing the BOSS VT-1 Voice Transformer.

In order to take full advantage of the VT-1's functionality, and to enjoy years of trouble-free service, please read this owner's manual carefully.

USING THE UNIT SAFELY

INSTRUCTIONS FOR THE PREVENTION OF FIRE, ELECTRIC SHOCK, OR INJURY TO PERSONS

About WARNING and CAUTION Notices

	WARNING	Used for instructions intended to alert the user to the risk of death or severe injury should the unit be used improperly.
	CAUTION	Used for instructions intended to alert the user to the risk of injury or material damage should the unit be used improperly. * Material damage refers to damage or other adverse effects caused with respect to the home and all its furnishings, as well to domestic animals or pets.

About the Symbols

	The symbol alerts the user to important instructions or warnings. The specific meaning of the symbol is determined by the design contained within the triangle. In the case of the symbol at left, it is used for general cautions, warnings, or alerts to danger.
	The symbol alerts the user to items that must never be carried out (are forbidden). The specific thing that must not be done is indicated by the design contained within the circle. In the case of the symbol at left, it means that the unit must never be disassembled.
	The symbol alerts the user to things that must be carried out. The specific thing that must be done is indicated by the design contained within the circle. In the case of the symbol at left, it means that the power-cord plug must be unplugged from the outlet.

ALWAYS OBSERVE THE FOLLOWING

	WARNING	<ul style="list-style-type: none"> Before using this unit, make sure to read the instructions below, and the Owner's Manual. Do not open (or modify in any way) the unit or its AC adaptor. Do not attempt to repair the unit, or replace parts within it (except when this manual provides specific instructions directing you to do so). Refer all servicing to your dealer, or qualified Roland service personnel. Never use or store the unit in places that are: <ul style="list-style-type: none"> Subject to temperature extremes (e.g., direct sunlight in an enclosed vehicle, near a heating duct, on top of heat-generating equipment); or are Damp (e.g., baths, washrooms, on wet floors); or are Humid; or are Dusty; or are Subject to high levels of vibration. This unit should be used only with a rack or stand that is recommended by Roland. When using the unit with a rack or stand recommended by Roland, the rack or stand must be carefully placed so it is level and sure to remain stable. If not using a rack or stand, you still need to make sure that any location you choose for placing the unit provides a level surface that will properly support the unit, and keep it from wobbling. Be sure to use only the AC adaptor supplied with the unit. Also, make sure the line voltage at the installation matches the input voltage specified on the AC adaptor's body. Other AC adaptors may use a different polarity, or be designed for a different voltage, so their use could result in damage, malfunction, or electric shock. Avoid damaging the power cord. Do not bend it excessively, step on it, place heavy objects on it, etc. A damaged cord can easily become a shock or fire hazard. Never use a power cord after it has been damaged.
	WARNING	<ul style="list-style-type: none"> This unit, either alone or in combination with an amplifier and headphones or speakers, may be capable of producing sound levels that could cause permanent hearing loss. Do not operate for a long period of time at a high volume level, or at a level that is uncomfortable. If you experience any hearing loss or ringing in the ears, you should immediately stop using the unit, and consult an audiologist. Do not allow any objects (e.g., flammable material, coins, pins); or liquids of any kind (water, soft drinks, etc.) to penetrate the unit. Immediately turn the power off, remove the AC adaptor from the outlet, and request servicing by your dealer or qualified Roland service personnel when: <ul style="list-style-type: none"> The AC adaptor or the power-supply cord has been damaged; or Objects have fallen into, or liquid has been spilled onto the unit; or The unit has been exposed to rain (or otherwise has become wet); or The unit does not appear to operate normally or exhibits a marked change in performance. In households with small children, an adult should provide supervision until the child is capable of following all the rules essential for the safe operation of the unit. Protect the unit from strong impact. (Do not drop it!) Do not force the unit's power-supply cord to share an outlet with an unreasonable number of other devices. Be especially careful when using extension cords- the total power used by all devices you have connected to the extension cord's outlet must never exceed the power rating (watts/amperes) for the extension cord. Excessive loads can cause the insulation on the cord to heat up and eventually melt through. Before using the unit in a foreign country, consult with your dealer, or qualified Roland service personnel.

Before using this unit, carefully read the sections entitled: "USING THE UNIT SAFELY" and "IMPORTANT NOTES." These sections provide important information concerning the proper operation of the unit. Additionally, in order to feel assured that you have gained a good grasp of every feature provided by your new unit, this manual should be read in its entirety. The manual should be saved and kept on hand as a convenient reference.

	CAUTION	<ul style="list-style-type: none"> The unit and the AC adaptor should be located so their location or position does not interfere with their proper ventilation. Always grasp only the plug or the body of the AC adaptor when plugging into, or unplugging from, an outlet or this unit. Whenever the unit is to remain unused for an extended period of time, disconnect the AC adaptor. Try to prevent cords and cables from becoming entangled. Also, all cords and cables should be placed so they are out of the reach of children. Never climb on top of, nor place heavy objects on the unit.
	CAUTION	<ul style="list-style-type: none"> Never handle the AC adaptor body, or its plugs, with wet hands when plugging into, or unplugging from, an outlet or this unit. Before moving the unit, disconnect the AC adaptor and all cords coming from external devices. Before cleaning the unit, turn off the power and unplug the AC adaptor from the outlet. Whenever you suspect the possibility of lightning in your area, disconnect the AC adaptor from the outlet.

IMPORTANT NOTES

In addition to the items listed under "USING THE UNIT SAFELY," please read and observe the following:

Power Supply

- Do not use this unit on the same power circuit with any device that will generate line noise (such as an electric motor or variable lighting system).

Placement

- The AC adaptor will begin to generate heat after long hours of consecutive use. This is normal, and is not a cause for concern.
- Before connecting this unit to other devices, turn off the power to all units. This will help prevent malfunctions and/or damage to speakers or other devices.
- This device may interfere with radio and television reception. Do not use this device in the vicinity of such receivers.

Maintenance

- For everyday cleaning wipe the unit with a soft, dry cloth or one that has been slightly dampened with water. To remove stubborn dirt, use a mild, non-abrasive detergent. Afterwards, be sure to wipe the unit thoroughly with a soft, dry cloth.
- Never use benzene, thinners, alcohol or solvents of any kind, to avoid the possibility of discoloration and/or deformation.

Additional Precautions

- Use a reasonable amount of care when using the unit's buttons, sliders, or other controls; and when using its jacks and connectors. Rough handling can lead to malfunctions.
- To avoid disturbing your neighbors, try to keep the unit's volume at reasonable levels (especially when it is late at night).
- When you need to transport the unit, package it in the box (including padding) that it came in, if possible. Otherwise, you will need to use equivalent packaging materials.

For the U.K.

IMPORTANT: THE WIRES IN THIS MAINS LEAD ARE COLOURED IN ACCORDANCE WITH THE FOLLOWING CODE.

BLUE: NEUTRAL
BROWN: LIVE

As the colours of the wires in the mains lead of this apparatus may not correspond with the coloured markings identifying the terminals in your plug, proceed as follows:
The wire which is coloured BLUE must be connected to the terminal which is marked with the letter N or coloured BLACK.
The wire which is coloured BROWN must be connected to the terminal which is marked with the letter L or coloured RED.
Under no circumstances must either of the above wires be connected to the earth terminal of a three pin plug.

For EU Countries



This product complies with the requirements of European Directives EMC 89/336/EEC and LVD 73/23/EEC.

For the USA

FEDERAL COMMUNICATIONS COMMISSION RADIO FREQUENCY INTERFERENCE STATEMENT

This equipment has been tested and found to comply with the limits for a Class B digital device, pursuant to Part 15 of the FCC Rules. These limits are designed to provide reasonable protection against harmful interference in a residential installation. This equipment generates, uses, and can radiate radio frequency energy and, if not installed and used in accordance with the instructions, may cause harmful interference to radio communications. However, there is no guarantee that interference will not occur in a particular installation. If this equipment does cause harmful interference to radio or television reception, which can be determined by turning the equipment off and on, the user is encouraged to try to correct the interference by one or more of the following measures:

- Reorient or relocate the receiving antenna.
- Increase the separation between the equipment and receiver.
- Connect the equipment into an outlet on a circuit different from that to which the receiver is connected.
- Consult the dealer or an experienced radio/TV technician for help.

Unauthorized changes or modification to this system can void the users authority to operate this equipment. This equipment requires shielded interface cables in order to meet FCC class B Limit.

For Canada

NOTICE

This Class B digital apparatus meets all requirements of the Canadian Interference-Causing Equipment Regulations.

AVIS

Cet appareil numérique de la classe B respecte toutes les exigences du Règlement sur le matériel brouilleur du Canada.

Copyright © 1996 BOSS Corporation

All rights reserved. No part of this publication may be reproduced in any form without the written permission of BOSS CORPORATION.

00904990 '01-10-C2-41N

Panel Descriptions

< Top Panel >

Bank Buttons / Bank Indicators

These buttons are used to select memory banks; they switch between the Preset bank and the User bank.

Preset bank: This bank contains preset voice characters. It is not possible to re-write the contents of these memories.

User bank: Voice characters that you create using the sliders and the ROBOT button can be stored in these memories.

PEAK Indicator

This indicator lets you check the microphone input level. If the indicator lights frequently, lower the input level by adjusting the INPUT LEVEL knob located on the rear panel.

* The PEAK indicator will light 6 dB below the clipping point (the level at which distortion will begin).

* If the PEAK indicator lights too frequently, the proper effect will not be obtained.

ROBOT Button / Robot Indicator

This button turns the Robot function on/off. When the Robot function is on, the Robot indicator will light.

When the Robot function is on, the voice will be output at a fixed pitch (regardless of the input pitch), producing a flat voice character without intonation.

PITCH Slider

This slider adjusts the pitch of the voice character. The pitch can be adjusted over a range of +/- one octave.

FORMANT Slider

Formants are fixed frequency regions of emphasis that are an important element in determining how a voice sounds. This slider adjusts the formants. Raising the slider produces a voice character that sounds as if the vocal cords have become 'smaller.' Lowering the slider produces a voice character that sounds as if the vocal cords have become 'larger.'

Number Buttons / Number Indicators

These buttons are used to select memory positions 1 – 4; the indicator of the selected number will light. When you move the sliders or press the ROBOT button, the number indicator will blink to indicate that the voice character is now different than the contents of the memory.

WRITE Button

This button is used to write (store) the current voice character settings into memory (the USER bank).

Write procedure

Here's how to write a voice character that you've created into memory (USER bank). By storing a voice character in memory, you can later re-select it at the touch of a button.

1. Move the sliders and/or press the ROBOT button to create the desired voice character.
2. Press the WRITE button. The bank (USER) and number indicators will blink.
3. Press a number button (1 – 4) to select the desired storage destination; the number indicator will blink.
4. Press the WRITE button once again. The voice character will be stored in the number you selected in step 3.

* By pressing the WRITE button without moving the sliders or pressing the ROBOT button, you can copy the currently selected voice character to another USER number.

* If during the Write procedure you decide to cancel the operation, hold down the BYPASS button and press the WRITE button. You will return to where you were before starting the Write procedure.

BYPASS Button / Bypass Indicator

This button switches the bypass function on/off.

When bypass is on, the BYPASS indicator will light, and the voice character and reverb will be turned off so that the input sound is output without change.

If you use the REMOTE jack to turn off the voice character (while leaving the reverb unaffected), the Bypass indicator will blink.

REVERB Slider

This slider adjusts the volume of the reverberation sound.

Main Features

A vocal effector that independently controls basic pitch and formants

When pitch is shifted using a conventional pitch shifter, the formants (regions of spectral emphasis determined by the size of the vocal cords) are also shifted. This means that raising the pitch produces a "chipmunk voice," as if the vocal cords had become smaller. Conversely, lowering the pitch produces a "giant voice," as if the vocal cords had become larger.

The VT-1 controls basic pitch and formants independently, allowing a variety of voice characters (characteristic types of voice) to be created.

Special effects using the ROBOT button

The ROBOT button fixes the vocal pitch to produce a special effect like that of a robot speaking.

Memory Function

Voice character settings can be stored in memory. At the touch of a button, you can select User voice characters or Preset voice characters to switch between a variety of sounds.

High-Quality Reverb

The on-board reverb is of a quality that rivals dedicated reverb processors; the ideal reverb for your vocal part is always available.

REMOTE Jack

A REMOTE jack is provided, allowing you to turn the voice character function on/off with a foot switch, without affecting the reverb.

Connections

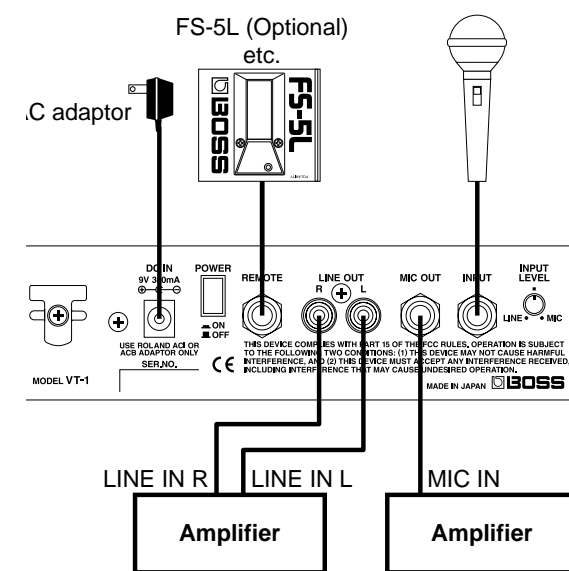

* To prevent malfunction and/or damage to speakers or other devices, always turn down the volume, and turn off the power on all devices before making any connections.

* Once the connections have been completed, turn on power to your various devices in the order specified. By turning on devices in the wrong order, you risk causing malfunction and/or damage to speakers and other devices.

VT-1 → Amplifier

Selecting Preset Memories

You can choose from five voice character types as appropriate for your musical or performance situation. The voice character memories will be given settings of the selected type. At this time, the contents of the USER bank will also be re-written.

If All Memory Type is selected, you will be able to freely modify the settings of the PRESET bank just as with the USER bank.

(Procedure)

1. Turn the power off.
2. While holding down the button for the desired type, turn the power on again.
3. While the Preset indicator and the User indicator are lit, press the WRITE button.

The voice character memories will be given settings of the selected type:

{ [BANK]: Standard Settings }

{ [1]: Vocal Applications with reverb }

{ [2]: Vocal Applications with non-reverb }

{ [3]: Narrations / DJ Performance Settings }

{ [4]: Animation Character Settings }

{ [ROBOT]: All memory types }

< Rear Panel >

Cord Hook

Loop the AC adaptor cord around this hook; this will help prevent damage to the cable and help prevent accidental disconnection.

* To prevent the inadvertent disruption of power to your unit (should the plug be pulled out accidentally), and to avoid applying undue stress to the AC adaptor jack, anchor the power cord using the cord hook, as shown in the illustration.

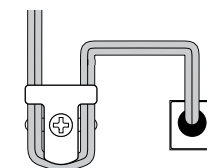

LINE OUT L/R Jacks

These are output jacks (stereo, RCA phono type) for connecting the output of the VT-1 to the line input jacks of an external device.

AC Adaptor Jack

Connect the included AC adaptor (ACI/ACB Series) to this jack.

REMOTE Jack

This jack is for connecting a foot switch (BOSS FS-5L; optional). A foot switch allows you to turn the voice character function on/off without affecting the reverb component.

INPUT Jack

This is an (unbalanced) input jack for connecting a microphone, etc.

* Howling could be produced depending on the location of microphones relative to speakers. This can be remedied by:

1. Changing the orientation of the microphone(s).
2. Relocating microphone(s) at a greater distance from speakers.
3. Lowering volume levels.

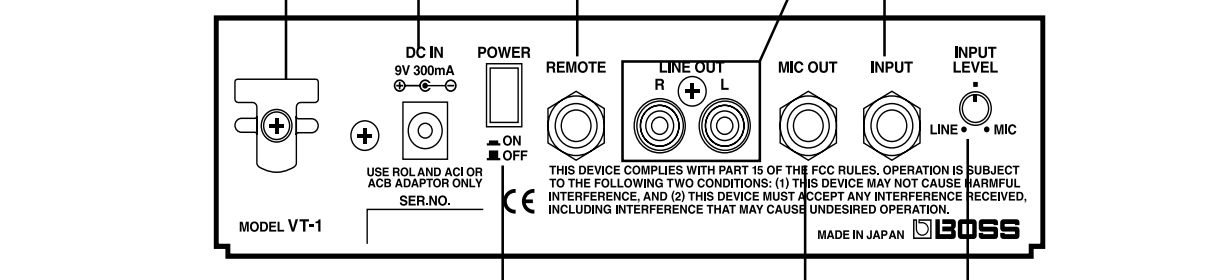

POWER Switch

This switch turns the VT-1 on/off.

* This unit is equipped with a protection circuit. A brief interval (a few seconds) after power up is required before the unit will operate normally.

MIC OUT Jack

This is an output jack (mono, unbalanced) for connecting the output of the VT-1 to the microphone input jack of an external device.

INPUT LEVEL Knob

This knob adjusts the input level. Set this knob so that when the input voice is at its loudest, the PEAK indicator lights briefly.

* The input level must be adjusted carefully. If the PEAK indicator lights too frequently or not at all, the correct effect will not be obtained.

Preset Memories Table

Standard Settings

PRESET	1: High Tone	2: Low Tone 2	3: Kids	4: Computer Voice
USER	1: Duck	2: Big Monster	3: Space Invader	4: Robot

Vocal Applications with reverb

PRESET	1: Normal Voice	2: Detune; Up	3: Duet; High	4: +3rd
USER	1: Normal Voice	2: Detune; Down	3: Duet; Low	4: +5th

Vocal Applications with non-reverb

PRESET	1: Normal Voice	2: Detune; Up	3: Duet; High	4: +3rd
USER	1: Normal Voice	2: Detune; Down	3: Duet; Low	4: +5th

Narrations / DJ Performance Settings

PRESET	1: Low Tone 1	2: Low Tone 2	3: High Tone	4: Computer Voice
USER	1: Low Tone 1	2: Low Tone 2	3: High Tone	4: Computer Voice

Animation Character Settings

PRESET	1: Duck	2: Big Monster	3: Kids	4: Robot
USER	1: Chipmunk	2: Big Bear	3: Space Invader	4: Big Robot

Sample Settings

- 1: Usual setup for transforming a man's voice to a woman's.
- 2: Lowering a man's voice by an octave. Can be used to make a woman's voice sound like a man's.
- 3: Centering the Mix Balance slider lets you mix a man's dry voice together with the same voice transformed into a woman's for a duet. Add reverb effect.
- 4: Robot Mode

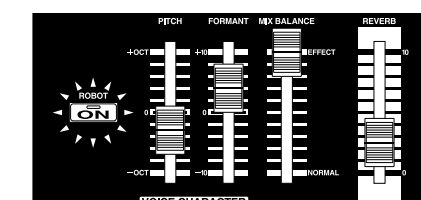
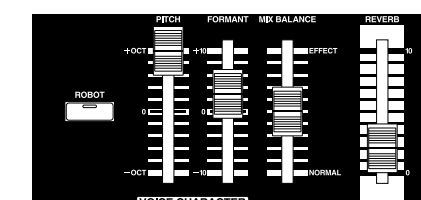
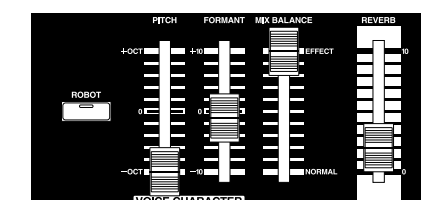
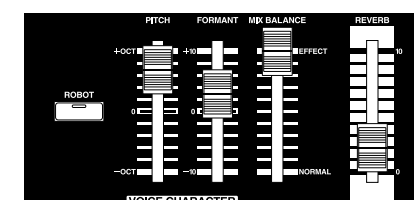

Hints for voice input

- Input only a single voice. If several voices are input, the VT-1 will not operate properly.
- Be sure that sound from a speaker does not enter the microphone you are using. This will have the same effect as if several voices were input to the unit (i.e. the VT-1 will not function properly).
- We recommend that you use a unidirectional microphone; speak or sing as close to the microphone as possible.

Specifications

Nominal Input Level
-50 dBu (INPUT LEVEL: MIC)
-20 dBu (INPUT LEVEL: LINE)

Input Range
62.5 Hz – 1 kHz (C2 – B5)

Nominal Output Level
-40 dBu (MIC OUT)
-20 dBu (LINE OUT)

Residual Noise
-100 dBu or less (INPUT LEVEL: MIC) (IHF-A)

Controls

Bank Button
Number Buttons (1, 2, 3, 4)
BYPASS Button
WRITE Button
ROBOT Button
PITCH Slider
FORMANT Slider
MIX BALANCE Slider
REVERB Slider
INPUT LEVEL Knob
POWER Switch

Indicators

PEAK Indicator
Bank Indicators (Preset, User)
Number Indicators (1, 2, 3, 4)
BYPASS Indicator
ROBOT Indicator

Connectors

INPUT Jack
MIC OUT Jack
LINE OUT Jacks L/R
REMOTE Jack
AC Adaptor Jack

Power Supply

DC 9 V: AC adaptor (ACI/ACB Series)

Current Draw

300 mA

Dimensions

178 (W) x 161.5 (D) x 52 (H) mm
7 (W) x 6-3/8 (D) x 2-1/16 (H) inches

Weight

480 g / 1 lb 1 oz (excluding AC adaptor)

Included Items

AC adaptor (ACI/ACB Series)
Owner's Manual
Roland Service (information sheet)

* 0 dBu = 0.775 Vrms

* In the interest of product improvement, the specifications and/or appearance of this unit are subject to change without prior notice.