

Roland®

24-BIT DIGITAL STUDIO RECORDER

VSR-880

USER GUIDE

Before using this unit, carefully read the sections entitled: "IMPORTANT SAFETY INSTRUCTIONS" (Owner's Manual p. 2), "USING THE UNIT SAFELY" (Owner's Manual p. 3, 4), and "IMPORTANT NOTES" (Owner's Manual p. 5). These sections provide important information concerning the proper operation of the unit. Additionally, in order to feel assured that you have gained a good grasp of every feature provided by your new unit, *** should be read in its entirety. The manual should be saved and kept on hand as a convenient reference.

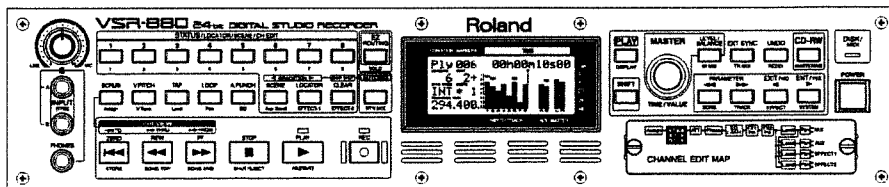

Copyright © 1999 ROLAND CORPORATION

All rights reserved. No part of this publication may be reproduced in any form without the written permission of ROLAND CORPORATION.

Roland International Website <http://www.roland.co.jp/>

Contents

Contents	2
Preparations	5
Required Preparations.....	5
Installing Optional Devices	5
Cautions Concerning Installation of Optional Devices.....	5
Installing an Internal Hard Disk (HDP88 series)	6
Installing an Effects Expansion Board (VS8F-2).....	7
Installation de dispositifs optionnels	8
Précautions à prendre lors de l'installation de dispositifs optionnels.....	8
Installer un disque dur (série HDP88).....	9
Installation de la carte d'extension d'effets.....	10
Basic Connections	11
Operation From the Front Panel	11
Connecting Mixers and Audio Devices.....	11
Connecting Microphones and Instruments	11
Connecting the Roland VM-3100Pro	12
Connecting the Roland VM-7200/7100	12
Operation From the Roland Digital Mixer.....	13
Connecting the Roland VM-3100Pro	13
Connecting the Roland VM-7200/7100	13
Connecting the Roland DIF-AT (R-BUS).....	14
Connecting the ALESIS adat	14
Connecting the TASCAM DA Series	14
Turning On the Power.....	15
Adjusting the Display Contrast	15
If You Have Trouble Understanding Displays or Operations	15
Resetting Mixer and System Settings to Their Original State	16
Turning Off the Power (Shutdown)	16
If "STORE Current?" is Displayed.....	17
Listening to the Demo Song	18
Determining Output (Direct Out).....	18
Playing Back the Demo Song	19
Viewing the Level Meters and Playlists	19
Adjusting the Overall Volume.....	21
Adjusting the Volume of an Individual Track	21
Adjusting the Headphone Volume	22
Listening to the Demo Song with a Different Arrangement (Scene).....	22
Preparations for multi-track recording	23
Creating a New Song (Song New).....	23
About Recording Time.....	24
If "Drive Busy!" is Displayed.....	25
Song Numbers.....	25
Selecting a Song (Song Select)	26
Changing the Name of the Song (Song Name).....	27
Making a Multi-Track Recording¹ (Using Front Panel)	28
Adjusting the Input Sensitivity	28
Recording On a Track.....	30
Playing Back the Performance You Recorded	32
Recording on V-Track	33
Switching V-Tracks.....	33
Comparing the Recorded Content of Two V-Tracks.....	34
Switching V-Track Bank	35

Recording On Other Tracks (Overdubbing).....	36
Recording Digital Signals.....	38
Items Necessary for Digital Recording.....	38
Make the Digital Connections.....	38
Match the Sample Rates.....	38
In Order to Make a Digital Connection with Your CD Player.....	38
To Prevent Digital Connections with CD Players.....	39
Select the Master Clock.....	39
Select an Input Source.....	40
Playing Back Two or More Tracks.....	42
Adjusting the Stereo Position of Each Track.....	42
Adjusting the Tone of Each Track.....	43
Canceling the Recording.....	45
Checking the Time Available for Recording (Remaining Time).....	45
Canceling a Recorded Result (Undo/Redo).....	46
Re-Recording a Specified Portion (Punch-In/ Punch-Out).....	47
Erasing Just a Portion of a Recording (Track Erase).....	48
If "Disk Full!" appears in the display (Song Optimize).....	49
Saving Your Performance (Song Store).....	50
Protecting Songs (Song Protect).....	51
To Remove Song Protect.....	52

Making a Multi-Track Recording 2 (Using the Roland Digital Mixer)53

Using the R-BUS (INPUT 1-8/OUTPUT 1-8).....	53
Preparations for using the R-BUS.....	53
Adjusting the Input Sensitivity.....	54
Recording On a Track.....	56
Playing Back the Performance You Recorded.....	58
Using the front panel input jacks (INPUT A/B).....	58
Adjusting the Input Sensitivity.....	59
Recording On Other Tracks (Overdubbing).....	60

Using Effects (VS8F-2)62

Applying a Send/ Return Type Effect During Playback.....	62
Applying a Send/ Return Type Effect Only to the Monitor Sound as You Record.....	64
Switching Effects During Playback.....	66
Applying a Send/ Return Type Effect While You Record.....	68
Applying an Insertion-Type Effect During Playback.....	71
Inserting the Same Effect into Another Track as Well.....	73
If You Wish to Use the Same Effect Both as Send/ Return and Insertion.....	73
Applying an Insertion-Type Effect During Recording.....	74

Add Finishing Touches to Your Song.....77

Combining the Performances of Multiple Tracks (Track Bouncing).....	77
Create Master Data (Mastering Room).....	81
Mixdown to Mastering Tracks.....	81
Playing back the mastering tracks.....	84
Erasing an Unwanted Portion (Track Cut).....	85
Selecting the Portion that will be Written to the CD-R Disc.....	85
Deleting an Unwanted Portion At the End of the Song.....	86
Deleting an Unwanted Portion At the Beginning of the Song.....	87
Adding Track Number Markers.....	88
Assigning Track Numbers.....	89

Contents

Creating an Original Audio CD (CD-R Write)	90
Connecting the CD-RW Drive	90
Creating an Audio CD (CD-R Write)	91
Auditioning (Test Listening) Songs Written to CDs (CD Player Function).....	94
Saving Songs to CD-RW Discs	96
Backup the song (CD-RW backup)	96
Loading Songs From CD-RW Discs(CD-RW recover)	98
How to Erase the Data in the CD-RW Disc	99
Appendices	100
Deleting Unneeded Songs (Song Erase).....	100
Confirming That a Drive is Not Damaged (Drive Check).....	101
If the display indicates "No Err"	102
If the display indicates "___ Err"	102
Change partitions (Drive Select)	105
Initializing the Disk (Drive Initialize).....	106
Checking Disk Reliability (Surface Scan).....	108
Index	109

Preparations

Required Preparations

The VSR-880 is an audio recorder that allows multi-track recording to a hard disk. To make a multi-track recording, you will need at least the following items.

- VSR-880 (1 unit)
- Power cable (1: included)
- Internal IDE hard disk (HDP88 series: sold separately in some countries)
- Audio device for master output, monitor output, or headphones (sold separately)
- Microphone or other audio source to record, such as an electric guitar, synthesizer, or CD player etc. (sold separately)

User Guide will also explain the use of the following equipment, which you may purchase as desired.

- V-Mixing Station: **VM-3100Pro**
- V-Mixing Consoles: **VM-C7200/C7100**
- V-Mixing Processors: **VM-7200/7100**
- Effects Expansion Board: **VS8F-2** (for internal installation: sold separately)
- **External CD-RW drive** (designated by Roland, sold separately)



The explanations in this manual include illustrations that depict what should typically be shown by the display. Note, however, that your unit may incorporate a newer, enhanced version of the system, so what you actually see in the display may not always match what appears in the manual.

Installing Optional Devices

■ Cautions Concerning Installation of Optional Devices

- Always turn the unit off and unplug the power cord before attempting installation of the circuit board (model no. HDP88 series, VS8F-2; p. 16).
- Install only the specified circuit board(s) (model no. HDP88 series, VS8F-2). Remove only the specified screws (p. 6, 7).
- To avoid the risk of damage to internal components that can be caused by static electricity, please carefully observe the following whenever you handle the board.
 - Before you touch the board, always first grasp a metal object (such as a water pipe), so you are sure that any static electricity you might have been carrying has been discharged.
 - When handling the board, grasp it only by its edges. Avoid touching any of the electronic components or connectors.
 - Save the bag in which the board was originally shipped, and put the board back into it whenever you need to store or transport it.
- Use a Phillips screwdriver of a size appropriate for the head of the screw (a no.2 screwdriver). If the screwdriver is the wrong size, the screw heads may be stripped, or you may not be able to turn the screws.
- To remove the screws, rotate the screwdriver counterclockwise. To tighten the screws, rotate the screwdriver clockwise.
- Take care not to drop any screws into the interior of the VSR-880's chassis.
- Do not touch any of the printed circuit pathways or connection terminals.
- Never use excessive force when installing a circuit board. If it doesn't fit properly on the first attempt, remove the board and try again.
- When circuit board installation is complete, double-check your work.



Preparations

■ Installing an Internal Hard Disk (HDP88 series)

In some countries, VSR-880's do not come with the Hard Disk installed.

A Roland **HDP88 series hard disk** (sold separately in some countries) can be installed in the VSR-880. In order to take full advantage of the VSR-880's functionality for the number of tracks that can be recorded/played back simultaneously, we recommend that you install an 2100 MB or higher model.

1. Turn off the power of the VSR-880 and of all connected devices, and disconnect all cables from the VSR-880.
2. Remove only the coin-bolts specified in the following diagram, and detach the front panel cover of the VSR-880.
3. With the warning label of the hard disk facing upward, slide it gently into the installation bay as far as it will go. You can hook the indentation of the attachment hardware over the protrusion on the chassis of the VSR-880.

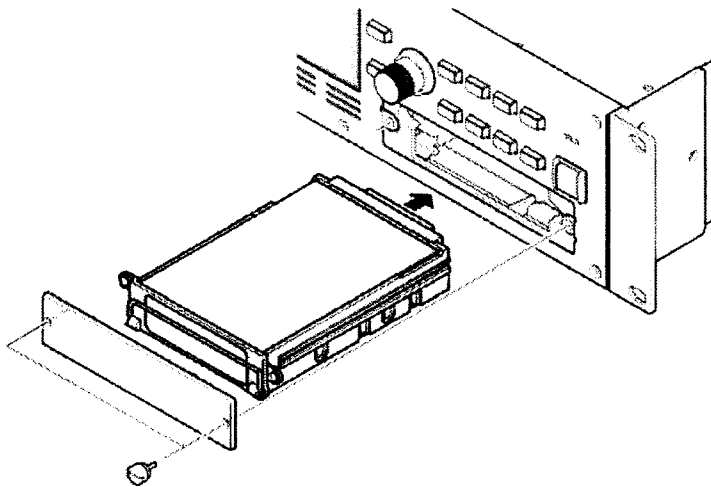

4. Fold down the handle on the front of the hard disk, and reattach the front panel cover as it originally was. This completes installation of the hard disk.
5. As described in "Turning On the Power" (p. 15), turn on the power and verify that the VSR-880 starts up correctly.

If the Display Indicates "Init.Drive = NoDrive," the internal hard disk was not recognized correctly. Use the front panel power switch to turn off the power, and re-install the hard disk correctly.

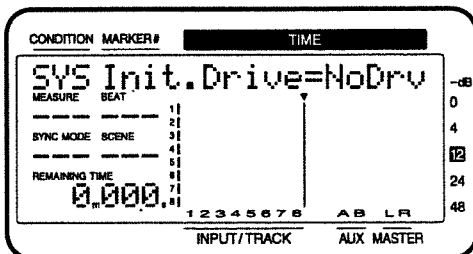

MEMO

The coin screw can be removed by hand. If it has been fastened too tightly for you to remove by hand, use a coin to loosen it.

NOTE

To avoid malfunctions, you should remove the internal hard disk before transporting the VSR-880. To remove the hard disk, reverse the procedure described in "Installing the hard disk" (p. 6). In particular when you ship the unit or when you move house, be sure to remove the hard disk from the VSR-880, place the hard disk in its packing carton, and put it in its special place inside the VSR-880 packing carton.

■ Installing an Effects Expansion Board (VS8F-2)

A **VS8F-2** effects expansion board is optionally available. When one VS8F-2 board is installed, you will be able to use up to two stereo effects without connecting any additional equipment to the VSR-880. One effects expansion board may be installed in the VSR-880. In order to take full advantage of the VSR-880's functionality, we recommend that you install at least one effects expansion board.

1. Before installing the VS8F-2, turn off the power of the VSR-880 and all connected devices, and disconnect all cables from the VSR-880.
2. Remove only the screws specified in the following diagram, and detach the top panel cover of the VSR-880.
3. Inside, there is one connector and three resin pins. Insert the connector of the VS8F-2 into the internal connector, and simultaneously insert the resin pins into the holes of the VS8F-2 to fasten the unit in place.

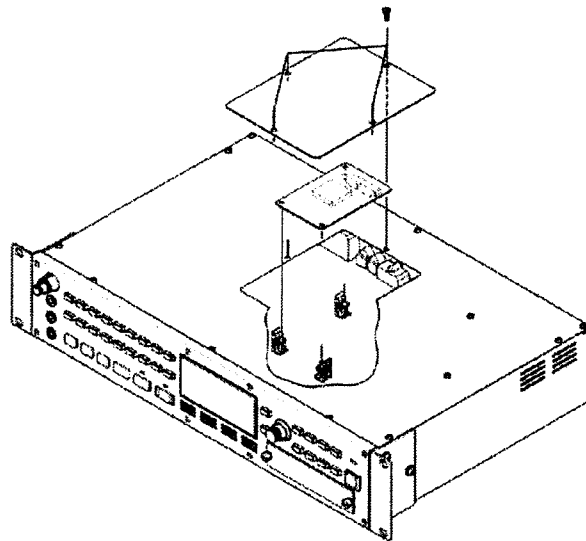

4. Use the screws that you removed in step 2 to fasten the cover back in place. This completes installation of the effects expansion board. This completes installation of the VS8F-2.
5. Turn on the power, as described in "Turning On the Power" (p. 15).
6. After the VSR-880 has finished its start up procedure, hold down **[SHIFT]** and press **[EFFECT (▶)]** to verify that the effects menu appears.

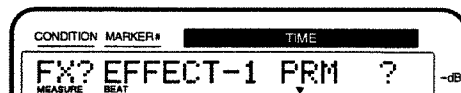

If the Display Indicates "No Effect Board," the internal effect expansion board was not detected correctly. Turn off the power (Shutdown operation), as described in "Turning Off the Power" (p. 16), and re-install the effect expansion board correctly.

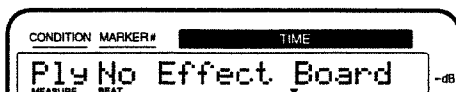

Installation de dispositifs optionnels

■ Precautions a prendre lors de l'installation de dispositifs optionnels

- Toujours éteindre et débrancher l'appareil avant de commencer l'installation de la carte. (modèle no HDP88 series; p. 16, VS8F-2; p. 16).
- N'installez que les cartes de circuits imprimés spécifiées (modèle no HDP88 series, VS8F-2). Enlevez seulement les vis indiquées (p. 6, 7).
- Veuillez suivre attentivement les instructions suivantes quand vous manipulez la carte afin d'éviter tout risque d'endommagement des pièces internes par l'électricité statique.
 - Toujours toucher un objet métallique relié à la terre (comme un tuyau par exemple) avant de manipuler la carte pour vous décharger de l'électricité statique que vous auriez pu accumuler.
 - Lorsque vous manipulez la carte, la tenir par les côtés. Évitez de toucher aux composants ou aux connecteurs.
 - Conservez le sachet d'origine dans lequel était la carte lors de l'envoi et remettez la carte dedans si vous devez la ranger ou la transporter.
- Utiliser un tournevis cruciforme correspondant à la taille de la vis (un tournevis numéro 2). En cas d'utilisation d'un tournevis inapproprié, la tête de la vis pourrait être endommagée.
- Pour enlever les vis, tourner le tournevis dans le sens contraire des aiguilles d'une montre. Pour resserrer, tourner dans le sens des aiguilles d'une montre.
- Veillez à ne pas laisser tomber de vis dans le châssis du VSR-880.
- Ne pas toucher aux circuits imprimés ou aux connecteurs.
- Ne jamais forcer lors de l'installation de la carte de circuits imprimés. Si la carte s'ajuste mal au premier essai, enlevez la carte et recommencez l'installation.
- Quand l'installation de la carte de circuits imprimés est terminée, revérifiez si tout est bien installé.



■ Installer un disque dur (serie HDP88)

Le VSR-880 s'utilise avec un disque dur Roland de la série HDP88 vendu séparément. Pour maximiser les capacités du VSR-880 -nombre de pistes lors des enregistrements et lectures simultanés ou taille de la mémoire-, il est conseillé d'utiliser un modèle supérieur au HDP88-2100.

1. Éteindre tous les appareils reliés au VSR-880 et détacher tous les câbles qui y sont reliés.
2. Enlever les vis indiquées sur le schéma suivant et détacher la plaque avant du VSR-880.
3. Orienter le disque dur de façon à ce que la face sur laquelle est collée l'étiquette de mise en garde se trouve sur le dessus. Le diriger lentement vers son emplacement en s'assurant de bien l'enfoncer jusqu'au fond. Accrocher les parties en saillie du châssis du VSR-880 aux fentes métalliques à cet effet.

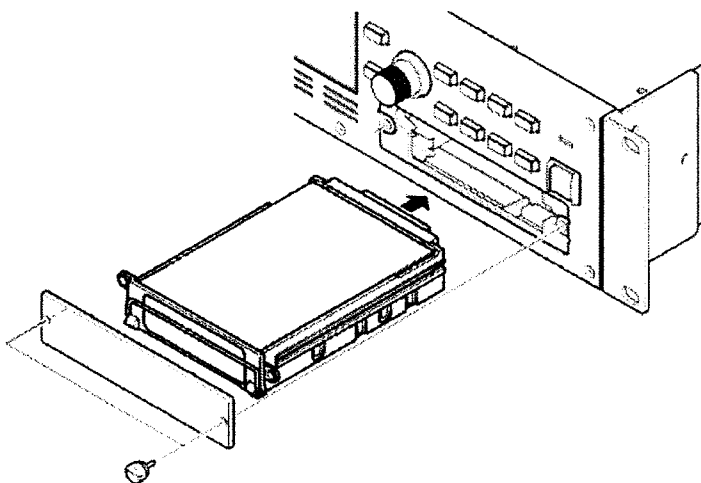

4. Après avoir replacé la poignée située sur le devant du disque dur, remettre la plaque avant. Ceci met fin à l'installation du disque dur.
5. Allumer l'appareil en suivant les instructions à cet effet à la p. 15 et s'assurer qu'il s'allume normalement.

Si le message "Init.Drive=NoDrive" s'affiche, cela signifie que le disque dur installé n'est pas reconnu correctement. Éteindre l'appareil avec le bouton arrière et recommencer l'installation du disque dur.

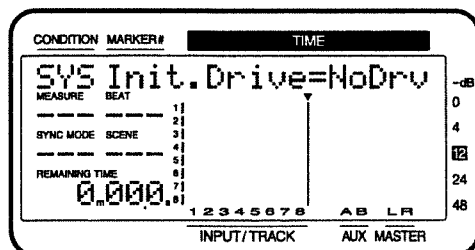

MEMO

Les vis peuvent s'enlever avec les doigts. Si elles sont trop serrées pour être dévissées avec les doigts, vous pouvez utiliser une pièce de monnaie.

NOTE

Afin d'éviter d'infliger des dommages à l'appareil lors de déplacements, enlever le disque dur installé en suivant, dans le sens contraire, les étapes de son installation de la p. 6. Il est impératif d'enlever le disque dur du VSR-880 lors de déménagements ou d'envoi. Lors de tels déplacements, ne pas oublier de bien remettre le disque dur dans son emballage d'origine et de placer le disque emballé dans l'espace prévu à cet effet dans la boîte d'emballage du VSR-880.

Preparations

■ Installation de la carte d'extension d'effets

La carte d'extension à effet VS8F-2 est vendue séparément. Si vous installez le VS8F-2, vous pourrez utiliser jusqu'à 2 systèmes d'effets stéréo par carte installée. Il est possible d'installer une carte de ce type dans le VSR-880. Pour maximiser le rendement du VSR-880, Roland vous recommande d'installer une carte VS8F-2.

1. Éteindre le VS-1680 et tous les appareils qui y sont reliés et débrancher tous les câbles du VS-1680.
2. Enlever les vis indiquées sur le schéma suivant et enlever la plaque du dessus du VSR-880.
3. Dans l'appareil, il y a un connecteur avec 3 broches en plastique. Brancher le connecteur du VS8F-2 dans le connecteur interne tout en enfonçant les broches dans les trous du VS8F-2 afin de bien fixer le tout.

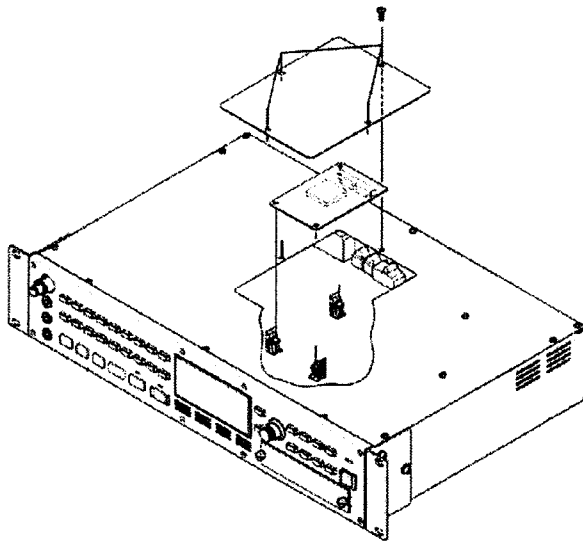

4. Reposez le couvercle en remettant les vis enlevées (comme spécifié) à l'étape 2. L'installation de la carte d'extension d'effets est terminée.
5. Mettez le VS-1680 sous tension en procédant comme indiqué dans "Turning On the Power" (p. 15).
6. Si le VS-1680 démarre correctement, appuyez sur [EFFECT (▶▶)] tout en tenant [SHIFT] enfoncé et vérifiez si le menu d'effet A apparaît à l'écran.

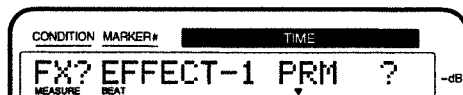

Si le message "No Effect Board" s'affiche, cela signifie que le VS8F-2 que vous avez installé n'est pas reconnu correctement. Éteindre l'appareil en suivant les instructions à la p. 16 et recommencer l'installation.

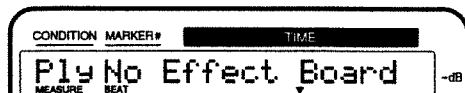

Basic Connections

Operation From the Front Panel

■ Connecting Mixers and Audio Devices

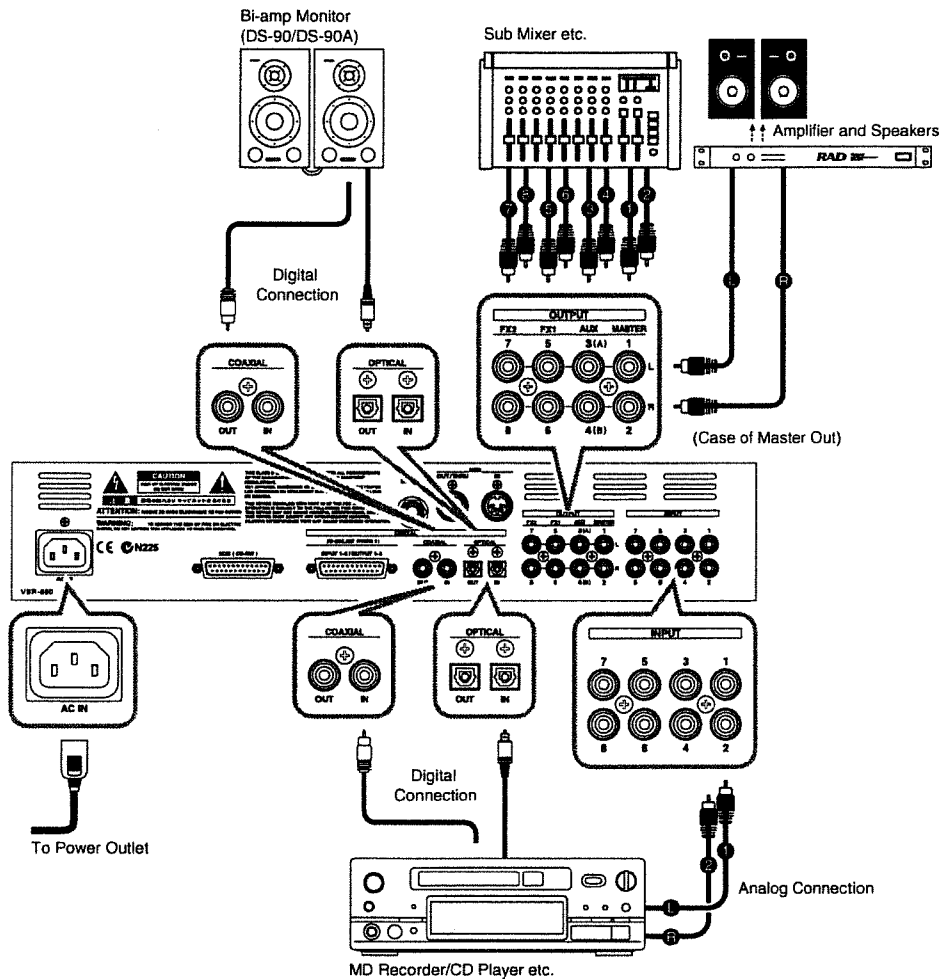

NOTE

To prevent malfunction and /or damage to speakers or other devices, always turn down the volume, and turn off the power on all devices before making any connections.



■ Connecting Microphones and Instruments

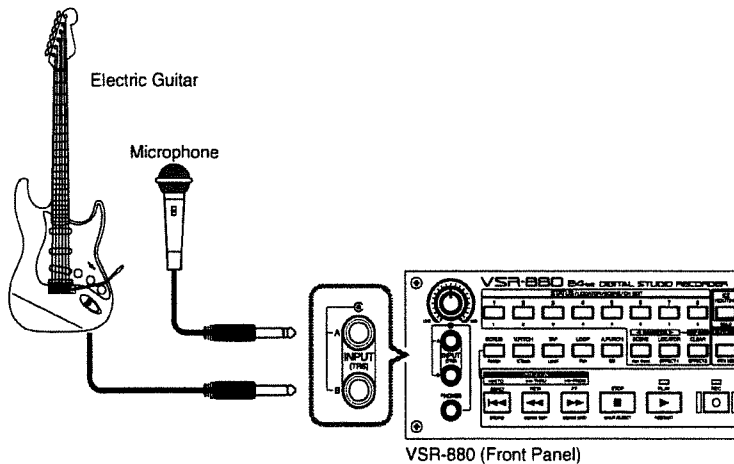

Basic Connections

■ Connecting the Roland VM-3100Pro

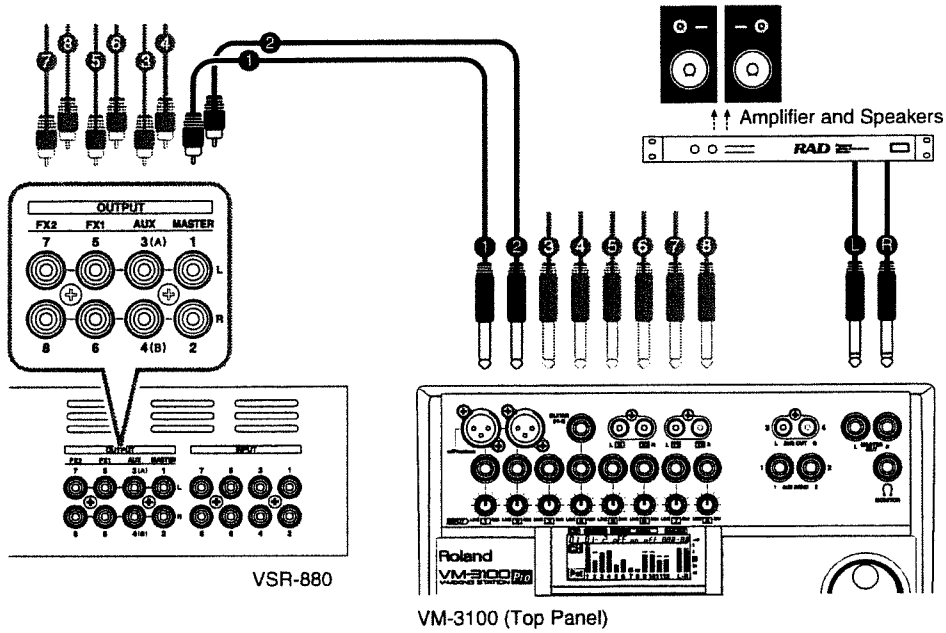

■ Connecting the Roland VM-7200/7100

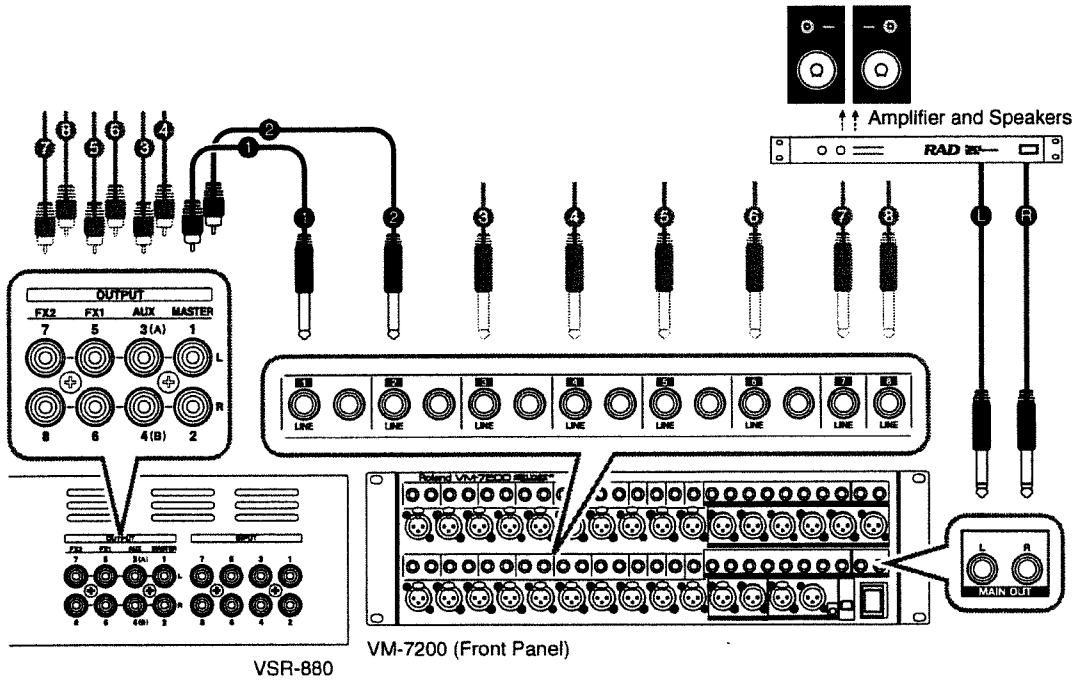

Operation From the Roland Digital Mixer

■ Connecting the Roland VM-3100Pro

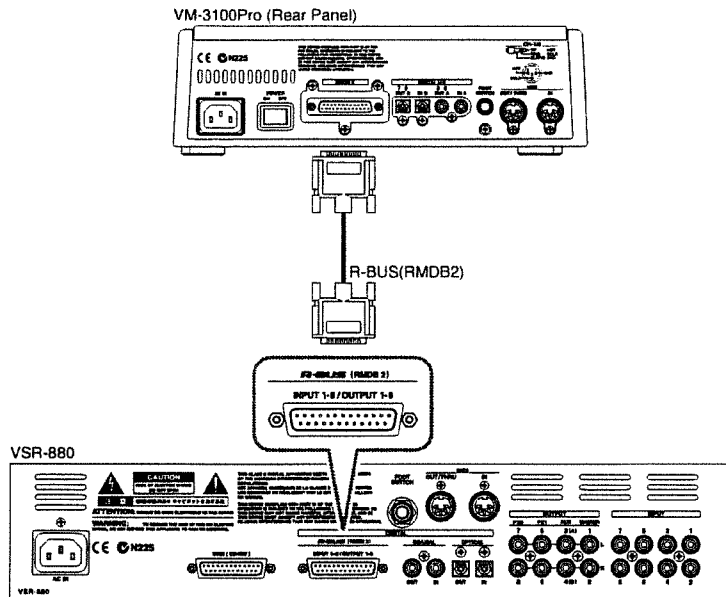

NOTE

To prevent malfunction and/or damage to speakers or other devices, always turn down the volume, and turn off the power on all devices before making any connections.



NOTE

Connect the R-BUS connector of the VSR-880 with the R-BUS device that is described in Owner's Manual only. **Be careful NOT to connect any other devices (such as RS-232C-type, parallel-type or SCSI-type devices etc.) even though that have simillar-looking connectors.**

To obtain an R-BUS cable (model: RBC-1, RBC-5), please contact your nearest Roland Service Center or authorized Roland distributor.

■ Connecting the Roland VM-7200/7100

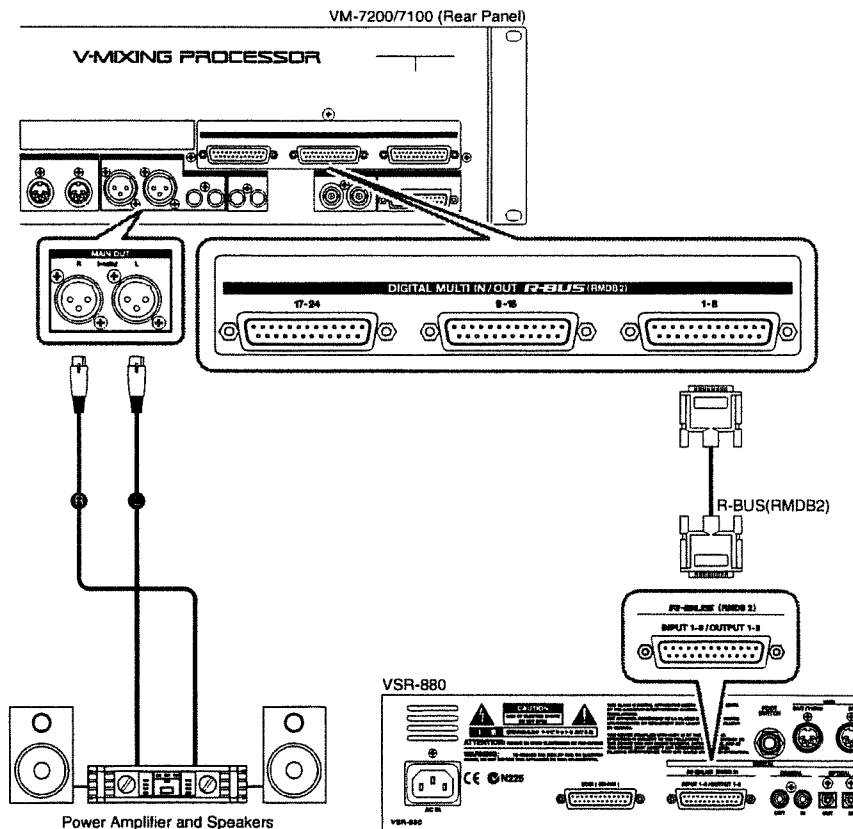

Basic Connections

Connecting the Roland DIF-AT (R-BUS)

■ Connecting the ALESIS adat

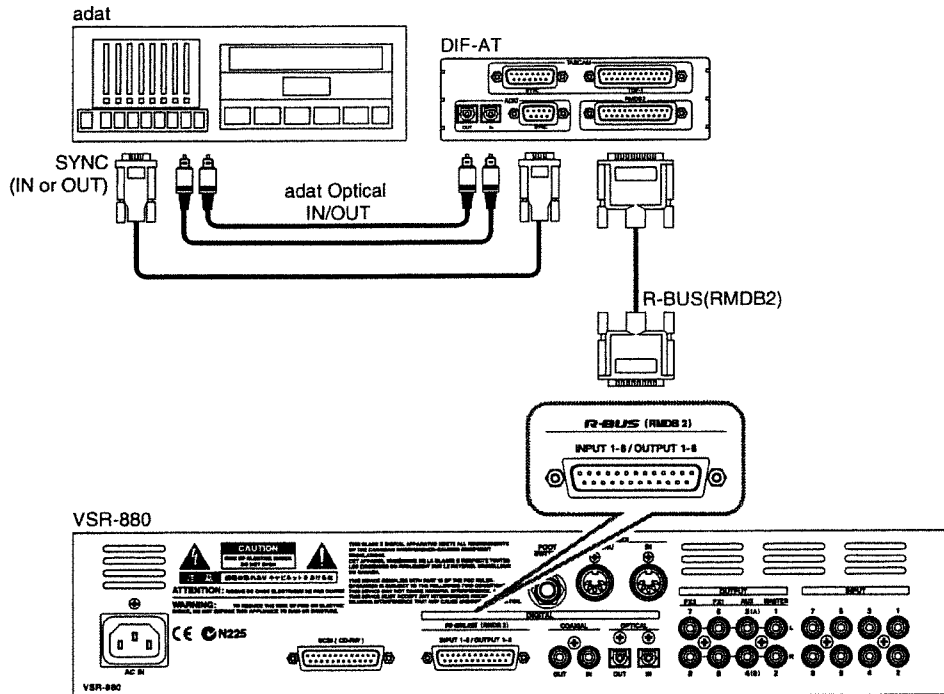

■ Connecting the TASCAM DA Series

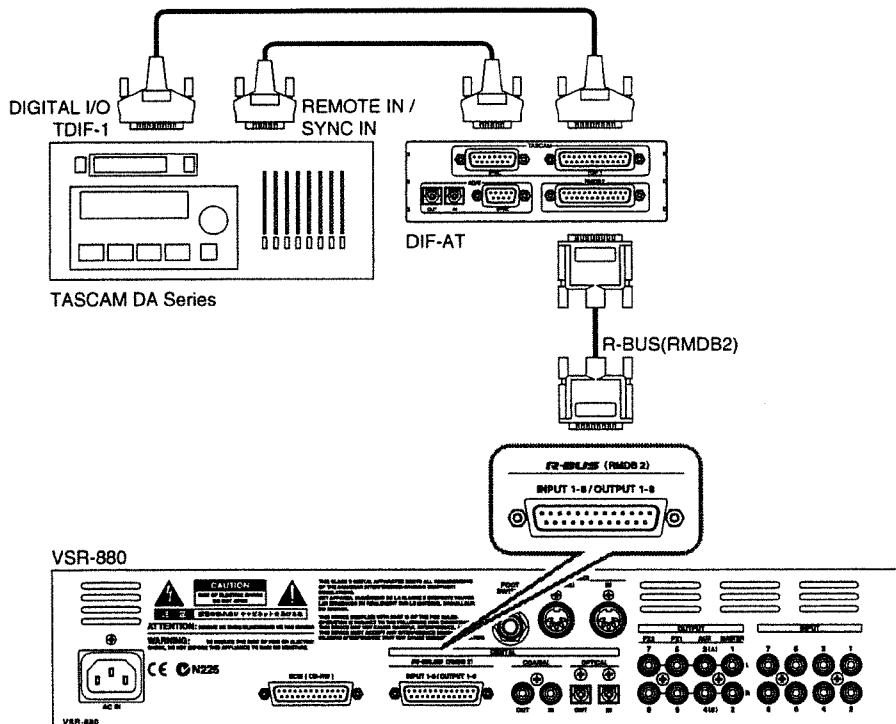

Turning On the Power

1. Turn on the power of the Roland digital mixer (e.g., VM-7000 series, VM-3100Pro) and the external devices (e.g., Alesis ADAT, TASCAM DA series).
2. Switch on the **POWER Switch** on the VSR-880.

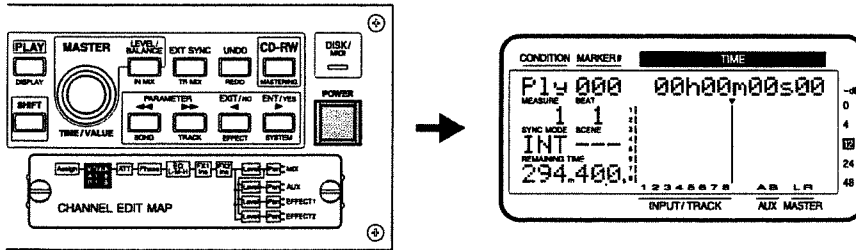

3. Turning on the power to the audio devices (power amps, monitor speakers and other devices) connected to the VSR-880.
4. Raise the volume on the audio device to a suitable level.

■ Adjusting the Display Contrast

The text or icons in the VSR-880's display may be difficult to read immediately after the unit is turned on or after it has been used for long periods, or depending on the environment in which the unit is used. If this occurs, holding down **[PLAY (DISPLAY)]** and rotating the **TIME/VALUE dial** to adjust the display contrast.

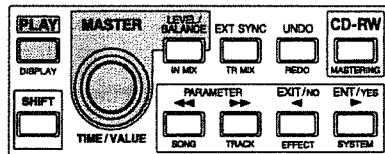

■ If You Have Trouble Understanding Displays or Operations.

If you are unfamiliar with what is displayed on a screen or find you are having difficulty understanding a certain procedure, press **[PLAY (DISPLAY)]**. This allows you to return to the screen immediately that appears when the power is turned on (PLAY condition). Thus, you can try the procedure you were working on from the beginning once more.

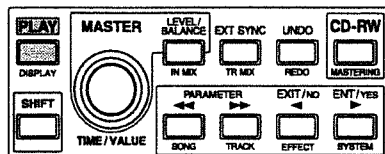

Once the connections have been completed (p. 11, 13, 14), turn on power to your various devices in the order specified. By turning on devices in the wrong order, you risk causing malfunction and/or damage to speakers and other devices.



Always make sure to have the volume level turned down before switching on power. Even with the volume all the way down, you may still hear some sound when the power is switched on, but this is normal, and does not indicate a malfunction.

Basic Connections

■ Resetting Mixer and System Settings to Their Original State

If the unit does not operate as described in the User Guide or Owner's Manual even if you have followed the procedures exactly, try resetting the state of the mixer and the system settings to an initialized condition.

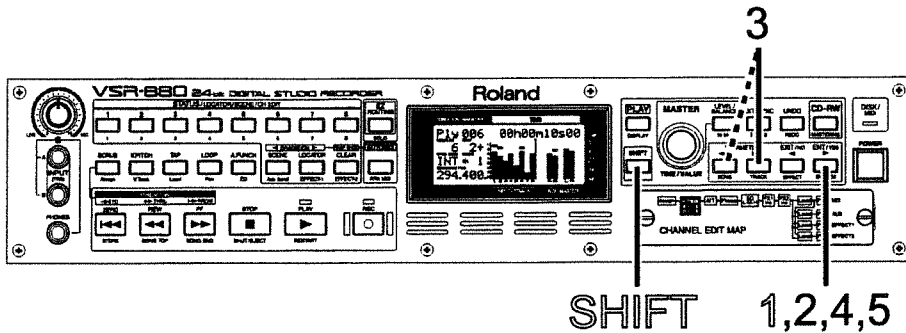

1. Press **[SHIFT] + [SYSTEM]** several times until "SYS System PRM ?" appears in the display.
2. Press **[ENT/YES]**.
3. Press **PARAMETER [▶▶]** several times until "SYS Init Mix/SysPRM ?" appears in the display.
4. Press **[ENT/YES]**. A message will ask you to confirm that you really want to restore the mixer to the initial settings.
5. Press **[ENT/YES]** again. To cancel the operation press **[EXIT/NO]**. When the mixer settings return to the initial state, you will be in Play condition.

Turning Off the Power (Shutdown)

The contents of any recorded performance will be lost if the power is suddenly cut or if you simply turn the power off. This may also result in damage to the hard disk. To safely turn off the power and be sure that your recorded performances are saved, always be sure to follow the shutdown procedure when you finish working with the VSR-880.

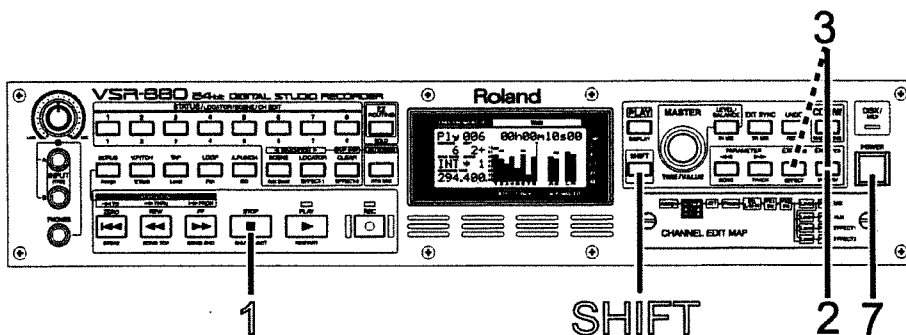

NOTE

After the power is turned off, the momentum of the hard disk causes it to continue spinning for a short while. Any physical shock to the unit during this time may damage the hard disk. Avoid moving the VSR-880 with a hard disk installed for at least 30 seconds after turning off the power.

1. Hold down [SHIFT] and press [SHUT/EJECT (STOP)]. "SHUT/EJECT?" appears in the display.

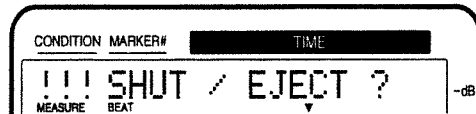

2. Press [ENT/YES]. "STORE Current?" (Save the current song?) is displayed.

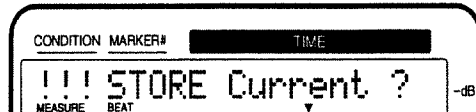

3. If you wish to save the currently selected song, press [ENT/YES]. If you do not want to save the song, press [EXIT/NO]. **If you have selected a demo song, press [EXIT/NO].**
4. When the shutdown procedure is completed properly, "PowerOFF/RESTART" appears in the display.

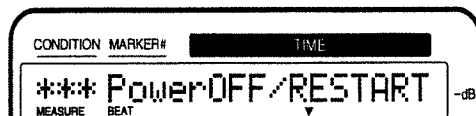

5. Turn down the volume of your audio equipment.
6. Turn off the power of the audio equipment.
7. Turn off the power of the VSR-880 with the **POWER switch** on the front panel.

■ If "STORE Current?" is Displayed.

When you begin to execute the various operations such as shutdown, the message "STORE Current?" (Save the current song?) is displayed. This message asks you whether you wish to save the currently selected song to the disk drive. If you wish to save the song before continuing with the shutdown, press [ENT/YES]. If you want to proceed with the shutdown without saving the song, press [EXIT/NO].



If you press [ENT/YES] in response to the "STORE Current?" message when Song Protect is on, or when if you have selected a demo song, the message "Song Protected" is displayed, and you will be unable to save the song. Before editing a song, set Song Protect to "Off" (p. 52). Otherwise, press [EXIT/NO].

Listening to the Demo Song

The internal hard disk contains a demo song prerecorded on it. Take a listen to the demo song before continuing.

Determining Output (Direct Out)

The VSR-880 has eight analog output jacks (OUTPUT jacks: RCA phono type). First you need to specify the output from which the sound of each track will be sent.

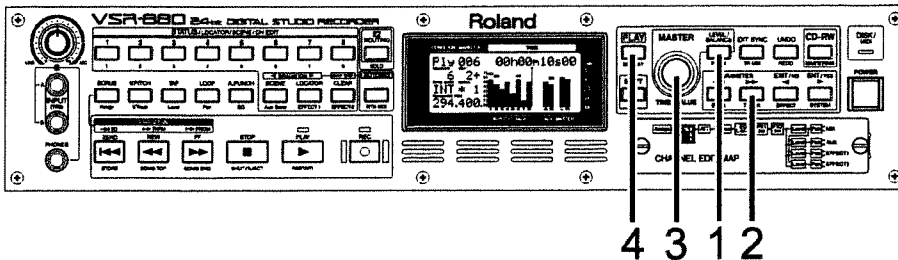

1. Press [LEVEL/BALANCE].
2. Press **PARAMETER** [▶▶] several times until "Direct Out=" appears in the display.
3. Rotate the **TIME/VALUE** dial.

Direct Out

If this is turned "On," the sound from tracks 1-8 will be output directly from the OUTPUT1-8 jacks. In this case you will be able to adjust **EQ** (equalizer). use this setting when you wish to connect the OUTPUT1-8 jacks to an external mixer and use the external mixer to adjust the level and pan of each track. With the factory settings, this is turned "On."

Track 1-8

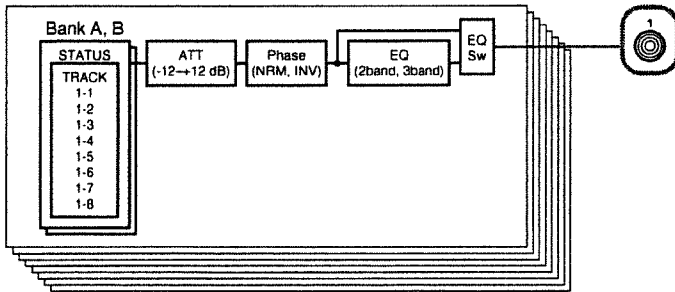

If this is turned "Off," the sound from tracks 1-8 will be sent to the MIX bus, and output from OUTPUT1-2 (MASTER). Use this setting when you wish to connect the OUTPUT1-2 (MASTER) jacks to a power amp, and use the VSR-880's internal mixer (track mixer) to adjust the level and pan of each track.

Track 1-8

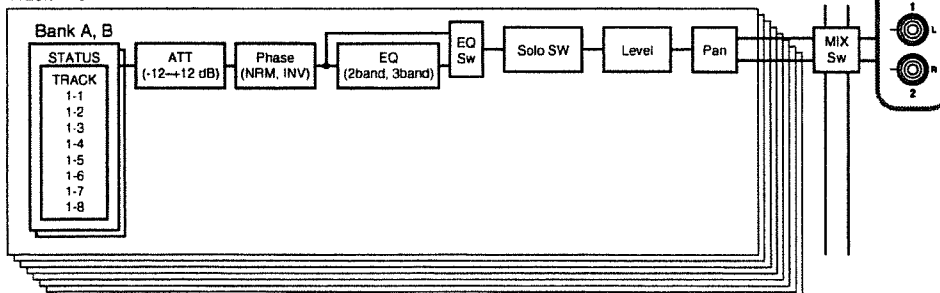

4. Press [PLAY (DISPLAY)]. Return to Play condition.



Use of the demo song supplied with this product for any purpose other than private, personal enjoyment without the permission of the copyright holder is prohibited by law. Additionally, this data must not be copied, nor used in a secondary copyrighted work without the permission of the copyright holder.

Playing Back the Demo Song

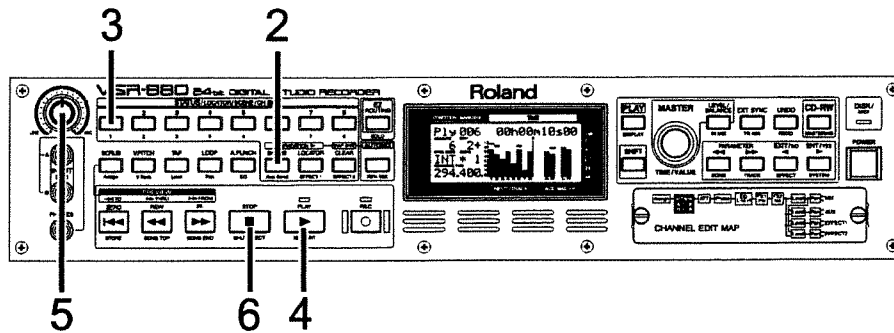

1. Turn down the volume controls of the connected external devices (mixers and amps).
2. Press **[SCENE]**. The scene indicator will light.
3. Press **SCENE [1]**.
4. Press **[PLAY]**. The demo song will playback.
5. Gradually raise the volumes of the external audio devices to adjust the volume. The playback time or level meters etc. will be displayed. To adjust the volume of the headphones, rotate the **PHONES** knob.

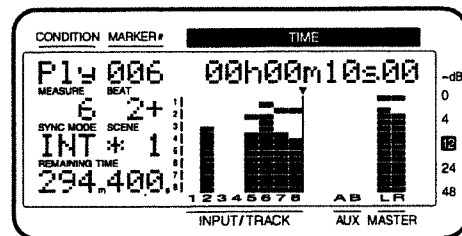

6. When playback ends, press **[STOP]**. The demo playback will stop.

■ Viewing the Level Meters and Playlists

In Play condition, you can hold down **[SHIFT]** and press **[DISPLAY (PLAY)]** to switch the contents of the level meters or playlists.

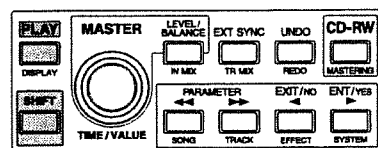

MEMO

If the **VS8F-2** is not installed (p. 7), the effect cannot be heard.

MEMO

If **Direct Out** is turned "On," changes in the volume level / pan and in the effects (send / return) will not be heard in **OUTPUT1-8**. (They can be heard in the headphones.)

Listening to the Demo Song

Pre Level

The volume level of each channel immediately after it has passed through **ATT** (attenuator) will be displayed. This means that the level meter display will not change even if you adjust the equalizer (p. 43) or the volume level (p. 21).

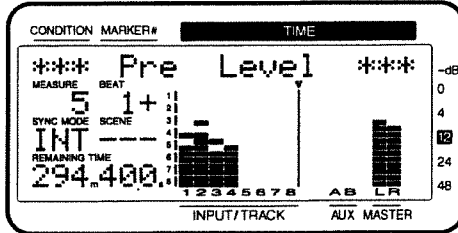

Post Level

The volume level of each channel after it has passed through **Mix Level** will be displayed. When you adjust the mix level (p. 21), the level meter display will change accordingly.

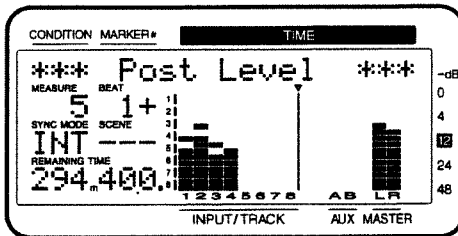

Play List

The way in which sound is recorded in the various tracks before and after the current time will be displayed.

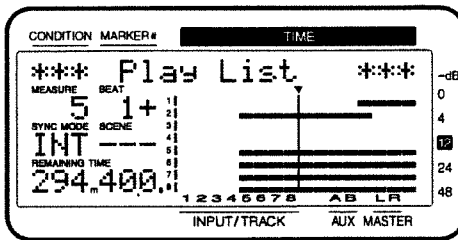

Fader/Pan

The settings of the Master Level, and the Mix Pan and the Mix Level of each channel will be displayed.

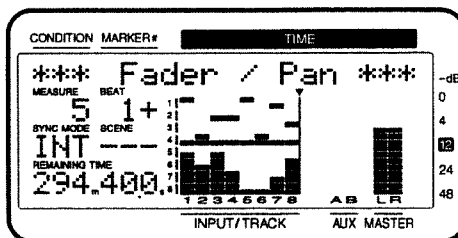

The AUX and MASTER fields indicate the respective volume levels of the signal after passing through the **AUX Level** and the **MasterLevel**.

■ Adjusting the Overall Volume

If you wish to adjust the overall volume of the demo song, you can either turn down the volume of your external audio device (e.g., power amp), or use the following procedure.

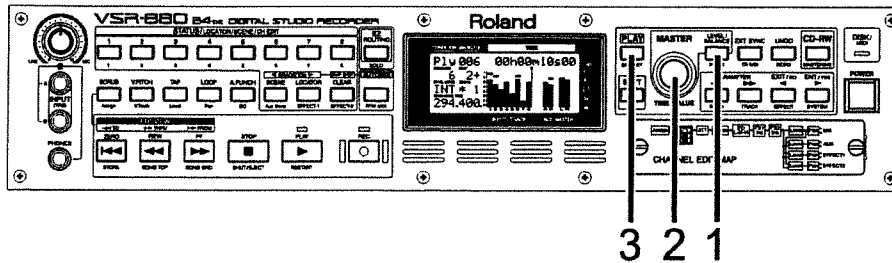

1. Press [LEVEL/BALANCE].
2. Rotate the TIME/VALUE dial to adjust the MasterLevel.

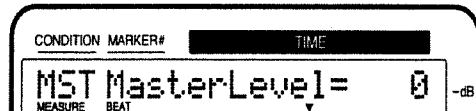

3. When you finish making adjustments, press [PLAY (DISPLAY)] to return to the Play condition.

■ Adjusting the Volume of an Individual Track

The VSR-880 does not have channel faders. If you wish to independently adjust the volume of each track, you can either turn down the volume control of your external audio device (e.g., mixer) for the corresponding track, or use the following procedure.

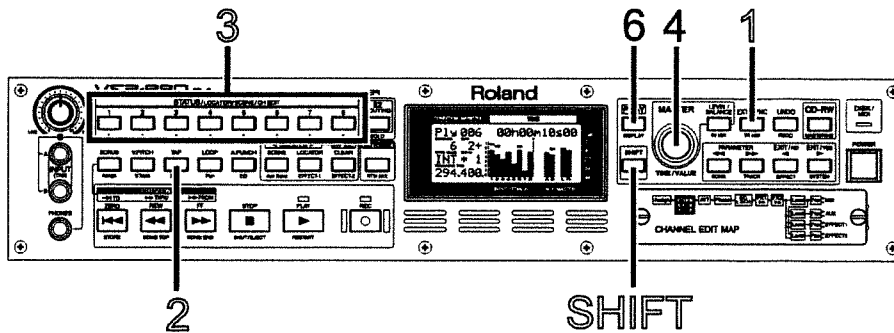

1. Hold down [SHIFT] and press [TR MIX(EXT SYNC)].
2. Hold down [SHIFT] and press [Level(TAP)].
3. Hold down [SHIFT] and press CH EDIT ([1]-[8]) button for the track whose volume you wish to adjust.
4. Rotate the TIME/VALUE dial to adjust the Mix Level.
5. Repeat steps 3-4 as necessary.
6. When you finish making adjustments, press [PLAY (DISPLAY)] to return to the Play condition.

MEMO

At this time you can adjust the track mixer.

Listening to the Demo Song

■ Adjusting the Headphone Volume

If you wish to adjust the volume of the headphones, make sure that the **MasterLevel** (master level: p. 21) is raised, and adjust the **PHONES** knob.

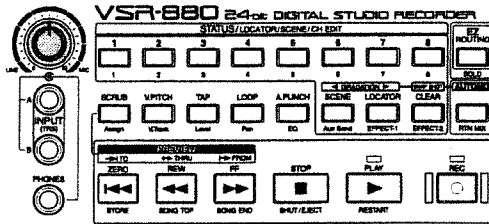

With the factory settings, the headphones will output the same sound as the MIX bus.

Listening to the Demo Song with a Different Arrangement (Scene)

The demo song contains several completely different sets of settings for pan, playback track, and effects etc. These settings are collectively called a **scene**. By recalling different scenes or changing the scene while you playback a demo song, you can hear the demo song arranged in different ways.



Please stop playback before you switch scenes.

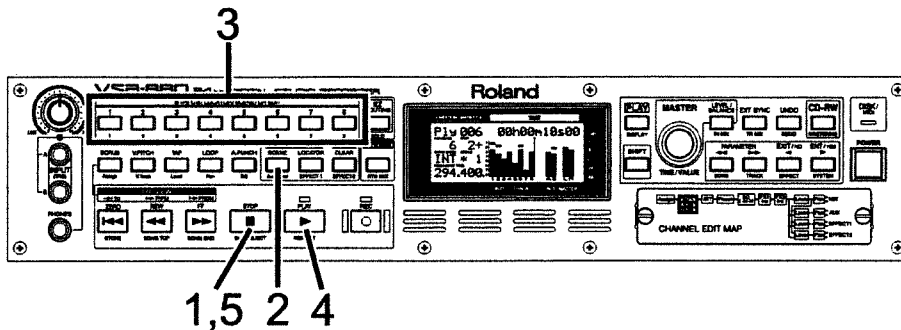

If **Direct Out** is turned "On," changes in the volume level / pan and in the effects (send / return) will not be heard in OUTPUT1-8. (They can be heard in the headphones.)

1. Press [STOP].
2. Press [SCENE]. The scene indicator will light.
3. Of the **SCENE** ([1]-[8]) buttons, select and press a button whose indicator is lit. For example if you wish to recall scene 2, press [2].
4. Wait for the **SCENE** indicator to go dark, and press [PLAY].
5. Press [STOP]. Playback will stop.
6. Repeat steps 2-5 to hear and compare various arrangements of the demo song.



If the **VS8F-2** is not installed (p. 7), the effect cannot be heard.

Preparations for multi-track recording

This chapter explains the basic procedure for recording on the VSR-880. Please follow through these steps to understand the procedure.

Regarding Hard Disk Partition Size

When purchased, the hard disk is divided (partitioned) into 1,000 MB units.

If you are using a hard disk that is 2100 MB or larger, the VS-1680 demo song "SEEMS SO RIGHT" will also be saved, but this cannot be played back by the VSR-880. The total size of these demo songs is approximately 490 MB, so the space that can actually be used is approximately 510 MB.

If you wish to record for a longer time, you can switch the partition (e.g., IDE:0 → IDE:1). If you are using a 2100 MB or larger hard disk, switch partitions before you continue with the operations of this chapter (multitrack recording) so that you will have a longer recording time available (p. 105).

If you wish to completely delete "SEEMS SO RIGHT" from the hard disk to increase the available space, you can initialize the hard disk (p. 106). At this time, all songs that are saved on the hard disk (including the VS-880 demo song) will be erased, and cannot be recovered. As necessary, back up the songs to a CD-RW disc (p. 96).

Creating a New Song (Song New)

Recording operations cannot be performed when the demo song is selected. This is because the demo song is protected so that its contents cannot be modified (Song Protect; p. 51). In order to record, use the following procedure to prepare a new song. This is analogous to putting a new tape into a tape-type multi-track recorder.

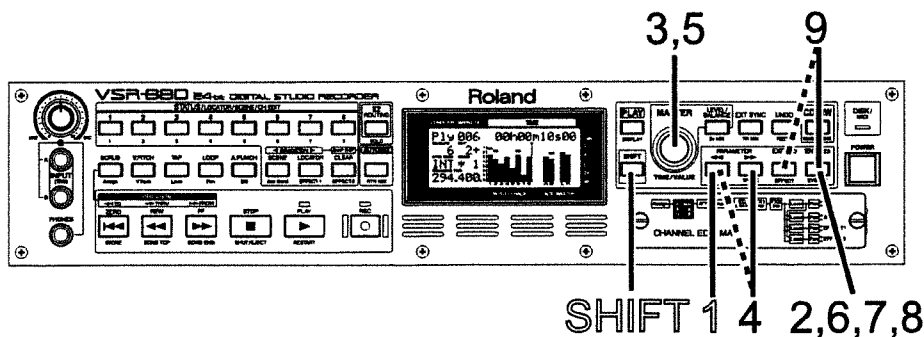

1. Press **[SHIFT] + [SONG (◀◀)]** several times until "SNG Song New ?" appears in the display.
2. Press **[ENT/YES]**.
3. "SNG SampleRate=" appears in the display. Use the **TIME/VALUE dial** to select the sample rate. **If you will be creating an original audio CD, choose "44.1 kHz."**

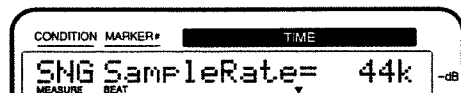

Sample Rate

Select a sample rate (32.0 kHz, 44.1 kHz, or 48.0 kHz). You cannot change the sample rate after the song is recorded. In addition, you cannot mix different sample rates in the same song.



When the Sample Rate is selected to "48 kHz," up to 6 tracks can be recorded simultaneously. Up to 8 tracks can be played back simultaneously.

Preparations for multi-track recording

- Press **PARAMETER** [▶▶].
- Use the **TIME/VALUE** dial to select the Recording Mode (VSR, CDR, MAS, MT1, MT2, LIV). **For the highest recording quality, use the “MTP” recording mode.**



Record Mode

Select the sound's quality and time based on the recorded contents. Once a song is recorded, these settings cannot be changed.

- VSR:** Compatible with professional-quality equipment (digital mixers, digital effects, processors, etc.). The high-quality sound can be worked with — recorded and edited — as is, with no loss of sonic quality when played back or output.
 - CDR:** This format allows you to omit the step of conversion to an image file when creating an audio CD (p. 91). **When this mode is selected, the unit will function as a four-pair stereo recorder (Channel Link on: tracks a–d).**
 - MAS:** With this setting, you can get the high-quality sounds compatible to that's quality of CD player or DAT recorder.
 - MT1:** While maintaining high-quality sound, recording time is approximately twice that available in “MAS” mode. This mode is good when doing a lot of track bouncing.
 - MT2:** While maintaining high-quality sound, recording time is longer than that available in “MT1” mode. This mode is good for normal operations.
 - LIV:** Recording time is longer than with “MT2” mode. This mode is appropriate when your hard disk lacks much free space or when recording live performances.
- Press **[ENT/YES]**. “Create NewSong?” appears in the display.
 - Press **[ENT/YES]** again. “Create New - Sure?” appears in the display.
 - Press **[ENT/YES]** again. “STORE Current?” appears in the display.
 - If you wish to save the current song, press **[ENT/YES]**; if not, press **[EXIT/NO]**. **If you have selected a demo song, then press [EXIT/NO].**
- 10.** When a new song has been created, you will return to Play condition. The newly created song will be selected as the song for recording/playback.

About Recording Time

The recording time (track minutes) of both sampling rate and recording mode are as shown below (for 1 track, with 3.2 GB hard disk, 1 GB x 3 partitions, unit:minutes).

Recording Mode	Sample Rate		
	48.0 kHz	44.1 kHz	32.0 kHz
VSR	371 + 371 + 371	404 + 404 + 404	557 + 557 + 557
CDR	185 + 185 + 185	202 + 202 + 202	278 + 278 + 278
MAS	185 + 185 + 185	202 + 202 + 202	278 + 278 + 278
MT1	371 + 371 + 371	404 + 404 + 404	557 + 557 + 557
MT2	495 + 495 + 495	539 + 539 + 539	742 + 742 + 742
LIV	594 + 594 + 594	646 + 646 + 646	891 + 891 + 891



The contents of the demo songs are protected from being changed or overwritten (Song Protect; (p. 51)). You cannot record, edit, save, or other such operations with the demo song. This means if you press **[ENT/YES]** at Step 9 when a demo song is selected, the message “Song Protected” will appear, and the procedure cannot be continued.



The chart is a general yardstick for estimating recording times. Actual times may be somewhat shorter depending on your hard disk's specifications or the number of songs created.

■ If “Drive Busy!” is Displayed

If this message appears during recording or playback, it means that the disk drive cannot catch up with the data read/write speed. In such instances, create a new song which lower the sample rate or recording mode from their current settings, and record over.

■ Song Numbers

On the VSR-880, management of song data is accomplished by assigning a song number to every song that is saved. Newly created songs are given the lowest currently available number. For example, if all numbers up to song number 5 are already assigned, then the number 6 is taken by the new song.

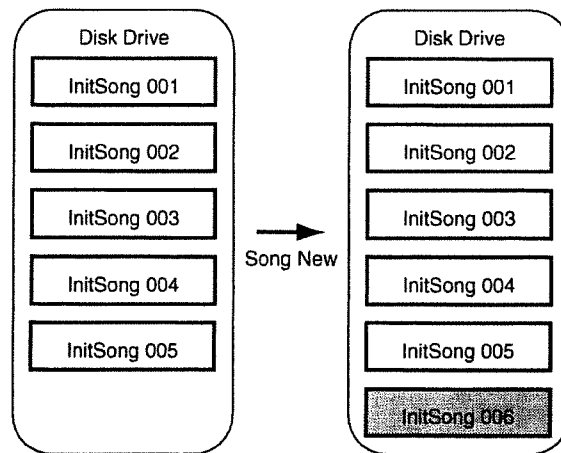

Furthermore, even if song numbers up to 5 are occupied, if Song 3 is deleted, then the new song is given that now lowest vacant number.

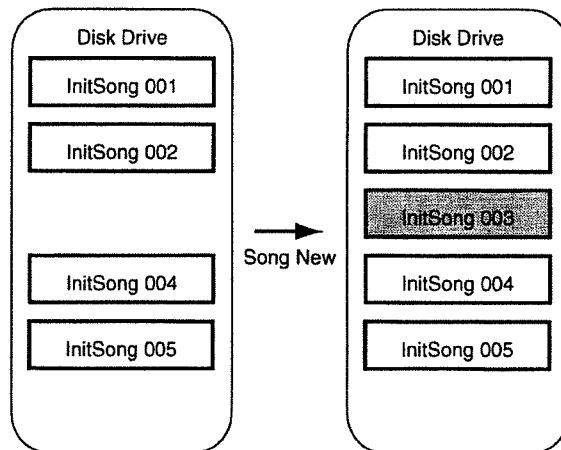

Preparations for multi-track recording

Selecting a Song (Song Select)

If the VSR-880 contains multiple songs, use the following procedure to select a song.

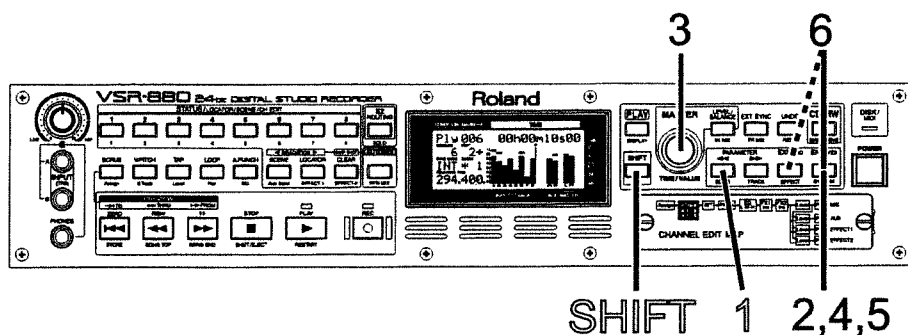

1. Press **[SHIFT] + [SONG (◀)]** several times until “SNG Song Select ?” appears in the display.
2. Press **[ENT/YES]**.
3. Use the **TIME/VALUE** dial to appear the song name that you wish to select. An asterisk “*” will be displayed at the beginning of the current song.

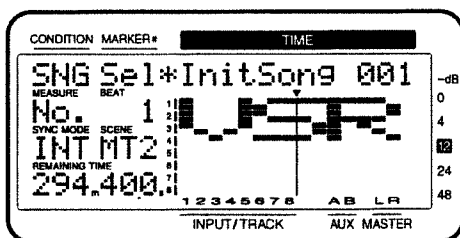

Different types of songs (for the VS-880, VS-880EX, VS-1680 and VSR-880) are distinguished.

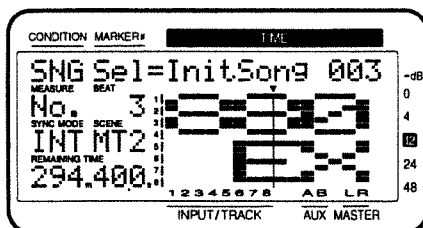
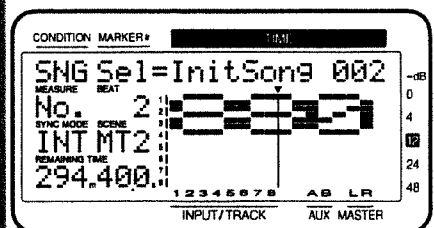

4. Press **[ENT/YES]** again. “Select Song, Sure?” (Are you sure that you want to select this song?) will be displayed.
5. Press **[ENT/YES]** again. “STORE Current?” (Store the current song?) will be displayed.
6. If you wish to save the current song, press **[ENT/YES]**. If not, press **[EXIT/NO]**. If you have selected a demo song, then press **[EXIT/NO]**.
7. The song will be selected, and you will return to the Play Condition.

Changing the Name of the Song (Song Name)

When you create a song, it will automatically be given a name like "InitSong001." However this makes it difficult to remember what song it is. We recommend that you assign a unique name to your song so that data management will be easier.

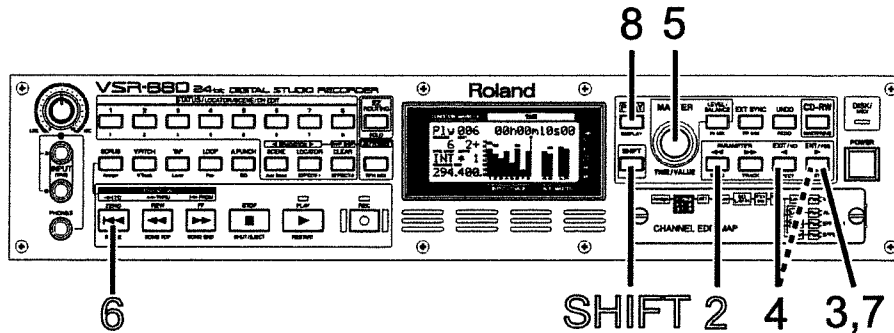

1. Make the song whose name you want to change the current song.
2. Press **[SHIFT] + [SONG (◀)]** several times until "SNG Song Name/ Prtct?" appears in the display.
3. Press **[ENT/YES]**. The name of the song (Song Name) appears in the display.

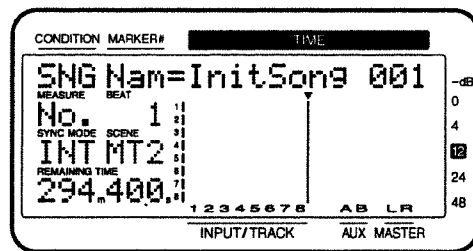

4. Move the cursor so that the character that you wish to modify will blink. Press **[◀]** or **[▶]**.
5. Modify the character. Rotate the **TIME/VALUE dial**. By holding down **[SHIFT]** as you rotate the **TIME/VALUE dial** you can make the characters change more rapidly.
6. When you have finished writing the song name or comments, hold down **[SHIFT]** and press **[STORE (ZERO)]**. "STORE OK ?" appears in the display.
7. Press **[ENT/YES]**. The song is saved.
8. Press **[PLAY (DISP)]**. Return to Play condition.

Making a Multi-Track Recording 1 (Using Front Panel)

We will explain how to operate the front panel buttons and knobs to perform multitrack recording of electronic musical instruments such as keyboards.

Adjusting the Input Sensitivity

If you can adjust the volume of the recording source (mixer or electronic musical instrument) connected to the VSR-880, you should adjust the volume of the recording source to set the recording sensitivity. If you cannot adjust the volume on the recording source, or if you wish to make fine adjustments to the recording sensitivity, use the following procedure.

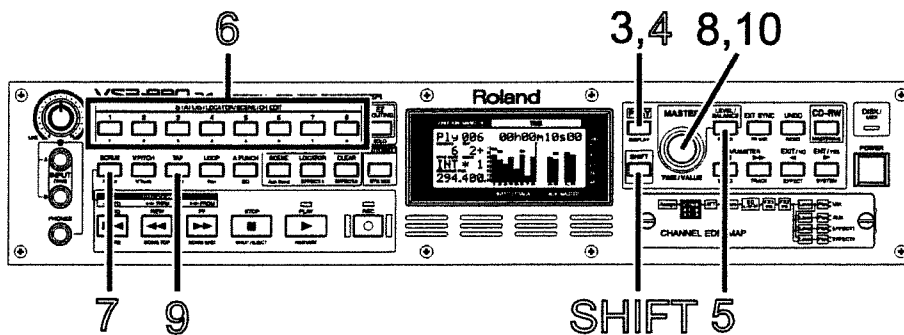

1. Lower the volume of your audio equipment (mixers, power amps or others) that is connected to VSR-880.
2. Connect the instruments to the INPUT jacks (1-8) of the rear panel.

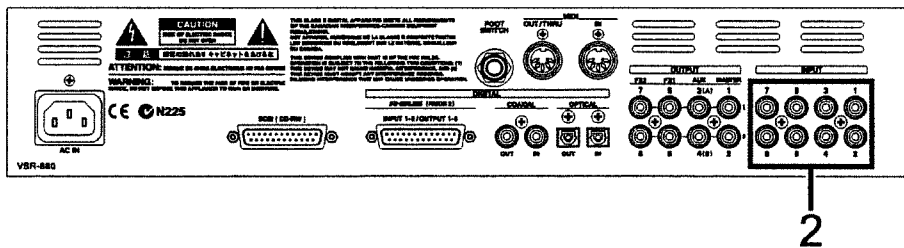

3. Press [PLAY (DISPLAY)].
4. Press [SHIFT] + [PLAY (DISPLAY)] until "Pre Level" appears in the display. At this time, the volume level (pre level) immediately after ATT (attenuator) will be displayed.

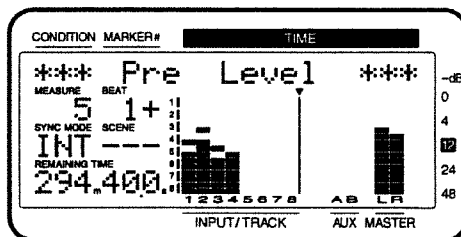

5. Press [SHIFT] + [IN MIX (LEVEL/BALANCE)].



At this time you can adjust the input mixer.

Making a Multi-Track Recording 1 (Using Front Panel)

Recording On a Track

This section explains the procedure for using a keyboard connected to the INPUT 1 jack to record performance to track 1.

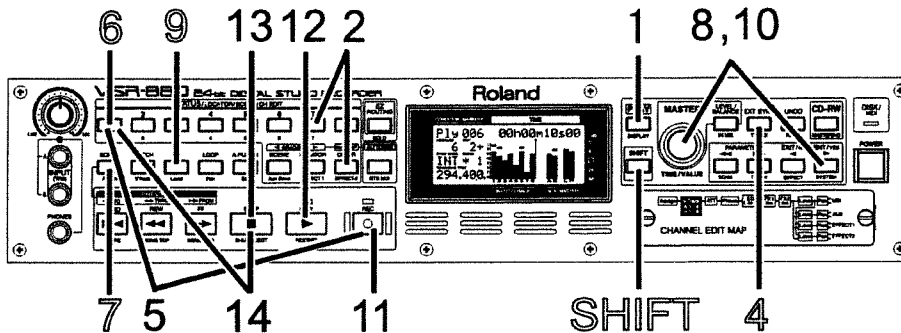

1. Press **[PLAY (DISPLAY)]**.
2. Hold down **STATUS** ([1]–[8]; any track is OK) and press **[CLEAR]**. This will clear any existing input and/or track routing assignments.
3. Make fine adjustments to the recording level as described in “Adjusting the input sensitivity” (p. 28).
4. Press **[SHIFT] + [TR MIX (EXT SYNC)]**. (Track Mixer)
5. Select the recording track. Hold down **[REC]** and press **STATUS** ([1]–[8]) of the desired track. For this example, hold down **[REC]** and press **[1]**. The STATUS indicator will blink red. (ready to record)
6. Hold down **[SHIFT]** and press **STATUS** ([1]–[8]) of the desired track. For this example, hold down **[SHIFT]** and press **[1]**.
7. Press **[SHIFT] + [Assign (SCRUB)]**.
8. Select the source that will be recorded to the track. Use the **TIME/VALUE dial** to select the source you wish to record, and press **[ENT/YES]**. For this example, we will be recording the keyboard connected to INPUT1, so select “IN1” and press **[ENT/YES]**.

MEMO

At this time, the sound of input channel 1 will no longer be output directly from master out.

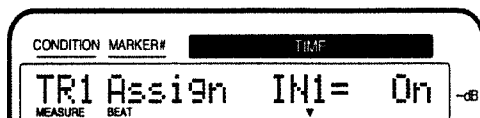

Assign ***

Specify the source/track/effect return which will assigned to each track for recording. If you press **[ENT/YES]** the display will indicate “On,” showing that it has been assigned for recording. If you press **[EXIT/NO]**, the display will indicate “Off,” and the signal will not be assigned (it will not be recorded).

The symbols displayed in “****” indicate the following signals.

- IN1–IN8: INPUT Jack 1–INPUT Jack 8 (FRONT/REAR/DIGITAL/R-BUS)
- TR1–TR8: Track 1–Track 8 (Track Bouncing/Mixdown)
- FX1: Effect 1 Return
- FX2: Effect 2 Return
- StIn: Stereo In

For example, a display of “TR1 Assign IN1= On” indicates that “the source from INPUT jack 1 has been assigned to track 1 for recording.”

Making a Multi-Track Recording 1 (Using Front Panel)

If you continue holding **STATUS** ([1]–[8]); any track is OK) for a short time longer, you can check which source is assigned to each track.

Assigned sources 1–8 (upper line)
Assigned tracks 1–8 (lower line)

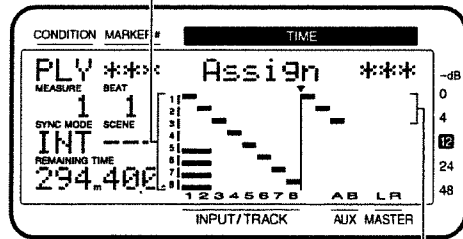

Recording Tracks (1–8)

Stereo In (first line)
Effect 1 (second line)
Effect 2 (third line)

9. Press **[SHIFT] + [Level (TAP)]**.
10. Rotate the **TIME/VALUE** dial to verify that the volume changes. The track mixer **Mix Level** is used for monitoring. It does not affect the recording level. Even if you hear no sound, you can still record. Adjust the volume to a suitable level for listening.
11. Press **[REC]**. The REC indicator will blink red.
12. Press **[PLAY]**. The PLAY indicator will light green, and recording will begin. Start playing your instruments.
13. When you finish playing, press **[STOP]**.
14. Hold down **[STOP]**, and press the **STATUS** ([1]–[8]) button of the track that you recorded. For this example, hold down **[STOP]** and press **[1]**. STATUS indicator will light green. (ready to play back)

MEMO

At this time, the sound of input channel 1 will be output directly from master out.

Making a Multi-Track Recording 1 (Using Front Panel)

Playing Back the Performance You Recorded

Now let's playback the performance that was recorded on track 1.

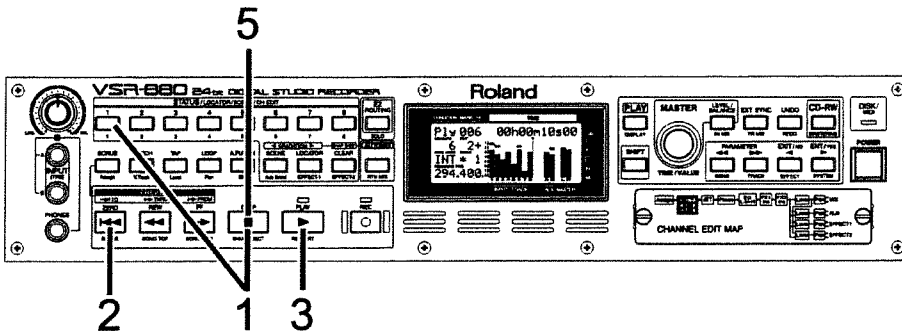

1. Select the track(s) for playing back. Hold down **[STOP]** and press **STATUS** (**[1]–[8]**) of the track(s) that you wish to play back. For this example, hold down **[STOP]** and press **[1]**.
2. Press **[ZERO]**. You will return to the beginning of the song.
3. Press **[PLAY]**. The song will play back.
4. Adjust the volume of track 1.
 - 4-1. Press **[SHIFT] + [TR MIX (EXT SYNC)]**. (Track Mixer)
 - 4-2. Press **[SHIFT] + [1]**.
 - 4-3. Press **[SHIFT] + [Level (TAP)]**.
 - 4-4. Rotate the **TIME/VALUE dial** to adjust the volume to a comfortable level.
5. When playback ends, press **[STOP]**.

Recording on V-Track

The VSR-880 features 8 tracks, each of which contains 8 auxiliary tracks. These subsidiary tracks are referred to as **V-tracks**. Each song can have two sets (A and B) of these 64 V-tracks (8 tracks x 8 V-tracks), and each such set is referred to as a **V-track bank**. By using all of these tracks to their full potential, you can create recordings of up to 128 (64 (V-track) x 2 (V-track bank)) tracks. For actual recording/playback, you specify the bank that you wish to use, and then select one of the V-tracks.

The following example shows how to record a performance on V-track 2 of track 1.

■ Switching V-Tracks

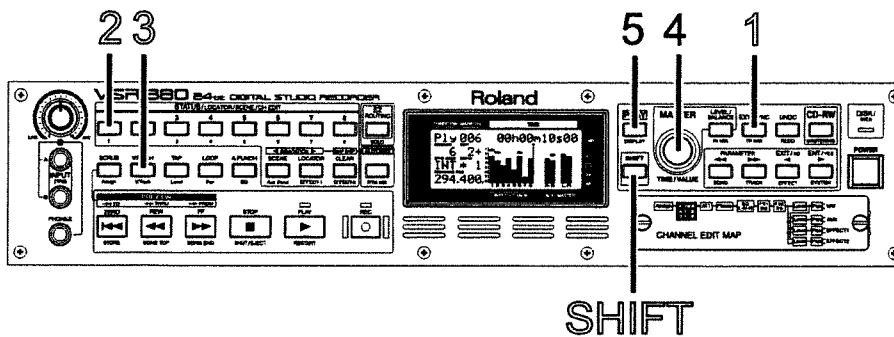

1. Press **[SHIFT] + [TR MIX (EXT SYNC)]**. (Track Mixer)
2. With song playback stopped, press channel **[SHIFT] + [1]**. The upper left of the display will indicate "TR1," allowing you to make settings for track 1.
3. Press **[SHIFT] + [V.Track (V.PITCH)]**. The upper line of the display will indicate "V.Track=," allowing you to select the V-track.

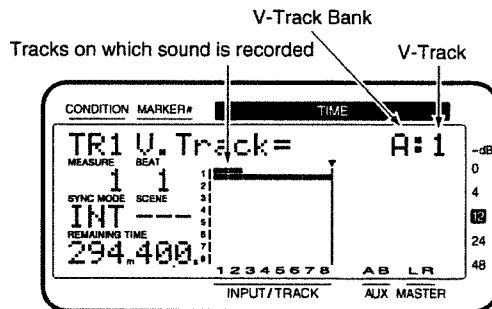

A displayed on the upper line of the V-track number indicates that sound has been recorded in that V-track. In the above display, sound has been recorded in V-Tracks 1 of Tracks 1 and 2.

A displayed on the lower line of the V-track number indicates that V-track is selected. In the above display, V-track 1 is selected for all tracks 1–8.

Making a Multi-Track Recording 1 (Using Front Panel)

- Use the **TIME/VALUE dial** to select the V-track for recording or playback. Here, select "A:2."

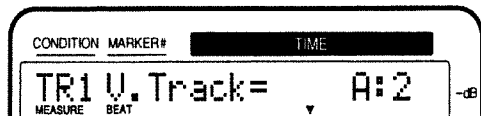

- Press **[PLAY (DISPLAY)]**. Return to Play condition.
- Now you will be able to record on V-track 2 of track 1. As described in "Recording On a Track" (p. 30), record your performance and listen to it.

■ Comparing the Recorded Content of Two V-Tracks

If you have been following the procedures in the previous examples, V-tracks 1 and 2 of track 1 contain recorded performances. Here's how you can compare the performances of the two V-tracks.

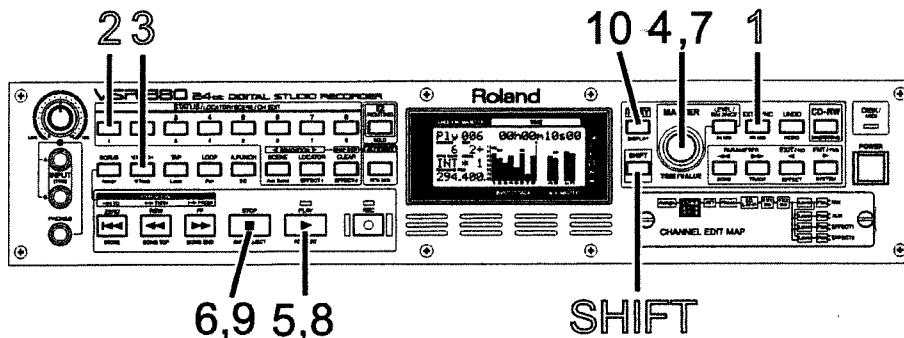

- Press **[SHIFT] + [TR MIX (EXT SYNC)]**. (Track Mixer).
- With song playback stopped, press channel **[SHIFT] + [1]**. The upper left of the display will indicate "TR1," allowing you to make settings for track 1.
- Press **[SHIFT] + [V.Track (V.PITCH)]**. The upper line of the display will indicate "V.Track=," allowing you to select the V-track.
- Use the **TIME/VALUE dial** to select the V-track for recording or playback.

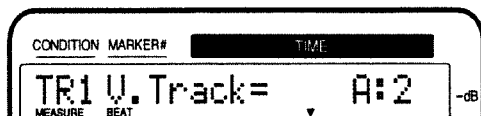

- Press **[PLAY]**. The song will play back.
- Press **[STOP]**.
- Use the **TIME/VALUE dial** to switch V-tracks
- Press **[PLAY]**. Notice that a different performance is played back.
- Press **[STOP]**.
- Press **[PLAY (DISPLAY)]**. Return to Play condition.

Making a Multi-Track Recording 1 (Using Front Panel)

■ Switching V-Track Bank

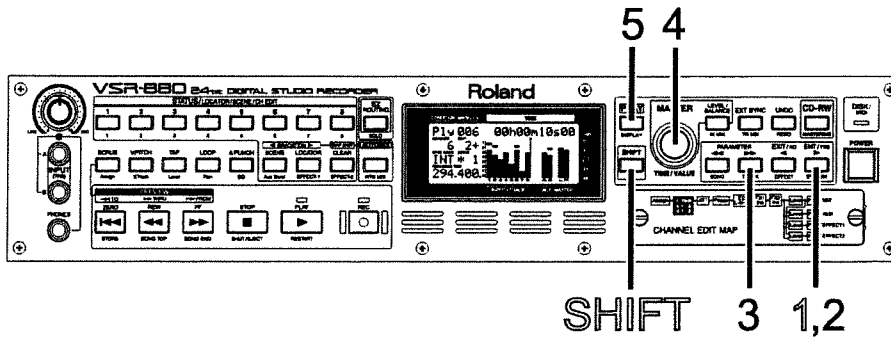

1. Press **[SHIFT] + [SYSTEM (▶)]** several times until "SYS System PRM ?" appears in the display.
2. Press **[ENT/YES]**.
3. Press **PARAMETER [▶]** several times until "V-Track Bank =" appears in the display.
4. Rotate the **TIME/VALUE dial** to select "A" or "B."
5. Press **[PLAY (DISPLAY)]**. Return to Play condition.

MEMO

V-tracks within the different V-track bank cannot be recorded or played back simultaneously.

Making a Multi-Track Recording 1 (Using Front Panel)

Recording On Other Tracks (Overdubbing)

The VSR-880 allows you to record new performances on other tracks while you listen to the playback of previously recorded tracks. This process is called **Overdubbing**. Here we will explain how you can re-connect the keyboard to the INPUT2 jack and record it on track 3 while listening to the keyboard performance that you recorded earlier on track 1. Before you continue, adjust the input sensitivity of the keyboard that has been re-connected to INPUT jack 2, as described in "Adjusting the input sensitivity" (p. 28).

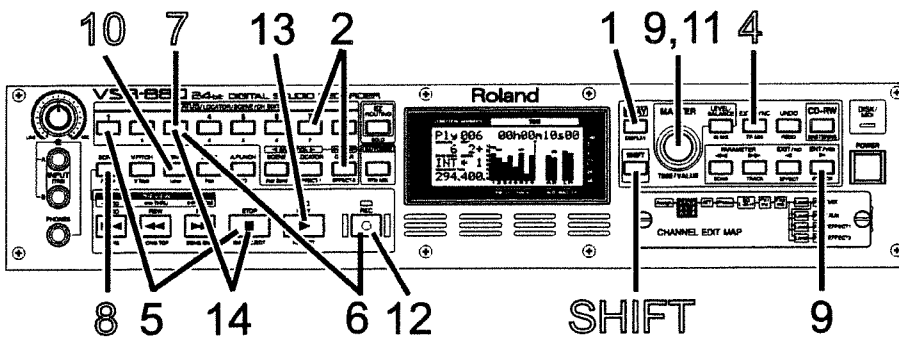

1. Press **[PLAY (DISPLAY)]**.
2. Hold down **STATUS** ([1]-[8]:any track is OK) and press **[CLEAR]**. The assignments of input sources to tracks will be cleared.
3. Make fine adjustments to the recording level as described in "Adjusting the input sensitivity" (p. 28).
4. Press **[SHIFT] + [TR MIX (EXT SYNC)]**. (Track Mixer)
5. Select the playback track(s). Hold down **[STOP]**, and press **STATUS** ([1]-[8]) of the track(s) that you wish to hear. For this example, hold down **[STOP]** and press **[1]**. The STATUS indicator will light green. (ready to play back)
6. Select the track(s) for recording. Hold down **[REC]** and press **STATUS** ([1]-[8]) of the track(s) that you wish to record. For this example, hold down **[REC]** and press **[3]**. The STATUS indicator will blink red. (ready to record)
7. Hold down **[SHIFT]** and press **STATUS** ([1]-[8]) of the track(s) that you wish to record. For this example, hold down **[SHIFT]** and press **[3]**.
8. Press **[SHIFT] + [Assign (SCRUB)]**.
9. Select the source that you will record on the track. Use the **TIME/VALUE dial** to select the source for recording, and press **[ENT/YES]**. For this example we will be recording the keyboard that is connected to INPUT2, so select "IN2" and press **[ENT/YES]**.

MEMO

At this time, the sound of input channel 2 will no longer be output directly from master out.

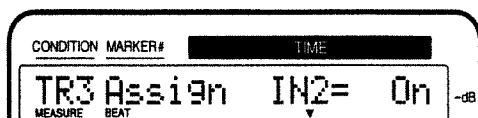

Making a Multi-Track Recording 1 (Using Front Panel)

If you continue holding **STATUS** ([1]–[8]); any track is OK for a short time longer, you can check which source is assigned to each track.

Assigned sources 1–8 (upper line)
Assigned tracks 1–8 (lower line)

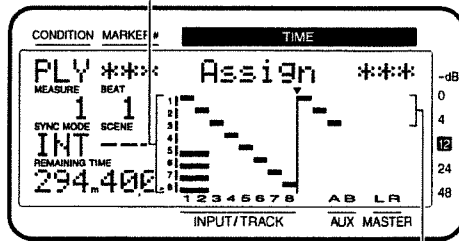

Recording Tracks (1–8)

Stereo In (first line)
Effect 1 (second line)
Effect 2 (third line)

10. Press **[SHIFT] + [Level (TAP)]**.
11. Rotate the **TIME/VALUE** dial to verify that the volume changes. The track mixer **Mix Level** is used for monitoring. It does not affect the recording level. Even if you hear no sound, you can still record. Adjust the volume to a suitable level for listening.
12. Press **[REC]**. The REC indicator will blink red.
13. Press **[PLAY]**. The PLAY indicator will light green, and recording will begin. Start playing your keyboard.
14. When you finish playing and recording, press **[STOP]**.
15. Hold down **[STOP]**, and press the **STATUS** ([1]–[8]) button for the track that was recorded. For this example, hold down **[STOP]** and press **[3]**. STATUS indicator will light green. (ready to play back)

Making a Multi-Track Recording 1 (Using Front Panel)

Recording Digital Signals

With the VSR-880, you can record the digital signals output by CD players, DAT and MD recorders, Roland VS-1680, and other digital audio devices as is.

■ Items Necessary for Digital Recording

- VSR-880EX (1)
- CD player, DAT and MD recorder, or other digital audio device or devices
- Digital connector cable (coaxial or optical)

■ Make the Digital Connections

Connect the digital output connector of your audio device with the VSR-880's DIGITAL IN connector. DIGITAL IN1 is a coaxial connector, DIGITAL IN2 an optical connector. Use the appropriate connector for your audio device.

■ Match the Sample Rates

It can record the digital signals when the sample rate of the song is set to match the sample rate of the input source.

The song created when a disk drive is initialized will have a sample rate of 44.1 kHz. If the sample rate of the input source is other than 44.1 kHz, create a new song with that sample rate (p. 23). Then, if you wish to create original audio CDs, select that sample rate for 44.1 kHz (p. 23).

■ In Order to Make a Digital Connection with Your CD Player

At the time of purchase, the VSR-880 is not able to record the output of CD players via its DIGITAL IN connectors. Perform the following procedure when you wish to make a digital connection with your CD player.

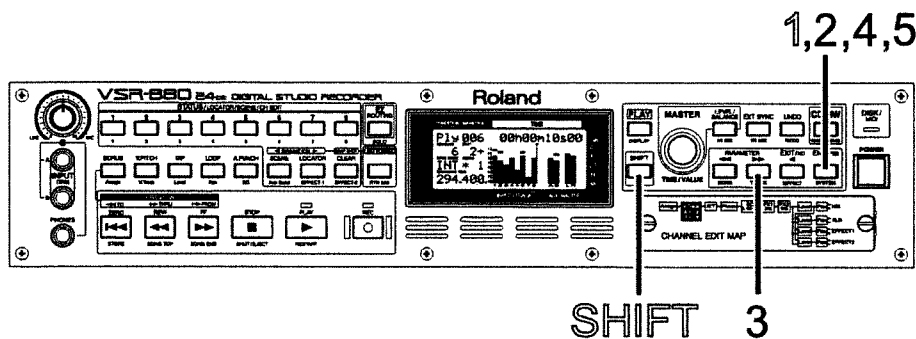

1. Press [SHIFT] + [SYSTEM (▶)] several times until "System PRM ?" appears in the display.
2. Press [ENT/YES].
3. Press PARAMETER [▶▶] several times until "CD DigiREC → On ?" appears in the display.
4. Press [ENT/YES]. "Obey Copyrights?" appears in the display.



The VSR-880's digital interface conforms to S/P DIF. When recording digital signals, be sure to digital audio devices conforming to the same standards.



S/P DIF (Owner's Manual "Glossary")



Coaxial In and Optical In cannot be used simultaneously. Select one of the connectors for use. (p. 40)

Making a Multi-Track Recording 1 (Using Front Panel)

5. Carefully read the conditions for permission that are listed on the back cover of this manual, and if you agree to the conditions, press **[ENT/YES]**. After the display indicates “— Complete —,” you will return to Play condition. Now you will be able to make digital connections with your CD player. If you do not agree to the conditions, press **[EXIT/NO]**, and you will immediately return to Play condition.

■ To Prevent Digital Connections with CD Players

Use the following procedure when you want to prevent digital connections with CD players.

1. Press **[SHIFT] + [SYSTEM (▶)]** several times until “System PRM ?” appears in the display.
2. Press **[ENT/YES]**.
3. Press **PARAMETER [▶▶]** several times until “CD DigiREC → Off ?” appears in the display.
4. Press **[ENT/YES]**. After the display indicates “— Complete —,” you will return to Play condition. Subsequently it will no longer be possible to make digital connections with your CD player.

■ Select the Master Clock

Synchronize the VSR-880's reference clock (the master clock) with the digital signal from the digital audio device.

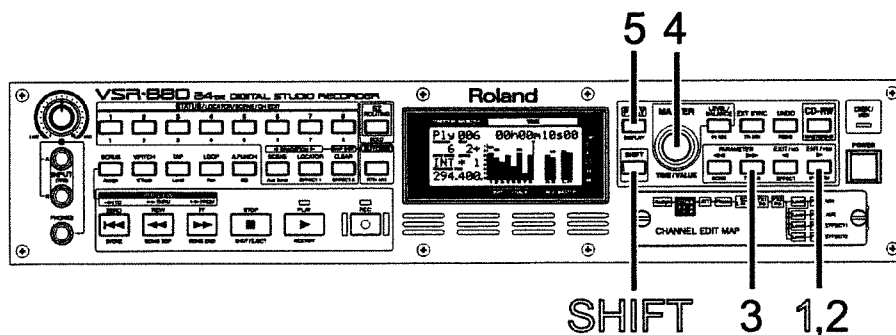

1. Press **[SHIFT] + [SYSTEM (▶)]** several times until “System PRM ?” appears in the display.
2. Press **[ENT/YES]**.
3. Press **PARAMETER [▶▶]** several times until “SYS MasterClk=” appears in the display.
4. Rotate the **TIME/VALUE dial** to switch the master clock, then press **[ENT/YES]**.

Making a Multi-Track Recording 1 (Using Front Panel)

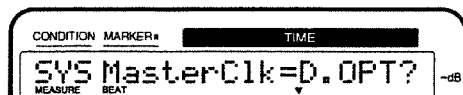

MasterCk (Master Clock)

This sets the VSR-880's reference clock. In this case, select "D.COA" or "D.OPT."

INT: Based on the VSR-880's reference clock.

D.COA: Based on the digital signal received from the COAXIAL IN connector.

D.OPT: Based on the digital signal received from the OPTICAL IN connector.

R-BUS: Based on the digital signal received from the R-BUS (RMDB2) connector.

(p. 53)

5. Press [PLAY (DISPLAY)]. Return to Play condition.

Select an Input Source

Here we will explain how to select an input source, using the example of recording a digital signal on tracks 1 and 2. Here we will explain how to select input sources, using the example of recording a digital signal (stereo) to tracks 1 and 2.

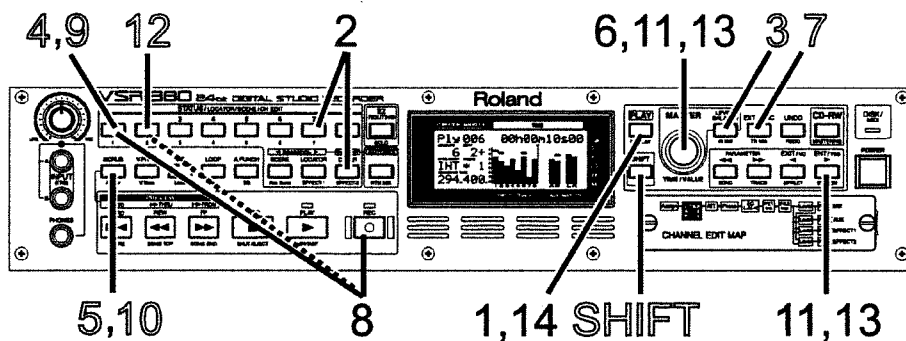

1. Press [PLAY (DISPLAY)].
2. Hold down **STATUS** ([1]–[8]: any track is OK) and press [CLEAR]. The assignments of input sources to tracks will be cleared.
3. Press [SHIFT] + [IN MIX (LEVEL/BALANCE)]. (Input Mixer)
4. Assign the digital signal to an input channel. Hold down [SHIFT] and press the **CH EDIT** ([1]–[8]) button for the input channel to which you wish to assign the digital signal. For example if you wish to assign the digital signal to input channel 1, you would press [1].
5. Hold down [SHIFT] and press [Assign (SCRUB)]. "Input=" appears in the display.



When you change the master clock value, clicking noise may happen. Please turn down the **Master Level** of the VSR-880, or the volume of the amplifier beforehand.



If "Digital In Lock" is Displayed, the reference clock for the sample rate is set by the digital signal from the DIGITAL IN connector. You can record using the digital connection.



If "Digital In Unlock" is Displayed, no digital signal is being received from the DIGITAL IN connector. Alternatively, it may indicate that the sample rate selected for the song does not match the sample rate of the digital device connected to the DIGITAL IN connector. In this state, you cannot record using the digital connection.

Making a Multi-Track Recording 1 (Using Front Panel)

6. Rotate the **TIME/VALUE** dial to select "DIGITAL."

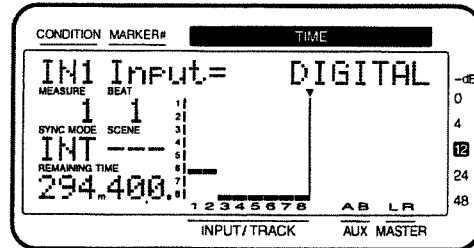

7. Press **[SHIFT] + [TR MIX (EXT SYNC)]**. (Track Mixer)
8. Select the recording track. Hold down **[REC]** and press **STATUS ([1]–[8])** of the desired track. For this example, hold down **[REC]** and press **[1]–[2]**. The STATUS indicator will blink red. (ready to record)
9. Hold down **[SHIFT]** and press **STATUS ([1]–[8]; left channel)** of the desired track. For this example, hold down **[SHIFT]** and press **[1]**.
10. Press **[SHIFT] + [Assign (SCRUB)]**.
11. Select the source that will be recorded on track 1. Use the **TIME/VALUE** dial to select the source that you wish to record, and press **[ENT/YES]**. In this example we will record the digital signal (left channel) that is assigned to input channel 1, so select "IN1" and press **[ENT/YES]**.
12. Hold down **[SHIFT]** and press **STATUS ([1]–[8]; right channel)** of the desired track. For this example, hold down **[SHIFT]** and press **[2]**.
13. Select the source that will be recorded on track 2. Use the **TIME/VALUE** dial to select the source that you wish to record, and press **[ENT/YES]**. In this example we will record the digital signal (right channel) that is assigned to input channel 2, so select "IN2" and press **[ENT/YES]**.

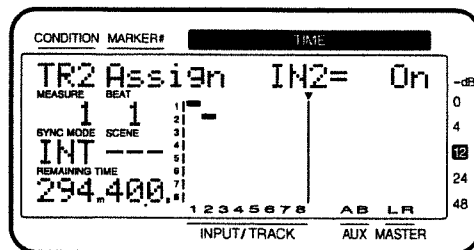

14. Now the digital signal can be recorded. Press **[PLAY (DISPLAY)]**. Return to Play condition.
15. As described in "Recording to the Tracks" step 9 (p. 30), record and check the contents.

MEMO

The digital signal (stereo) will be assigned to an adjacent odd-numbered and even-numbered channel simultaneously. The left channel of the digital signal will be assigned to the odd-numbered channel, and the right channel to the even-numbered channel.

Making a Multi-Track Recording1 (Using Front Panel)

Playing Back Two or More Tracks

■ Adjusting the Stereo Position of Each Track

If you wish to adjust the stereo position (pan) of each track, use the following procedure.

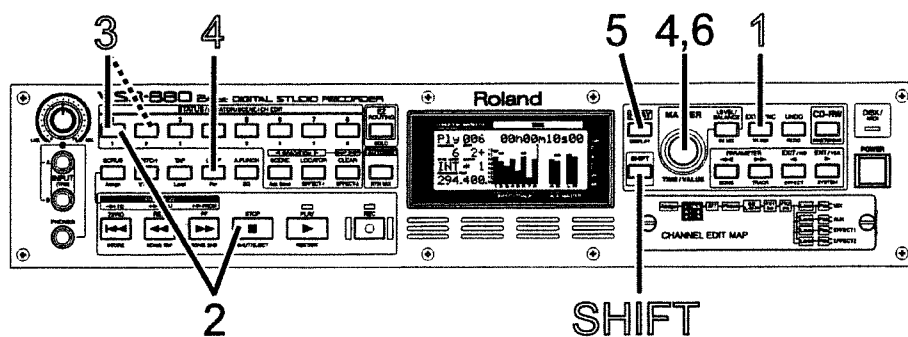

1. Press **[SHIFT] + [TR MIX (EXT SYNC)]**. (Track Mixer)
2. Hold down **[STOP]** and press **STATUS ([1]–[8])** of the track(s) that you wish to adjust the pan. The **STATUS** indicator will light green. (ready to play back)
3. Hold down **[SHIFT]** and press **STATUS** (Here, select [1] or [2]) of the track(s) that you wish to adjust the pan.
4. Press **[SHIFT] + [Pan (LOOP)]**.

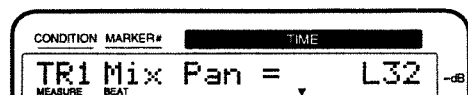

5. Press **[PLAY]**. The song will play back.
6. Rotate the **TIME/VALUE dial** to adjust the pan. Repeat steps 1–6 to adjust the pan of the other tracks.

NOTE

If you adjust the Mix Pan while sound is playing, you may notice “blips” in the sound. This is not a malfunction. If you find it annoying, adjust the equalizer when the sound is not playing.

Making a Multi-Track Recording 1 (Using Front Panel)

■ Adjusting the Tone of Each Track

A selectable 2-band (high, low) or 3-band (high, middle, low) parametric equalizer is provided for each channel. Here's how to use the equalizer to adjust the tone of each track.

Using the 3-Band Equalizer

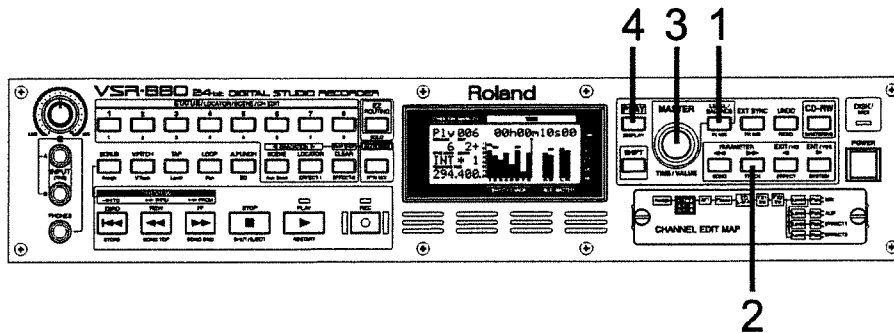

1. Press [LEVEL/BALANCE].
2. Press **PARAMETER** [▶▶] to let "EQ Sel=" appear in the display.
3. Rotate the **TIME/VALUE** dial to select equalizer.

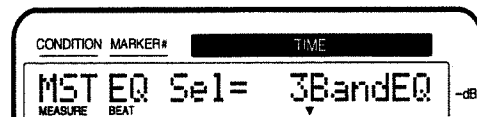

EQ Sel (Equalizer Select)

Select the type of equalizer that you wish to use.

2BandEQ: 2-band equalizer.

3BandEQ: 3-band equalizer.

4. Press [PLAY (DISPLAY)]. Return to Play condition.

Adjusting the Equalizer

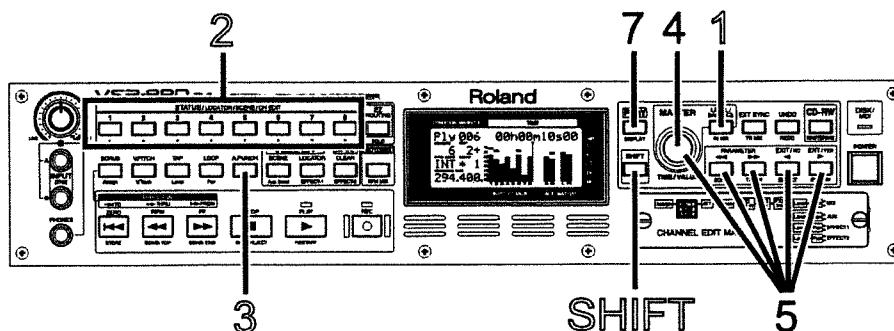

If you adjust the equalizer while sound is playing, you may notice "blips" in the sound. This is not a malfunction. If you find it annoying, adjust the equalizer when the sound is not playing.



The 3-band (low, mid, high) equalizer can be used on channel faders in only one mixer mode — either the Track mixer or Input mixer — at a time. You cannot use the equalizer in both mixers simultaneously on the same channel. For example, if you are using the 3-band equalizer on Track 1, then you cannot use it on Input 1.



If the **Record Mode** (recording mode) (p. 24) has been set to "VSR," it is not possible to use the equalizer (it will not be displayed).

Making a Multi-Track Recording 1 (Using Front Panel)

1. If you wish to adjust the equalizer for the input source, press **[SHIFT] + [IN MIX (LEVEL/BALANCE)]** (Input Mixer). If you wish to adjust the equalizer for an already-recorded track, press **[SHIFT] + [TR MIX (EXT SYNC)]** (Track Mixer).
2. Hold down **[SHIFT]** and press **CH EDIT** ([1]–[8]) for the channel or track whose equalizer setting you wish to adjust.
3. Press **[SHIFT] + [EQ (A.PUNCH)]**. "EQ Switch=" appears in the display.
4. Rotate the **TIME/VALUE dial** to select equalizer on and off.

EQ Switch (Equalizer Switch)

If you wish to use the equalizer, set this "On." If not, set this "Off." When equalizer settings are being made, the equalization curve will be shown graphically in the bar display. If this is "Off" the equalizer-related parameters will not be available. For this example, select "On" so that the equalizer will be applied.

5. Use **PARAMETER** [**◀**], [**▶**], [**◀**], [**▶**] and **TIME/VALUE dial** to make the setting.

EQL (Equalizer Low)

This adjusts the gain (-12 to 12 dB) and the center frequency (40 Hz to 1.5 kHz) of the low-range (shelving) equalizer.

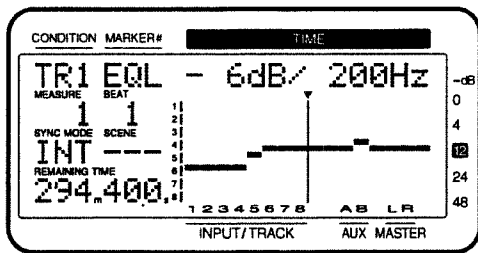

EQM (Equalizer Mid Gain)

This adjusts the gain (-12 to 12 dB) of the mid-range (peaking) equalizer.

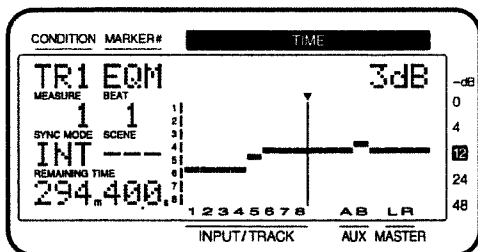

EQM (Equalizer Mid)

This adjusts the center frequency (200 Hz to 8 kHz) and Q (definition: 0.5 to 16) of the mid-range (peaking) equalizer.

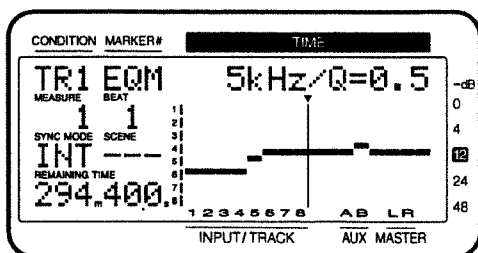

MEMO

The screens will change when you press **PARAMETER** [**◀**] or [**▶**]. Use [**◀**] or [**▶**] to access the parameter (gain or frequency) that you wish to adjust.

MEMO

When the 2-band equalizer is selected, it is not possible to adjust Equalizer Middle (it will not be displayed).

Making a Multi-Track Recording 1 (Using Front Panel)

EQH (Equalizer High)

This adjusts the gain (-12 to 12 dB) and the center frequency (500 Hz to 18 kHz) of the high-range (shelving) equalizer.

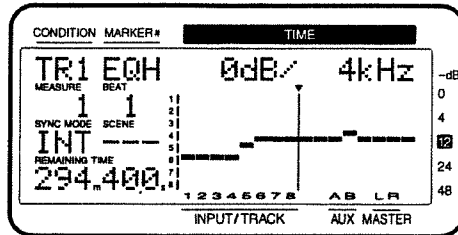

- Repeat Steps 1–6 if you wish to make adjustments to other equalizers.
- When you are finished making the adjustments, press **[PLAY (DISPLAY)]**. Return to Play condition. If necessary, save the song (p. 50).

Canceling the Recording

■ Checking the Time Available for Recording (Remaining Time)

Each time a performance is recorded on a track, hard disk capacity will be used up, and the remaining time available for recording will decrease. You may continue recording as long as there is sufficient capacity on the hard disk. The amount of free disk space available for recording the current song is displayed as “REMANING TIME” in the display. It is a good idea to check the remaining recording time before you start recording.

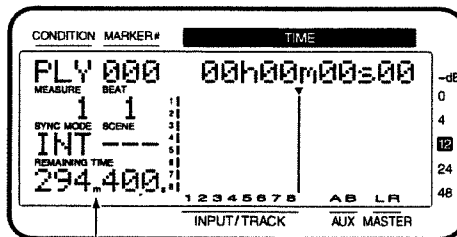

Remaining amount (in the example, 294minutes 40seconds)

Making a Multi-Track Recording 1 (Using Front Panel)

■ Canceling a Recorded Result (Undo/Redo)

If the recording level was too low, if you made a mistake in your performance, or if for any other reason you wish to re-do the recording, you can use the following procedure to cancel the contents of the recording. This is called the **Undo function**. You can also cancel the previously-executed Undo to return to the original state, and this is called the **Redo function**.

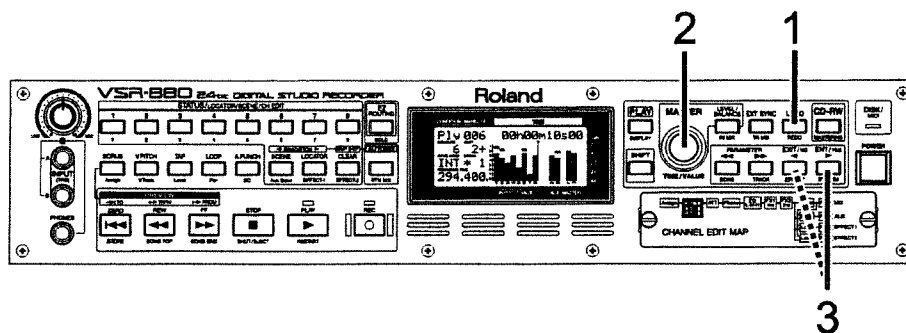

1. Press [UNDO].
2. "UNDO Level=" appears in the display. Use the **TIME/VALUE dial** to specify how many steps you wish to return.



3. Press [ENT/YES]. The UNDO indicator will light to show that the Undo operation has been executed successfully. If you decide not to execute Undo, press [EXIT/NO].

If you wish to cancel the last-executed Undo (i.e., if you wish to return to the original state), use the following procedure.

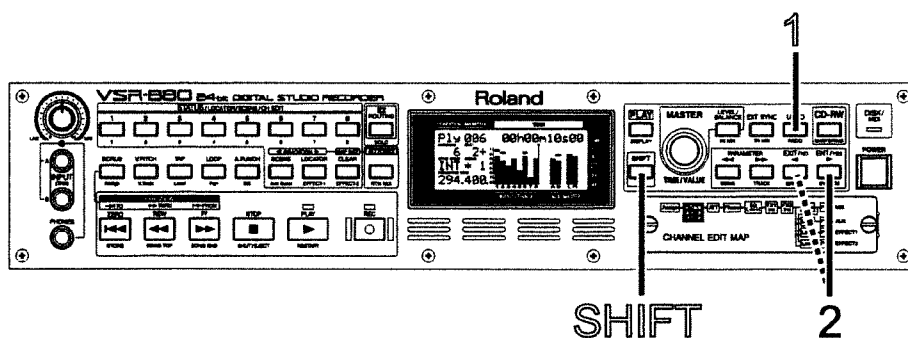

1. Make sure that the UNDO indicator is lit, then hold down [SHIFT] and press [REDO (UNDO)].
2. "REDO last UNDO ?" appears in the display. Press [ENT/YES]. If you decide not to execute Undo, press [EXIT/NO].

NOTE

When you execute Undo, the recorded data will appear to have disappeared. However, the data that is no longer played back will not be erased from the hard disk until you save that song (p. 50). For this reason, executing Undo will not increase the available recording time.

NOTE

If you save the song after executing Undo, it will no longer be possible to perform Redo (p. 50).

Making a Multi-Track Recording 1 (Using Front Panel)

■ Re-Recording a Specified Portion (Punch-In/Punch-Out)

When you listen to a performance that you recorded, you may notice that even though the overall performance is good, a mistake was made or the wrong lyrics were sung in just one location. In such cases you can use the following procedure to re-record just the portion in which the mistake occurred. This is called **Punch-in/Punch-out**.

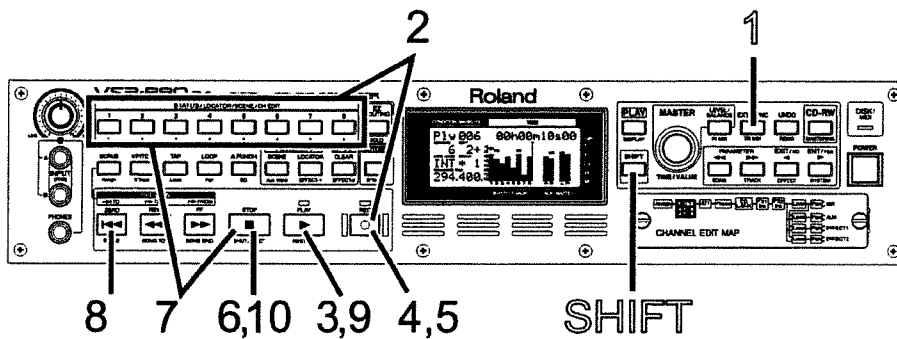

1. Press **[SHIFT] + [TR MIX (EXT SYNC)]**. (Track Mixer)
2. Hold down **[REC]** and press **STATUS ([1]-[8])** of the track that you wish to re-record. The STATUS indicator will blink red.
3. Press **[PLAY]**. The song will play back.

Punch-In Recording

When you perform punch-in recording, you must make sure that the previously-recorded track and the source now being recorded are at the same volume. During playback, you can alternately monitor the track and the source by pressing the **STATUS** button of the track that you wish to re-record. Compare the sounds to make sure that there is no difference in level between them. If necessary, use the **Mix Level** of the Input Mixer to adjust the recording level (p. 28).

4. At the point where you wish to begin re-recording, press **[REC]**. The REC indicator will light red, indicating that recording is occurring. Begin playing.
5. When you finish playing or singing, press **[REC]** once again. The REC indicator will go dark, indicating that you have returned to playback mode.
6. Press **[STOP]**. The song will stop.
7. Hold down **[STOP]** and press **STATUS ([1]-[8])** of the track that you re-record. The STATUS indicator will light green.
8. To listen to your recording, press **[ZERO]**. You will return to the beginning of the song.
9. Press **[PLAY]**. The song will play back. Use the **Mix Level** of the Track Mixer to adjust the volume to a comfortable level. (p. 21)
10. When you are finished listening the re-recorded song, press **[STOP]**.

NOTE

Although it will appear that the audio data is overwritten by this process, the data that is no longer played back is not actually erased from the hard disk. This means that the available recording time will decrease when you punch-in/punch-out. If you wish to increase the available recording time, please read "If "Disk Full!" appears in the display (Song Optimize)" (p. 49).

Making a Multi-Track Recording 1 (Using Front Panel)

Erasing Just a Portion of a Recording (Track Erase)

If instead of re-recording the portion where a mistake was made, you simply wish to erase the mistake, use the following procedure. The result will sound the same as recording silence over the unwanted section, without using additional disk space.

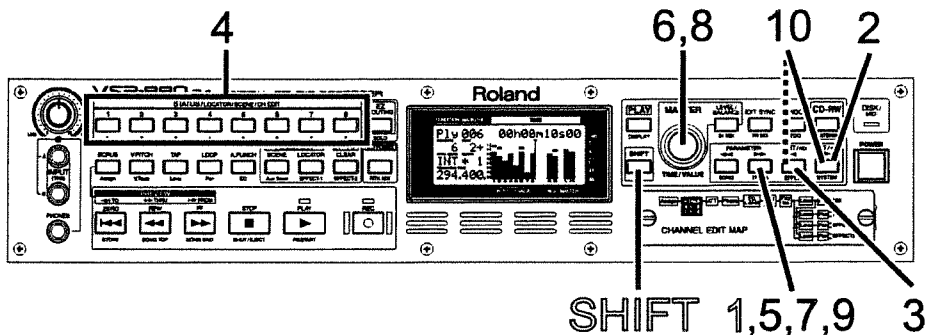

1. Press **[SHIFT] + [TRACK (▶▶)]** several times until "TRK Track Erase ?" appears in the display.
2. Press **[ENT/YES]**.
3. Press **[◀]** several times until "TRK Erase Tr.=?-?" appears in the display.
4. Press **STATUS ([1]–[8])** for the track on which you want to carry out Track Erase. The STATUS indicator will blink red.
5. Press **PARAMETER [▶▶]** until "TRK St=" appears in the display.
6. Rotate the TIME/VALUE dial to specify the starting time of the segment to be erased.

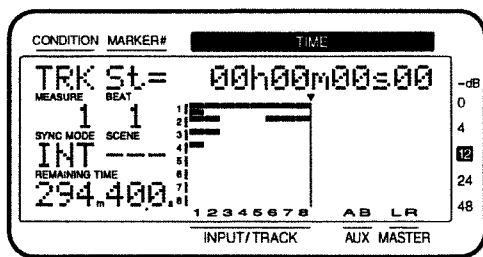

7. Press **PARAMETER [▶▶]**. "TRK End=" appears in the display.
8. Rotate the **TIME/VALUE dial** to specify the ending time of the segment to be erased.

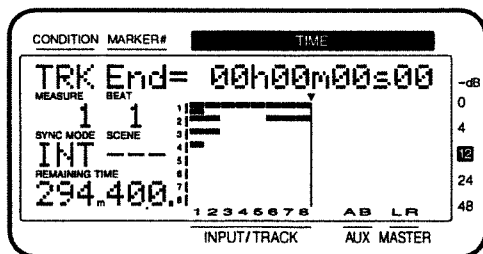

9. Press **PARAMETER [▶▶]**. "TRK Track Erase OK ?" appears in the display.

NOTE

Although it will appear that the audio data is erased by this process, the data that is no longer played back is not actually erased from the hard disk. This means that the available recording time will not increase when you use the Track Erase operation. If you wish to increase the available recording time, please read "If "Disk Full" appears in the display (Song Optimize)" (p. 49).

Making a Multi-Track Recording 1 (Using Front Panel)

10. Press [ENT/YES]. This executes Track Erase. If you wish to cancel, press [EXIT/NO].
11. When the erase is completed correctly, "Complete" appears in the display, and return to Play condition.

■ If "Disk Full!" appears in the display (Song Optimize)

When you perform punch-in recording or use operations such as Track Erase, the data that is no longer played back will remain on the disk drive without being actually deleted. The **Song Optimize** operation deletes this unneeded data from the hard disk, in order to increase the available space (recordable time) on the hard disk. This operation cannot be undone by the Undo function. Furthermore, recorded data that was deleted by the Song Optimize operation cannot be recovered.

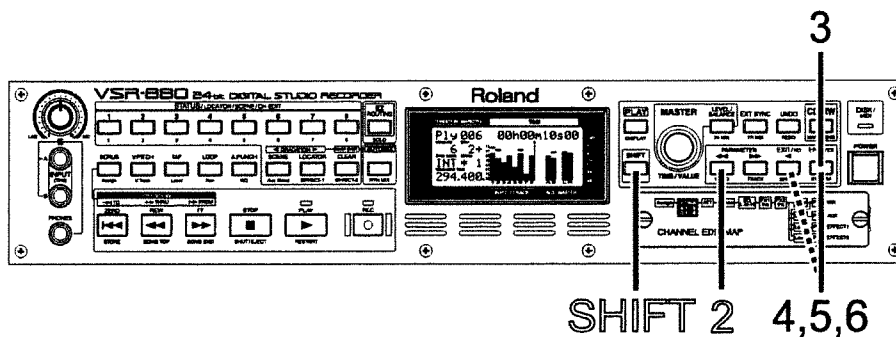

1. Select the song you want to optimize as the current song.
2. Press [SHIFT] + [SONG (◀◀)] several times until "Song Optimize?" appears in the display.
3. Press [ENT/YES].
4. "Song Optimize OK?" appears in the display. Press [ENT/YES]. If you wish to cancel Song Optimize, the press [EXIT/NO].
5. "Optimize Sure?" appears in the display. Press [ENT/YES] again. If you wish to cancel Song Optimize, the press [EXIT/NO].
6. A confirmation message appears in the display. Press [ENT/YES] again. If you wish to cancel the procedure, press [EXIT/NO].
7. When the optimize is finished, return to Play condition.

NOTE

Depending on the structure of the performance data, the vacant area (the remaining time for recording) may not increase as you expect.

NOTE

Be aware that, depending on conditions, it may take some time for the Optimize operation to be completed. This is not a malfunction. Do not turn the power off until the Optimize operation is completed.

Making a Multi-Track Recording 1 (Using Front Panel)

Saving Your Performance (Song Store)

The performance that you recorded will be lost if you simply turn off the power. It will also be lost if the power should be turned off by accident or power failure. Data that was lost in this way cannot be recovered. To avoid such accidents, use the following procedure to save your song to disk. When handling important song data or when you have been using the VS-1680 for an extended period, we recommend that you save your data frequently.

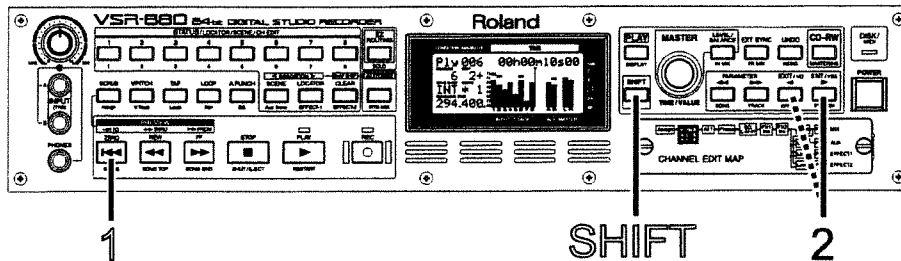

1. Hold down [SHIFT] and press [STORE (ZERO)].
2. "STORE OK ?" appears in the display. If you are satisfied with the recording, press [ENT/YES]. If you decide not to store the song, press [EXIT/NO].



The contents of the demo songs are protected from being changed or overwritten (Song Protect; p. 51). You cannot save operation with the demo songs. This means if you press [ENT/YES] at Step 2 when a demo song is selected, the message "Song Protected" will appear, and the procedure cannot be continued.



A song that was created on a device other than the VSR-880 (such as the VS-880 or VS-1680) cannot be re-saved on the VSR-880 (Owner's Manual "Compatibility"). For this reason if you press [ENT/YES] in step 2 when a non-VSR-880 song is selected, a warning message will appear, and you will not be able to continue the procedure.



When a song is saved, it will no longer be possible to use the Redo operation (p. 50)

Protecting Songs (Song Protect)

The possibility that a performance saved to the disk may still be mistakenly overwritten (recorded over), or that the song itself may be accidentally deleted has been considered. You can protect songs from being rewritten in situations such as these. The function is called **Song Protect**.

About Effective Use

Song Protect performs the same function as the protect tab or switch on floppy disks and magnet-optical disks. Thus, even if Song Protect is turned on, you can still store locate points and mark points, and carry out operations such as changing Scenes. However, when you try to save the work you have done, "Song Protected" appears in the display, and you are prevented from continuing any further with the save. However, when you remove Song Protect, any settings made when Song Protect was on are lost.

After you have finished all work for the day, turn on Song Protect immediately before shutting off the power to the VSR-880. Furthermore, right after turning on the power to the VSR-880 at the beginning of the day's operations, you should immediately turn off Song Protect.

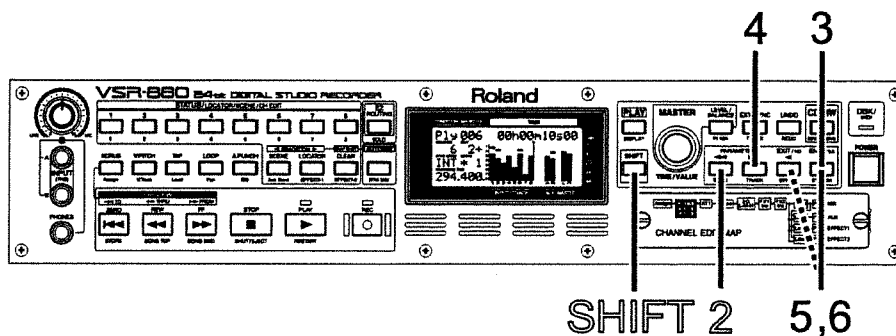

1. Make the current song the one to which you want to apply Song Protect.
2. Press [**SHIFT**] + [**SONG (◀◀)**] several times until "SNG Song Name/ Prtct?" appears in the display.
3. Press [**ENT/YES**]. Song name appears in the display.
4. Press **PARAMETER [▶▶]**. "SNG ChangePrtct → On?" appears in the display.
5. Press [**ENT/YES**]. If you wish to cancel, press [**EXIT/NO**].
6. "STORE Current?" appears in the display. If you wish to save the current song and then protect it, press [**ENT/YES**]. If you wish to protect the state in which Song Store was last executed without saving the current song, press [**EXIT/NO**].
7. The song will be protected. "SNG Complete" appears in the display, and return to Play condition.

Making a Multi-Track Recording 1 (Using Front Panel)

■ To Remove Song Protect

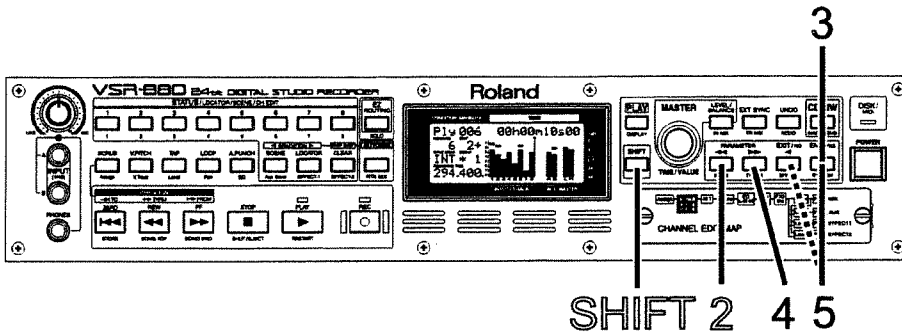

1. Select the song from which you currently want to remove the protect function.
2. Press **[SHIFT] + [SONG (◀◀)]** several times until "SNG Song Name/ Prtct?" appears in the display.
3. Press **[ENT/YES]**. Song name appears in the display.
4. Press **PARAMETER [▶▶]**. "SNG ChangePrtct → Off?" appears in the display.
5. Press **[ENT/YES]**. If you wish to cancel, press **[EXIT/NO]**.
6. Song protect will be disabled. "SNG Complete" appears in the display, and return to Play condition.

NOTE

It is not possible to defeat the Song Protect setting of a song that was created on a device other than the VSR-880 (such as the VS-880 or VS-1680). For this reason if you press **PARAMETER [▶▶]** in step 3 when a non-VSR-880 song is selected, a warning message will appear, and you will not be able to continue the procedure.

Making a Multi-Track Recording 2 (Using the Roland Digital Mixer)

As an example, we will explain how you can connect a Roland digital mixer (such as the VM-3100Pro) to the VSR-880 via R-BUS and perform multitrack recording. We will use one mic to record acoustic guitar, and another mic to record a vocal.



RMDB II, RMDB2 and R-BUS are the same standard of the Roland.

Using the R-BUS (INPUT 1-8/OUTPUT 1-8)

The VSR-880 has the R-BUS connector (DB-25 type) on its rear panel. Here we will explain how you can connect a mic to INPUT1 of the VM-3100Pro to pick up an acoustic guitar performance, and record it via R-BUS on track 5 of the VSR-880.

Connect audio devices (amp and speaker, sub-mixer, monitor amp or headphones etc.) to the output jacks of the VM-3100Pro.



Even if a Roland digital mixer (such as the VM-3100Pro) is connected to the VSR-880 via R-BUS (RMDB2), it is not possible to adjust the VSR-880's mixer section (input mixer / track mixer / return mixer) from the digital mixer.

■ Preparations for using the R-BUS

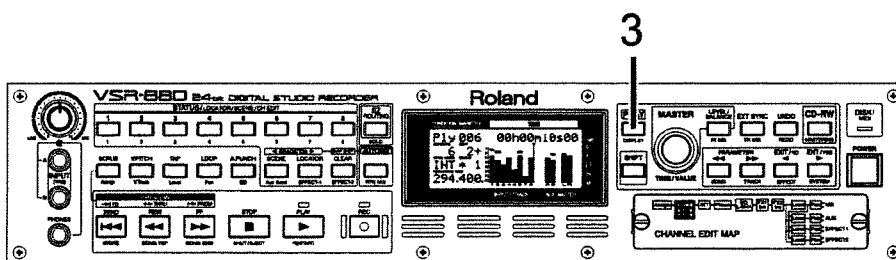

1. Synchronize the VSR-880's reference clock (the master clock) with the digital signal from the R-BUS connector. (p. 40)
 - 1-1. Press **[SHIFT] + [SYSTEM]** several times until "System PRM ?" appears in the display.
 - 1-2. Press **[ENT/YES]**.
 - 1-3. Press **PARAMETER [▶▶]** several times until "SYS MasterClk=" appears in the display.
 - 1-4. Rotate the **TIME/VALUE dial** to select "R-BUS," then press **[ENT/YES]**.
2. Turn the **Direct Out "On"** (p. 18).
 - 2-1. Press **[LEVEL/BALANCE]**.
 - 2-2. Press **PARAMETER [▶▶]** several times until "Direct Out=" appears in the display.
 - 2-3. Rotate the **TIME/VALUE dial** to select "On."
3. Press **[PLAY (DISPLAY)]**.



Connect the R-BUS connector of the VSR-880 with the R-BUS device that is described in Owner's Manual only. **Be careful NOT to connect any other devices (such as RS-232C-type, parallel-type or SCSI-type devices etc.) even though that have similar-looking connectors.**

To obtain an R-BUS cable (model: RBC-1, RBC-5), please contact your nearest Roland Service Center or authorized Roland distributor.

Making a Multi-Track Recording 2 (Using the Roland Digital Mixer)

■ Adjusting the Input Sensitivity

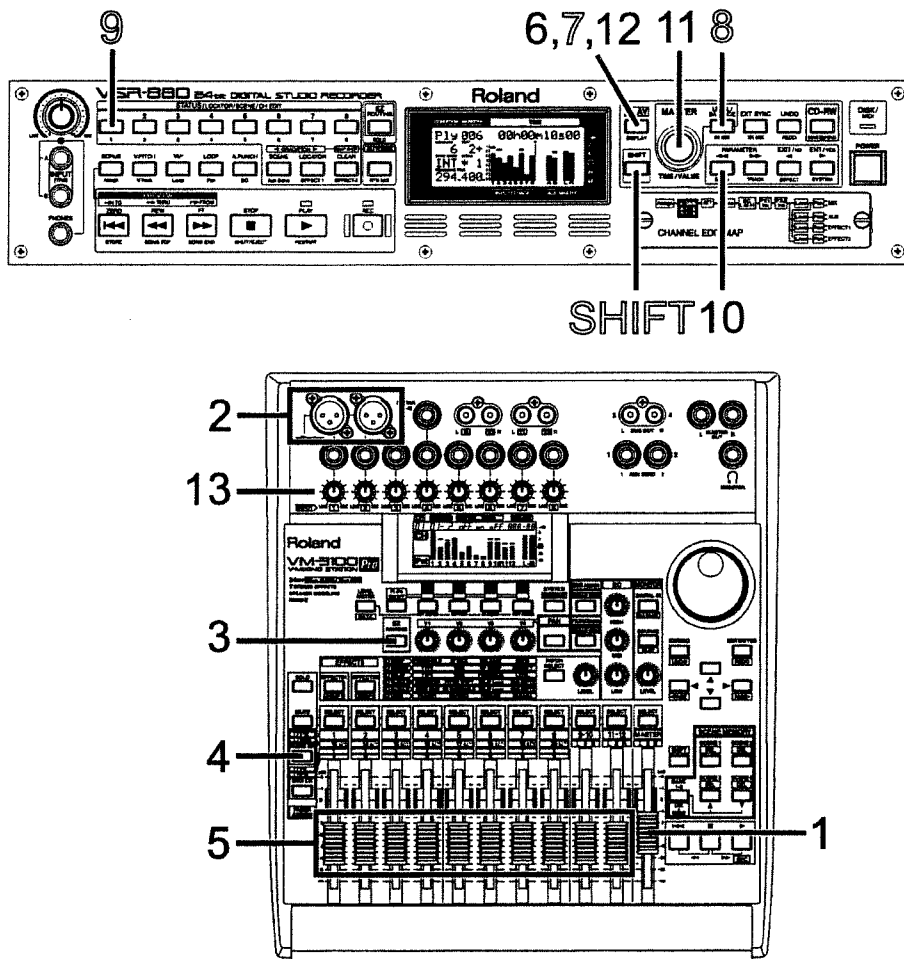

1. Lower the **MASTER fader** of the VM-3100Pro to the minimum position.
2. Connect the microphones to the INPUT jacks (1-2) of the VM-3100Pro's front panel.
3. Use the VM-3100Pro's **EZ Routing function** to recall the "16 [RMDB DIRCT]" template.
 - 3-1. Press **[EZ Routing]**.
 - 3-2. Totate the **VALUE dial** to select "16 [RMDB DIRCT]," then press **[ENTER/YES]**.
 - 3-3. Press **[LEVEL METER]**.
4. Press **[AUDIO CH]** of the VM-3100Pro to let the AUDIO CH indicator lights red. (AUDIO CH = 1-12)
5. Set all channel faders of the VM-3100Pr to the 0 dB position.
6. Press **[PLAY (DISPLAY)]**.
7. Press **[SHIFT] + [PLAY (DISPLAY)]** until "Pre Level" appears in the display. In this case, the volumes immediately after **ATT** (attenuator) (i.e., pre level) will be displayed.

NOTE

Howling could be produced depending on the location of microphones relative to speakers. This can be remedied by:

1. Changing the orientation of the microphone(s).
2. Relocating microphone(s) at a greater distance from speakers.
3. Lowering volume levels.

MEMO

In this case, VM-3100Pro channels 1-8 will be sent to digital outputs 1-8 of the RMDB2 connector (VM-3100 EZ Routing Set List, p.8).

Making a Multi-Track Recording 2 (Using the Roland Digital Mixer)

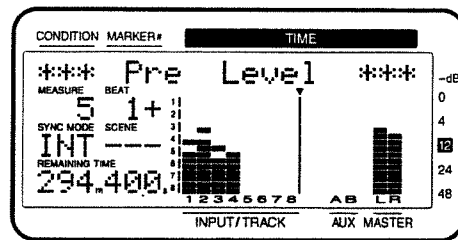

8. Press **[SHIFT] + [IN MIX (LEVEL/BALANCE)]**. (Input Mixer)
9. The signals that are input to the R-BUS connector will be assigned to input channels as follows. Hold down **[SHIFT]** and press the **CH EDIT** ([1]–[8]) button of the input channel that corresponds to the signal that is input from the R-BUS connector (the mic signal from the VM-3100Pro). For example if the mic is connected to INPUT1 of the VM-3100Pro, you would press **[1]**.

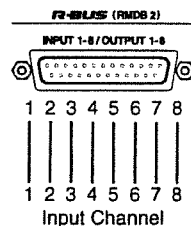

10. Press **PARAMETER** [◀] several times until "Input=" appears in the display.
11. Rotate **TIME/VALUE dial** to select "R-BUS."
12. Press **[PLAY (DISPLAY)]**.
13. While singing or playing into the mic, gradually raise the **INPUT knob** of the VM-3100Pro for the jack to which the mic is connected. For example if the mic is connected to INPUT 1, play your guitar or sing while you adjust the INPUT 1 knob.
14. Notice that the level meter of the VSR-880 moves, and that sound is output. Raise the VM-3100Pro's **gain knob** as high as possible without causing the sound to distort. Ideally, the level meter should be moving in the range of -12 to 0 dB in order to record with the optimal audio quality.

Connecting an Instrument Other than a Microphone

- If you wish to connect an electronic musical instrument (synthesizer etc.), connect it to any of the INPUT 3–INPUT 8 jacks. In this case, you will generally set the **INPUT knob** in the 9 o'clock region.
- If you are connecting an electric guitar or electric bass directly, connect it to the GUITAR (Hi-Z) jack by the INPUT 4. In this case, you will generally set the INPUT 4 knob in the 9 o'clock region.
- It is not possible to use both the INPUT 4 jack and the GUITAR (Hi-Z) jack simultaneously. If a plug is inserted into both jacks, the GUITAR (Hi-Z) jack will take priority. If you wish to use the INPUT 4 jack, do not connect anything to the GUITAR (Hi-Z) jack.

MEMO

The signals from the R-BUS connector will be simultaneously assigned to adjacent odd-numbered and even-numbered channels.

MEMO

When a mic is connected, you should generally set the gain knob in approximately the 3 o'clock position.

Recording On a Track

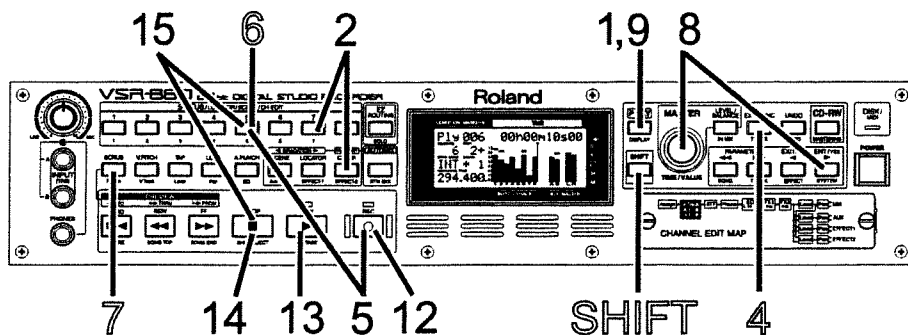

1. Press **[PLAY (DISPLAY)]**.
2. Hold down **STATUS** ([1]–[8]); any track is OK) and press **[CLEAR]**. This will clear any existing input routing assignments.
3. As described in “Adjusting the input sensitivity” (p. 54), make fine adjustments to the recording level.
4. Press **[SHIFT] + [TR MIX (EXT SYNC)]**. (Track Mixer)
5. Select the recording track. Hold down **[REC]** and press **STATUS** ([1]–[8]) of the desired track. For this example, hold down **[REC]** and press **[5]**. The STATUS indicator will blink red. (ready to record)
6. Hold down **[SHIFT]** and press **STATUS** ([1]–[8]) of the desired track. For this example, hold down **[SHIFT]** and press **[5]**.
7. Press **[SHIFT] + [Assign (SCRUB)]**.
8. Select the source that will be recorded to the track. Use the **TIME/VALUE dial** to select the source that you wish to record, and press **[ENT/YES]**. In this example we will be recording INPUT1 (the mic signal from the VM-3100Pro), so select “IN1” and press **[ENT/YES]**.

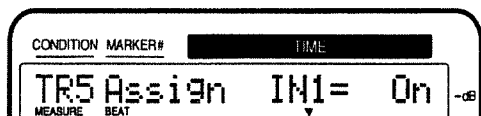

Assign ***

Specify the source/track/effect return which will assigned to each track for recording. If you press **[ENT/YES]** the display will indicate “On,” showing that it has been assigned for recording. If you press **[EXIT/NO]**, the display will indicate “Off,” and the signal will not be assigned (it will not be recorded).

The symbols displayed in “****” indicate the following signals.

- IN1–IN8: INPUT Jack 1–INPUT Jack 8 (FRONT/REAR/DIGITAL/R-BUS)
- TR1–TR8: Track 1–Track 8 (Track Bouncing/Mixdown)
- FX1: Effect 1 Return
- FX2: Effect 2 Return
- StIn: Stereo In

For example, a display of “TR5 Assign IN1= On” indicates that “the source from INPUT jack 1 has been assigned to track 5 for recording.”

Making a Multi-Track Recording 2 (Using the Roland Digital Mixer)

If you continue holding **STATUS** ([1]–[8]; any track is OK) for a short time longer, you can check which source is assigned to each track.

Assigned sources 1–8 (upper line)
Assigned tracks 1–8 (lower line)

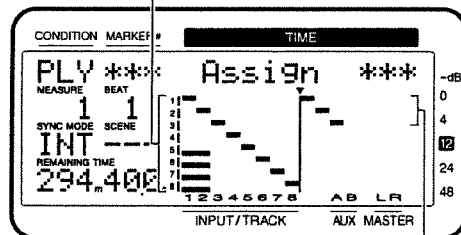

Recording Tracks (1–8)

Stereo In (first line)
Effect 1 (second line)
Effect 2 (third line)

9. Press **[PLAY (DISPLAY)]**.
10. Press **[AUDIO CH]** of the VM-3100Pro to let the AUDIO CH indicator lights green. (AUDIO CH=13-20)
11. Raise and lower track fader 17 (TR5) of the VM-3100Pro to verify that the volume changes. The track channel fader of the VM-3100Pro is used for monitoring. It does not affect the recording level. Even if you hear no sound, you can still record. Adjust the volume to a suitable level for listening.
12. Press **[REC]**. The REC indicator will blink red.
13. Press **[PLAY]**. The PLAY indicator will light green, and recording will begin. Start playing your acoustic guitar.
14. When you finish playing, press **[STOP]**.
15. While holding down **[STOP]**, press **STATUS** ([1]–[8]) for the track that you recorded. For this example, hold down **[STOP]** and press **[5]**. STATUS indicator will light green. (ready to play back)

Playing Back the Performance You Recorded

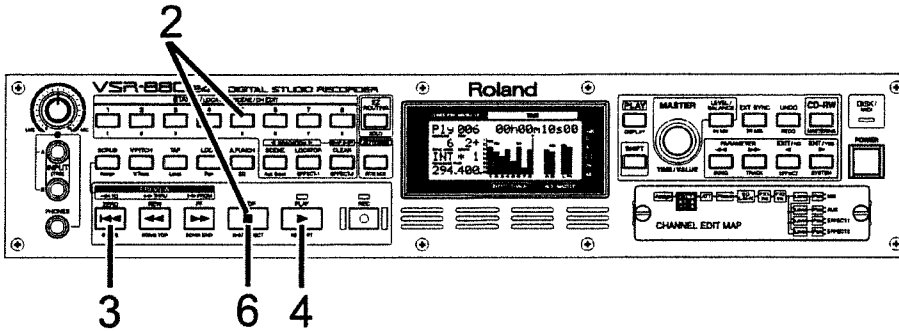

1. Press **[AUDIO CH]** of the VM-3100Pro to let the AUDIO CH indicator lights green. (AUDIO CH = 13-20)
2. Select the track(s) for playing back. Hold down **[STOP]** and press **STATUS** ([1]-[8]) of the track(s) that you wish to play back. For this example, hold down **[STOP]** and press **[5]**.
3. Press **[ZERO]**. You will return to the beginning of the song.
4. Press **[PLAY]**. The song will play back.
5. Use the channel fader 17 (TR5) and the master fader of the VM-3100Pro to adjust the volume to a comfortable level.
6. When playback ends, press **[STOP]**.

MEMO

For more detailed information, please refer to the Owner's Manual and leaflets of the VM-3100Pro.

Using the front panel input jacks (INPUT A/B)

The VSR-880 provides input jacks (TRS type phone jacks) on its front panel. Here we will explain how you can connect a mic to the INPUT A jack, and use it to record a vocal onto track 7 while you listen to the playback of the acoustic guitar that you previously recorded on track 5.

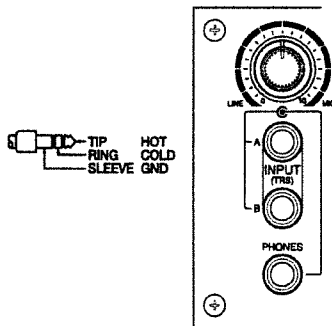

NOTE

Howling could be produced depending on the location of microphones relative to speakers. This can be remedied by:

1. Changing the orientation of the microphone(s).
2. Relocating microphone(s) at a greater distance from speakers.
3. Lowering volume levels.

■ Adjusting the Input Sensitivity

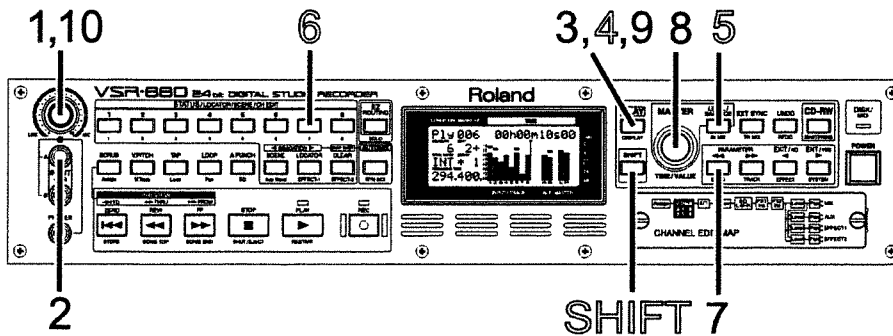

1. Lower the **INPUT knob** of the VSR-880 front panel to the minimum position.
2. Connect the microphone to the INPUT jack (A) of the VSR-880's front panel.
3. Press **[PLAY (DISPLAY)]**.
4. Press **[SHIFT] + [PLAY (DISPLAY)]** until "Pre Level" appears in the display. In this case, the volumes immediately after **ATT** (attenuator) (i.e., pre level) will be displayed.

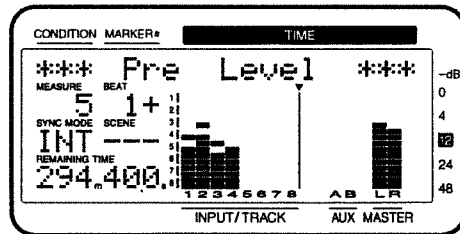

5. Press **[SHIFT] + [IN MIX (LEVEL/BALANCE)]**. (Input Mixer)
6. The signals that are input from the front panel input jacks can be assigned to input channels as follows. Hold down **[SHIFT]**, and press the **CH EDIT** ([1]-[8]) button for the input channel that you wish to use for the signal that is input from INPUT A (the mic). For example if the mic is connected to INPUT A, you would press **[1]**, **[3]**, **[5]** or **[7]**. For this example you should select **[7]**.

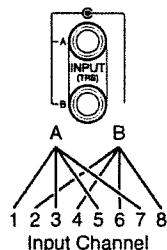

Making a Multi-Track Recording 2 (Using the Roland Digital Mixer)

7. Press **PARAMETER** [◀] several times until "Input=" appears in the display.
8. Rotate **TIME/VALUE** dial to select "FRONT."

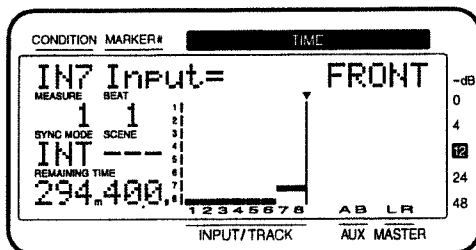

9. Press [PLAY (DISPLAY)].
10. While singing or playing into the mic, gradually raise the **INPUT knob** of the VSR-880.
11. Notice that the level meter of the VSR-880 moves, and that sound is output. Raise the VM-3100Pro's **gain knob** as high as possible without causing the sound to distort. Ideally, the level meter should be moving in the range of -12 to 0 dB in order to record with the optimal audio quality.



Adjust the **INPUT knob** to set the input sensitivity so that the analog inputs to both INPUT A/B are at an appropriate level.

■ Recording On Other Tracks (Overdubbing)

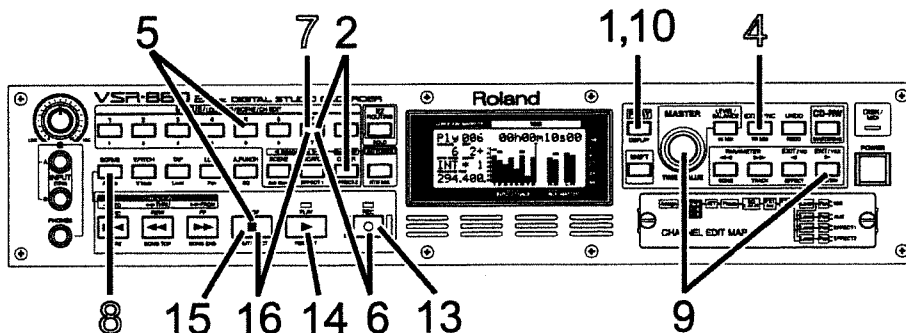

1. Press [PLAY (DISPLAY)].
2. Hold down **STATUS** ([1]-[8]:any track is OK) and press [CLEAR]. The assignments of input sources to tracks will be cleared.
3. As described in "Adjusting the input sensitivity" (p. 59), make fine adjustments to the recording level.
4. Press [SHIFT] + [TR MIX(EXT SYNC)]. (Track Mixer)
5. Select the playback track(s). Hold down [STOP], and press **STATUS** ([1]-[8]) of the track(s) that you wish to hear. For this example, hold down [STOP] and press [5]. The STATUS indicator will light green. (ready to play back)
6. Select the track(s) for recording. Hold down [REC] and press **STATUS** ([1]-[8]) of the track(s) that you wish to record. For this example, hold down [REC] and press [7]. The STATUS indicator will blink red. (ready to record)

Making a Multi-Track Recording 2 (Using the Roland Digital Mixer)

7. Hold down **[SHIFT]** and press **STATUS** ([1]–[8]) of the track(s) that you wish to record. For this example, hold down **[SHIFT]** and press **[5]**.
8. Press **[SHIFT]** + **[Assign (SCRUB)]**.
9. Select the source that will be recorded to the track. Use the **TIME/VALUE** dial to select the source that you wish to record, and press **[ENT/YES]**. For this example, we want to record the sound of the mic (INPUT A) assigned to input channel 7, so you should select “IN7” and press **[ENT/YES]**.

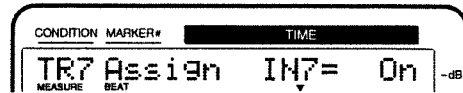

If you continue holding **STATUS** ([1]–[8]; any track is OK) for a short time longer, you can check which source is assigned to each track.

Assigned sources 1–8 (upper line)
Assigned tracks 1–8 (lower line)

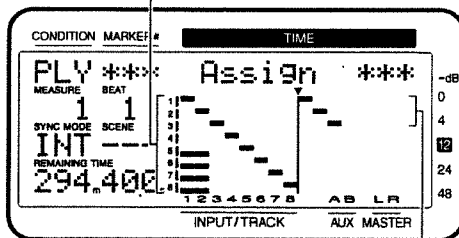

Recording Tracks (1–8)

Stereo In (first line)
Effect 1 (second line)
Effect 2 (third line)

10. Press **[PLAY (DISPLAY)]** of the VSR-880.
11. Press **[AUDIO CH]** of the VM-3100Pro to lit the AUDIO CH indicator lights green. (AUDIO CH=13-20)
12. Raise and lower channel fader 19 (TR7) to hear the volume change. The track channel fader of the VM-3100Pro is used for monitoring. It does not affect the recording level. You will be able to record even if you don't hear any sound. Adjust the level to a comfortable monitoring volume.
13. Press **[REC]**. The REC indicator will blink red.
14. Press **[PLAY]**. The PLAY indicator will light green, and recording will begin. Start playing your keyboard.
15. When you finish playing and recording, press **[STOP]**.
16. While holding down **[STOP]**, press **STATUS** ([1]–[8]) for the track that you recorded. For this example, hold down **[STOP]** and press **[7]**. STATUS indicator will light green. (ready to play back)

Using Effects (VS8F-2)

If VS8F-2 effects expansion board (sold separately) is installed, you can use up to two stereo effects without needing to connect any external devices to the VSR-880. Here's how to use effects when VS8F-2 has been installed.

If "No Effect Board" appears in the display

A VS8F-2 has not been installed. Internal effects cannot be used.

If this message appears even though a VS8F-2 has been installed, the VS8F-2 has not been recognized correctly. Turn off the power as described in "Turning Off the Power" (p. 16), and re-install the effect expansion board correctly.

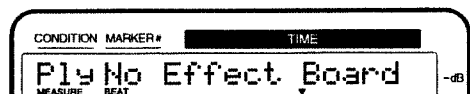

MEMO

For details on installing a VS8F-2, refer to "Installing the Effect Expansion Board" (p. 7).

MEMO

If **Direct Out** is turned "On," it is not possible to hear the sound of the effect from OUTPUT1-8. (They can heard in the headphones.) Here, set the Direct out to "Off." (p. 18)

Applying a Send/Return Type Effect During Playback

It is common to apply a send/return type effect such as reverb or delay during playback. The following example shows how you can apply reverb (FX1) to track 1 during playback.

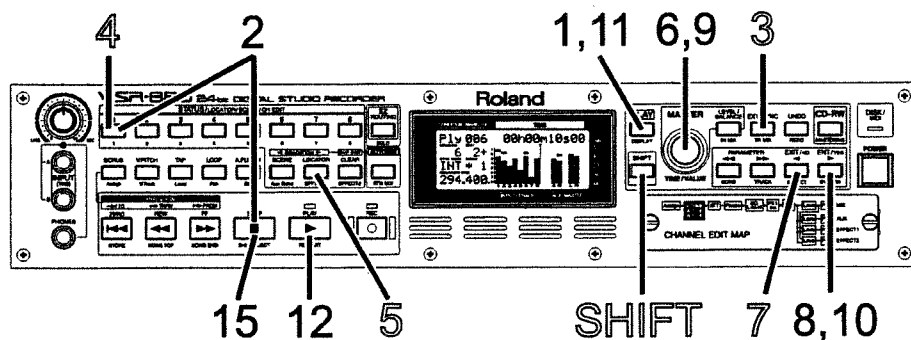

1. Press **[PLAY (DISPLAY)]**.
2. Select the playback track(s). Hold down **[STOP]** and press **[1]**. The STATUS indicator will light green. (ready to play back)
3. Press **[SHIFT] + [TR MIX(EXT SYNC)]**. (Track Mixer)
4. Hold down **[SHIFT]** and press **STATUS([1]-[8])** for the channel to which you want to apply the effect. For this example, press **[SHIFT] + [1]**.
5. Press **[SHIFT] + [EFFECT-1 (LOCATOR)]**.

- Rotate the **TIME/VALUE** dial to turn the effect on/off. Select either "PreFade" or "PstFade."

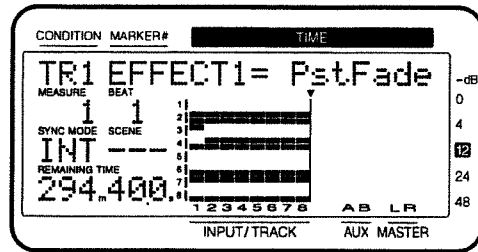

- Press **[SHIFT] + [EFFECT (◀)]** several times until "EFFECT-1 PRM?" appears in the display.
- Press **[ENT/YES]**. The number and name of the currently selected effect will be displayed, and you will be able to select the effect.
- Rotate the **TIME/VALUE** dial to select the effect you wish to use. For this example, select an effect such as "A00=RV:LargeHall."
- After selecting the effect, press **[ENT/YES]**.

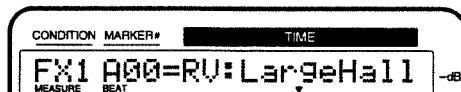

- Preparations are now complete. Press **[PLAY (DISPLAY)]** to return to the original display. The present signal flow (routing) is shown below.

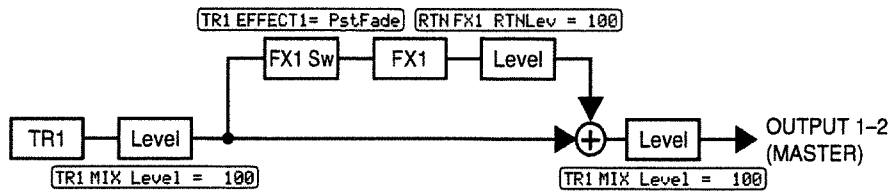

- Press **[PLAY]**. The song will play back.
- Adjust the volume of track 1.
 - Press **[SHIFT] + [TR MIX (EXT SYNC)]**. (Track Mixer)
 - Press **[SHIFT] + [1]**.
 - Press **[SHIFT] + [Level (TAP)]**.
 - Rotate the **TIME/VALUE** dial to adjust the **MixLevel**.
- Adjust the effect return level.
 - Press **[SHIFT] + [RTN MIX (AUTOMIX)]**. (Return Mixer)
 - Press **[SHIFT] + [7]**.
 - Rotate the **TIME/VALUE** dial to adjust the **FX1 RTNLev**. (FX1 return level)

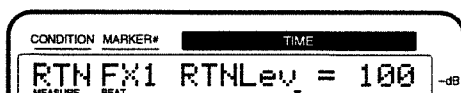

- When the song ends, press **[STOP]**.

Applying a Send/Return Type Effect Only to the Monitor Sound as You Record

The following example shows how a source connected to the INPUT 1 jack can be recorded on track 2 directly (without effects) while you apply a send/return type effect such as reverb or delay to the monitor sound. This is convenient when you wish to hear a reverb (FX1) on a vocal (for example) as you record, but would like to try out various reverb settings during playback.

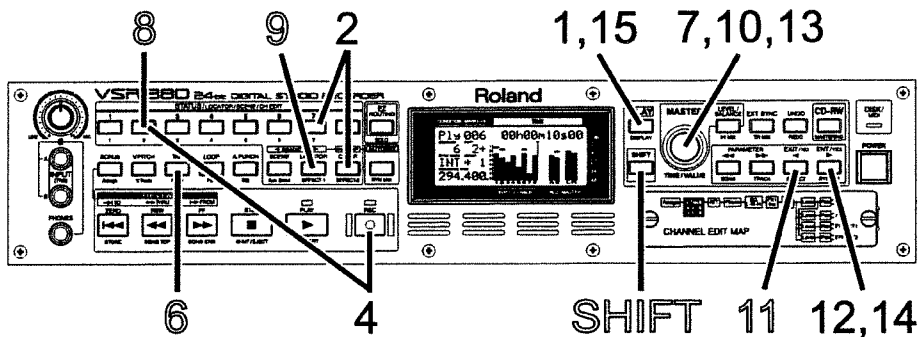

1. Press **[PLAY (DISPLAY)]**.
2. Hold down **STATUS** ([1]–[8]; any track is OK) and press **[CLEAR]**. The assignments of input sources to tracks will be cleared.
3. Make fine adjustments to the recording level as described in “Adjusting the input sensitivity” (p. 28).
 - 3-1. Press **[SHIFT] + [IN MIX (LEVEL/BALANCE)]**. (Input Mixer)
 - 3-2. Press **[SHIFT] + [1]**.
 - 3-3. Press **[SHIFT] + [Level (TAP)]**.
 - 3-4. Rotate the **TIME/VALUE** dial to adjust the **MixLevel**.
4. Select the recording track. Hold down **[REC]** and press **STATUS** ([1]–[8]) of the desired track. For this example, hold down **[REC]** and press **[2]**. The STATUS indicator will blink red. (ready to record)
5. Select the source that will be recorded on the track.
 - 5-1. Press **[SHIFT] + [TR MIX (EXT SYNC)]**. (Track Mixer)
 - 5-2. Hold down **[SHIFT]** and press **STATUS** ([1]–[8]) of the desired track. For this example, hold down **[SHIFT]** and press **[2]**.
 - 5-3. Press **[SHIFT] + [Assign (SCRUB)]**.
 - 5-4. Use the **TIME/VALUE** dial to select the source that you wish to record, and press **[ENT/YES]**. For this example, select “IN1” and press **[ENT/YES]**.

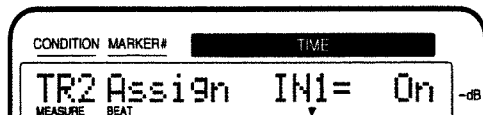

MEMO

At this time, the sound of input channel 1 will no longer be output directly from master out.

If you continue holding **STATUS** ([1]–[8]; any track is OK) for a short time longer, you can check which source is assigned to each track.

Assigned sources 1–8 (upper line)
Assigned tracks 1–8 (lower line)

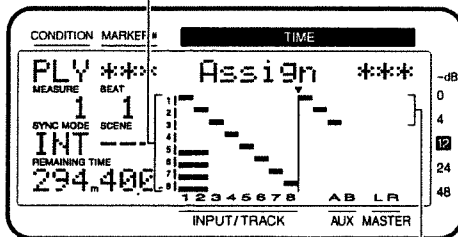

Recording Tracks (1–8)

Stereo In (first line)
Effect 1 (second line)
Effect 2 (third line)

6. Press **[SHIFT] + [Level (TAP)]**.
7. Rotate the **TIME/VALUE** dial to verify that the volume changes. The track mixer **Mix Level** is used for monitoring. It does not affect the recording level. Even if you hear no sound, you can still record. Adjust the volume to a suitable level for listening.
8. Hold down **[SHIFT]** and press **STATUS** ([1]–[8]) for the channel to which you want to apply the effect. For this example, press **[SHIFT] + [2]**.
9. Press **[SHIFT] + [EFFECT-1 (LOCATOR)]**.
10. Rotate the **TIME/VALUE** dial to turn the effect on/off. Select either "PreFade" or "PstFade."

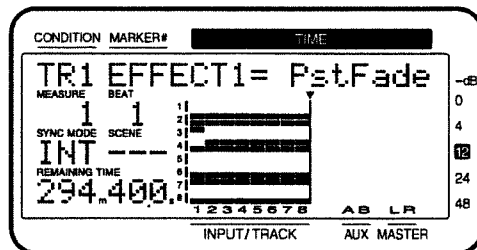

11. Press **[SHIFT] + [EFFECT (◀)]** several times until "EFFECT-1 PRM?" appears in the display.
12. Press **[ENT/YES]**. The number and name of the currently selected effect will be displayed, and you will be able to select the effect.

Using Effects (VS8F-2)

13. Rotate the **TIME/VALUE** dial to select the effect you wish to use. For this example, select an effect such as "A00=RV:LargeHall."

14. After selecting the effect, press [ENT/YES].



15. Preparations are now complete. Press [PLAY (DISPLAY)] to return to the original display. The present signal flow (routing) is shown below.

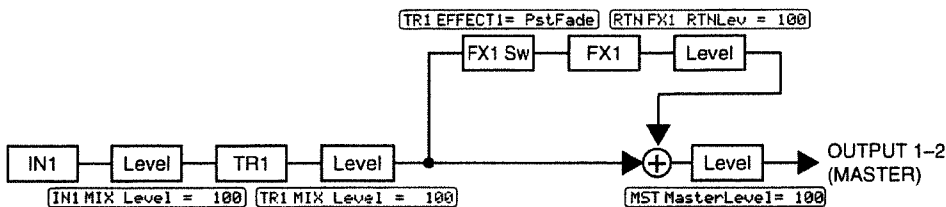

16. As described in "Recording On a Track" step 9 (p. 30), record a performance and then listen to it.

Switching Effects During Playback

Here's how you can switch effects while you playback a song, to hear the differences between various effects.

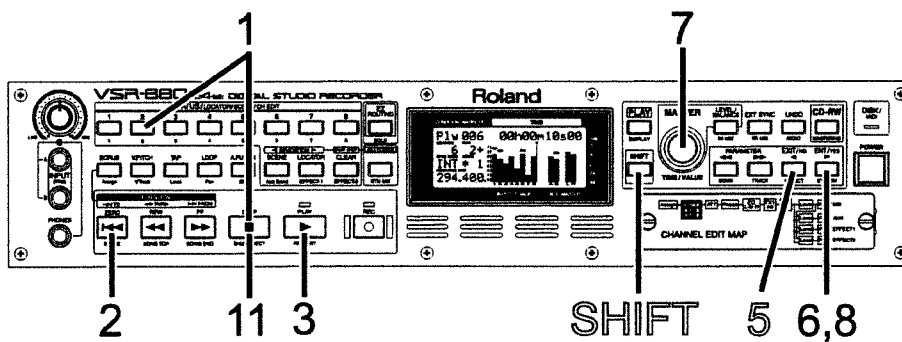

1. Select the track(s) for playback. Hold down [STOP] and press **STATUS** ([1]-[8]) for the track(s) that you wish to playback. For this example, hold down [STOP] + [3]. The STATUS indicator lights green.
2. Press [ZERO]. You will return to the beginning of the song.
3. Press [PLAY]. The song will play back.
4. Adjust the volume of track 2.
 - 4-1. Press [SHIFT] + [TR MIX (EXT SYNC)]. (Track Mixer)
 - 4-2. Press [SHIFT] + [2].
 - 4-3. Press [SHIFT] + [Level (TAP)].
 - 4-4. Rotate the **TIME/VALUE** dial to adjust the **MixLevel**.

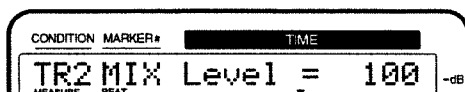

5. Press [SHIFT] + [EFFECT (◀)] several times until "EFFECT-1 PRM?" appears in the display.
6. Press [ENT/YES]. The number and name of the currently selected effect will be displayed, and you will be able to select the effect.
7. Rotate the **TIME/VALUE** dial to select the effect you wish to use. The difference will be easy to hear if you select an effect such as "A05=RV:VocalRoom."
8. After selecting the effect, press [ENT/YES].

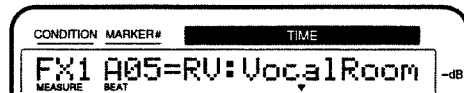

9. Adjust the effect return level.
 - 9-1. Press [SHIFT] + [RTN MIX (AUTOMIX)]. (Return Mixer)
 - 9-2. Press [SHIFT] + [7].
 - 9-3. Rotate the **TIME/VALUE** dial to adjust the **FX1 RTNLev.** (FX1 return level)
10. If you wish to hear other effects, repeat steps 7–9.
11. When the song ends, press [STOP].

Applying a Send/Return Type Effect While You Record

Here we will give an example of how a send/return type effect such as reverb can be applied to the source of the INPUT 1 jack, and the direct sound and effect sound recorded together on track 3. This is the method you will use when, for example, you wish to apply reverb to a vocal and record both the direct sound and effect sound together.

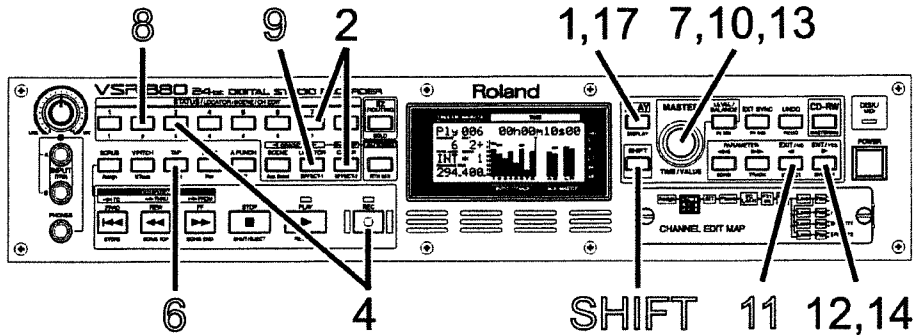

1. Press **[PLAY (DISPLAY)]**.
2. Hold down **STATUS** ([1]–[8]; any track is OK) and press **[CLEAR]**.
The assignments of input sources to tracks will be cleared.
3. Make fine adjustments to the recording level as described in “Adjusting the input sensitivity” (p. 28).
 - 3-1. Press **[SHIFT] + [IN MIX (LEVEL/BALANCE)]**. (Input Mixer)
 - 3-2. Press **[SHIFT] + [1]**.
 - 3-3. Press **[SHIFT] + [Level (TAP)]**.
 - 3-4. Rotate the **TIME/VALUE** dial to adjust the **MixLevel**.
4. Select the recording track. Hold down **[REC]** and press **STATUS** ([1]–[8]) of the desired track. For this example, hold down **[REC]** and press **[3]**.
The STATUS indicator will blink red. (ready to record)
5. Select the recording track.
 - 5-1. Press **[SHIFT] + [TR MIX (EXT SYNC)]**. (Track Mixer)
 - 5-2. Hold down **[SHIFT]** and press **STATUS** ([1]–[8]) of the desired track. For this example, hold down **[SHIFT]** and press **[3]**.
 - 5-3. Press **[SHIFT] + [Assign (SCRUB)]**.
 - 5-4. Use the **TIME/VALUE** dial to select the source that you wish to record, and press **[ENT/YES]**. For this example, select “IN1” and press **[ENT/YES]**.

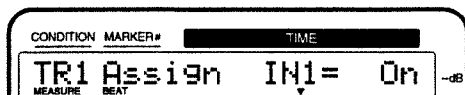

At this time, the sound of input channel 1 will no longer be output directly from master out.

If you continue holding **STATUS** ([1]-[8]; any track is OK) for a short time longer, you can check which source is assigned to each track.

Assigned sources 1-8 (upper line)
Assigned tracks 1-8 (lower line)

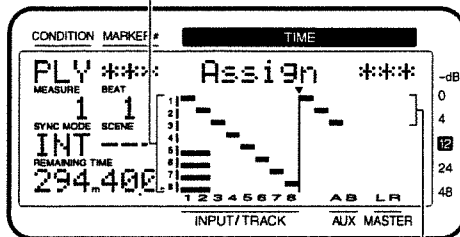

Recording Tracks (1-8)

Stereo In (first line)
Effect 1 (second line)
Effect 2 (third line)

6. Press **[SHIFT] + [Level (TAP)]**.
7. Rotate the **TIME/VALUE dial** to verify that the volume changes. The track mixer **Mix Level** is used for monitoring. It does not affect the recording level. Even if you hear no sound, you can still record. Adjust the volume to a suitable level for listening.
8. Select the input channel to which you want to apply the effect. (For this example, [1]).
 - 8-1. Press **[SHIFT] + [IN MIX (LEVEL/BALANCE)]**.
 - 8-2. Press **[SHIFT] + [1]**.
9. Press **[SHIFT] + [EFFECT-1 (LOCATOR)]**.
10. Rotate the **TIME/VALUE dial** to turn the effect on/off. Select either "PreFade" or "PstFade."

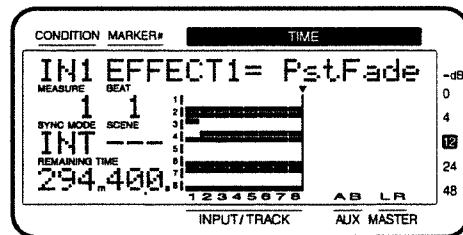

Be sure to turn off the effect switch of track channel 3. Otherwise, you will create a feedback loop.

11. Turn off the effect switch for the track channel that you want to record. (For this example, [3]).
 - 11-1. Press **[SHIFT] + [TR MIX (EXT SYNC)]**.
 - 11-2. Press **[SHIFT] + [3]**.
 - 11-3. Press **[SHIFT] + [EFFECT-1 (LOCATOR)]**.
 - 11-4. Rotate the **TIME/VALUE dial** to select "Off."
12. Press **[SHIFT] + [EFFECT (◀)]** several times until "EFFECT-1 PRM?" appears in the display.
13. Press **[ENT/YES]**. The number and name of the currently selected effect will be displayed, and you will be able to select the effect.

Using Effects (VS8F-2)

14. Rotate the **TIME/VALUE** dial to select the effect you wish to use. For this example, select an effect such as "A00=RV:LargeHall."

15. After selecting the effect, press **[ENT/YES]**.

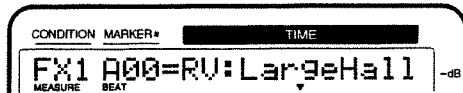

16. Adjust the effect return level.

16-1. Press **[SHIFT] + [RTN MIX (AUTOMIX)]**. (Return Mixer)

16-2. Press **[SHIFT] + [7]**.

16-3. Rotate the **TIME/VALUE** dial to adjust the **FX1 RTNLev**. (FX1 return level)

17. Assign the effect return to a recording track.

17-1. Press **[SHIFT] + [TR MIX (EXT SYNC)]**. (Track Mixer)

17-2. Hold down **[SHIFT]** and press **STATUS** ([1]-[8]) of the desired track. For this example, hold down **[SHIFT]** and press **[3]**.

17-3. Press **[SHIFT] + [Assign (SCRUB)]**.

17-4. Use the **TIME/VALUE** dial to select the effect return that you wish to record, and press **[ENT/YES]**. For this example select "FX1" and press **[ENT/YES]**.

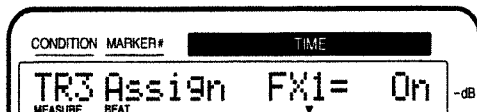

MEMO

At this time, the return signal from the effect will no longer be output directly to the master out.

If you continue holding **STATUS** ([1]-[8]; any track is OK) for a short time longer, you can check which source is assigned to each track. fig.05-08.e

Assigned sources 1-8 (upper line)
Assigned tracks 1-8 (lower line)

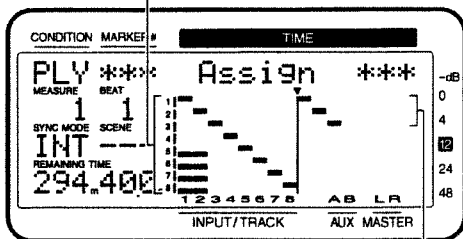

Recording Tracks (1-8)

Stereo In (first line)
Effect 1 (second line)
Effect 2 (third line)

18. Preparations are now complete. Press **[PLAY (DISPLAY)]** to return to the original display. The present signal flow (routing) is shown below.

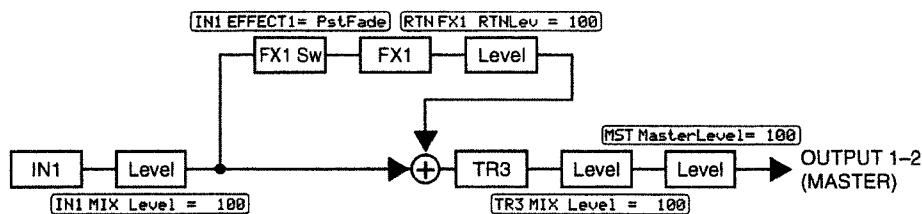

19. As described in "Recording On a Track" step 9 (p. 30), record a performance and then listen to it.

Applying an Insertion-Type Effect During Playback

When playing back an acoustic guitar or vocal, it is common to insert an effect such as “Guitar Multi” or “Vocal Multi.” Here we will give an example of applying an insertion-type effect such as Mic Simulator (FX2) to track 1 during playback.

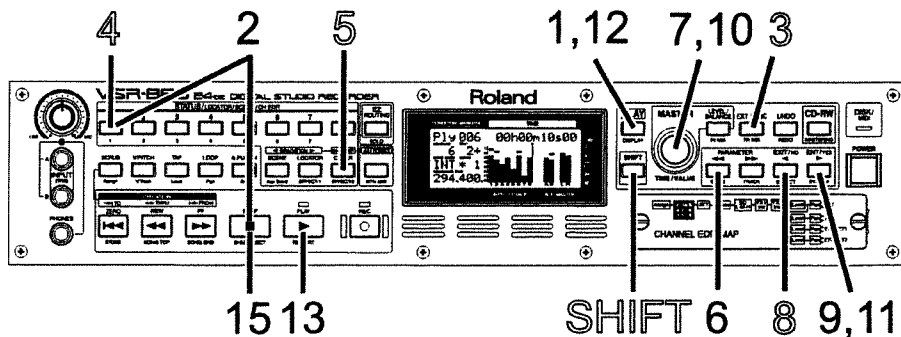

1. Press **[PLAY (DISPLAY)]**.
2. Select the track that you wish to playback. Hold down **[STOP]** and press **[1]**. The STATUS indicator will light green. (ready to playback)
3. Press **[SHIFT] + [TR MIX (EXT SYNC)]**. (Track Mixer)
4. Hold down **[SHIFT]** and press **STATUS([1]–[8])** for the track channel to which you wish to apply the effect. For this example, press **[SHIFT]+[1]**.
5. Press **[SHIFT] + [EFFECT-2 (CLEAR)]**.
6. Press **PARAMETER [<<]**.
7. Rotate the **TIME/VALUE dial** to turn the effect on/off. Select “Insert.”

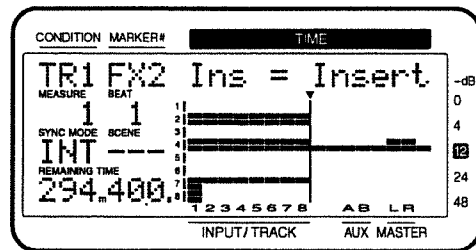

8. Press **[SHIFT] + [EFFECT (<◀)]** several times until “EFFECT-2 PRM?” appears in the display.
9. Press **[ENT/YES]**. The number and name of the currently selected effect will be displayed, and you will be able to select the effect.



If the display indicates “FX2—” the effect (FX2) is inserted into another channel, and therefore cannot be inserted into this channel (p. 73). Either turn off effect insertion for the channel that is using the effect, or insert a different effect into this channel.

Using Effects (VS8F-2)

10. Rotate the **TIME/VALUE** dial to select the effect you wish to use. For this example, select an effect such as "B28=MS:DR20 → 87."

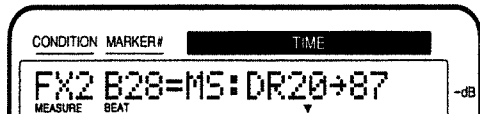

11. After selecting the effect, press **[ENT/YES]**.
12. Preparations are now complete. Press **[PLAY (DISPLAY)]** to return to the original display. The present signal flow (routing) is shown below.

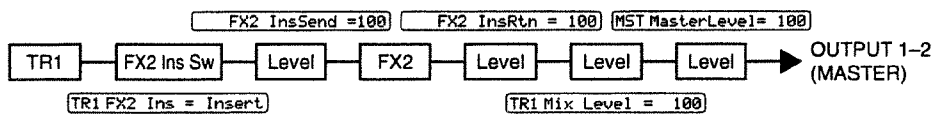

13. Press **[PLAY]**. The song will play back.
14. Adjust the volume of track 1.
- 14-1. Press **[SHIFT] + [TR MIX (EXT SYNC)]**. (Track Mixer)
 - 14-2. Press **[SHIFT] + [1]**.
 - 14-3. Press **[SHIFT] + [Level (TAP)]**.
 - 14-4. Rotate the **TIME/VALUE** dial to adjust the **MixLevel**.
15. When the song ends, press **[STOP]**.

■ Inserting the Same Effect into Another Track as Well

If in step 7 you selected "Insert" or "InsertS," that effect cannot be inserted into another channel/track. If you selected "InsertL" or "InsertR," that effect can be inserted into only one other channel/track.

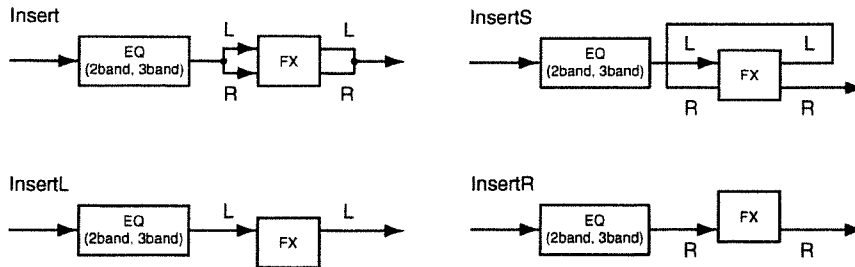

■ If You Wish to Use the Same Effect Both as Send/Return and Insertion

It is not possible to use the same effect for both insertion and send/return.

Even if the **FXIns** (Effect Insert Switch) parameter is set to except "Off," the **EFFECT** (Effect Switch) parameter can be set to either "PreFade" or "PstFade." This is because the VSR-880 is able to send the signal of the FX bus not only to the effect but also to another output jack.

For example if you insert FX2 into track 1, the FX2 bus will not be used (it will be vacant). In this situation if you set the track 2 **EFFECT2** to "PstFade," the track 2 signal will be sent to the FX2 bus, but it will not be sent to the effect itself (FX2). Since the signal of the FX bus can be assigned to the outputs Digital out 1/2, AUX out A/B, Master, and Monitor, you can make settings so that the signal of each track is sent from separate outputs. In other words if the effect (FX2) is inserted, you can use the unused FX bus (FX2) as an AUX bus.

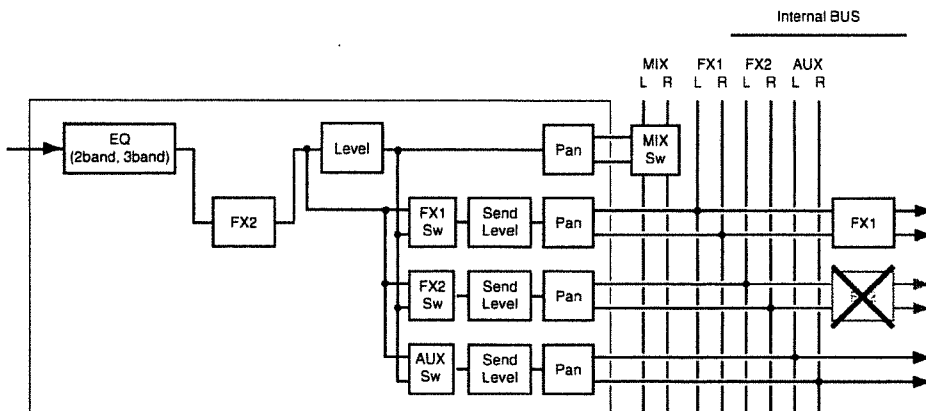

Using Effects (VS8F-2)

Applying an Insertion-Type Effect During Recording

When recording electric guitar or vocals etc., it is common to insert an effect such as Guitar Multi or Vocal Multi. Here we will describe how you can connect an electric guitar to the INPUT A jack of front panel, apply an effect (FX2), and record it on track 1.

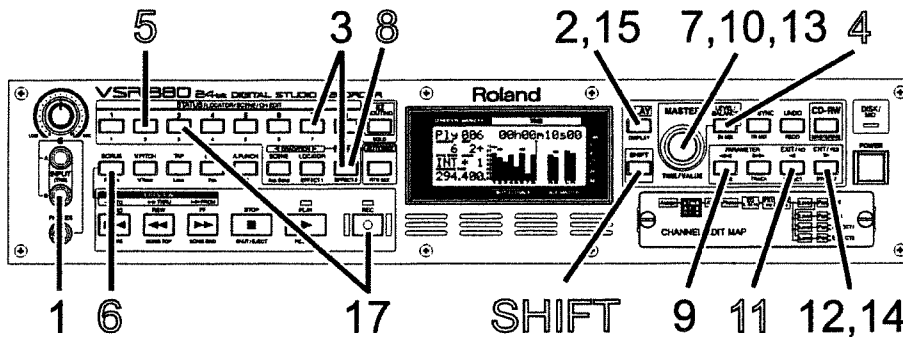

1. Connect an electric guitar to the INPUT A jack of front panel.
2. Press [PLAY (DISPLAY)].
3. Hold down STATUS ([1]–[8]; any track is OK) and press [CLEAR]. The assignments of input sources to tracks will be cleared.
4. Press [SHIFT] + [IN MIX (LEVEL/BALANCE)]. (Input Mixer)
5. Hold down [SHIFT] and press STATUS([1]–[8]) for the channel to which you want to apply the effect. For this example, press [SHIFT] + [2].
6. Press PARAMETER[<<<] several times until “Input=” appears in the display.
7. Rotate the TIME/VALUE dial to select “FRONT.”
8. Press [SHIFT] + [EFFECT-2 (CLEAR)].
9. Press PARAMETER [<<<] several times until “IN2 FX2 Ins =” appears in the display.
10. Rotate the TIME/VALUE dial to turn the effect on/off. Select “Insert.”

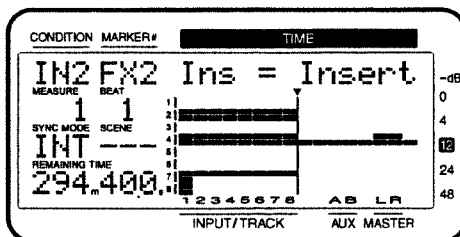

MEMO

In order to record the electric guitar with the best possible sound quality, please use an active-type guitar. Alternatively, use a direct box (such as the BOSS DI-1) or a compact-type effect unit. In this case, the compact effect unit will be used to lower the impedance. Thus, turn the power on and the effect off if you do not need to use the effect.

NOTE

If the display indicates “FX2—,” the effect (FX2) is inserted into another channel, and therefore cannot be inserted into this channel (p. 73). Either turn off effect insertion for the channel that is using the effect, or insert a different effect into this channel.

11. Press [SHIFT] + [EFFECT (◀)] several times until "EFFECT-2 PRM?" appears in the display.
12. Press [ENT/YES]. The number and name of the currently selected effect will be displayed, and you will be able to select the effect.
13. Rotate the **TIME/VALUE dial** to select the effect you wish to use. For this example, select an effect such as "A41=GT:Rock Lead."
14. After selecting the effect, press [ENT/YES].



15. Preparations are now complete. Press [PLAY (DISPLAY)] to return to the original display. The present signal flow (routing) is shown below.

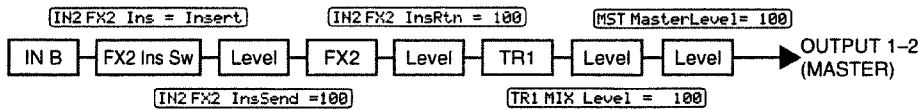

16. Make fine adjustments to the recording level as described in "Adjusting the input sensitivity" (p. 59).
 - 16-1. Lower the **INPUT knob** of the VSR-880 front panel to the minimum position.
 - 16-2. While playing an electric guitar, gradually raise the **INPUT knob** of the VSR-880.
17. Select the recording track. Hold down [REC] and press **STATUS** ([1]-[8]) of the desired track. For this example, hold down [REC] and press [1]. The STATUS indicator will blink red. (ready to record)
18. Select the source that will be recorded on the track.
 - 18-1. Press [SHIFT] + [TR MIX (EXT SYNC)]. (Track Mixer)
 - 18-2. Hold down [SHIFT] and press **STATUS** ([1]-[8]) of the desired track. For this example, hold down [SHIFT] and press [1].
 - 18-3. Press [SHIFT] + [Assign (SCRUB)].
 - 18-4. Use the **TIME/VALUE dial** to select the source that you wish to record, and press [ENT/YES]. For this example, select "IN1" and press [ENT/YES].

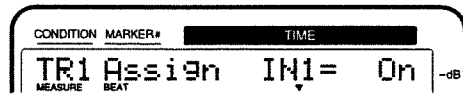

MEMO

Hold down [SHIFT], and press the **CH EDIT** ([2], [4], [6] or [8]) button for the input channel that you wish to use for the signal that is input from INPUT B jack (the guitar).

MEMO

At this time, the sound of input channel 1 will no longer be output directly from master out.

Using Effects (VS8F-2)

If you continue holding **STATUS** ([1]-[8]; any track is OK) for a short time longer, you can check which source is assigned to each track.

Assigned sources 1-8 (upper line)
Assigned tracks 1-8 (lower line)

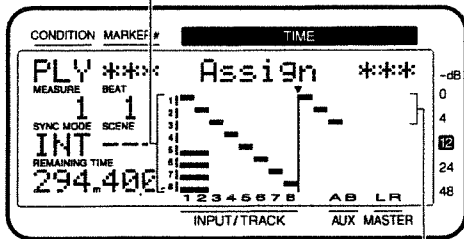

Recording Tracks (1-8)

Stereo In (first line)
Effect 1 (second line)
Effect 2 (third line)

19. Preparations are now complete. Press **[PLAY (DISPLAY)]** to return to the original display. The present signal flow (routing) is shown below.

20. As described in "Recording On a Track" step 9 (p. 30), record a performance and then listen to it.

Add Finishing Touches to Your Song

Here we will explain the procedure by which a recorded performance can be mixed down on the VSR-880 to a two-track stereo master, and then recorded as an original audio CD.



In order to create an original audio CD, you will need the Roland CD recorder (sold separately).

Combining the Performances of Multiple Tracks (Track Bouncing)

Performances that are recorded on two or more tracks can be mixed, and re-recorded on one or two other vacant tracks. This process is called **Track Bouncing**, and is convenient when you are beginning to run out of vacant tracks.

Here we will demonstrate an example of mixing down a performance that was recorded on tracks 1–4, and applying reverb (FX1) to the entire song as we re-record it to tracks 5 and 6 in stereo.

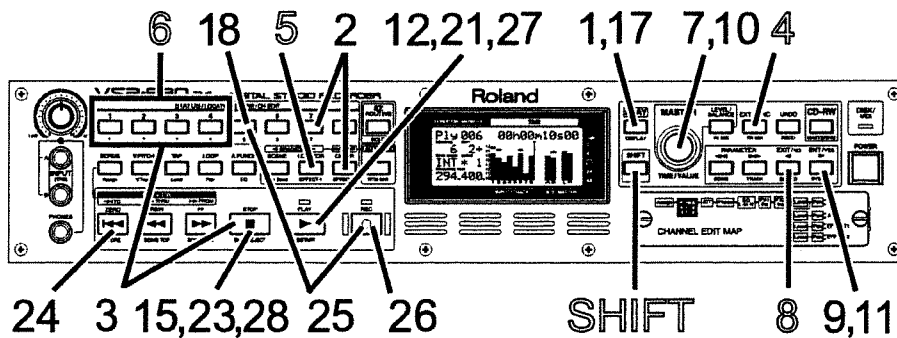

If the VS8F-2 effect expansion board has not been installed, it will not be possible to use the internal effects. (p. 7)

1. Press **[PLAY (DISPLAY)]**.
2. Hold down **STATUS** ([1]–[8]; any track is OK) and press **[CLEAR]**. This will clear any existing input and/or track routing assignments.
3. Select the playback track(s). Hold down **[STOP]**, and press **STATUS** ([1]–[8]) of the track(s) that you wish to mixdown. For this example, hold down **[STOP]** and press **[1]–[4]**. The STATUS indicators will light green. (ready to play back)
4. Press **[SHIFT] + [TR MIX (EXT SYNC)]**. (Track Mixer)
5. Press **[SHIFT] + [EFFECT-1 (LOCATOR)]**.
6. Hold down **[SHIFT]** and press **STATUS** ([1]–[8]) for the channel to which you want to apply the effect. For this example, press **[SHIFT] + [1]–[4]**.
7. Rotate the **TIME/VALUE** dial to turn the effect on/off. Select either "PreFade" or "PstFade."

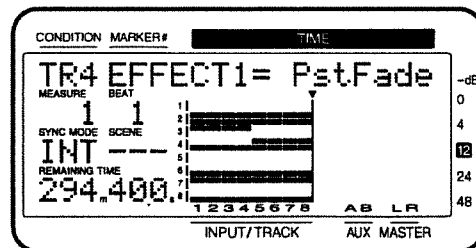

Be sure to turn off the effect switch of track channels 5 and 6.

Add Finishing Touches to Your Song

8. Press **[SHIFT] + [EFFECT (◀)]** several times until "EFFECT-1 PRM?" appears in the display.
9. Press **[ENT/YES]**. The number and name of the currently selected effect will be displayed, and you will be able to select the effect.
10. Rotate the **TIME/VALUE dial** to select the effect you wish to use. For this example, select an effect such as "A00=RV:LargeHall."

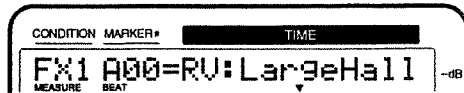

11. After selecting the effect, press **[ENT/YES]**.
12. Press **[PLAY]**. The song will play back.
13. Adjust the volume balance of the tracks. At this time, the sound that you are monitoring (volume levels and pan) will be recorded on tracks 5 and 6 just as you hear it. It is best to record at as high a level as possible without allowing the sound to distort.
 - 13-1. Press **[SHIFT] + [TR MIX (EXT SYNC)]**. (Track Mixer)
 - 13-2. Press **[SHIFT] + [Level (TAP)]**.
 - 13-3. Press **[SHIFT] + [1]-[4]**.
 - 13-4. Rotate the **TIME/VALUE dial** to adjust the **MixLevel**.
14. Adjust the effect return level. At this time, the sound that you are monitoring will be recorded to tracks 5 and 6 exactly as you hear it.
 - 14-1. Press **[SHIFT] + [RTN MIX (AUTOMIX)]**. (Return Mixer)
 - 14-2. Press **[SHIFT] + [7]**.
 - 14-3. Rotate the **TIME/VALUE dial** to adjust the **FX1 RTNLev.** (FX1 return level)



15. When you finish adjusting the volume, press **[STOP]**. The song will stop.
16. Turn on channel link for the recording tracks.
 - 16-1. Press **[SHIFT] + [TR MIX (EXT SYNC)]**. (Track Mixer)
 - 16-2. Hold down **[SHIFT]** and press **SELECT** ([5] or [6]) for one of the track channels you wish to record (whether left or right does not matter).
 - 16-3. Press **PARAMETER** [**◀**] or [**▶**] to "Channel Link=" appears in the display.
 - 16-4. Rotate the **TIME/VALUE dial** to turn the Channel Link "On."

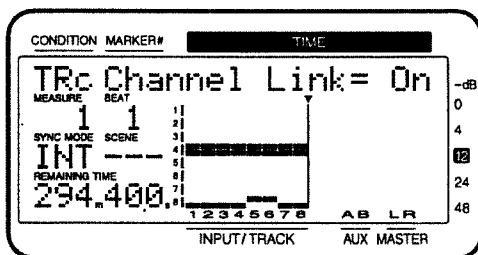

Add Finishing Touches to Your Song

17. Press **[PLAY (DISPLAY)]** to return to the original display screen.
18. Press **STATUS** ([5] or [6]) so that the STATUS indicator lights orange.
(ready to monitor)
19. Assign the playback tracks (1–4) and the effects return (FX1) to the recording tracks (track c: 5&6).
 - 19-1. Press **[SHIFT] + [TR MIX (EXT SYNC)]**. (Track Mixer)
 - 19-2. Hold down **[SHIFT]** and press **STATUS** ([5] or [6]) of the desired track.
 - 19-3. Press **[SHIFT] + [Assign (SCRUB)]**.
 - 19-4. Use the **TIME/VALUE dial** to select the source that you wish to record, and press **[ENT/YES]**. For this example, select "TR1"–"TR4" and "FX1" respectively, and then press **[ENT/YES]**.



Channel Link (Owner's Manual "Glossary")

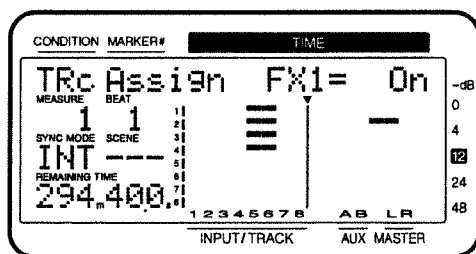

At this time, the sounds of track 1–4 and FX1 return will no longer be output directly from master out.

If you continue holding **STATUS** ([1]–[8]; any track is OK) for a short time longer, you can check which source is assigned to each track.

Assigned sources 1–8 (upper line)
Assigned tracks 1–8 (lower line)

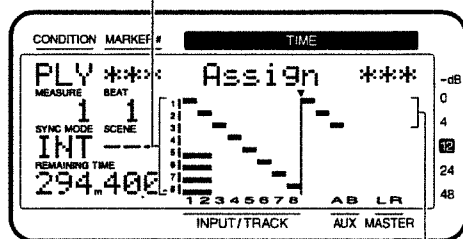

Recording Tracks (1–8)

Stereo In (first line)
Effect 1 (second line)
Effect 2 (third line)

Add Finishing Touches to Your Song

20. With these settings, tracks 1-4 and the effect return can be monitored on track c (7 and 8).

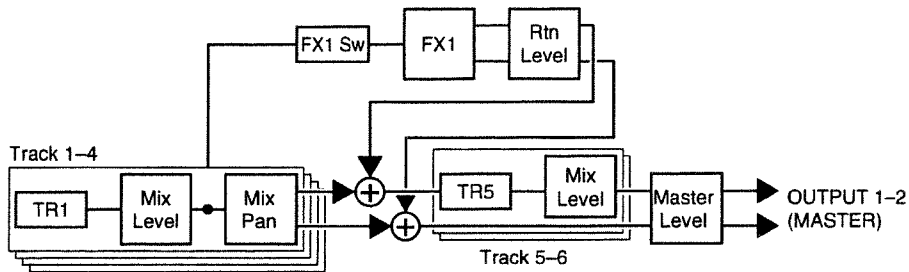

21. Press **[PLAY]**. The song will play back.

22. Adjust the volume of track c (5 and 6). **Mix Level** is used for monitoring. It does not affect the recording level. Even if you hear no sound, you can still record. Adjust the volume to a suitable level for listening.

22-1. Press **[SHIFT] + [TR MIX (EXT SYNC)]**. (Track Mixer)

22-2. Press **[SHIFT] + [5] or [6]**.

22-3. Press **[SHIFT] + [Level (TAP)]**.

22-4. Rotate the **TIME/VALUE dial** to adjust the **MixLevel**.

23. Press **[STOP]**.

24. Press **[ZERO]**. You will return to the beginning of the song.

25. Hold down **[REC]** and press **[STATUS]** ([1]–[8]) of the track that you wish to record. For this example, hold down **[REC]** and press **[5] or [6]**. The **STATUS indicator will blink red**.

26. Press **[REC]**. The REC indicator will blink red.

27. Press **[PLAY]**. The PLAY indicator will light green, and recording will begin.

28. When you finish recording, press **[STOP]**. The song will stop.

29. Listen to the recorded result.

29-1. Press **[ZERO]**. You will return to the beginning of the song.

29-2. Mute tracks 1–4 (so that they will not produce sound). Press **STATUS** ([1]–[4]) so they are not lit.

29-3. Get ready for play pack track c. Hold down **[STOP]** and press **STATUS** ([5] or [6]). The STATUS indicator will light green.

29-4. Press **[PLAY]**. The song will play back. Adjust the volume to a comfortable listening level.

Create Master Data (Mastering Room)

In order to create an original audio CD, you can specify two of the VSR-880's tracks as the left track and right track, and write them to a CD-R disc. Let's adjust the balance and effects for each track to create mastering tracks (mixdown/mastering).

■ Mixdown to Mastering Tracks

While performing a mixdown, it is common to insert an effect such as a parametric equalizer or an overall compressor. For this example, we will insert the Mastering Tool Kit (FX1) to adjust the overall volume balance as we mixdown.

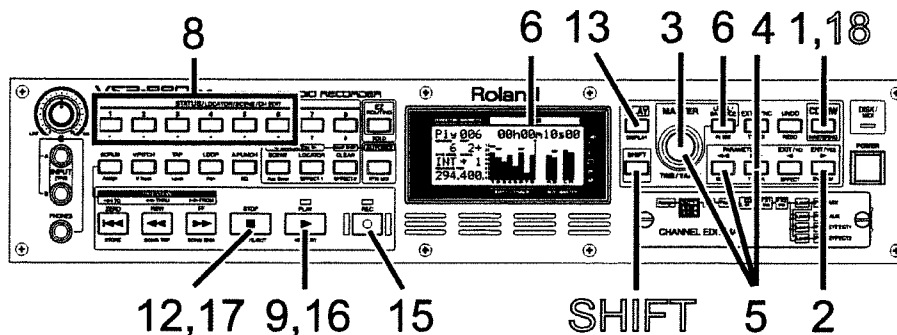

1. Press [CD-RW] several times until "CD-R Mastering Room?" appears in the display.
2. Press [ENT/YES]. "MasteringSw=" appears in the display.
3. Rotate the **TIME/VALUE dial** to select "On." The CD-RW indicator blinks, indicating that the Mastering Room is on.
4. Press **PARAMETER** [▶▶]. "MasStatus=" appears in the display.
5. As necessary, use **PARAMETER** [◀◀] or [▶▶] and the **TIME/VALUE dial** to make the following settings.

MasStatus (mastering track status)

Specify the status of the mastering tracks.

Rec: Play back tracks 1-6 while recording them to the mastering tracks (7 and 8).

Play: Play back the mastering tracks (7 and 8). The sound of tracks 1-6 will not be output from the MASTER jacks.

V.Track

Select the two V-tracks (L and R) that will be assigned as mastering tracks. The mastering tracks are fixed at tracks 7 and 8. When a new song is created, V-track 8 of tracks 7 and 8 (7-8, 8-8) will be assigned as the mastering tracks.



Even if you adjust the mixer or apply effects to each track during playback, the results will not be written to the CD-R disc.



If the VS8F-2 effect expansion board has not been installed, it will not be possible to use the internal effects. (p. 7)



When the mastering room is on, **MasStatus (status)** can be switched by pressing **STATUS** ([7] or [8]).

Add Finishing Touches to Your Song

After Rec (after recording)

Specify the time location of the mastering track to which the mixdown will be recorded. When creating an original audio CD, it is usually best to select "to ZERO."

ZERO: Place the data starting at 00h00m00s00f

L:0s: Place the data after the end of the last phrase in the mastering tracks.

L:2s: Place the data two seconds after the end of the last phrase in the mastering tracks.

L:4s: Place the data four seconds after the end of the last phrase in the mastering tracks.

Stay: Place the data at the time location at which it was actually recorded.

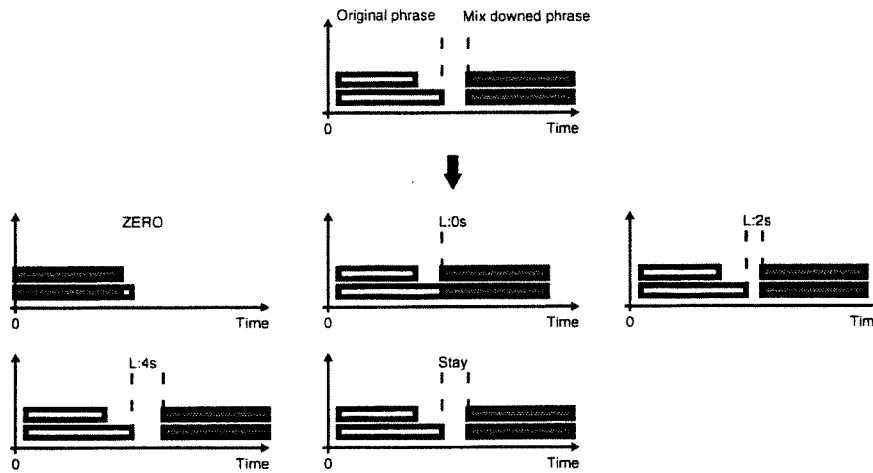

AutoMarker

If this is turned "On," a track number marker will automatically be assigned to the beginning of the phrase that is mixed down. Normally you will set this "On."

CDR RecMode (CDR recording mode)

If this is turned "On," the performance data recorded in the mastering tracks will be set to a recording mode of "CDR" regardless of the recording mode of the current song (p. 24). In this case, you can omit the step of creating an image file when writing the song to a CD-R disc.

6. Insert the effect (FX1) into the master out.

6-1. Press [LEVEL/BALANCE].

6-2. Press PARAMETER [▶▶] several times until "FX1 Ins Sw =" appears in the display.

6-3. Rotate the TIME/VALUE dial to select "On."

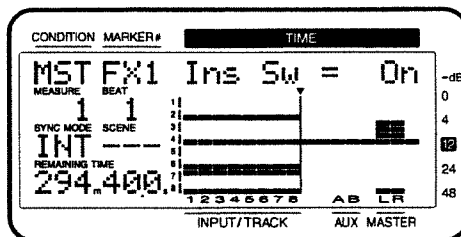

6-4. As necessary, use PARAMETER [◀◀] or [▶▶] and the TIME/VALUE dial to make the following settings.



Depending on the After Rec (after recording) setting or on the location relative to other markers, the display may indicate "Can't Set Marker," and the track number marker may not be assigned.



Performance data that was recorded to the mastering tracks with a CDR RecMode (CDR recording mode) setting of "On" can be played back only in the mastering room. (It cannot be played back in Play condition.)

Add Finishing Touches to Your Song

FX1 InsSend (FX1 insert send level)

Adjust the volume level of the signal that is sent to the insertion effect (0 to 127).
By default, this will be "100."

FX1 InsRtn (FX1 insert return level)

Adjust the volume level of the signal that is output from the insertion effect (0 to 127).
By default, this will be "100."

7. Select effects patch.

7-1. Press **[SHIFT] + [EFFECT (◀)]** several times until "EFFECT-1 PRM?" appears in the display.

7-2. Press **[ENT/YES]**. The number and name of the currently selected effect will be displayed, and you will be able to select the effect.

7-3. Rotate the **TIME/VALUE dial** to select the effect you wish to use. For this example, select an effect such as "C10=MTK:Mixdown."



7-4. After selecting the effect, press **[ENT/YES]**.

8. Press **STATUS ([1]-[6])** of the tracks that you wish to mixdown to let the STATUS indicators light green.

9. Press **[PLAY]**. The song will play back.

10. Adjust the overall volume of the song.

10-1. Press **[LEVEL/BALANCE]**.

10-2. Rotate the **TIME/VALUE dial** to adjust the **MasterLevel**.

11. Adjust the volume balance of each track. At this time, the volume that is being output to the MIX bus (recording level, pan) will be recorded without further change on the mastering tracks. It is best to set the volume as high as possible without allowing the sound to distort.

11-1. Press **[SHIFT] + [TR MIX (EXT SYNC)]**. (Track Mixer)

11-2. Press **[SHIFT] + [Level (TAP)]**.

11-3. Press **[SHIFT] + [1]-[6]**.

11-4. Rotate the **TIME/VALUE dial** to adjust the **MixLevel**.

12. When you finish adjusting the volume, press **[STOP]**. The song will stop.
The present signal flow (routing) is shown below.

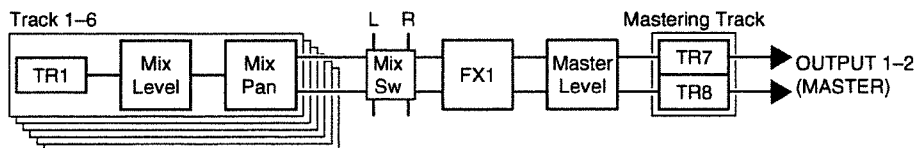

13. Press **[PLAY(DISPLAY)]**.

14. Move to the time location at which you wish to begin the mixdown (e.g., 00h00m00s00f).

15. Press **[REC]**. The REC indicator will light in red.

16. Press **[PLAY]**. The PLAY indicator will light in green, and recording will begin.

MEMO

The sound that has passed through **MasterLevel** will be recorded on the mastering tracks. In order to record with the highest quality, you should normally set this at **100**.

Add Finishing Touches to Your Song

17. When you finish recording, press [STOP].
18. Press [SHIFT] + [CD-RW]. The mastering room will be turned off (Play condition).

■ Playing back the mastering tracks

Here's how you can verify the result that was mixed down to the mastering tracks. Tracks 1-6 will not be played back.

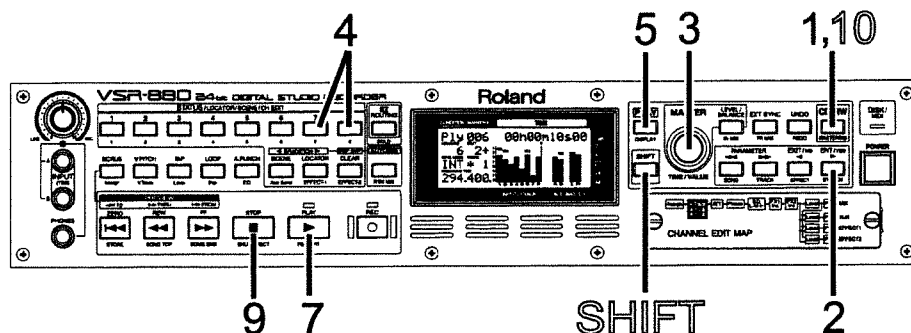

When you turn **CDR RecMode** (CDR recording mode) "On," the mastering tracks can be played back only using the following procedure. They cannot be played back in Play condition.

1. Press [CD-RW] several times until "CDR Mastering Room ?" appears in the display.
2. Press [ENT/YES]. "MasteringSw=" appears in the display.
3. Rotate the **TIME/VALUE dial** to select "On." The CD-RW indicator blinks, indicating that the Mastering Room is on.
4. Press **STATUS** ([7] or [8]). The STATUS indicators will light green. (**MasStatus (mastering track status)** = "Play") The present signal flow (routing) is shown below.

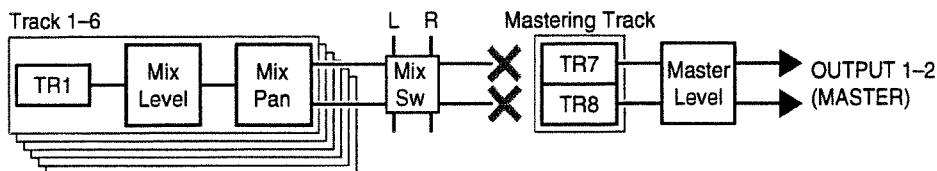

5. Press [PLAY (DISPLAY)].
6. Move to the location at which you started the mixdown.
7. Press [PLAY]. The mastering tracks will play back.
8. Adjust the volume of the Mastering Track.
 - 8-1. Press [LEVEL/BALANCE].
 - 8-2. Rotate the **TIME/VALUE dial** to adjust the **MasterLevel**.
9. When playback ends, press [STOP].
10. PRESS [SHIFT] + [CD-RW]. The mastering room will be turned off (Play condition).

Erasing an Unwanted Portion (Track Cut)

Song data that was track-bounced will be recorded to the CD-R disc starting from "00h00m00s00" of that track and ending at the end of the song (song end). This means that if there are silent portions at the beginning or end of the performance, the capacity of the CD-R disc will be wasted. To avoid this, you can erase unwanted portions.

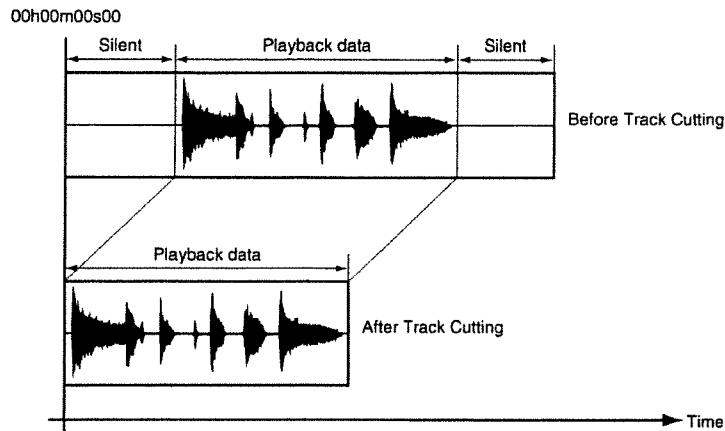

NOTE

When you execute Track Cut, the performance data will appear to have disappeared. However, the performance data that was cut will not actually be erased from the hard disk. This means that even if you execute Track Cut, the available recording time will not increase. If you wish to increase the available recording time, please read "If "Disk Full!" appears in the display (Song Optimize)" (p. 49).

Selecting the Portion that will be Written to the CD-R Disc

To simplify the task of assembling the track cuts, you can select a desired area, and register it in the Locator function. For details on registering/deleting Locator entries, refer to "Storing a Time Location" (Owner's Manual).

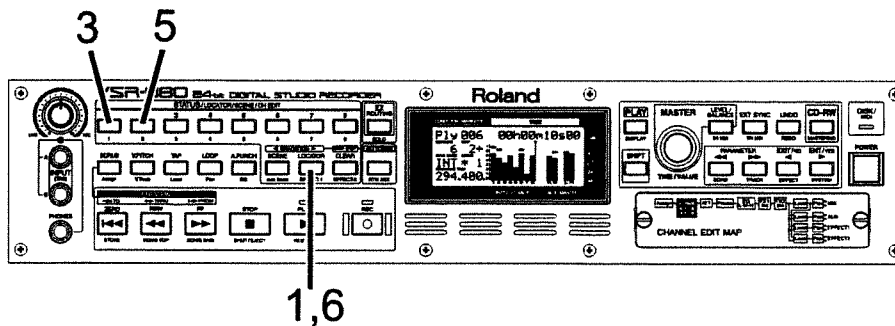

1. Press [LOCATOR]. The LOCATOR indicator will light.
2. Move to the time location where you wish to begin writing by using the transport control buttons, etc.
3. Press [1]. The time will be registered in locator 1.
4. Move to the time location where you wish to stop writing by using the transport control buttons, etc.
5. Press [2]. The time will be registered in locator 2.
6. Press [LOCATOR] again. The LOCATOR indicator will go dark.

Add Finishing Touches to Your Song

■ Deleting an Unwanted Portion At the End of the Song

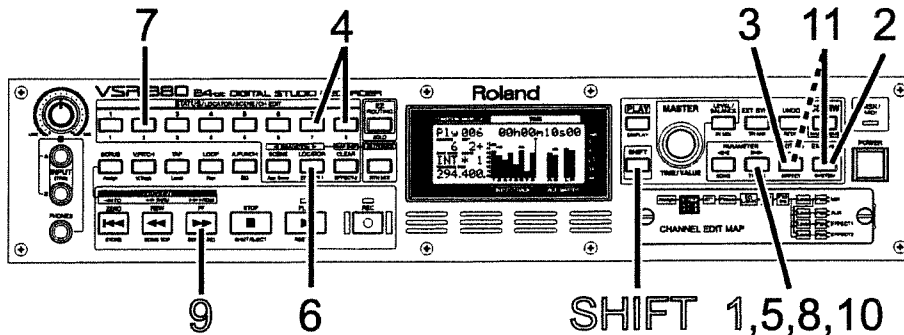

1. Press **[SHIFT] + [TRACK (▶▶)]** several times until "TRK Track Cut?" appears in the display.
2. Press **[ENT/YES]**.
3. Press **[◀]** several times until "TRK Cut Tr.=?-?" appears in the display.
4. Press **STATUS** (here, [7] or [8]) for the track on which you want to carry out Track Cut. The STATUS indicator will blink red.
5. Press **PARAMETER [▶▶]** several times until "TRK St=" appears in the display.
6. Press **[LOCATOR]**. The LOCATOR indicator will light.
7. Specify the starting time of the segment to be cut. Press **[2]**.
8. Press **PARAMETER [▶▶]**. "TRK End=" appears in the display.
9. Specify the ending time of the segment to be cut. Press **[SHIFT] + [SONG END (FF)]**.
10. Press **PARAMETER [▶▶]**. "TRK Track Cut OK?" appears in the display.
11. Press **[ENT/YES]**. This executes Track Cut. If you wish to cancel, press **[EXIT/NO]**.
12. When the cut is completed correctly, "Complete" appears in the display, and return to Play condition.

MEMO

At step 4, the function of **STATUS** will be to select the tracks for track editing.

MEMO

At step 7, the function of **STATUS** will be to recall the locator time ([2] = the time where writing to the CD-R disc ended).

MEMO

By accessing the Play List display (press **[SHIFT] + [DISPLAY (PLAY)]** several times), you can check the area to be cut.

■ Deleting an Unwanted Portion At the Beginning of the Song

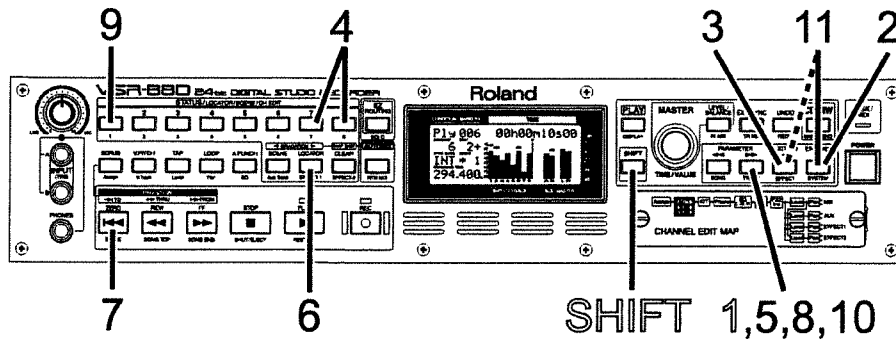

1. Press [**SHIFT**] + [**TRACK (▶▶)**] several times until "TRK Track Cut ?" appears in the display.
2. Press [**ENT/YES**].
3. Press [**◀**] several times until "TRK Cut Tr.=?-?" appears in the display.
4. Press **STATUS** (here, [7] or [8]) for the track on which you want to carry out Track Cut. The STATUS indicator will blink red.
5. Press **PARAMETER** [▶▶] several times until "TRK St=" appears in the display.
6. Press [**LOCATOR**]. The LOVATOR indicator will light.
7. Specify the starting time of the segment to be cut. Press [**ZERO**].
8. Press **PARAMETER** [▶▶]. "TRK End=" appears in the display.
9. Specify the ending time of the segment to be cut. Press [**1**].
10. Press **PARAMETER** [▶▶] "TRK Track Cut OK ?" appears in the display.
11. Press [**ENT/YES**]. This executes Track Cut. If you wish to cancel, press [**EXIT/NO**].
12. When the cut is completed correctly, "Complete" appears in the display, and return to Play condition.

MEMO

At step 4, the function of **STATUS** will be to select the tracks for track editing.

MEMO

At step 9, the function of **STATUS** will be to recall the locator time ([1] = the time where writing to the CD-R disc started).

MEMO

By accessing the Play List display (press [**SHIFT**] + [**DISPLAY (PLAY)**] several times), you can check the area to be cut.

Add Finishing Touches to Your Song

Adding Track Number Markers

By placing two or more songs one after the other in the same track, you can write these songs consecutively to the CD-R disc. In this case, you can place markers between songs to function as track numbers, just as on a pre-recorded audio CD. These track numbers will be written to the audio CD that you record on your CD-RW drive.

- The first track number marker is created automatically at the beginning of the song (00h00m00s00). Audio CD specifications require that a song be at least four seconds in duration. For this reason, track number markers must be placed four seconds apart. If you attempt to place a marker within four seconds of another marker, "Can't Set Marker" will be displayed and the marker will not be placed.
- Audio CD standards allow up to 99 songs to be stored on one disc. Furthermore, even if no track number marker is set at the beginning of the song, it is still used for the beginning of the first song. Thus, you can set up to 98 markers as track numbers.

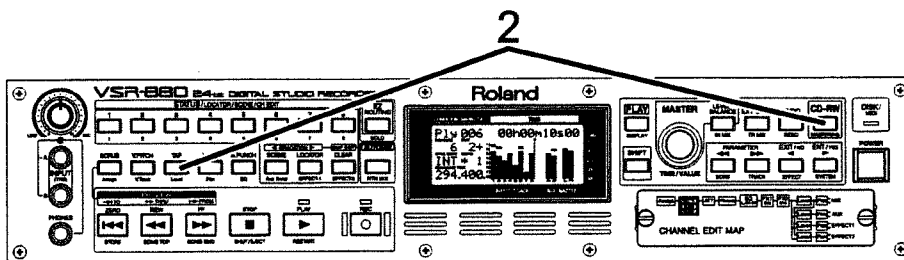
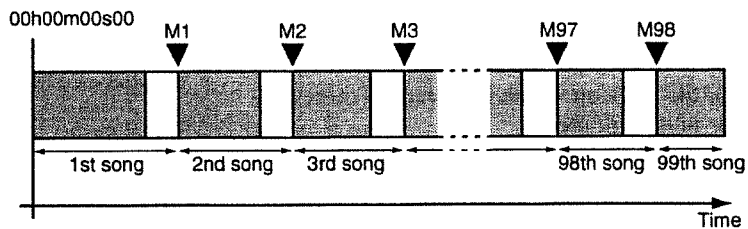

1. While listening to the song, move to the location where you wish to place a track number by using the transport control buttons, etc. You will probably find it convenient to use the Preview function or the Scrub function (Owner's Manual "Basic Operation").
2. Hold down **[CD-RW (MASTERING)]** and press **[TAP]**. A track number marker will be placed at the current time location.

■ Assigning Track Numbers

When you write an audio CD, a track number will automatically be assigned to "00h00m00s00f." For this reason, the track number markers and the actual song order will be as follows.

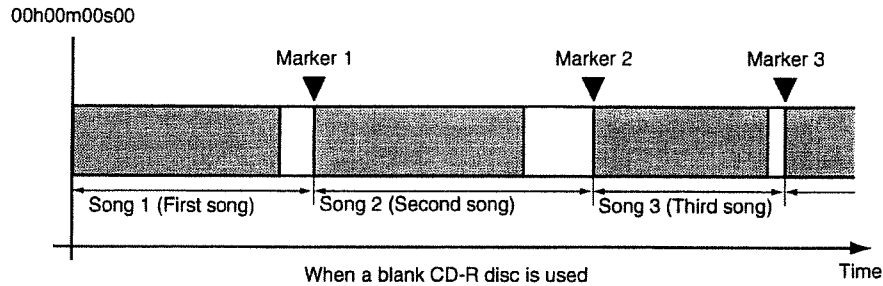

If you write additional songs onto a CD-R disc to which songs have already been written, track numbers will be assigned in sequence to follow the previously-written songs. For example if five songs have already been written to the CD-R disc, the next song you write will be song number six.

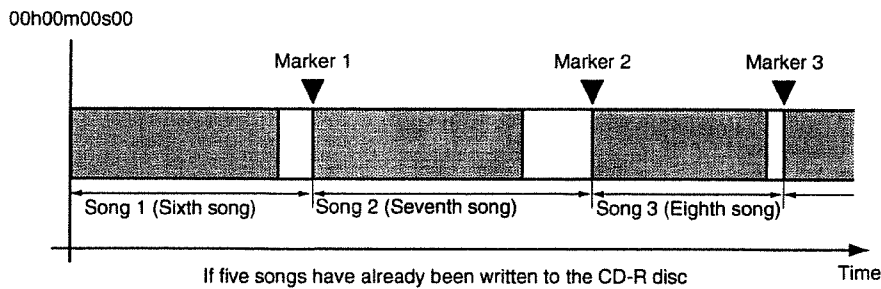

Creating an Original Audio CD (CD-R Write)

This chapter explains how you can create an original audio CD by recording two tracks (stereo tracks) from the VSR-880 to the Roland CD recorder.

Connecting the CD-RW Drive

A CD-RW drive allows you to use CD-R or CD-RW discs to create audio CDs. CD-R discs are the preferred format for audio CDs.

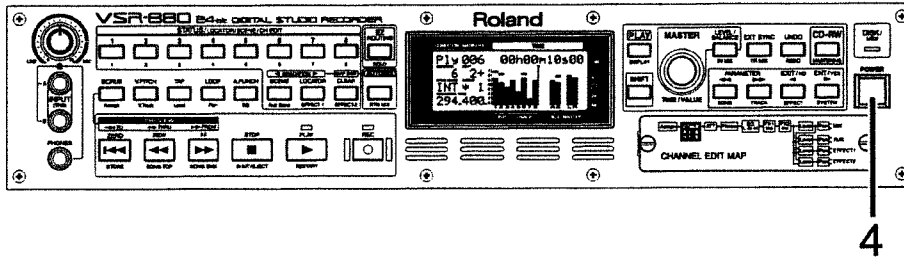

In order to create an original audio CD, you will need the Roland CD recorder (sold separately).

1. Make sure that the power of all devices is turned off.
2. Use a SCSI cable to connect the Roland CD recorder.

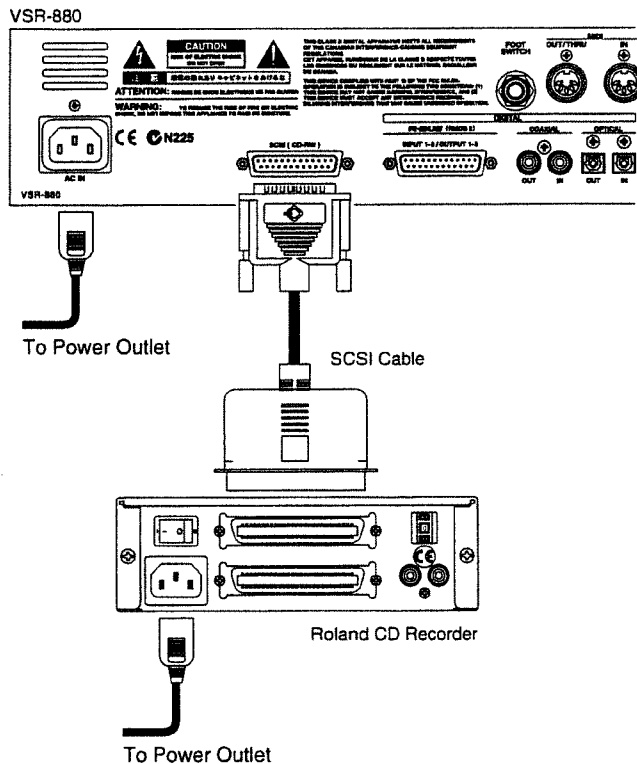

3. Turn on the power of the Roland CD recorder.
4. Turn on the power of the VSR-880.

Creating an Original Audio CD (CD-R Write)

Creating an Audio CD (CD-R Write)

When this procedure is performed, the VSR-880 will first create a CD-R image file on its internal hard disk, and will then write that image file to the CD-R disc. For this reason, there must be sufficient free space on the internal hard disk to create this image file.

All unused capacity of the hard disk will be allocated to the image file, regardless of the partition settings. The image file will be deleted automatically after it has been written to the CD-R disc.

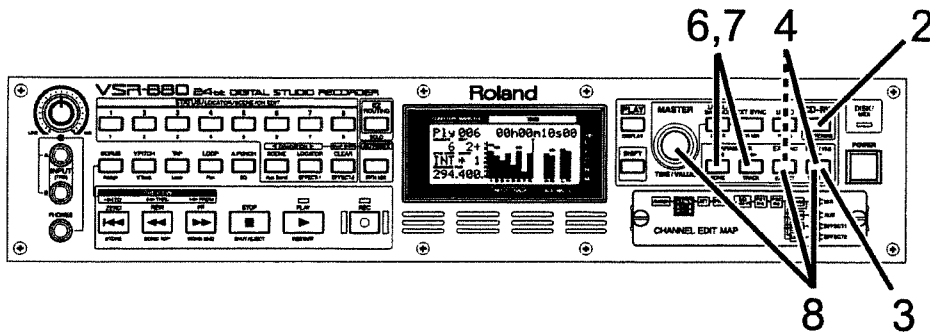

1. Place a blank CD-R disc in the Roland CD Recorder.
2. Press **[CD-RW]** several times until "CDR CD-R Write ?" appears in the display.
3. Press **[ENT/YES]**. "STORE Current?" appears in the display.
4. If you wish to save the current song, press **[ENT/YES]**; if not, press **[EXIT/NO]**. **If you have selected a demo song, then press [EXIT/NO].**
5. The VSR-880 displays the SCSI ID number of the connected CD recorder for a set time.
6. Then "Disc at Once?" or "Track at Once?" appears in the display. Press **PARAMETER [◀◀]** or **[▶▶]** to select how the data will be written, and press **[ENT/YES]**.

Disc at Once

The song data and the track number markers attached to the song data will be written to the CD-R disc without change. However, additional song data cannot be added later to a CD-R disc that was written using Disc At Once. (It will be in the same condition as if Finalize had been performed.)

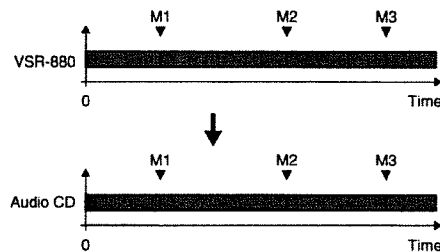

MEMO

If you have selected "CDR" as the **Record Mode** (recording mode) (p. 24), or if you have turned the **CDR RecMode** (CDR recording mode) setting "On" (p. 82), the step of creating the image data file will be omitted.

NOTE

Audio CD's created using a CD-RW disc cannot be played (heard) on a conventional CD player. Please use a CD-R disc for this example.

Creating an Original Audio CD (CD-R Write)

Creating an Original Audio CD (CD-R Write)

Track at Once

Two seconds of silence will automatically be written to the CD-R disc before each track number marker attached to the song data. (This is the same condition as when additional songs are written to the disc later.) Additional song data can be written to a CD-R disc that was written using Track at Once.

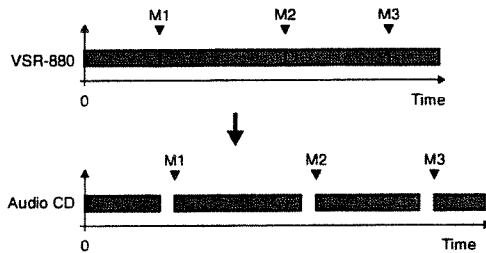

7. If you select "Track at Once," press **PARAMETER** [◀] or [▶] to select whether or not the finalize is carried out, press **[ENT/YES]**. A **TOC** (Table Of Contents) will be written so that the audio CD created by the VSR-880 can be played back on a standard CD player. It is not possible to write additional data to an audio CD that has been finalized.

Write + Finalize ?: Write the song, and then finalize.

Write w/o Fin. ?: Write only the song, and do not finalize.

Finalize ?: Only finalize without writing the song. Select this if you have inserted a CD-R disc to which you have already written songs, but which has not yet been finalized.

8. Use [◀] or [▶] and **TIME/VALUE** dial to select the tracks on the CD-R disc to which you want the song written.

Disk space occupied by a song when written to a disc (27MB)

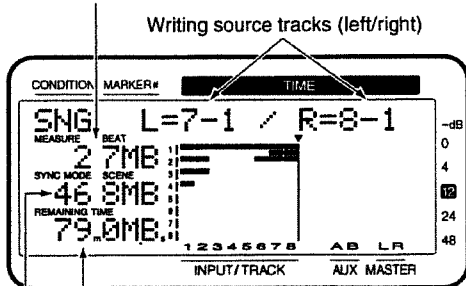

CD-R disc free space (790MB)

Internal hard disk free space (468MB)

MEMO

For example, if you have assigned track numbers to a medley of songs, Disc at Once would be the appropriate choice. This is because Track at Once would add approximately two seconds of silence, which would cause the playback to sound fragmented.

NOTE

If you use the CD-RW disc, you cannot choose "Track at Once" upon writing.

?

TOC (Owner's Manual; "Glossary")

MEMO

You can also press **[SHIFT] + STATUS ([1]-[8])** to select the writing tracks as an alternative to using the **TIME/VALUE** dial.

Creating an Original Audio CD (CD-R Write)

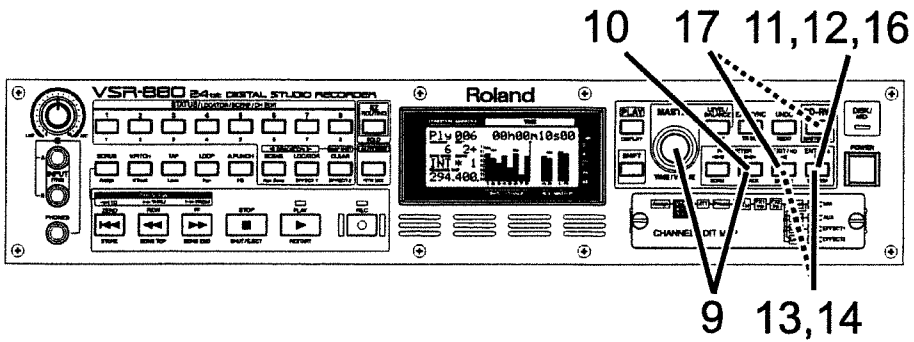

- 9. Press **PARAMETER** [▶▶]. "CD Speed" appears in the display. Use **TIME/VALUE** dial to select the speed at which the song will be written to the CD-R disc.

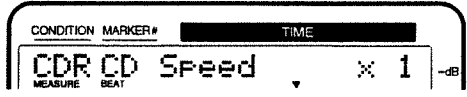

- CD Speed**
- x 1: The song will be written at normal speed. This will provide higher reliability.
 - x 2: The song will be written at double speed.
 - x 4: The song will be written at fourfold speed.

- 10. Press **PARAMETER** [▶▶]. A confirmation message appears in the display.
- 11. Press **[ENT/YES]**. "CDR CD Track No. OK?" is displayed.
- 12. Press **[ENT/YES]**. "Obey Copyrights?" is displayed.
- 13. Carefully read the License Agreement (detailed on the back cover of this manual); if you agree to the terms, press **[ENT/YES]**.
- 14. Writing to the CD-R disc begins. If you do not agree to the terms, press **[EXIT/NO]**. The VSR-880 just returns to the condition at Step 2.
- 15. After the write procedure has been carried out normally, "Write Another?" appears in the display.
- 16. When you want to write the same song information to another CD-R disc, insert another disc in the CD-RW drive and press **[ENT/YES]**. Repeat Steps 10–14. Press **[EXIT/NO]** to return to the condition at Step 2.
- 17. Press **[EXIT/NO]**. This returns you to the status at Step 2. Pressing **[CD-RW]** also returns you to Step 2.

MEMO

With some CD-R discs, the data may not be written correctly if you select "x2." In this case, select "x1." However, if a CD-RW disc is inserted into the CD-RW drive, select "x2."

MEMO

If no performance data has been recorded on the tracks to be written, the display will indicate "No Data to Write." Press **[ENT/YES]** to return to step 1.

Creating an Original Audio CD (CD-R Write)

Auditioning (Test Listening) Songs Written to CDs (CD Player Function)

You cannot playback CD-RW discs or CD-R discs that have just had written songs to them with regular commercial CD players. To listen to songs that have been just written to a disc in order to check them, carry out the following operation.

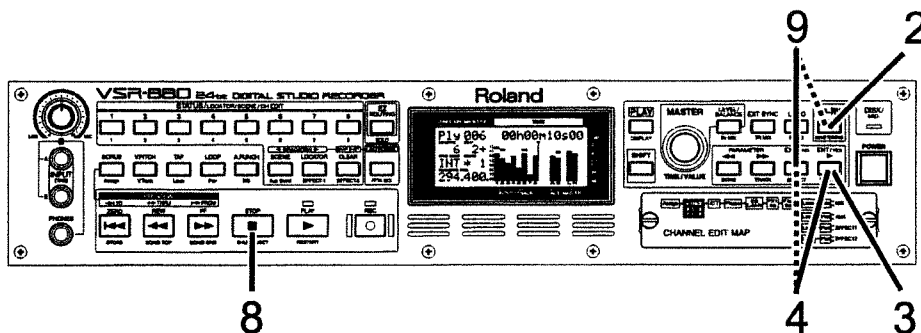

1. Insert the CD-R disc or commercial CD software onto the CD recorder.
2. Press [CD-RW] until "CDR CD Player?" appears in the display.
3. Press [ENT/YES]. "STORE Current?" (Store the current song?) appears in the display.
4. If you wish to save the current song, press [ENT/YES]; if not, press [EXIT/NO]. If you have selected a demo song, then press [EXIT/NO].
5. The VSR-880 displays the SCSI ID number of the connected CD recorder for a set time.
6. The CD-R disc information is then displayed.

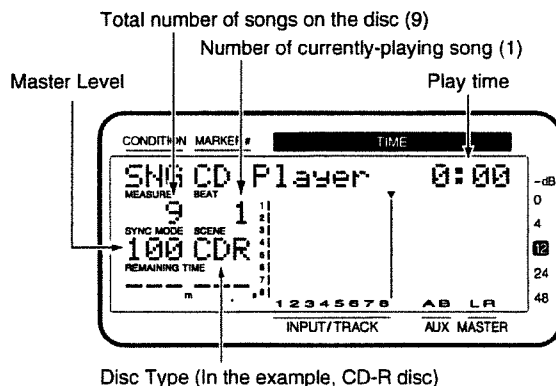

7. Only the following buttons, knobs, and faders effect the sound. Try listening to the contents of the disc.

[ZERO]:	Goes to the start of the first song.
[REW]:	Rapidly rewinds as long as the button is held down. (while stops)
[FF]:	Rapidly advances as long as the button is held down. (while stops)
[STOP]:	Stops the CD.
[PLAY]:	Begins playing back from the present location.
[◀◀]:	Returns to the previous song.
[▶▶]:	Advances to the next song.
PHONES Knob:	Adjusts headphone volume.
TIME/VALUE dial:	Adjusts the MasterLevel .

NOTE

Audio data written to a CD-RW disc cannot be played back on a conventional CD player. In such cases, you can listen to the data using the VSR-880's CD Player function.

NOTE

You can listen to the contents of the disc through the VSR-880's MONITOR jacks or the PHONES jack. You cannot output the contents through the CD-R drive's PHONES jack or AUDIO OUT jacks.

NOTE

Buttons and knobs response may be slow, but this does not indicate any malfunction. For example, expect to wait about five seconds after pressing [PLAY] or [◀◀] before you hear sound.

NOTE

Transport control buttons are used in controlling the CD control. They are not controls for the VSR-880's songs. Furthermore, the content of the CD currently listened to cannot be recorded by the VSR-880.

Creating an Original Audio CD (CD-R Write)



When listening to discs that have not been finalized, the last approximately 0.5 seconds of the song cannot be played back. Finalizing makes this portion audible.

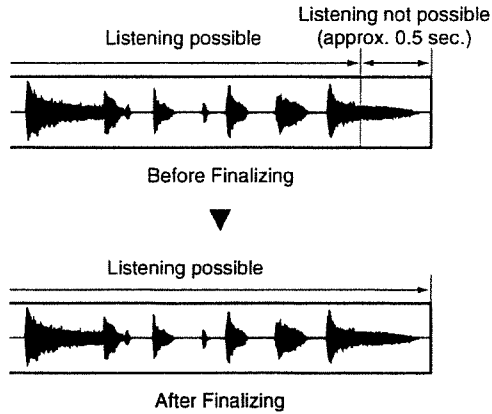

8. When you are finished listening to the material, press **[STOP]**.
9. Press **[EXIT/NO]**. This returns you to the status at Step 2. Pressing **[CD-RW]** also returns you to Step 2.

Saving Songs to CD-RW Discs

You can save song data stored on the VSR-880's hard disk to CD-RW discs. This procedure is called **backup**. Conversely, the process of loading backed up song data onto the internal hard disk is referred to as **recover**. Besides all V-track performance data, backed up data also includes Locator, Marker, and Scene settings made in the songs.

If you have finished writing a song to an audio CD and have no immediate need for the data, you can back up the data and then initialize the hard disk in order to free up more recording time.

Backup the song (CD-RW backup)

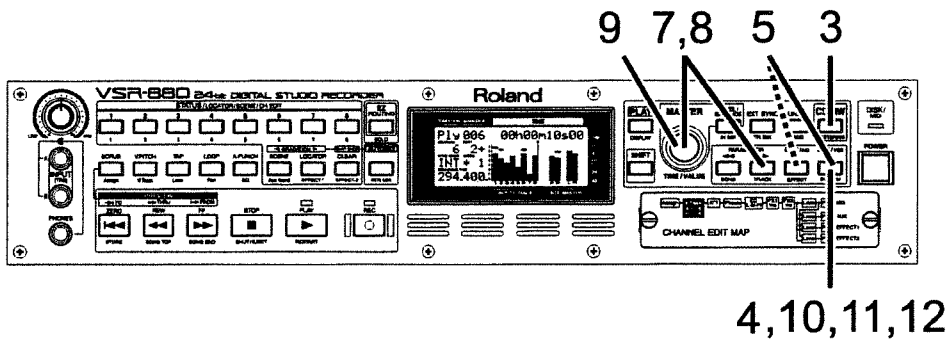

1. Select the disk (internal IDE hard disk) containing the source song you want to back up as the current drive.
2. Place a CD-RW disc in the Roland CD recorder.
3. Press **[CD-RW]** several times until "CD-R Backup?" appears in the display.
4. Press **[ENT/YES]**. "STORE Current?" (Store the current song?) appears in the display.
5. If you wish to save the current song, press **[ENT/YES]**; if not, then press **[EXIT/NO]**. If you have selected a demo song, then press **[EXIT/NO]**.
6. The VSR-880 displays the SCSI ID number of the connected CD recorder for a set time.
7. Then "CDR Bak=" appears in the display. Use the **TIME/VALUE** dial to select the song (only one song or all songs on the current drive) that you wish to save. To backup all songs from the current drive, select "All."



It is impossible to save any additional song data to the CD-RW discs or the CD-R discs that already have songs backed up on them. When you back up onto the CD-RW discs, existing contents should be totally erased before the new contents are saved.

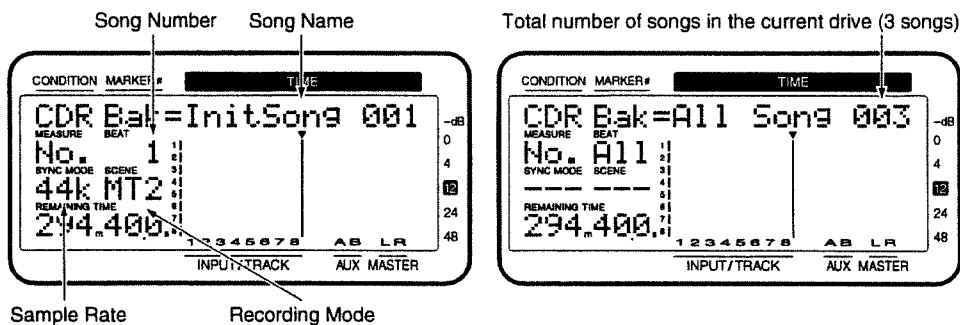

8. "+Verify=" appears in the display. Rotate the **TIME/VALUE dial** to select "On" or "Off," and press **PARAMETER [▶▶]**.

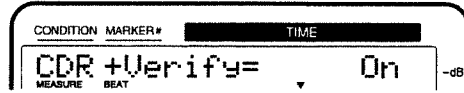

+Verify

If this is turned "On," verification will be performed after the song data has been backed up, to check whether or not the data was saved correctly.

9. "CD Speed=" appears in the display. Rotate the **TIME/VALUE dial** to select the backup speed (x1, x2 and x4).



Depending on the disc, it may not be possible to back up reliably to a CD-R disc with a setting of "x2." In such cases, select "x1." Also, if you insert a CD-RW disc into a CD-RW drive, select "x2."

10. Press **[ENT/YES]**. CD-R backup function will begin.
11. If the song holds a large amount of data, and cannot be contained on a single CD-RW disc, the disc is ejected, and the message "Insert Blank #" (# indicates the number in the order of insertion) appears in the display to check the total amount of necessary discs. Insert the next CD-RW disc and press **[ENT/YES]**. At this time, we recommend that you write the disc numbers on the labels so that you can keep track of the order in which the discs were inserted into the drive.
12. When copying over multiple CD-RW discs, "Insert Blank #" (# indicates the number in the order of insertion) appears in the display. Insert each of the discs once more in the proper order and press **[ENT/YES]**.
13. When the CD-R backup procedure is finished, return to Play condition.

NOTE

If as a result of the "+Verify" operation you receive a warning that the song data was not written correctly, please make a backup on another disk.

MEMO

When backing up to a CD-R, we recommend that you also execute +Verify to check whether the data was backed up correctly. Since +Verify checks the entire CD-RW disc, the operation will take a certain amount of time.

Saving Songs to CD-RW Discs

Loading Songs From CD-RW Discs (CD-RW recover)

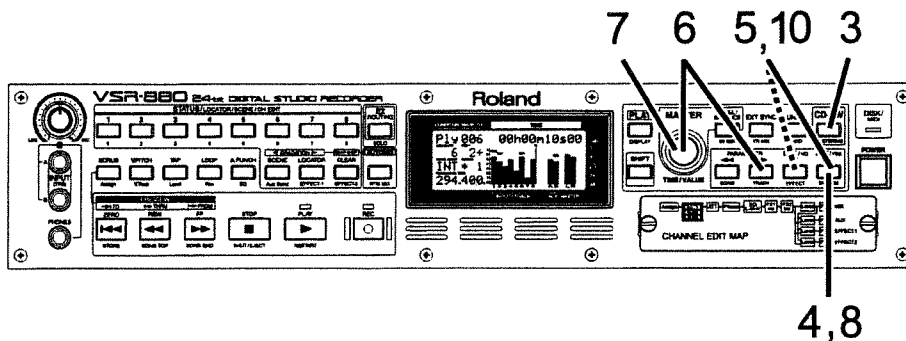

1. Select the disk (internal IDE hard disk) containing the song you want to load as the current drive.
2. Place the CD-RW disc to which the song data has been backed up in the Roland CD recorder.
3. Press **[CD-RW]** several times until "CD-R Recover ?" appears in the display.
4. Press **[ENT/YES]**. "STORE Current?" (Store the current song?) appears in the display.
5. If you wish to save the current song, press **[ENT/YES]**; if not, then press **[EXIT/NO]**. **If you have selected a demo song, then press [EXIT/NO].**
6. "CDR Rcv=" appears in the display. Use the TIME/VALUE dial to select the song (only one song or all songs on the CD-RW disc) that you wish to load. To recover all songs from the current drive, select "All."



Depending on the disc, it may not be possible to recover reliably from some CD-R discs at speeds of "x20" or "x8." In this case, select "x1." Even if the "CD Speed" is set to "x20" or "x8" the time it takes for recovery is not always 1/2 or 1/6 of the base. This is because writing to the internal hard disk can take a lot of time, or disc read errors can sometimes occur.

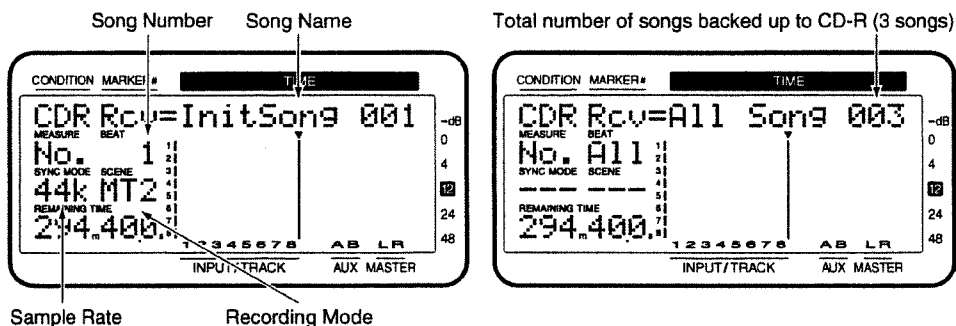

7. "CD Speed=" appears in the display. Rotate the TIME/VALUE dial to select the recover speed (x1, x4, x8 and x20).

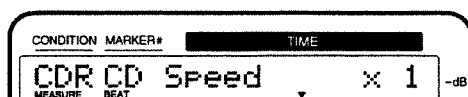

8. Press **[ENT/YES]**.

9. If you selected "All" in step 6, the display will indicate "INIT ***.* OK ?" (OK to initialize the disk drive?). "***.*" is the ID number and partition number of the recover destination disk drive. For example when recovering to partition 0 of the internal hard disk drive, the display would indicate "IDE:0."
10. If you wish to initialize the current drive and then recover, press [ENT/YES]. If at this point you press [ENT/YES], all songs saved on the internal hard disk will be lost. If you decide not to initialize, press [EXIT/NO]. Normally you should press [EXIT/NO].
11. Execute the load. When over multiple discs, the disc is ejected, "Insert Disc #" (# indicates the number in the order of insertion) appears in the display. Insert the next disc and press [ENT/YES].
12. When the CD-R recover procedure is finished, return to Play condition.

How to Erase the Data in the CD-RW Disc

It is impossible to write audio data to the CD-R discs in which the song data is saved. To write audio data to the finalized CD-RW discs, erase the existing data as follows.

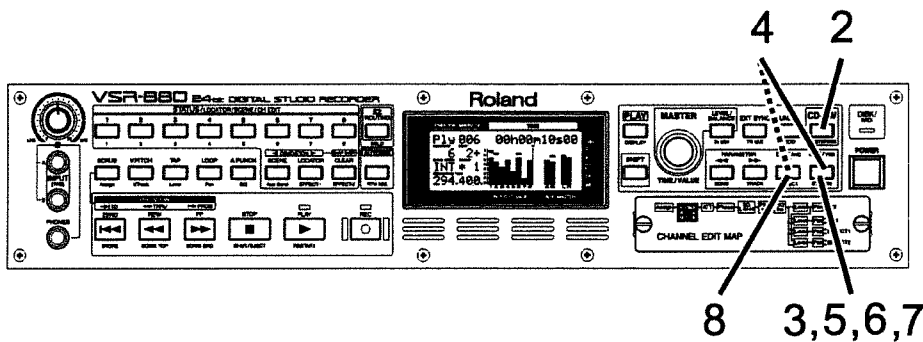

1. Place the CD-RW disc which includes the data you wish to erase in the CD-RW drive.
2. Press [CD-RW] several times until "CD-R Backup?" appears in the display.
3. Press [ENT/YES] and "STORE Current?" appears.
4. Press [ENT/YES] to save the current song, or [EXIT/NO] if not. If the current song is the demo song, press [EXIT/NO]. "CDR Bak=" appears in the display.
5. Press [ENT/YES] and "Finalized CD!" or "Not Blank CD!" appears.
6. Press [ENT/YES] and "CD-RW Erase?" appears.
7. Press [ENT/YES] and "CD-RW Erasing..." appears and the contents in the CD-RW disc is erased.
8. "Continue?" appears and press [EXIT/NO].

Appendices

Deleting Unneeded Songs (Song Erase)

After creating audio CD's or backing up songs to a CD-RW disc etc., you may wish to delete unneeded songs from the hard disk. **This operation cannot be undone by the Undo function.**

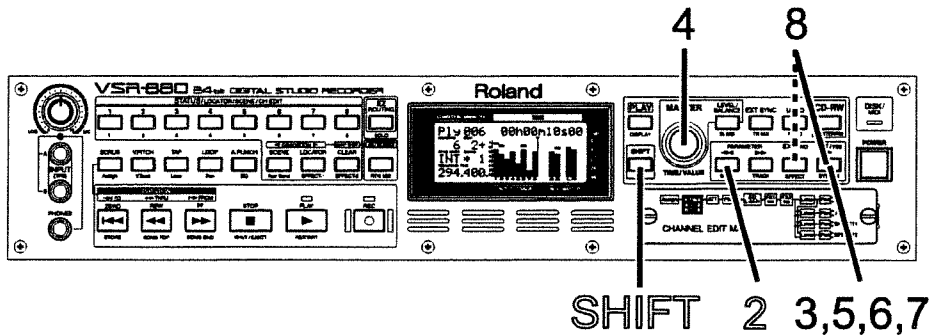

MEMO

If the current song has been erased, the lowest-numbered song in the current drive will be selected as the current song.

1. Select the drive contains the song you want to erase as the current drive. (p. 26)
2. Press **[SHIFT] + [SONG]** several times until "SNG Song Erase?" appears in the display.
3. Press **[ENT/YES]**. The names of the songs stored on the current drive will appear. An asterisk "*" will appear at the beginning of the current song.
4. Rotate the **TIME/VALUE** dial to select the song that you wish to erase.

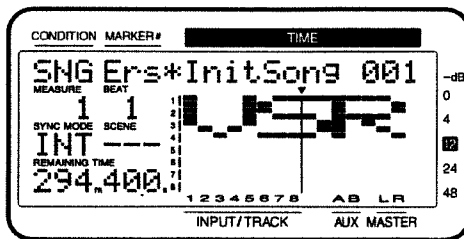

5. Press **[ENT/YES]**. "Erase Song Sure?" appears in the display.
6. Press **[ENT/YES]** again. "EraseReallySure?" appears in the display.
7. Press **[ENT/YES]** again. "STORE Current?" appears in the display.
8. If you wish to save the current song, press **[ENT/YES]**; if not, then press **[EXIT/NO]**. **If you have selected a demo song, then press [EXIT/NO].**
9. When the song has been erased, return to Play condition.

Confirming That a Drive is Not Damaged (Drive Check)

You can check the drive you are using to make sure it can be read correctly. This is referred to as **Drive Check**.

This provides a way to determine whether a failure during Song Copy (Owner's Manual "Song Condition") or CD-R Backup (p. 96) is due to a problem in the song itself that was saved on disk, whether the problem is with the connections, or if there is a problem of some other kind. If data cannot be read correctly, the display will indicate the song in which the error occurred.

1. Press **[SHIFT] + [SYSTEM (▶)]** several times until "SYS Drive Check ?" appears in the display.
2. Press **[ENT/YES]**.
3. Rotate the **TIME/VALUE dial** to select the drive that you wish to check.

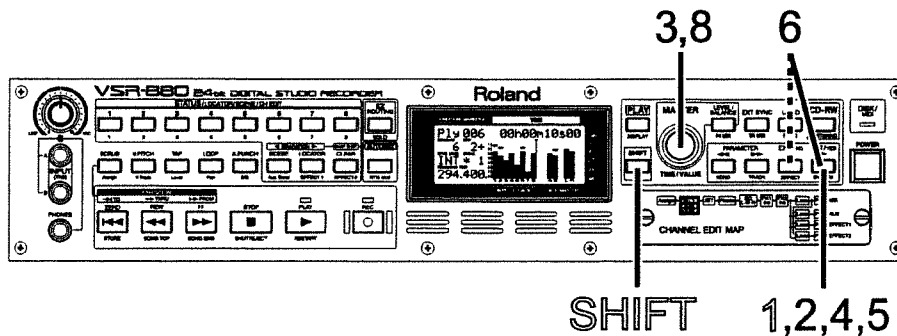

4. Press **[ENT/YES]**. A confirmation message ask you that you want to proceed with the Drive Check appears in the display.
5. Press **[ENT/YES]** again. "STORE Current?" appears in the display.
6. If you wish to save the current song, press **[ENT/YES]**; if not, then press **[EXIT/NO]**. **If you have selected a demo song, then press [EXIT/NO].**
7. Drive Check is the executed. Progress of the operation is shown in the display. **Do not turn off the power until the operation is completed.**

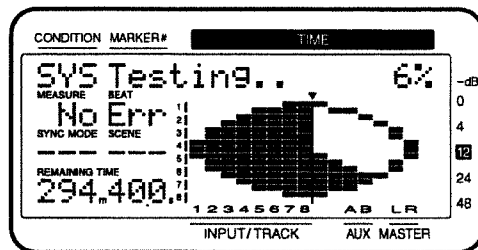

8. When Drive Check is completed, the display screen appears as shown below.

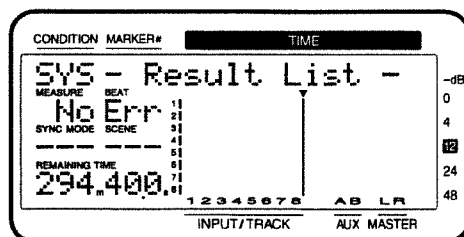

MEMO

You can use the following procedure to cancel the Drive Check.

1. Press **[EXIT/NO]**. "Cancel?" appears in the display.
2. Press **[ENT/YES]**. Drive Check is canceled.

Appendices

■ If the display indicates “No Err”

The entire disk could be read correctly. Press [ENT/YES]. Return to Play condition.

■ If the display indicates “___ Err”

The underlines portion will display the number of times that a read error occurred. Rotate the **TIME/VALUE dial** to check the list. The display will indicate “Err” for locations where an error was found. Locations for which “OK” was displayed have no problems.

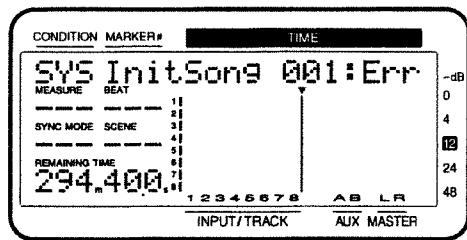

ResultList (Drive check results)

System: Location where basic data used by the VSR-880 for recording and playback is stored

SongList: Location where the saved songs are managed

InitSong001: Each song (in actual use, the song name is displayed)

InitSong002:

:

InitSong 200:

ClusterInfo. (Cluster information)

Total: Number of clusters on the entire disk

Defect: Number of clusters tagged as unusable memory

Used: Number of clusters currently being used

Free: Number of clusters currently not being used

X-LinkErr: Number of cross-linked clusters

LooseArea: Number of clusters whose links are lost

IllegalDIR: Number of directories with incorrect content

ReadError: Number of read errors detected by this operation

If a disk error is found, it is possible to erase only the data that was lost as a result of the error (Recover). I.e., the disk can be restored to a correct operating condition while keeping as much possible of the non-error data.

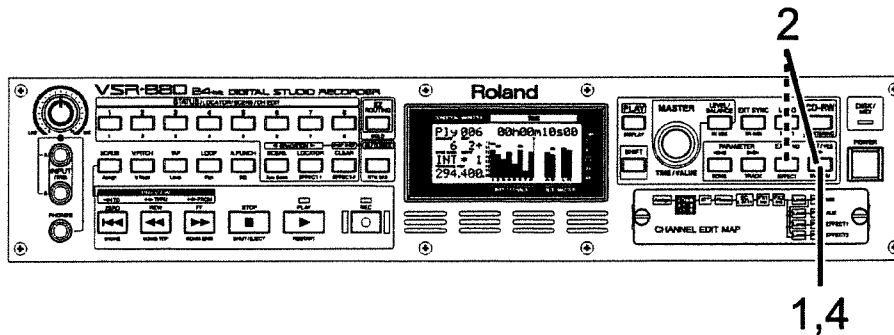

1. Press **PARAMETER** [▶▶]. "RecoverDriveTry?" appears in the display.
2. The message "You'll Lose Data" will appear in the display. Press **[ENT/YES]**. The Recover operation is executed. If you want to cancel the operation, press **[EXIT/NO]**.
3. When the recovery is finished, the results are shown on the display screen. Songs that have been partially altered are indicated by "Adj"; deleted songs are indicated by "Del." Songs that have not been changed are not indicated. Please check the display.

RecoverResult (Recovery result)

InitSong001:
 InitSong003: Modified songs (in actual operation, the song name)
 :
 InitSong200:

ClusterInfo. (Cluster information)

Total: Number of clusters on the entire disk
 Defect: Number of clusters marked as unusable memory
 Used: Number of clusters currently being used
 Free: Number of clusters currently unused

4. Press **[ENT/YES]**. Return to Play condition.



This procedure does not correct the disk error. All error locations will be erased. This means that depending on the location in which the error occurred, a take that was recorded may no longer be playable, auto mix data may be lost, or even the entire song itself may be erased. If the error has occurred in the system or song list, the probability of this danger is especially high.

Clusters

These are the smallest unit of memory that the VSR-880 uses to manage data on a disk drive. The smallest physical units on a disk drive are called either sectors or blocks, and depending on the device, the size that is handled can be selected. For example, the VSR-880 is designed to use disks with 512 bytes/sector. When the VSR-880 manages song data, it handles 64 sectors as a single unit (cluster). This means that $512 \text{ (bytes)} \times 64 \text{ (sectors)} = 32768 \text{ bytes (32 kilobytes)}$ is one cluster.

Cross Link

This is an error in which a cluster is detected as being included in two or more songs. In such a case, a completely different song may be heard in the middle of a song. Such an error condition is referred to as a cross link.

Loose Areas

An error in which clusters not included in any song are detected as containing valid data. In this case, the VSR-880 will not store data in those clusters. A situation which causes this error to occur is called a loose area.

Directories

The VSR-880 stores data such as audio data or parameter values on disk in units called files. In order to manage large numbers of files, the VSR-880 keeps lists of file names and the locations on disk in which the data of these files is stored. These lists are called directories.

The "IllegalDIR" message will appear when this list is incorrect. For example, this message will appear if the data of a certain file is supposed to be recorded in an area of the disk which does not actually exist, or if the list itself becomes permanently unreadable.

Change partitions (Drive Select)

Each partition on the VSR-880's disk drive is treated as an independent drive, with each partition automatically given a partition number (0-9). When a single hard disk has multiple partitions, you can specify which partition of which drive will be used. This disk drive partition currently used is referred to as the **current drive**.

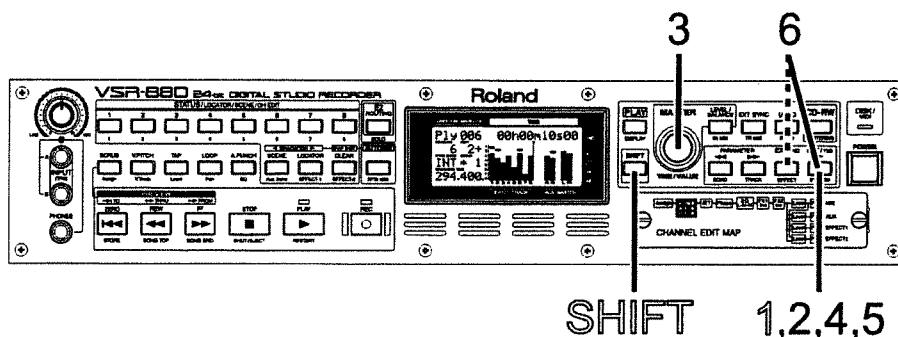

1. Press **[SHIFT] + [SYSTEM (▶)]** several times until "SYS Drive Select" appears in the display.
2. Press **[ENT/YES]**.
3. Rotate the **TIME/VALUE dial** to select the disk drive to which you want to change. The internal hard disk will be shown as "IDE," and external disk drives will be shown as "SC0-SC7." The number following each disk drive indicates the partition number. For example if you wish to switch to the Zip drive, select "SC5:0."

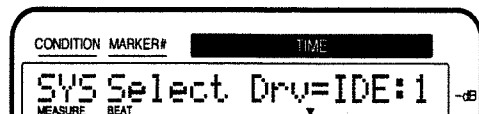

4. Press **[ENT/YES]** again. A confirmation message appears on the screen.
5. Press **[ENT/YES]** again. "STORE Current?" (Store the current song?) appears in the display.
6. If you wish to save the current song, press **[ENT/YES]**; if not, then press **[EXIT/NO]**. **If you have selected a demo song, then press [EXIT/NO].**
7. After you have switched the current drive, return to Play condition.

MEMO

The VSR-880 accepts installation of Internal hard disks (designated by Roland). For simultaneous recording or playback of a number of tracks, for getting more out of the available hard disk space, and in order to get the fullest performance in general from the VSR-880, we recommend using the 2.1 GB or larger Internal Hard Disk.

NOTE

If you wish to use hard disks or song data on both the VSR-880 and the VS-880/880EX/1680, because of factors such as differing partition sizes and numbers of tracks, there will be limitations as to what you can do. For more detailed information, please see "Compatibility" (Owner's Manual).

Initializing the Disk (Drive Initialize)

When the hard disk is initialized, the entire contents of the disk will be erased. Make sure that the hard disk does not contain data you need to keep. If necessary, back up the data to the Roland CD recorder, etc.

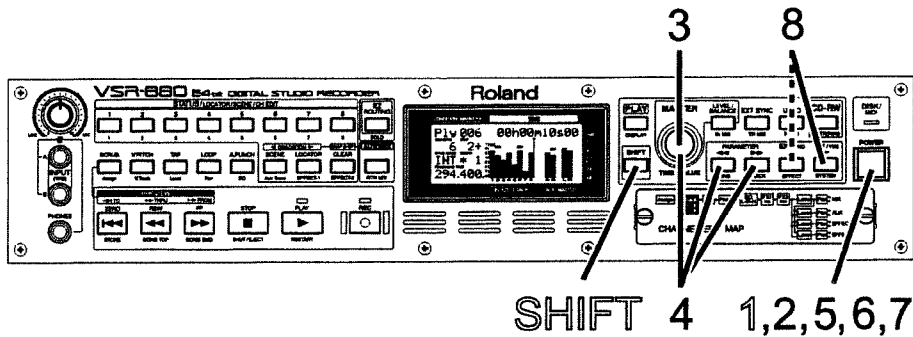

1. Press **[SHIFT] + [SYSTEM (▶)]** several times until "SYS DriveInitialize" appears in the display.
2. Press **[ENT/YES]**. "Init.Drive=" appears in the display.
3. Rotate the **TIME/VALUE** dial to select the disk drive to which you want to initialize.

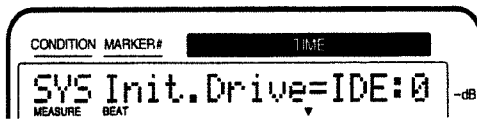

Init Drive (Initialize Drive)

Select the disk drive (IDE, SCSI0-SCSI7). "The internal hard disk will be shown as "IDE," and external disk drives will be shown as "SC0-SC7." The number following each disk drive indicates the partition number.

4. As needed, use **PARAMETER [◀]** or **[▶]** and the **TIME/VALUE** dial to make the following settings.

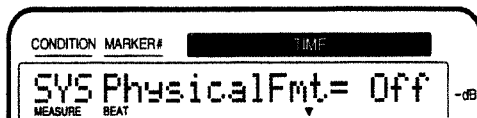

Physical Fmt (Physical Format)

Select whether or not to use physical formatting. In normal circumstances, set this to "Off." If a disk error is found with **Surface Scan** (p. 108), set this to "On," then initialize the hard disk again.

NOTE

If you accidentally delete data that you need, that data cannot be restored to its previous condition. Roland Corporation assumes no liability concerning such loss of data.

NOTE

When a single hard disk or other disk is divided into partitions, it is not possible to initialize only an individual partition. The Drive Initialize operation will be performed on all partitions of that disk drive or other disk.

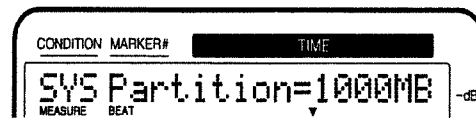

Partition

Select the partition size (500 MB or 1000 MB). In normal circumstances, select "1000 MB."



Surface Scan

This confirms that the read and write functions in all of the disk drive's partitions are operating correctly when the drive is initialized. In normal circumstances, set this to "On."

5. Press **[ENT/YES]**. "SYS Init.***:* OK ?" appears in the display. "***:*" refers to the drive's SCSI ID number. For example, "IDE:0" indicates a internal hard disk.
6. Press **[ENT/YES]** again. "SYS Init.***:*, Sure ?" (Really initialize the disk?) appears in the display.
7. Press **[ENT/YES]** again. "STORE Current?" (Store the current song?) appears in the display.
8. If you wish to save the current song, press **[ENT/YES]**; if not, then press **[EXIT/NO]**. **If you have selected a demo song, then press [EXIT/NO].**
9. After the initialization is completed correctly, the VSR-880 restarts automatically, and return to Play condition.

NOTE

Be aware that initializing a drive requires some time. This is not a malfunction. For example, when physical formatting is turned on, the time required to format one Zip disk is approximately 10 minutes. The progress of initialization will be shown in the display. Be sure not to turn the power off until initialization is complete.

■ Checking Disk Reliability (Surface Scan)

When initializing a hard disk or other disk, you can confirm that the read and write functions in all of the disk partitions are operating correctly. This is referred to as **Surface Scan**.

When Surface Scan is performed, it will require somewhat more time to initialize the drive, but the reliability of the hard disk will be enhanced. We recommend that you also perform Surface Scan when you initialize a drive.

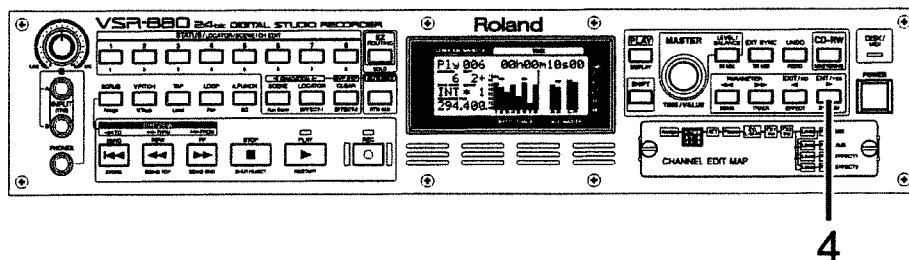

1. Set Surface Scan to "On," and as described in "Initializing the Disk" (p. 106), carry out the Drive Initialize procedure.
2. After initialization of the disk is completed, Surface Scan begins automatically.
3. When Surface Scan is completed, one of the following messages appears in the display.

"File System Err"

A read or write failure has occurred in a location which stores basic data used by the VSR-880 for recording and playback. This disk drive cannot be used by the VSR-880.

"___ Defect"

The underlined portion will indicate the number of unusable memory locations in this drive. The larger this number is, the lower the reliability of this drive.

"— Complete —"

This drive has no unusable memory.

4. Press [ENT/YES]. VSR-880 will restart.

Canceling Surface Scan

You may cancel Surface Scan by performing the following procedure.

1. Press [EXIT/NO]. "Cancel?" appears in the display.
2. Press [ENT/YES]. Surface Scan is now canceled. However, the memory found to be unusable up to that point is not registered.
3. The VSR-880 restarts automatically.



Performing this procedure deletes all contents saved on the disk. Conduct this check when initializing newly purchased disks or disks which previously have been used with a personal computer or other device. Be sure to make a backup copy of any disk you are presently using on the VSR-880 before carrying out the procedure on it.



If there are any places on the disk where the reading or writing of data cannot be performed, the VSR-880 registers this as unusable memory. Recording and playback then become unavailable at that location.



The Surface Scan procedure takes a certain amount of time. Be aware that Surface Scan requires some time. This is not a malfunction. For example, the time required to conduct Surface Scan on one Zip disk (100 MB) is approximately 10 minutes. The time it will take to conduct Surface Scan on your disk drive should be based on the size (capacity) of the disk. The progress of the Surface Scan procedure is shown in the display.

Index

- A**
- Adjusting
 - Input Sensitivity28, 54, 59
 - pan42
 - recording sensitivity28
 - Tone43
 - ALESIS adat14
 - analog output jacks18
 - Assign30, 56
 - Audio
 - Audio CD90
 - AUDIO CH54
- B**
- backup96
- C**
- CD player5, 38
 - CD Player Function94
 - CD-R Write90
 - CD-RW96
 - backup96
 - recover98
 - CD-RW drive5
 - Clock
 - master39, 53
 - reference39, 53
 - Coaxial38
 - compressor81
- D**
- Demo Song18
 - Digital Signals38
 - Direct Out18
 - Disc at Once91
 - Disk Full!49
 - Drive
 - Check101
 - Initialize106
 - Select105
- E**
- Effect
 - effects62
 - Effects Expansion Board5, 7, 62
 - Insertion-Type71
 - electric guitar5
 - EQ
 - EQ Sel43
 - EQH45
 - EQL44
 - EQM44
 - Equalizer
 - 2-band43
 - 3-band43
 - Equalizer Select43
 - High45
 - Low44
 - Mid44
 - Mid Gain44
 - parametric equalizer43, 81
 - Erase100
- F**
- finalize92
 - Front Panel28
- G**
- Guitar Multi71
- H**
- Hard Disk6, 23
 - HDP88 series5-6
 - headphones5
- I**
- IDE5
 - Input
 - INPUT A/B58
 - input jack58
 - INPUT knob59
- L**
- level meter29
 - Locator85
- M**
- Markers88
 - master clock39
 - Mastering81
 - Mastering Room81
 - Mastering Tool Kit81
 - Mic Simulator71
 - Mix Level29
 - monitor speakers15
- N**
- Name27
 - New23
- O**
- Optical38
 - Optimize49

Index

- OUTPUT jacks18
Overdubbing36, 60
- P**
Partition Size23
peaking44
PLAY condition15
Playing Back
 mastering tracks84
 Performance You Recorded32, 58
power amps15
Power cable5
Preview88
Protect51
Punch-In47
Punch-Out47
- R**
R-BUS53
RCA phono type18
Recorders
 DAT38
 MD38
Recording30, 56
recover96
Redo46
reference clock39
Remaining Time45
- S**
Scrub88
Select26
Send/Return62
Song
 Song Erase100
 Song Name27
 Song New23
 Song Optimize49
 Song Protect51
 Song Select26
 Song Store50
Store50
Surface Scan108
synthesizer5
- T**
TASCAM DA14
Test Listening94
Track
 Track Bouncing77
 Track Cut85
 Track at Once92
 Track Erase48
 TRS type phone jacks58
- U**
Undo46
- V**
Verify97
VM-
 3100Pro5, 12-13, 53
 7200/71005, 12-13
 C7200/C71005
V-Mixing
 Consoles5
 Processors5
 Station5
Vocal Multi71
VS8F-25, 7, 62
VSR-8805
V-Track33
 Switching V-Track Bank35
 Switching V-Tracks33

VSR-880 Connecting the VM-3100Pro

With the Roland V-Mixing Station **VM-3100Pro** (version 1.03 or later), you can use the following “**VSR-880 Control Function**” when you connect the **VSR-880** via **R-BUS (RMDB2)**. Version number of the VM-3100Pro will be shown in the display when you turn the power on.

Before you use “VSR-880 Control Function”

1. Please **update** the system of your VM-3100Pro to the latest version.
 - Please contact your nearest Roland Service Center or authorized Roland distributor in your country about how to update.
 - You can use the special SMF (Standard MIDI File) to update the VM-3100Pro. For the download of the SMF and the procedure to update, please refer to the Roland international website.

Roland international website: <http://www.roland.co.jp/>
2. Before you use “VSR-880 Control Function,” please set the VM-3100Pro and the VSR-880 as follows. For more detailed information, please read the respective **Owner’s Manual** or **leaflet** about the setting of each unit.

VSR-880 Settings

SYSTEM PRM	MasterCik	R-BUS
SYSTEM MIDI	MID:DeviceID	17
	MID:MMC	Off/RBUS
Sync/Tempo	Syn:Source	INT
	Syn:InSel	R-BUS
	Syn:Gen.	R-BUS
	Syn:MTC Type	30
Masterblock	Direct Out	On

VM-3100Pro Settings

SYSTEM PREF	MasterCik	INTERNAL
	LocatorType	TIMECODE
	RecorderType	HD
SYSTEM MIDI	DeviceID	17
	TimingMon.	TIMECODE
	TC Fmt	30ND
Transport		RECORDER



To prevent malfunction and/or damage to speakers or other devices, always turn down the volume before making connections.

How to change the playback time of the VSR-880 with the VALUE dial

1. While holding [**SHIFT**], press [**LEVEL METER (BIG TC)**]. (Big Time Code display)
2. Rotate the **VALUE dial**, and the playback time of the VSR-880 changes.



Locate operation with the **VALUE dial** is possible only in the Big Time Code display.

How to scrub the track of the VSR-880

1. While holding [**SHIFT**], press [**LEVEL METER (BIG TC)**]. (Big Time Code display)
2. Hold down [] until “ScrubON:TR1” (Scrubbing Track1) appears in the display. Scrub preview of the Track1 of the VSR-880 starts.

By turning the **VALUE dial** while scrubbing, you can change the current time.
By pressing [**SELECT**] of channels 1 to 8 while scrubbing, you can switch the track to scrub preview.
3. Press [] again, and scrub preview stops.



Scrub preview is possible only in the Big Time Code display page. While scrub previewing, [**SELECT**], [**AUDIO CH**] and [**MIDI CH**] cannot be used.

VSR-880 Connecting the VM-3100Pro

How to select the VSR-880 songs

* *To prevent malfunction and/or damage to speakers or other devices, set the master fader and the channel faders 13–20 to the lowest position.*

1. Press [LEVEL METER].
2. Press [F1-F4 ON/OFF], and the functions appears in the display.
3. Press [F3 (MTR)], and the recording track select page appears in the display.
4. Press [F1-F4 ON/OFF], and the functions appears in the display.
5. Press [F4 (SONG)], and the VSR-880 Song Select page appears in the display.



6. Rotate the **VALUE** dial and highlight the song to be loaded on the VSR-880.
7. Press [ENTER/YES], and “Select Song Sure?” message appears in the display.
8. Press [ENTER/YES], and “Store Current?” message appears in the display.
9. If you wish to store the current song, press [ENTER/YES]; If not, press [EXIT/NO]. “Processing..” message appears in the display and the song switches on the VSR-880.

NOTE

You cannot select a song which is not 44.1 kHz. If you select a song which is not 44.1 kHz and press [ENTER/YES], “Can’t Execute. (Not 44k Song.)” message appears in the display.

MEMO

To update the song list displayed, press [F1 (SCAN)]. To abort the operation, press [EXIT/NO]. “Can’t Execute. (No Response.)” message appears in the display.

How to store the current song on the VSR-880

* *To prevent malfunction and/or damage to speakers or other devices, set the master fader and the channel faders 13–20 to the lowest position.*

1. While holding [SHIFT], press [], “STORE Current?” message appears in the display.
2. If you wish to store the current song, press [ENTER/YES]; If not, press [EXIT/NO]. “Processing..” message appears in the display and the current song on the VSR-880 is stored.

MEMO

To abort the operation, press [EXIT/NO]. “Can’t Execute. (No Response.)” message appears in the display.

Other VSR-880 Control Functions

You can also use the following functions on the VM-3100Pro in combination with the VSR-880.

- Locator (VM-3100Pro Owner’s Manual p. 56)
- RMDB2 related functions (VM-3100Pro Owner’s Manual p. 58)

Information

When you need repair service, call your nearest Roland Service Center or authorized Roland distributor in your country as shown below.

AFRICA

EGYPT

Al Fanny Trading Office
P.O. Box 2904,
El Horrieh Heliopolos, Cairo,
EGYPT
TEL: (02) 4185531

REUNION

Maison FO - YAM Marcel
25 Rue Jules Mermet
Chaudron - BP79 97491
Ste Clotilde REUNION
TEL: 28 29 16

SOUTH AFRICA

**That Other Music Shop
(PTY) Ltd.**
11 Melle Street (Cnr Melle and
Juta Street)
Braamfontein 2001
Republic of SOUTH AFRICA
TEL: (011) 403 4105

Paul Bothner (PTY) Ltd.
17 Werdmuller Centre Claremont
7700
Republic of SOUTH AFRICA

P.O. Box 23032
Claremont, Cape Town
SOUTH AFRICA, 7735
TEL: (021) 64 4030

ASIA

CHINA

**Beijing Xinghai Musical
Instruments Co., Ltd.**
6 Huangmchang Chao Yang
District, Beijing, CHINA
TEL: (010) 6774 7491

HONG KONG

**Tom Lee Music Co., Ltd.
Service Division**
22-32 Pun Shan Street, Tsuen
Wan, New Territories,
HONG KONG
TEL: 2415 0911

INDIA

Rivera Digitec (India) Pvt. Ltd.
409, Nirman Kendra Mahalaxmi
Flats Compound Off. Dr. Edwin
Moses Road, Mumbai-400011,
INDIA
TEL: (022) 498 3079

INDONESIA

PT Citra Inti Rama
Jl. Cideng Timur No. 15J-150
Jakarta Pusat
INDONESIA
TEL: (021) 6324170

KOREA

**Cosmos Corporation
Service Station**
261 2nd Floor Nak-Won Arcade
Jong-Ro ku, Seoul, KOREA
TEL: (02) 742 8844

MALAYSIA

Bentley Music SDN BHD
140 & 142, Jalan Bukit Bintang
55100 Kuala Lumpur, MALAYSIA
TEL: (03) 2443333

PHILIPPINES

G.A. Yupangco & Co. Inc.
339 Gil J. Puyat Avenue
Makati, Metro Manila 1200,
PHILIPPINES
TEL: (02) 899 9801

SINGAPORE

Swee Lee Company
150 Sims Drive,
SINGAPORE 387381
TEL: 748-1669

CRISTOFORI MUSIC PTE LTD

Blk 3014, Bedok Industrial Park E,
#02-2148, SINGAPORE 489980
TEL: 243 9555

TAIWAN

**ROLAND TAIWAN
ENTERPRISE CO., LTD.**
Room 5, 9th Fl. No. 112 Chung Shan
N.Road Sec2, Taipei, TAIWAN,
R.O.C.
TEL: (02) 2561 3339

THAILAND

Theera Music Co., Ltd.
330 Verg NakornKasem, Soi 2,
Bangkok 10100, THAILAND
TEL: (02) 2248821

VIETNAM

Saigon Music
138 Tran Quang Khai St.,
District 1
Ho Chi Minh City
VIETNAM
TEL: (08) 844-4068

AUSTRALIA/ NEW ZEALAND

AUSTRALIA

**Roland Corporation
Australia Pty., Ltd.**
38 Campbell Avenue
Dee Why West. NSW 2099
AUSTRALIA
TEL: (02) 9982 8266

NEW ZEALAND

Roland Corporation (NZ) Ltd.
97 Mt. Eden Road, Mt. Eden,
Auckland 3, NEW ZEALAND
TEL: (09) 3098 715

CENTRAL/LATIN AMERICA

ARGENTINA

Instrumentos Musicales S.A.
Florida 656 2nd Floor
Office Number 206A
Buenos Aires
ARGENTINA, CP1005
TEL: (54-11) 4-393-6057

BRAZIL

Roland Brasil Ltda.
R. Coronel Octaviano da Silveira
203 05522-010
Sao Paulo BRAZIL
TEL: (011) 3743 9377

CHILE

Comercial Fancy S.A.
Avenida Rancagua #0330
Providencia Santiago, CHILE
TEL: 56-2-373-9100

EL SALVADOR

OMNI MUSIC
75 Avenida Notre y Alameda
Juan Pablo 2 No. 4010
San Salvador, EL SALVADOR
TEL: (503) 262-0788

MEXICO

Casa Veerkamp, s.a. de c.v.
Av. Toluca No. 323 Col. Olivar de
los Padres 01780 Mexico D.F.
MEXICO
TEL: (525) 668 04 80

**La Casa Wagner de
Guadalajara s.a. de c.v.**
Av. Corona No. 202 S.J.
Guadalajara, Jalisco Mexico
C.P.44100 MEXICO
TEL: (3) 613 1414

PANAMA

Productos Superiores, S.A.
Apartado 655 - Panama 1
REP. DE PANAMA
TEL: (507) 270-2200

URUGUAY

Todo Musica
Cuareim 1488, Montevideo,
URUGUAY
TEL: 5982-924-2335

VENEZUELA

Musiland Digital C.A.
Av. Francisco de Miranda,
Centro Parque de Cristal, Nivel
C2 Local 20 Caracas
VENEZUELA
TEL: (02) 285 9218

EUROPE

AUSTRIA

Roland Austria GES.M.B.H.
Siemensstrasse 4, P.O. Box 74,
A-6063 RUM, AUSTRIA
TEL: (0512) 26 44 260

BELGIUM/HOLLAND/ LUXEMBOURG

Roland Benelux N. V.
Houtstraat 3 B-2260 Oevel
(Westerlo) BELGIUM
TEL: (039)16 575811

DENMARK

Roland Scandinavia A/S
Nordhavnsvej 7, Postbox 880
DK-2100 Copenhagen
DENMARK
TEL: (039)16 6200

FRANCE

Roland France SA
4, Rue Paul Henri SPAAK
Parc de l'Esplanade F 77 462 St
Thibault Lagny Cedex FRANCE
TEL: 01 600 73 500

FINLAND

**Roland Scandinavia As,
Filial Finland**
Lauttasareentie 54 B
Fin-00201 Helsinki, FINLAND
TEL: (9) 682 4020

GERMANY

**Roland Elektronische
Musikinstrumente
Handelsgesellschaft mbH.**
Oststrasse 96, 22844 Norderstedt,
GERMANY
TEL: (040) 52 60090

GREECE

STOLLAS S.A.
Music Sound Light
155, New National Road
26422 Patras, GREECE
TEL: 061-435400

HUNGARY

Intermusica Ltd.
Warehouse Area 'DEPO' P/83
H-2046 Torokbalint, HUNGARY
TEL: (23) 511011

IRELAND

Roland Ireland
Audio House, Belmont Court,
Donnybrook, Dublin 4,
Republic of IRELAND
TEL: (01) 2603501

ITALY

Roland Italy S. p. A.
Viale delle Industrie, 8
20020 Arese Milano, ITALY
TEL: (02) 937-78300

NORWAY

**Roland Scandinavia Avd.
Kontor Norge**
Lilleakerveien 2 Postboks 95
Lilleaker N-0216 Oslo
NORWAY
TEL: 273 0074

POLAND

P. P. H. Brzostowicz
UL. Gibraltarska 4,
PL-03664 Warszawa POLAND
TEL: (022) 679 44 19

PORTUGAL

**Tecnologias Musica e Audio,
Roland Portugal, S.A.**
RUA SANTA CATARINA
131 - 4000 Porto -PORTUGAL
TEL: (02) 208 44 56

ROMANIA

FBS LINES
Plata Libertatii 1,
RO-4200 Cheorgheni
TEL: (066) 164-609

RUSSIA

Slami Music Company
Sadovaya-Triumfalnaya st., 16
103006 Moscow, RUSSIA
TEL: 095 209 2193

SPAIN

**Roland Electronics
de España, S. A.**
Calle Bolivia 239 08020 Barcelona,
SPAIN
TEL: (93) 308 1000

SWEDEN

**Roland Scandinavia A/S
SWEDISH SALES OFFICE**
Danvik Center 28, 2 tr.
S-131 30 Nacka SWEDEN
TEL: (08) 702 0020

SWITZERLAND

**Roland (Switzerland) AG
Musitronic AG**
Gerberstrasse 5, CH-4410 Liestal,
SWITZERLAND
TEL: (061) 921 1615

UKRAINE

TIC-TAC
Mira Str. 19/108
P.O. Box 180
295400 Munkachevo, UKRAINE
TEL: (03131) 414-40

UNITED KINGDOM

Roland (U.K.) Ltd.
Atlantic Close, Swansea
Enterprise Park SWANSEA
SA7 9FJ,
UNITED KINGDOM
TEL: (01792) 700139

MIDDLE EAST

BAHRAIN

Moon Stores
Bab Al Bahrain Road,
P.O. Box 20077
State of BAHRAIN
TEL: 211 005

CYPRUS

Radex Sound Equipment Ltd.
17 Diagorou St., P.O. Box 2046,
Nicosia CYPRUS
TEL: (02) 453 426

ISRAEL

**Haliit P. Greenspoon &
Sons Ltd.**
8 Retzif Fa'aliya Hashnuya St.
Tel-Aviv-Yahv ISRAEL
TEL: (03) 6823666

JORDAN

AMMAN Trading Agency
Prince Mohammed St. P.O. Box
825 Amman 11118 JORDAN
TEL: (06) 4641200

KUWAIT

Easa Husain Al-Yousifi
P.O. Box 126 Safat 13002
KUWAIT
TEL: 5719499

LEBANON

A. Chahine & Fils
P.O. Box 16-5857 Gergi Zeidan St.
Chahine Building, Achrafieh
Beirut, LEBANON
TEL: (01) 335799

OMAN

**OHI Electronics & Trading
Co. LLC**
P.O. Box 889 Muscat
Sultanate of OMAN
TEL: 959085

QATAR

Badie Studio & Stores
P.O. Box 62,
DOHA QATAR
TEL: 423554

SAUDI ARABIA

**aDawlah Universal
Electronics APL**
P.O. Box 2154 ALKHOBAR 31952,
SAUDI ARABIA
TEL: (03) 898 2081

SYRIA

**Technical Light & Sound
Center**
Khaled Ibn Al Walid St.
P.O. Box 13520
Damascus - SYRIA
TEL: (011) 2235 384

TURKEY

**Barkat Muzik aletleri ithalat
ve ihracat limited ireketti**
Siraselviler Cad. Billurcu Sok.
Mucadelle Cikmeze No. 11-13
Taksim, Istanbul, TURKEY
TEL: (0212) 2499324

U.A.E.

**Zak Electronics & Musical
Instruments Co.**
Zabeel Road, Al Sherooq Bldg.,
No. 14, Grand Floor DUBAI
U.A.E.
P.O. Box 8050 DUBAI, U.A.E.
TEL: (04) 360715

NORTH AMERICA

CANADA

**Roland Canada Music Ltd.
(Head Office)**
5480 Parkwood Way Richmond
B. C., V6V 2M4 CANADA
TEL: (0604) 270 6626

Roland Canada Music Ltd.

(Toronto Office)
Unit 2, 109 Woodbine Downs
Blvd, Etobicoke, ON
M9W 6Y1 CANADA
TEL: (0416) 213 9707

U. S. A.

Roland Corporation U.S.
5100 S. Eastern Avenue
Los Angeles, CA 90040-2938,
U. S. A.
TEL: (323) 890 3700

Concerning Copyright

The law prohibits the unauthorized recording, public performance, broadcast, sale, or distribution etc. of a work (CD recording, video recording, broadcast, etc.) whose copyright is owned by a third party. Roland will take no responsibility for any infringement of copyright that you may commit in using the VSR-880.

About SCMS

The VSR-880 does not implement SCMS. This design decision was made with the intent that SCMS should not restrict the creation of original compositions which do not violate copyright law. Do not use this device in a way which would infringe on copyrights held by another.



SCMS (Owner's Manual "Glossary")

Disclaimer of liability

Roland will take no responsibility for any "direct damages," "consequential damages," or "any other damages" which may result from your use of the VSR-880. These damages may include but are not limited to the following events which can occur when using the VSR-880.

- Any loss of profit that may occur to you
- Permanent loss of your music or data
- Inability to continue using the VSR-880 itself or a connected device

About the License Agreement

The VSR-880 and its CD-R capability are designed to allow you to reproduce material to which you have copyright, or material which the copyright owner has granted you permission to copy. Accordingly, reproduction of music CDs or other copyrighted material without the permission of the copyright owner, other than for your own personal use and enjoyment (private use) constitutes copyright infringement, which may incur penalties. Consult a copyright specialist or special publications for more detailed information on obtaining such permission from copyright holders.

 Roland®

71456412

UPC

71456412



18991

Roland