

Roland®



# CD Writing Kit VS-CDRII

## OWNER'S MANUAL

Before using this unit, carefully read the sections entitled: "USING THE UNIT SAFELY" and "IMPORTANT NOTES" (p. 2, p. 3). These sections provide important information concerning the proper operation of the unit. To get the most from your VS-CDRII, read this *Owner's Manual* in its entirety. The manual should be saved and kept on hand as a convenient reference.

This manual primarily describes the operation of a VS-CDRII when used with a VS-880—VS-880 system software Ver.3.20A or higher is required. If you use a VS-880, refer to the VS-880 owner's manuals for additional information as needed. The VS-CDRII can also be used with the VS-1680 V-XPANDED and VS-880EX Ver.2.0 or later. Please update your VS-1680/880EX beforehand (p. 6), and refer its *Owner's Manual*. In addition, make sure to read "Introduction" in this manual.

### About the Conventions Used in This Owner's Manual

In order to clearly communicate all of the information it contains, this *Owner's Manual* makes use of the following conventions.

The names of buttons appear inside square brackets like these: [ ].

*Example:* [SONG] means the Song button.

The unit's buttons may have more than one function name printed next to them. This is because, with some of the buttons, their function changes if you hold down [SHIFT] as you press them. Others provide different functions depending on the mode you are in. For the sake of clarity, the names of both functions for a particular button are sometimes given in this manual, with the relevant function being listed first.

*Example:* [SOLO (EDIT)] refers to the Solo button.

Messages that appear in the VS-880's display are placed in quotes.

*Example:* When shutting down, "SHUT/EJECT?" appears in the display.

(p. \*\*) indicates a page to be referred to in this manual.

► indicates a page to be referred to in the *VS-880 Owner's Manual*.

Macintosh is a registered trademark of Apple Computer, Inc.

Omega is a registered trademark of Omega Corporation.

Zip is a trademark of Omega Corporation.

All product names mentioned in this document are trademarks or registered trademarks of their respective owners.



Copyright © 1999 ROLAND CORPORATION

All rights reserved. No part of this publication may be reproduced in any form without the written permission of ROLAND CORPORATION.







# USING THE UNIT SAFELY

## INSTRUCTIONS FOR THE PREVENTION OF FIRE, ELECTRIC SHOCK, OR INJURY TO PERSONS

### About WARNING and CAUTION Notices



 <b>WARNING</b>	Used for instructions intended to alert the user to the risk of death or severe injury should the unit be used improperly.
 <b>CAUTION</b>	Used for instructions intended to alert the user to the risk of injury or material damage should the unit be used improperly. * Material damage refers to damage or other adverse effects caused with respect to the home and all its furnishings, as well to domestic animals or pets.

### About the Symbols



	The  symbol alerts the user to important instructions or warnings. The specific meaning of the symbol is determined by the design contained within the triangle. In the case of the symbol at left, it is used for general cautions, warnings, or alerts to danger.
	The  symbol alerts the user to items that must never be carried out (are forbidden). The specific thing that must not be done is indicated by the design contained within the circle. In the case of the symbol at left, it means that the unit must never be disassembled.
	The  symbol alerts the user to things that must be carried out. The specific thing that must be done is indicated by the design contained within the circle. In the case of the symbol at left, it means that the power-cord plug must be unplugged from the outlet.

### ALWAYS OBSERVE THE FOLLOWING

#### WARNING

- Before using this unit, make sure to read the instructions below, and the *Owner's Manual*. 
- Do not open or perform any internal modifications on the unit. 
- Do not attempt to repair the unit, or replace parts within it (except when this manual provides specific instructions directing you to do so). Refer all servicing to your retailer, the nearest Roland Service Center, or an authorized Roland distributor, as listed on the "Information" page. 

#### WARNING

- In households with small children, an adult should provide supervision until the child is capable of following all the rules essential for the safe operation of the unit. 
- Protect the unit from strong impact. (Do not drop it!) 
- DO NOT play a CD-ROM disc on the CD-R drive. The resulting sound may be of a level that could cause permanent hearing loss. Damage to speakers or other system components may result. 

# Important notes



In addition to the items listed under "USING THE UNIT SAFELY" on p. 2, please read and observe the following precautions:

## Handling the CD-RW Drive

- Install the unit on a solid, level surface in an area free from vibration. If the unit must be installed at an angle, be sure the installation does not exceed the permissible range: upward, 5°; downward, 5°.
- Avoid using the unit immediately after it has been moved to a location with a level of humidity that is greatly different than its former location. Rapid changes in the environment can cause condensation to form inside the drive, which will adversely affect the operation of the drive and/or damage discs. When the unit has been moved, allow it to become accustomed to the new environment (this can take a few hours) before operating it.
- Remove any disc from the loading tray before powering up or down.
- When transporting the CD-RW drive, remove the disc from the loading tray. Also, avoid having the loading tray face downwards when carrying it.
- Do not knock, shake, or move the drive while the power to the unit is on.

## Handling CD-R Discs

- Please observe the following when handling discs:
  - Never touch the shiny underside (encoded surface) of the disc.
  - Do not use or store discs in dirty or dusty areas.
  - Do not subject discs to temperature extremes (e.g., direct sunlight in an enclosed vehicle). Recommended temperature range: 10 to 50° C (50 to 122° F).
- Put the disc back into its case for storage.
- Do not leave discs in the CD-RW drive for extended periods.
- Do not affix stickers, labels, or other such items to the face of discs.
- Avoid touching or scratching the shiny underside (encoded surface) of the disc. Doing so may result in the faulty reading and writing of data. Keep your discs clean using a commercially available CD cleaner.
- Using a soft, dry cloth, wipe the disc from the center to the outer rim. Do not wipe the disc about the center in a circular direction.
- Do not apply record cleaners or sprays, benzene, or other solvents.
- Avoid bending or twisting discs, as this can adversely affect them to extent that data can no longer be read from, or written to them. Device malfunction can be caused as well.

## Concerning Copyright

- The law prohibits the unauthorized recording, public performance, broadcast, sale, or distribution etc. of a work (CD recording, video recording, broadcast, etc.) whose copyright is owned by a third party.
- The VS series (VS-880/1680/880EX) does not use SCMS. This design decision was made with the intent that SCMS should not restrict the creation of original compositions which do not violate copyright law. Roland will take no responsibility for any infringement of copyright that you may commit in using the VS series.

### About SCMS

"SCMS" stands for "Serial Copy Management System." This is a system that protects the rights of copyright holders by prohibiting recording via a digital connection of more than one copy. When digital connections are made between digital recorders that implement this function, SCMS data will be recorded along with the audio data. Digital audio data that contains this SCMS data cannot again be recorded via a digital connection.

## Disclaimer of Liability

- Roland will take no responsibility for any direct damages, consequential damages, or any other damages which may result from your use of the VS series. These damages may include but are not limited to the following events which can occur when using the VS series.
  - Any loss of profit that may occur to you.
  - Permanent loss of your music or data.
  - Inability to continue using the VS series itself or a connected device.

# Contents



Before using this device, please carefully read "Concerning Copyright," "About SCMS," and "About the License Agreement" on page 54.

Important Notes.....	3
Introduction.....	6
Features.....	6
Checking Items Supplied.....	6
How to Read This <i>Owner's Manual</i> .....	7

## **Adding CD-R Capability to the VS-880 ..... 8**

Before Adding CD-R Capability.....	8
Required Items.....	8
About Disk Drives.....	8
About Songs.....	8
About Effects (With VS8F-1 Installed).....	8
Switching Between CD-R and DAT Use.....	8
Procedure for Adding CD-R Capability Using SMFs.....	9
Procedure for Adding CD-R Capability Using an External Zip Drive.....	9
Switching the system (SYSTEM A ↔ SYSTEM B).....	11

## **Basic Operation (Preparing Songs) ..... 13**

Before You Begin Recording.....	13
Items Necessary for Recording.....	13
Connecting the VS-880 to Audio Equipment.....	13
Turning On the Power.....	13
Creating New Songs (Song New).....	14
A General Overview of the Multitrack Recording Process.....	14
Connecting to Instruments.....	14
Sounding the Metronome.....	15
Preparing Tempo Maps.....	15
Making Metronome Settings.....	15
Recording Performances to Tracks.....	15
Recording with Reverb Effect Applied (Loop).....	16
Recording with Amp Simulator Applied (Insert).....	17
Recording to Separate Tracks (Overdubbing).....	18
Recording Over Mistakes Only (Punch-In/Out).....	18
To Record Digital Signals.....	19
Items Necessary for Digital Connections.....	19
Connecting to Digital Devices.....	19
To Digitally Connect CD Players.....	19
To Cancel a Digital Connection with a CD Player.....	20
Creating Master Data (Mix Down).....	20
Balancing the Tracks (Auto Mix).....	21
Adjusting the Tone (Equalizer).....	21
Adjusting Placement of the Sound (Level/Pan).....	21
Arranging Multiple Tracks in Stereo (Track Bouncing).....	22
Bouncing Tracks with Reverb Applied (Loop).....	22
Bouncing Tracks with Compression Applied (Insert).....	24
Deleting Unneeded Material (Track Cut).....	26
Selecting the Portions to Be Written to the CD-R Disc.....	26
Deleting Unneeded Material After the Performance.....	26
Deleting the Unneeded Material Before the Performance.....	27

<b>Making Original CDs .....</b>	<b>28</b>
Before Making an Original CD .....	28
Items Necessary for Preparing Original CDs .....	28
Connecting the CD-RW Drive .....	28
Making an Original CD (CD-R Write) .....	29
Writing Songs to CD-R Discs .....	29
Arranging and Writing Multiple Songs to Disc .....	29
Determining Song Boundaries (Track Number) .....	30
Creating silence between song (Disc at Once and Track Once) .....	31
Song writing procedure .....	32
Listening to the Song You Have Written (CD Player Mode) .....	35
Writing Additional Songs to the Disc .....	37
<b>Saving a song to a CD-RW disc .....</b>	<b>38</b>
Items Necessary for CD-R Backup .....	38
Saving Songs to CD-RW Discs (CD-R Backup) .....	39
Backup procedure .....	39
Restoring songs from a CD-RW disc (CD-R Recover) .....	41
Recovery procedure .....	41
<b>If You Are Using the VS-1680/VS-880EX .....</b>	<b>43</b>
<b>To Update the VS-1680 .....</b>	<b>44</b>
Updating Using SMFs .....	44
Using an Updater on a Zip Disk .....	45
<b>To Update the VS-880EX .....</b>	<b>48</b>
Updating Using SMFs .....	48
Using an Updater on a Zip Disk .....	49
<b>Appendices .....</b>	<b>52</b>
About SCSI .....	52
Troubleshooting .....	52
Q & A .....	52
List of Messages .....	54
Glossary/List of Terms .....	55
Index .....	56

<p><b>Requirements</b></p> <ul style="list-style-type: none"> <li>• For VS-880 CD-R operation, Ver.3.20A or later system software is required. (p. 8)</li> <li>• To make an original audio CD by VS series with VS-CDRII, the internal IDE Hard Disk (HDP88 series) is required. (p. 28)</li> </ul>
---

# Introduction

Congratulations on your purchase of the Roland VS-CDRII CD Writing Kit. VS-CDRII is a CD-RW drive for the Roland VS-Series recorders: VS-880/1680/880EX. With this drive, you can write your own original audio CDs and save your song data onto CD-R and CD-RW discs.

If you use a VS-1680 V-XPANDED and VS-880EX Ver.2.0 or later, you can connect the VS-CDRII to your unit now. Please refer to the respective *Owner's Manual* for additional information.

If you use a VS-1680 with a software version earlier than Ver.2.0, please update your VS-1680 by following the procedure "To Update the VS-1680" on p. 44.

If you use the VS-880EX with software earlier than Ver.2.0, please update your VS-880EX by following the procedure "To Update the VS-880EX" on p. 48.

If you use the VS-880, please update its software by following the procedure "Adding CD-R Capability to the VS-880" on p. 8.

**NOTE**

*You can use special SMFs (Standard MIDI Files) or an external Zip® drive to add the CD-R capability to your VS-Series recorder. You can download the required files from the Roland Website—[www.rolandus.com](http://www.rolandus.com)—or order them from Roland Customer Service at 323-890-3700 ext. 2289.*

**NOTE**

*The VS-CDRII package does not include the owner's manuals for the VS-1680 V-XPANDED or VS-880EX Ver.2.0. Please call your nearest Roland Service Center or authorized Roland distributor in your country, as shown at the end of this manual.*

## Features

### Create Your Own CDs

You can create original audio CDs that can be played on any ordinary CD player.

### You Can Listen to the Contents of CDs

You can use the VS-880 to listen to your CDs (CD Player feature). You can play your original CDs—as well as audio CDs you have purchased—in the VS-CDRII.

### You Can Save the Song Data

You can save the song data recorded in the internal hard disk of a Roland VS series recorder onto a CD-R disc or CD-RW disc.

## Checking Supplied Items

The following items come with the VS-CDRII package. Please take a moment to confirm that all of the items have been included.

- VS-CDRII (CD-RW drive)
- VS-CDRII *Owner's Manual* (this book)
- floppy disks containing system update Standard MIDI Files (SMFs) in PC and Macintosh format

---

## How to Read This Owner's Manual

The *VS-CDRII Owner's Manual* is organized as follows.



*This manual describes use of the VS-CDRII with a VS-880 using system software Ver. 3.20A or higher. If you use the VS-880, please refer to the VS-880 Owner's Manual for additional details on using the VS-880, as needed.*

*If you're using a VS-1680 V-XPANDED or VS-880EX Ver. 2.0 or higher, please refer to its Owner's Manual as necessary. Please refer also to "If You Are Using the VS-1680/VS-880EX" and "Appendices" in this manual.*



*The explanations in this manual include illustrations that depict what will typically be shown on your display. Note, however, that your unit may incorporate a newer, enhanced version of the system (e.g., includes newer sounds), so what you actually see in the display may not always match what appears in the manual.*

### 1. Adding CD-R Capability to the VS-880

This describes how to update the VS-880 using Standard MIDI Files (SMFs) or update files on a Zip disk to add CD-R capability. Please read this before turning on and operating the VS-CDRII.

### 2. Basic Operation (Preparing Songs)

This is a general overview explaining the process of preparing a song and recording and editing with the VS-880 up to the point of preparing the final CD. Please read both the *VS-880 Quick Start* and the *VS-880 Owner's Manual*.

### 3. Making Original CDs

This explains the procedure for taking the song data created in "Basic Operation (Preparing Songs)" and actually writing the CD, as well as listening to it to confirm its contents. Please read this as you go through the procedure.

### 4. Saving Song Data

This describes saving—backing up—the song data created in "Basic Operation (Preparing Songs)" to the CD-R disc, and recovering the data. Please read this as you go through the procedure.

### 5. If You Are Using the VS-1680/VS-880EX

This explains how to use the VS-CDRII in combination with the VS-1680 V-XPANDED and VS-880EX. Please read the respective *Owner's Manual* for further information.

### 6. Appendices

This section, with topics such as "Troubleshooting", "Q & A", "List of Terms" and others, explains basic performance and application operations. Please read the relevant topics as needed.

# Adding CD-R Capability to the VS-880

You can update the VS-880 for use with the VS-CDRII using the included Standard MIDI Files. If you have an external Zip drive, you can also update the VS-880's software using the Zip drive. Both types of update files can be downloaded from the Roland Website: [www.rolandus.com](http://www.rolandus.com).

You can also order the updater files directly from Roland Customer Service at 323-890-3700 ext. 2289. Ask for:

- PC-format SMF floppies—Part # SU-40 (System-A); Part # SU-41 (System-B)
- Macintosh-format SMF floppies—Part # SU-42 (System-A); Part # SU-43 (System-B)
- System update on Zip disk—Part # SU24Z (includes System-A and System-B)

## Before Adding the CD-R Capability

Note the following in regard to adding the CD-R capability to your VS-880.

### Required Items

- VS-880
- if updating the VS-880 using Standard MIDI Files (SMFs)
  - external MIDI sequencer that can load and play DOS or Macintosh Standard MIDI Files
  - MIDI cable
  - floppy disks containing system update SMF files
- if updating the VS-880 from an external Zip disk
  - external 100MB SCSI Zip drive and SCSI cable
  - Zip disk containing system updater

### About Disk Drives

After adding the CD-R capability, you can use your current disk drive or disk just as before. No reinitialization is necessary. However, as a precaution, it is recommended that you back up your song data before updating the system software.

### About Songs

After adding the CD-R capability, you can listen to the songs currently saved on your disk drive just as before.

### About Effects (With VS8F-1 Installed)

Effects patches saved as user patches, or effects patches recorded as scenes that were created before the new capability was added, can be used without modification after installation of the CD-R capability.

### Switching Between CD-R and DAT Use

Once your VS-880 has been updated, you'll be able to configure its system in either of two ways:  
SYSTEM-A: You can use VS-CDRII drive. But you cannot use DAT backup/verify/recover capability.  
SYSTEM-B: You cannot use VS-CDRII drive. But you can use DAT backup/verify/recover capability.

After you add the CD-R capability to the VS-880, SYSTEM-A is active. In this case, you can use the VS-CDRII drive, but you cannot use the DAT backup/verify/recover capability. For your song data backup, you can use the CD-R or CD-RW discs, not DAT.

If you already have your song data saved to DAT, first switch the system of the VS-880 to SYSTEM-B (p.11), and then recover the songs from DAT. Then switch the system back to SYSTEM-A and save them to the CD-R or CD-RW discs.

*Always use SYSTEM-A if you do not use the DAT backup/verify/recover capability regularly.*





## Procedure for Adding CD-R Capability Using SMFs

The VS-CDRII package includes floppy disks with eight Standard MIDI Files for updating the VS-880 with CD-R capability. You must load the SMFs into your sequencer and "play" them into the VS-880.

- 1** Connect the MIDI OUT port of the sequencer to the MIDI IN port of the VS-880.
- 2** Hold down the CH EDIT button 7 and STATUS button 7 while powering on the VS-880. The message "System Update?" will be displayed.
- 3** Press YES. The message "Waiting MIDI-EX" will be displayed.
- 4** Load the appropriately formatted Standard MIDI Files into your sequencer (PC or Macintosh).
- 5** Play all of the Standard MIDI Files: "VS-880-1.mid" through "VS-880-8.mid," in sequential order.
- 6** After all of the SMFs have been played into the VS-880, the message "Update SysPRG?" will be displayed. Press YES.
- 7** The message "Please Reboot OK" will be displayed. The system software of the VS-880 has now been updated.
- 8** Restart the VS-880 (power off and then on again). The new system version will be shown in the lower left corner of the display as the unit is booting up.

### NOTE

We have tested the SMF files with the following MIDI sequencing programs; Vision (Opcode), Performer (MOTU), Cubase (Steinberg/Jones), and Logic (Emagic). We were successful in updating the VS-880. Some sequencers do not send system exclusive messages that are embedded in a Standard MIDI File properly, and these programs will not work for updating the operating system of the VS-880. A demo version of Cubase is available on the Steinberg/Jones Website (<http://steinberg-na.com>). The demo version will work for this application. If you continue to have problems with the update procedure, check your MIDI/interface setup.

## Procedure for Adding CD-R Capability Using an External Zip Drive

The following steps describe how to update your VS-880 using a system update file on a Zip disk.

- 1** Check to make sure that the power to all connected equipment is turned off.
- 2** Unplug all cables (including audio, SCSI, and digital cables) connected to the VS-880.
- 3** Connect the VS-880 and your SCSI Zip drive with a SCSI cable. Do not connect any type of disk drive other than a Zip Drive (p. 50).

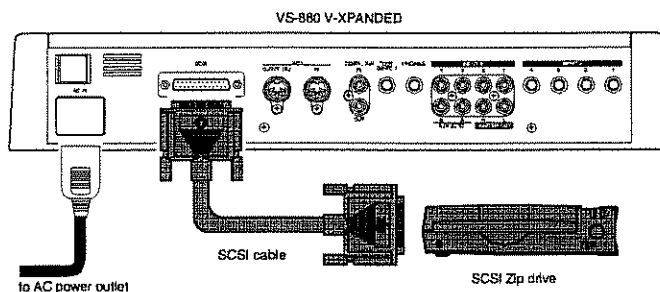

- 4 Turn on the power to the Zip drive.
- 5 Insert the Zip disk containing the system updater into the Zip drive.
- 6 Attach the power cord to the VS-880.
- 7 Turn on the power to the VS-880 with the power switch on the rear panel. "Update SysPRG?" (Update system program?) appears in the display.

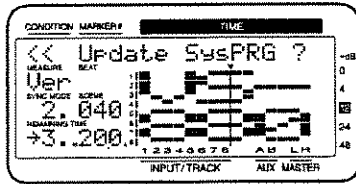

**If the above does not appear on the screen**  
The VS-880 is not recognizing the updater on the Zip disk. Turn off the power, reinsert the disk in the Zip drive properly, and turn on the power again.

- 8 Press the [YES] button. Installation takes about twenty seconds. A countdown displayed on the screen indicates the status of the installation as it progresses.

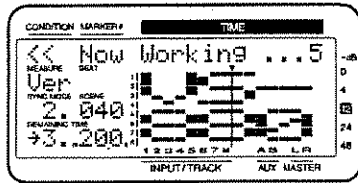

**NOTE**

*Be absolutely sure that the power is not turned off before the end of the installation. Loss or interruption of power before the process is complete may result in damage to the system.*

- 9 If installation is successful, "Please Reboot OK" appears in the display. Turn off the power to the VS-880 at this time.

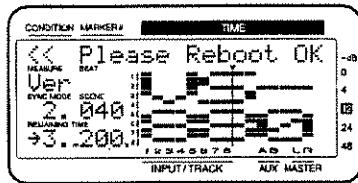

- 10 Turn on the power once again.

- 11** "Verify SysPRG?" appears in the display. Press the [YES] button. The VS-880 conducts an auto-diagnosis to determine if the installation was properly carried out. A countdown displayed on the screen indicates the status of the self-diagnosis as it progresses.

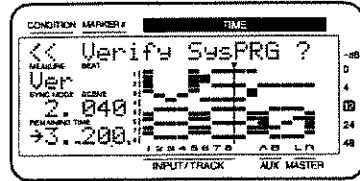

**NOTE**

*Be absolutely sure that the power is not turned off or cut before the end of the auto-diagnosis. Loss or interruption of power before the process is complete may result in damage to the system.*

- 12** Once the auto-diagnosis verifies that the installation was successful, the VS-880 restarts automatically. The version number of the system software appears in the "REMAINING TIME" window. Check to make sure that the version number is 3.20A or higher.

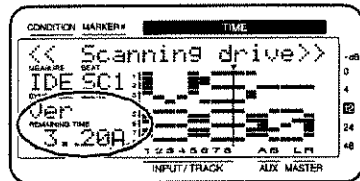

**If the above is not displayed on the screen**

Installation was not successful. Follow the instructions given in "Procedure for Adding CD-R Capability Using an External Zip Drive" once again.

With this, the CD-R capability has been successfully installed on the VS-880.

After shutting down, the Zip disk can be removed.

From now on, when starting up the VS-880, the Zip disk containing the system update is no longer necessary. Store this Zip disk in a cool, safe place. Additionally, the Zip disk **cannot be used on any device other than the VS-880**.

**NOTE**

*The VS-CDRII's digital connections are normally disabled during VS-880 operations. When this is the case, you cannot record the output of your CD player through the VS-880's DIGITAL IN connector. For details on recording digitally from the VS-CDRII, please read "To Record Digital Signals" (p. 19).*

## Switching the system (SYSTEM A ↔ SYSTEM B)

If you've updated the VS-880 using SMFs, you can switch the VS-880 to System-B by following the SMF system update procedure on p. 9, except that in Steps 4 and 5, you'll use the System-B SMFs instead of the System-A SMFs.

The following instructions describe how to switch the VS-880 system between SYSTEM-A and SYSTEM-B.

- 1** Check to make sure that the power to all connected equipment is turned off.
- 2** Unplug all cables (including audio, SCSI, and digital cables) connected to the VS-880.

- 3** Connect the VS-880 and your SCSI Zip drive with a SCSI cable. Do not connect any type of disk drive other than a Zip drive (p.50).
- 4** Turn on the power to the SCSI Zip drive.
- 5** Insert the Zip disk containing the system updater into the Zip drive.
- 6** Attach the power cord to the VS-880.
- 7** Turn on the power to the VS-880 with the power switch on the rear panel. The following message appears in the display.

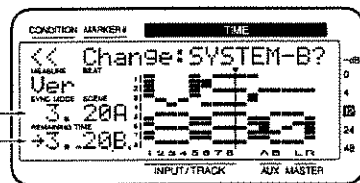

current system (Ver.3.20A in this example)  
system to be switched to (Ver.3.20B in this example)

- 8** Press the [YES] button. The Zip disk is ejected and system-switching starts, taking about fifteen seconds. A countdown displayed on the screen indicates the status of the procedure.

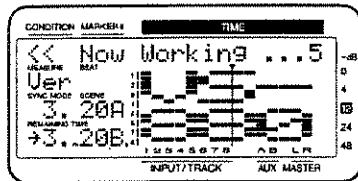

**NOTE**

*Be absolutely sure that the power is not turned off before the end of the switching. Loss or interruption of power before the process is complete may result in damage to the system.*

- 9** If switching is successful, "Please Reboot OK" appears in the display. Turn off the power to the VS-880 at this time.
- 10** Turn on the power once again. Check to make sure that the system switched correctly.

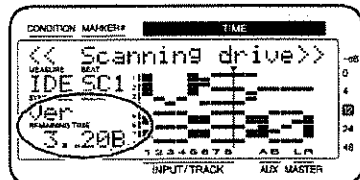

# Basic Operation (Preparing Songs)

This is a general overview explaining the process of preparing a song, recording and editing with the VS-880 up to the preparation of the CD itself. Please read both the *VS-880 Quick Start* and the *VS-880 (V-XPANDED) Owner's Manual*.

## Before You Begin Recording

Before making any songs with the VS-880, please observe the following notes.

### Items Necessary for Recording

- VS-880 (1)
- Internal IDE hard disk (1)
- Audio equipment for master out, stereo headphones
- Instruments or equipment for recording (electric guitar, synthesizer, CD player, etc.) or microphone

### Connecting the VS-880 to Audio Equipment

► *Quick Start* (p. 3)

**NOTE**

*To prevent malfunction and/or damage to speakers or other devices, always turn down the volume, and turn off the power on all devices before making any connections.*

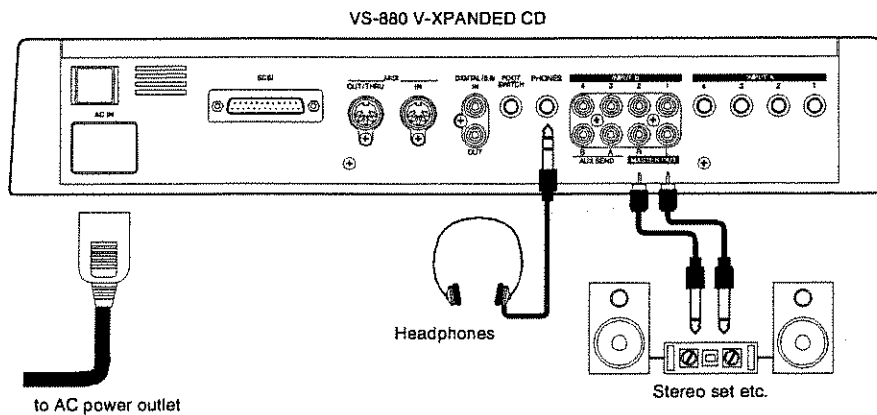

### Turning On the Power

► *Quick Start* (p. 4)

**NOTE**

*Once the connections have been completed, turn on power to your various devices in the order specified. If you turn on devices in the wrong order, you risk causing a malfunction and/or damage to speakers and other devices.*

*This unit is equipped with a protection circuit. A brief interval (a few seconds) after power up is required before the unit will operate normally.*

- 1** Turn on any SCSI device (Zip drive or other device) that is to be connected.
- 2** Turn on the power to the VS-880.
- 3** Turn on the audio equipment.
- 4** Adjust the volume of the audio equipment to an appropriate level.

---

## Creating New Songs (Song New)

► *Quick Start* (p. 9), *V-XPANDED Owner's Manual* (p. 62)

- 1** Press [SONG] until the message "SNG Song New?" appears in the display.
- 2** Press [YES].
- 3** "SNG SampleRate=" appears on the screen. Select "44k" (44.1 kHz). **Choosing any sample rate other than 44.1 kHz will prevent you from being able to make your own original CD.**
- 4** Press PARAMETER [▶▶].
- 5** "SNG RecordMode=" appears in the display. Select the recording mode you prefer.
- 6** Press [YES]. "SNG Create NewSong?" appears in the display.
- 7** Press [YES]. "SNG Create New-Sure?" appears in the display.
- 8** Press [YES]. "SNG STORE Current?" appears in the display.
- 9** If you want to store the currently selected song, press [YES]; if not, press [NO]. Once the new song is created, the VS-880 returns to Play mode.

## A General Overview of the Multitrack Recording Process

The VS-880's basic recording procedure is roughly the same as the process used in analog multitrack recording. Additionally, with the VS8F-1 Effect Expansion Board installed, you can record using the VS-880's internal/built-in effects.

- 1** Connect an instrument or microphone to the VS-880.
- 2** Set the song's tempo, and prepare the tempo map.
- 3** While listening to the metronome, record the drums, bass, and any other basic rhythm section parts.
- 4** While listening to the rhythm section being played back, record the other parts (electric guitar, synthesizer, vocals, etc.) of the song (overdubbing).
- 5** Only mistakes need to be re-recorded (punch in/out). Naturally, you can record over any material, including whole tracks, that you don't like.

## Connecting to Instruments

► *Quick Start* (p. 10), *V-XPANDED Owner's Manual* (p. 63)

- 1** Turn down the VS-880's master fader.
- 2** Connect an instrument or mic to the INPUT A or INPUT B jack.

## Sounding the Metronome

### Preparing Tempo Maps

► *V-XPANDED Owner's Manual* (p. 90)

- 1** Press [SYSTEM] until "SYS Sync/Tempo?" appears in the display.
- 2** Press [YES].
- 3** Press PARAMETER [▶▶] until "SYS Syn:Tmap 1=" appears in the display.
- 4** Pressing CURSOR [▶] moves the cursor. Set the tempo, opening measure, and beat for the song you intend to record.
- 5** Press [PLAY (DISPLAY)]. The VS-880 is returned to Play mode.

### Making Metronome Settings

► *V-XPANDED Owner's Manual* (p. 109)

- 1** Press [SYSTEM] until "SYS System PRM?" appears in the display.
- 2** Press [YES].
- 3** Press PARAMETER [▶▶] until "SYS MetroOut=" appears in the display.
- 4** Select "INT."
- 5** Press PARAMETER [▶▶] until "SYS MetroMd=" appears in the display.
- 6** Select "Rec&Play."
- 7** Press [PLAY (DISPLAY)]. The VS-880 is returned to Play mode.

## Recording Performances to Tracks

► *Quick Start* (p. 10), *V-XPANDED Owner's Manual* (p. 63)

- 1** For the mixer mode, select **INPUT → TRACK Mode**.
- 2** Press [CH EDIT] for the track you wish to record.
- 3** While pressing [SHIFT], press the [Input/BUSS (CH EDIT)] for Track 1.
- 4** Select the input source (INPUT 1–4) to be recorded. For example, if the instrument to be recorded is connected to INPUT 1, select "INPUT-1" as the input source.

- 5** Press [PLAY (DISPLAY)]. The VS-880 is returned to Play mode.
- 6** Adjust the input sensitivity with the INPUT SENS knob.
- 7** Set the Track Status indicator for the track you wish to record so it is flashing red in record-standby.
- 8** Press [REC].
- 9** Press [PLAY]. Recording begins. Begin playing in time with the metronome.
- 10** When you are finished recording, press [STOP].

### Recording with Reverb Effect Applied (Loop)

► *V-XPANDED Owner's Manual* (p. 103)

#### Setting the Input Mix (INPUT MIX)

- 1** For the mixer mode, select **INPUT MIX Mode**.
- 2** Press the input mixer [CH EDIT] to match the input source. For example, press Channel 1 if the input source is from INPUT 1; press Channels 5 and 6 if the input source is DIGITAL IN (5, 6).
- 3** While pressing [SHIFT], press the [Input/BUSS (CH EDIT)] for Channel 1.
- 4** Press PARAMETER [▶▶]. "BUSS Sel=" appears in the display.
- 5** Select the output bus for the tracks to be recorded. For example, select "1-2" for Tracks 1 and 2.
- 6** While pressing [SHIFT], press the [EFFECT-1 (CH EDIT)] for Channel 7. "EFFECT1" appears in the display.
- 7** Pressing PARAMETER [▶▶] changes the display. Adjust the Effect 1 send level and pan as needed.

#### Setting the Recording Mix (TRACK MIX)

- 8** While pressing [SELECT], switch the mixer mode to **TRACK MIX Mode**.
- 9** Press [CH EDIT] for the tracks you want to record.
- 10** While pressing [SHIFT], press the [Input/BUSS (CH EDIT)] for Channel 1.
- 11** Press PARAMETER [▶▶]. "BUSS Sel=" appears in the display.
- 12** Select "MIX" to be able to monitor the MASTER OUT.



## Setting Master Blocks

- 
- 13** Press [EDIT (SOLO)] until "MST EFF1 RTN to=" appears in the display.
- 
- 14** Select the output bus for the track to be recorded. For example, select "1-2" for Tracks 1 and 2.
- 
- 15** Pressing PARAMETER [▶▶] changes the display. Adjust the Effect 1 return level and Effect 1 return balance as needed.

## Setting Effects

- 
- 16** Press [EFFECT] until "EFF EFFECT-1 PRM?" appears in the display.
- 
- 17** Press [YES].
- 
- 18** Select Effect 1. Select something like "A00 RV:LargeHall" or a similar setting.
- 
- 19** Press [YES].

## Recording

- 
- 20** Press [PLAY (DISPLAY)]. The VS-880 is returned to Play mode.
- 
- 21** Record according to the instructions in "Recording Performances to Tracks" (p. 15).

**Recording with Amp Simulator Applied (Insert)**

▶ *V-XPANDED Owner's Manual* (p. 35)

- 
- 1** For the mixer mode, select **INPUT → TRACK Mode**.
- 
- 2** Press [CH EDIT] for the track you wish to record.
- 
- 3** While pressing [SHIFT], press the [Input/BUSS (CH EDIT)] for Track 1.
- 
- 4** Select the input source (INPUT 1–4) to be recorded. For example, if the instrument to be recorded is connected to INPUT 1, select "INPUT-1" as the input source.
- 
- 5** While pressing [SHIFT], press [EFFECT-1 (CH EDIT)] for Track 7.
- 
- 6** Select which way want to insert the effect. For example, when recording in stereo, insert with "Insert L" and "Insert R."
- 
- 7** Press PARAMETER [▶▶] until "EQ/Eff PreIns=" appears in the display.
- 
- 8** Select "On."

- 9** Press [EFFECT] until "EFF EFFECT-1 PRM?" appears in the display.
- 10** Press [YES].
- 11** Select the effect you want to use. Here, use something like "A52 GA: JazChorus."
- 12** Press [YES].
- 13** Press [PLAY (DISPLAY)]. The VS-880 is returned to Play mode.
- 14** Record according to the instructions in "Recording Performances to Tracks" (p. 15).

### Recording to Separate Tracks (Overdubbing)

►► *Quick Start* (p. 12), *V-XPANDED Owner's Manual* (p. 64)

- 1** For the mixer mode, select **INPUT → TRACK Mode**.
- 2** Press [CH EDIT] for the track you wish to record.
- 3** While pressing [SHIFT], press the [Input/BUSS (CH EDIT)]. "Input=" appears in the display.
- 4** Select the input source (INPUT 1–4) to be recorded. For example, if the instrument to be recorded is connected to INPUT 1, select "INPUT-1" as the input source.
- 5** Press [PLAY (DISPLAY)]. The VS-880 is returned to Play mode.
- 6** Set the track status indicator for the track you want to play back to a steady green light (playback mode).
- 7** Set the track status indicator for the track you want to record onto to a flashing red light (record standby mode).
- 8** Record according to the instructions in "Recording Performances to Tracks" (p. 15).

### Recording Over Mistakes Only (Punch-In/Out)

►► *Quick Start* (p. 16), *V-XPANDED Owner's Manual* (p. 64)

- 1** Set the track status indicator of the track you want to record over to a flashing red light (record standby mode).
- 2** Press [PLAY]. Playback begins.
- 3** Press [REC] when you reach the place you want to record over.
- 4** Press [REC] again when you are through recording.

## To Record Digital Signals

► V-XPANDED Owner's Manual (p. 72)

### Items Necessary for Digital Connections

- VS-880 V-XPANDED CD (1)
- CD player (see "To Digitally Connect CD Players" below), DAT recorder, MD player, or other digital audio device
- Digital connector cable (coaxial)
- Optical-coaxial converter (if necessary)

### Connecting to Digital Devices

Connect the VS-880's DIGITAL IN connector (coaxial) to the digital output of the digital audio device.



*If you want to connect digital devices that have only optic-type output connectors, you will need a commercially available converter. If you have any questions or would like more information, please contact the nearest Roland Service Center, or an authorized Roland distributor, as listed on the "Information" page.*

### Selecting Digital Input as Source

- 1 Press [SYSTEM] until "SYS System PRM?" appears in the display.
- 2 Press [YES].
- 3 Press PARAMETER [▶▶] until "SYS MasterClk=" appears in the display.
- 4 Select "DIGITL." "Digital In Lock" appears in the display.
- 5 Press [PLAY (DISPLAY)]. The VS-880 is returned to Play mode.

### Selecting the Input Source

- 1 Press [CH EDIT] for the track you wish to record.
- 2 While pressing [SHIFT], press the [Input/BUSS (CH EDIT)] for Channel 1.
- 3 Select "DIGITAL-L" or "DIGITAL-R."
- 4 Press [PLAY (DISPLAY)]. The VS-880 is returned to Play mode.

### To Digitally Connect CD Players

The VS-CDRII's digital connectors are disabled during normal operations with the VS-880—when this is the case, you cannot record the output of your CD player via the DIGITAL IN connector. If you want to connect a CD player to the digital connector, carry out the following procedure.

- 1 Press [SYSTEM] until "System PRM?" appears in the display.
- 2 Press [YES].

- 3** Press PARAMETER [▶▶] until "CD DigiREC→ On?" appears in the display.
- 4** Press [YES]. "Obey Copyrights?" appears in the display.
- 5** Read the License Agreement (p. 54) thoroughly. If you agree to the terms, Press [YES]. After the screen shows "— Complete —", the VS-880 is returned to Play mode. Afterwards, you can connect to a CD player and a digital connector. If you don't agree to the terms, press [NO]; the VS-880 automatically returns to Play mode.
- 6** This enables the VS-CDRII's digital connectors—proceed to "Selecting Digital Input as Source" on p. 19.

#### To Cancel a Digital Connection with a CD Player

When you want to cancel a connection with a CD player, carry out the following procedure.

- 1** Press [SYSTEM] until "System PRM?" appears in the display.
- 2** Press [YES].
- 3** Press PARAMETER [▶▶] until "CD DigiREC→ Off?" appears in the display.
- 4** Press [YES]. After the screen shows "— Complete —", the VS-880 is returned to Play mode. Afterwards, digital connections with a CD player will not work.

## Creating Master Data (Mix Down)

What is written to the CD-R disc is the stereo performance data of the current song recorded onto two tracks. This is something different than the performance data output from the MASTER OUT or PHONES jack, as described below.

- **Track Bouncing**

Two designated tracks—L (Left) and R (Right)—are written to the CD-R disc. After recording and overdubbing is complete, use track bouncing to mix down the song's finished performance data onto two tracks (p. 22).

- **Mixing**

Mixer adjustments made during playback are not registered or stored on the CD-R disc. For example, if you use the master fader to control fade ins and fade outs, these changes will not be accurately captured in the data written to the CD-R, with the result being more like sounds that are cutting in and out. Thus, it is preferable to bounce tracks while making adjustments to fader levels, equalizer levels, pan controls, and other realtime settings beforehand.

Setting Auto Mix beforehand makes Track Bouncing much easier.

- **Effects**

Effects applied during playback are not recorded to the CD-R disc. For example, reverb or delay applied to the output of each track will not be written to the CD-R, so the result will sound as if no effect was applied at all. Therefore, it is better to bounce tracks while adding effects beforehand (p. 22).

- **V-Tracks**

You cannot select different V-Tracks during the recording of the L and R tracks to the CD-R disc. Any V-Track switching you require must be performed during the bounce that creates the L and R tracks.

## Balancing the Tracks (Auto Mix)

► *V-XPANDED Owner's Manual* (p. 17)

Pre-recording fade ins and fade outs, effect send levels, and so on with Auto Mix can save you a lot of work when the time comes to work the faders in bouncing tracks.

## Adjusting the Tone (Equalizer)

► *Quick Start* (p. 17), *V-XPANDED Owner's Manual* (p. 67)

- 1 Press [CH EDIT] for the track on which you want to equalize the tone.
- 2 While pressing [SHIFT], press the [EQ Low (CH EDIT)] for Channel 3.
- 3 Pressing CURSOR [▶] or PARAMETER [▶▶] changes the screen. Adjust the equalizer center frequency, gain, and bandwidth as needed.



*After you have finished the equalization for each of the tracks, we suggest that you register the mixer settings as a scene.*

► *V-XPANDED Owner's Manual* (p. 51)

- 4 Press [SCENE]
- 5 Press [LOC] for the number you want to register. For example, if you want to register to Scene 1, Press [LOC1/5].

## Adjusting Placement of the Sound (Level/Pan)

► *V-XPANDED Owner's Manual* (p.18 )

- 1 While pressing [SCENE], press [SELECT]. The [SELECT] indicator flashes.
- 2 Move to the location in the song where you want to use Auto Mix.
- 3 While pressing [SCENE], press [REC].
- 4 Adjust the faders and pan controls for the tracks in the Auto Mix.
- 5 Press [PLAY].
- 6 While listening to the material on the tracks, adjust each of the faders and pan controls on the top panel.
- 7 When you are finished mixing, press [STOP].

## Arranging Multiple Tracks in Stereo (Track Bouncing)

► *V-XPANDED Owner's Manual* (p. 67)

The master tracks—the tracks that are used as the material that actually gets written to the CD-R disc—can be specified at the time of writing the CD-R. Ordinarily, the performance data on the tracks is written as shown below, so we recommend you leave these tracks open for use as master tracks.

Recording Mode	L Track	R Track
MAS	5	6
MT1	7	8
MT2	7	8
LIV	7	8

## Bouncing Tracks with Reverb Applied (Loop)

► *V-XPANDED Owner's Manual* (p. 106)

### Setting Playback Tracks

- 1** For the mixer mode, select **INPUT** → **TRACK Mode**.
- 2** Press **[CH EDIT]** for the tracks you want to play back.
- 3** When you press **PARAMETER** [**◀◀**] [**▶▶**], "Mix Sw=" appears in the display.
- 4** Select how the signal is to be sent to the MIX bus. For example, if you are going to use faders to adjust the volume, then "PstFade" should be set.
- 5** While pressing **[SHIFT]**, press the **[EFFECT-1 (CH EDIT)]** for Channel 7. "EFFECT1" appears in the display.
- 6** Select how the signal is to be sent to the MIX bus. For example, if you are going to use channel faders to adjust the amount of effect being sent, then "PstFade" should be set.
- 7** Pressing **PARAMETER** [**▶▶**] changes the display. Adjust the Effect 1 send level and Effect 1 pan as needed.
- 8** Repeat Steps 1–7 for all tracks that are to be bounced.

### Setting the Recording Tracks

- 9** Press **[CH EDIT]** for the tracks you want to record. We recommend that in MAS recording mode you designate Tracks 5 and 6 as the tracks to record to, and in MT1, MT2, and LIVE recording modes Tracks 7 and 8.
- 10** While pressing **[SHIFT]**, press the **[Input/BUSS (CH EDIT)]** for Channel 1. "Input=" appears in the display.
- 11** Select the input source. For example, select "MIX-L" and "MIX-R" when recording the signal from the MIX bus.

---

**Setting Master Block**

- 
- 12** Press [EDIT (SOLO)] until "MST EFF1 RTN to=" appears in the display.
- 
- 13** Select the destination for the effects return. For example, select "MIX" if the effect is to be returned to the MIX bus.
- 
- 14** Pressing PARAMETER [▶▶] changes the display. Adjust the Effect 1 return level and Effect 1 balance as needed.

**Setting Effects**

- 
- 15** Press [EFFECT] until "EFF EFFECT-1 PRM?" appears in the display.
- 
- 16** Press [YES].
- 
- 17** Select Effect 1. Select something like "A00 RV:LargeHall" or a similar setting.
- 
- 18** Press [YES].

**Recording**

- 
- 19** Press [PLAY (DISPLAY)]. The VS-880 is returned to Play mode.
- 
- 20** Set the track status indicator for the track you want to play back to a steady green light (playback mode).
- 
- 21** Set the track status indicator for the track you want to record to a flashing red light (record-standby mode).
- 
- 22** Record according to the instructions in "Recording Performances to Tracks" (p. 15).

### Bouncing Tracks with Compression Applied (Insert)

This section explains the insertion of effects onto mixed recorded tracks and the settings for recording those sounds onto separate tracks. After recording a song, the whole song is compressed, which is effective for viewing the overall volume when bouncing tracks.

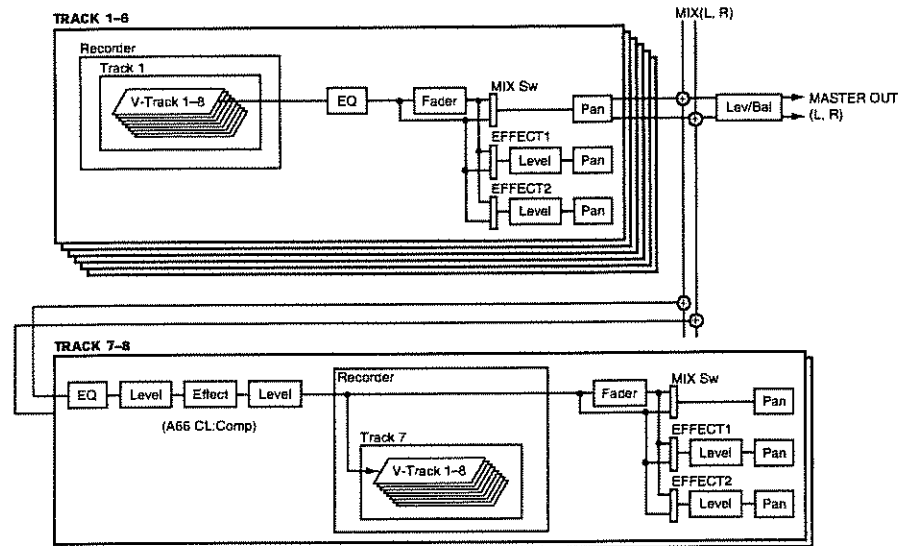

#### Setting Playback Tracks

- 1** For the mixer mode, select **INPUT → TRACK Mode**.
- 2** Press **[CH EDIT]** for the tracks you want to play back.
- 3** When you press **PARAMETER [◀◀] [▶▶]**, "Mix Sw=" appears in the display.
- 4** Select how the signal is to be sent to the MIX bus. For example, if you are going to use faders to adjust the volume, then "PstFade" should be set.
- 5** Repeat Steps 1–4 for all tracks that are to be bounced.

#### Setting the Recording Tracks

- 6** Press **[CH EDIT]** for the track you want to record to as the L Track. We recommend that in MAS recording mode you designate Track 5, and in MT1, MT2, and LIVE recording modes Track 7.
- 7** While pressing **[SHIFT]**, press the **[Input/BUSS (CH EDIT)]** for Channel 1. "Input=" appears in the display.
- 8** Select the input source. For example, select "MIX-L" when recording the signal from the MIX bus.
- 9** While pressing **[SHIFT]**, press the **[EFFECT-1 (CH EDIT)]** for Channel 7.
- 10** Insert the effect into the L channel of the MIX bus. Select "InsertL."



- 
- 11** Press PARAMETER [▶▶] until "EQ/EffPreIns=" appears in the display.
- 
- 12** Insert the effect and enable recording. Select "On."
- 
- 13** Repeat Steps 6–12 for the track you want to record on as the R Track. However, in Step 8 select "MIX-R" and in Step 10 "InsertR."

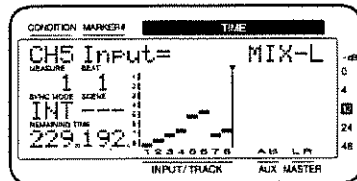

### Setting Effects

- 
- 14** Press [EFFECT] until "EFF EFFECT-1 PRM?" appears in the display.
- 
- 15** Press [YES].
- 
- 16** Select Effect 1. Select something like "A66 CL:Comp" or a similar setting.
- 
- 17** Press [YES].

### Recording

- 
- 18** Press [PLAY (DISPLAY)]. The VS-880 is returned to Play mode.
- 
- 19** Set the track status indicator for the track you want to play back to a steady green light (playback mode).
- 
- 20** Set the track status indicator for the track you want to record to a flashing red light (record standby mode).
- 
- 21** Record according to the instructions in "Recording Performances to Tracks" (p. 15).

## Deleting Unneeded Material (Track Cut)

► *V-XPANDED Owner's Manual* (p. 83)

When you've finished bouncing song data, the master tracks are written to the CD-R disc from the start point of "00h00m00s00" to the end of the song (song end).

Thus, any silent portions before or after the performance wastes part of the CD-R disc. To avoid this, delete the unnecessary portions.

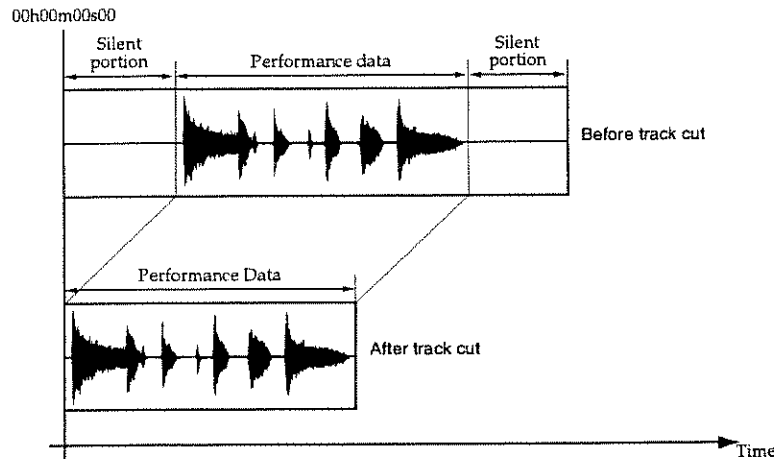

## Selecting the Portions to Be Written to the CD-R Disc

In order to simplify the Track Cut procedure, the range of desired material is selected and registered using easy-to-understand location points.

- 1** Move to the location in the song at which you want writing to begin.
- 2** Press [LOC 1/5]. The time is registered as Locate Point 1.
- 3** Move to the location in the song where you want writing to stop.
- 4** Press [LOC 2/6]. The time is registered as Locate Point 2.

## Deleting Unneeded Material After the Performance

- 1** Press [TRACK] until "Track Cut?" appears in the display.
- 2** Press [YES].
- 3** Press [SEL (CH EDIT)] for the track (L) to be written to the CD-R.
- 4** Select the V-Track (L) to be written to the CD-R.
- 5** Press [SEL (CH EDIT)] for the track (R) to be written to the CD-R.

- 6** Select the V-Track (R) to be written to the CD-R.
- 7** Press PARAMETER [▶▶]. "TRK St=" appears in the display.
- 8** Press [LOC 2/6].
- 9** Press PARAMETER [▶▶]. "TRK End=" appears in the display.
- 10** While pressing [SHIFT], press [SONG END (FF)].
- 11** Press PARAMETER [▶▶]. "Track Cut OK?" appears in the display.
- 12** Press [YES]. When Track Cut is completed, the VS-880 is returned to Play mode.

#### Deleting the Unneeded Material Before the Performance

- 1** Press [TRACK] until "Track Cut?" appears in the display.
- 2** Press [YES].
- 3** Press [SEL (CH EDIT)] for the track (L) to be written to the CD-R.
- 4** Select the V-Track (L) to be written to the CD-R.
- 5** Press [SEL (CH EDIT)] for the track (R) to be written to the CD-R.
- 6** Select the V-Track (R) to be written to the CD-R.
- 7** Press PARAMETER [▶▶]. "TRK St=" appears in the display.
- 8** Press [ZERO].
- 9** Press PARAMETER [▶▶]. "TRK End=" appears in the display.
- 10** Press [LOC 1/5].
- 11** Press PARAMETER [▶▶]. "Track Cut OK?" appears in the display.
- 12** Press [YES]. When Track Cut is completed, the VS-880 is returned to Play mode.



*Performance data that is written to the CD-R is not saved on the hard disk—it is merely performance data that is currently recorded onto tracks. You can carry out the song store procedure to save the data on your hard disk.*

▶▶ V-XPANDED Owner's Manual (p. 74)

# Making Original CDs

This section explains the procedures for taking the song data created in "Basic Operation (Preparing Songs)," actually writing the data to the CD, and listening to it to confirm the contents (auditioning).

## Before Making an Original CD

Before recording a song onto an audio CD with the VS-880, the following points should be noted.

### Items Necessary for Preparing Original CDs

- VS-880 (1)
- CD-RW drive (1)
- Internal IDE hard disk
- Blank CD-R (Compact Disc-Recordable)
- Audio equipment for MASTER OUT or headphones

### Connecting the CD-RW Drive

▶ V-XPANDED Owner's Manual (p. 130)

**NOTE**

To prevent malfunction and/or damage to speakers or other devices, always turn down the volume, and turn off the power on all devices before making any connections.

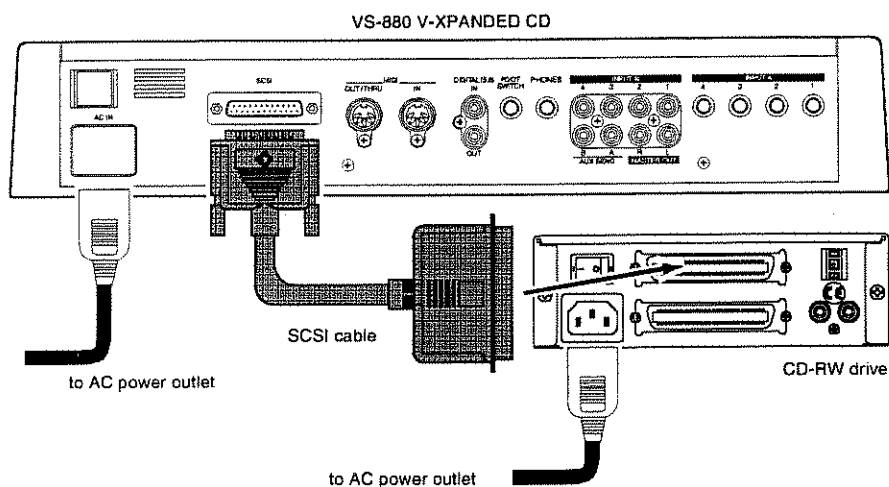

- 1** Turn on the power to the CD-RW drive.
- 2** Turn on the power to the VS-880.
- 3** Turn on the audio equipment.
- 4** Adjust the volume of the audio equipment to an appropriate level.

## Making an Original CD (CD-R Write)

The performance data on the VS-880's two selected tracks (stereo tracks) are written to the CD-R.

### Writing Songs to CD-R Discs

In carrying out the CD-R writing function, the VS-880 first prepares on the internal IDE hard disk an image data file that can be handled by the CD-R; that image data file is then written to the CD-R. Thus, there must be sufficient free space on the internal IDE hard disk to process the image data file.



*Any free space on the internal IDE hard disk, regardless of partitioning, may be used by the image data file. After the image data file has been written to the CD-R, however, the file is deleted automatically.*



*You can also write the audio data to a CD-RW disc. However, you cannot play a CD-RW disc on a conventional CD player, even if the disc is finalized. In such cases, you can listen to the data using the VS-880's CD Player function (p. 35). You can also rewrite the audio data on the CD-RW disc, so it's a good idea to write your data to a CD-RW disc and audition it before you write it to a CD-R disc.*



*If you use CD-RW discs, it is impossible to write the audio data to a finalized CD-RW disc or a CD-R disc which has been used for CD-R backup. You must first empty the disc using the procedure "Deleting the contents of CD-RW disc" (p. 42).*

### Arranging and Writing Multiple Songs to Disc

By sequencing a number of songs on one stereo pair of tracks, you can arrange those songs and write them to a CD-R disc. In this case, you can pre-set mark points at the song boundaries to function as track numbers, allowing you to write track numbers just like those used in ordinary audio CDs when using the CD-R drive to write an audio CD. If you wish to do this, use the following procedure.

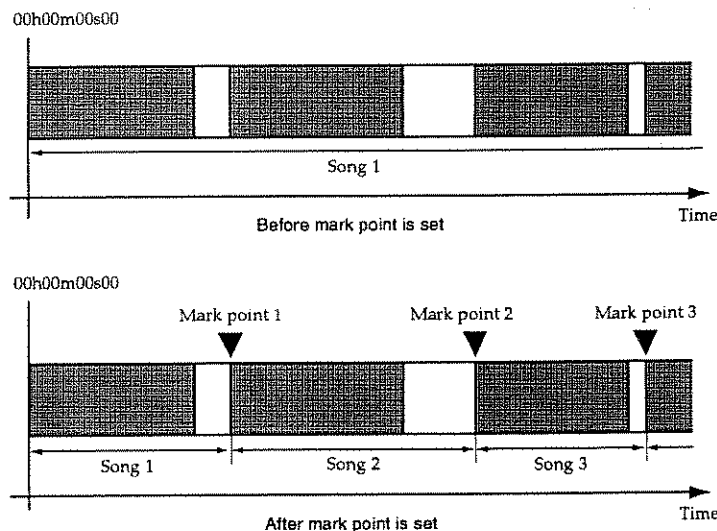

## Determining Song Boundaries (Track Number)

- 1 While listening to the song, move the track number to the location in the song you want. If called for, we recommend the use of the preview and scrub functions.  
 ➔ *V-XPANDED Owner's Manual* (p. 76)
- 2 While pressing [SONG], press [TAP]. Set a track number mark point at the present location on the track.

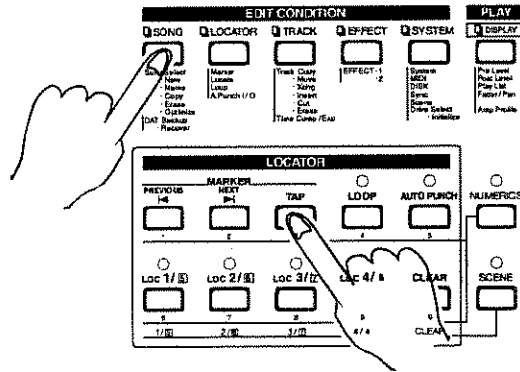

A "+" (plus sign) appears at the end of the track number mark point.

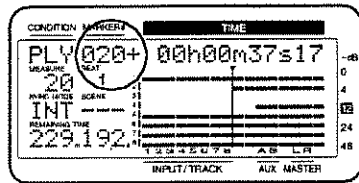

**NOTE**

You cannot set mark points for four seconds from the top of songs ("00h00m00s00").

**NOTE**

Due to audio CD standards, songs must be at least four seconds long. Thus, if you try to set two mark points as track numbers within four seconds of each other, "Can't Set Marker" appears in the display, and the process cannot be carried out. Reset the track number mark points so there is an interval greater than four seconds between them.

**MEMO**

Audio CD standards allow up to 99 songs to be stored on one disc. The VS-880 always sets a track number mark point at "00h00m00s00." Therefore, you can set an additional 98 mark points as track numbers.

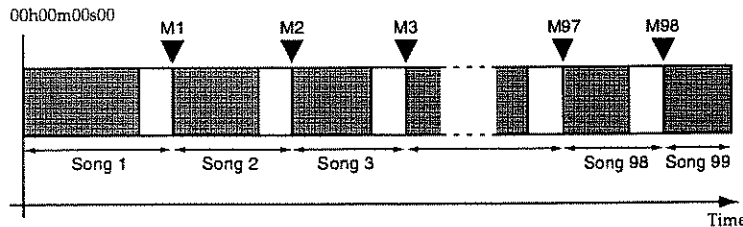

- 3** Pressing [PREVIOUS] while also pressing [SONG] moves you to the previous track number mark point. Pressing [NEXT] while also pressing [SONG] moves you to the next track number mark point. Please check the time at the track number.

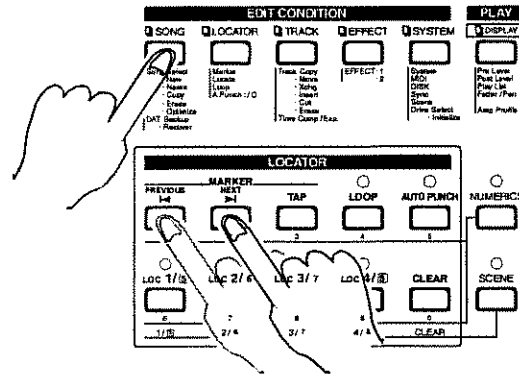

### Creating silence between songs (Disc at Once and Track at Once)

When writing songs to a CD-R disc, you can select how the space between songs will be handled.

#### Disc at Once

The song data and the track number markers attached to the song data will be written to the CD-R disc without change. However, additional song data cannot be added later to a CD-R disc that was written using Disc At Once. (It will be in the same condition as if Finalize had been performed.)

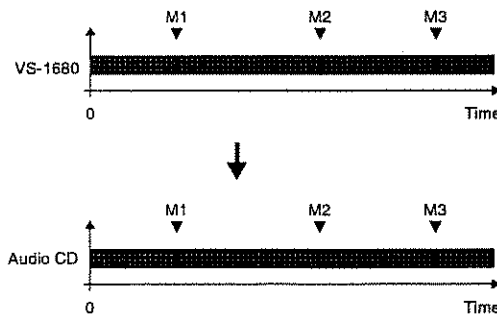

#### Track at Once

Two seconds of silence will automatically be written to the CD-R disc before each track number marker attached to the song data. (This is the same condition as when additional songs are written to the disc later.) Additional song data can be written to a CD-R disc that was written using Track at Once.

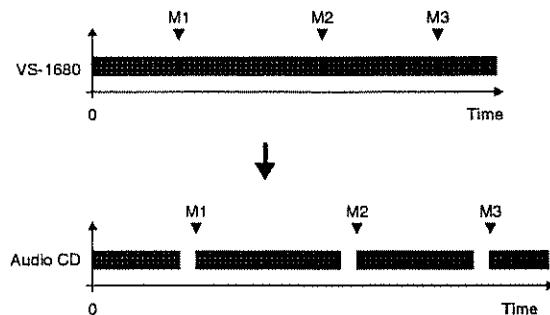



For example, if you have assigned track numbers to a medley of songs, *Disc At Once* would be the appropriate choice. This is because *Track At Once* would add approximately two seconds of silence between track numbers, causing the playback to sound fragmented.



If you use the CD-RW disc, you cannot choose "Track at Once" for writing data.

### Song writing procedure

- 1** Place a blank CD-R disc in the CD-RV-RW drive.
- 2** Press [SONG] several times until "SNG CD-R Write ?" appears in the display.
- 3** "STORE Current?" appears in the display. Press [YES] or [NO]. The VS-880EX displays the device ID number of the connected CD-RV-RW drive for a set time.

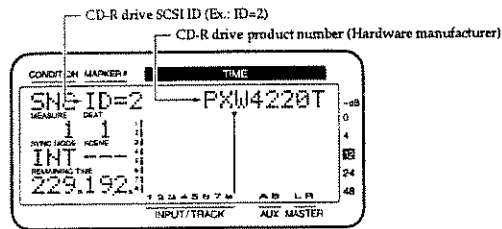

- 4** "Disc at Once?" or "Track at Once?" appears in the display. Press PARAMETER [◀◀] or [▶▶] to select how the data will be written, and press [YES].

#### Track at Once

Approximately two seconds of silence will be created between each song. Additional songs can be written later until the disc's capacity is exhausted.

#### Disc at Once

Silence will not be created between songs. However, no further data can be written on that disc.

- 4-1** If you select "Track at Once," press PARAMETER [◀◀] or [▶▶] to select whether or not the finalize is carried out, press [YES].



A TOC (Table Of Contents) will be written so that the audio CD created by the VS-880 can be played back on a standard CD player. It is not possible to write additional data to an audio CD that has been finalized.

#### Write w/o Fin. ?:

*Write only the song, and do not finalize.*

#### Write + Finalize:

*Write the song, and then finalize.*

#### Finalize:

*Finalize without writing the song. Select this if you have inserted a CD-R disc to which you have already written songs, but which has not yet been finalized.*



- 5 Press [SEL (CH EDIT)] for the track to be written to the CD-R L track.
- 6 Press CURSOR [▶▶].
- 7 Press [SEL (CH EDIT)] for the track to be written to the CD-R R track.
- 8 Press PARAMETER [▶▶]. "CD Speed" appears in the display. Use TIME/VALUE dial to select the speed at which the song will be written to the CD-R disc.

SNG CD Speed x 1

**CD Speed**

x2: The song will be written at double-speed.

x1: The song will be written at normal speed. This will provide higher reliability.



*With some CD-R discs, the data may not be written correctly if you select "x2." In this case, select "x1." However, if a CD-RW disc is inserted into the CD-RW drive, it will not be possible to select "x1" (the song will automatically be written at double speed).*



*Audio data written to a CD-RW disc cannot be played back on a conventional CD player. In such cases, you can listen to the data using the VS-880's CD Player function.*

- 9 The display appears as shown below. Check the capacity for each item.

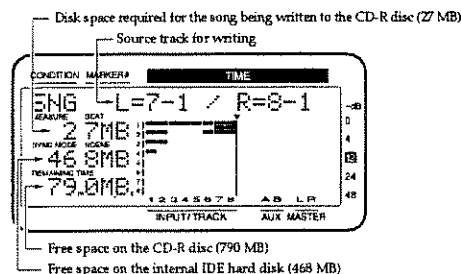

MEASURE, BEAT window: Disk space required for the song being written to the CD-R disc.

SYNC MODE, SCENE window: Free space on the internal IDE hard disk.

REMAINING TIME window: Free space on the CD-R disc.



*If "the space required for the song being written to the CD-R disc" exceeds the total of the "free space on the internal IDE hard disk" and the "free space on the CD-R disc," you cannot write the song to the CD-R disc.*



*The "space required for the song being written to the CD-R disc" is not necessarily the same as that for the song (the space is indicated when [SHIFT] + [SONG] are pressed). This is because of the number of tracks used and differences in recording mode.*

(▶▶ V-XPANDED Owner's Manual (p. 116)

- 10** Press PARAMETER [▶▶]. "SNG CD-R Write Sure?" appears in the display.
- 11** Press [YES]. "SNG CD Track No. OK?" is displayed.
- 12** Press [YES]. "Obey Copyrights?" is displayed.
- 13** Carefully read the License Agreement (p. 54); if you agree to the terms, press [YES.] Writing to the CD-R disc begins. If you do not agree to the terms, press [NO]—the VS-880 returns to its state at Step 2.

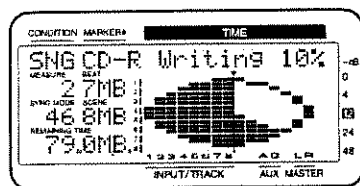
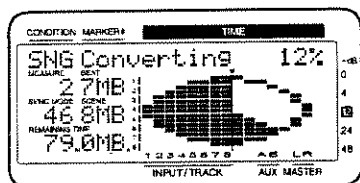

**If "Not 44.1k song!" appears**

The sample rate is not set to 44.1 kHz, so the song cannot be written to the CD-R disc. Press [YES] and [NO] to return to the state you were in at Step 1. Please read "Creating New Songs (Song New)" (p. 14).

**If "CD-R Not Ready!" appears**

Either the CD-R drive loading tray is still open, there is no CD-R disc loaded, or the CD-R drive is otherwise not ready. Pressing [YES] or [NO] will return the VS-880 to the condition at Step 1. Check the CD-R drive and carry out the procedure from Step 1 once more.

- 14** After the write procedure has been carried out normally, "Write Another?" appears in the display. When you want to write the same song information to another CD-R disc, insert another disc in the CD-R drive and press [YES]. Repeat Steps 10–14. Press [NO] to return to Step 2.

## Listening to the Songs You Have Written (CD Player Mode)

A newly completed CD-R disc that has not yet been finalized cannot be played on ordinary CD players. To listen to the songs that have been written on the disc—in order to check them—perform the steps below.



*Ordinary music CDs can also be played using the CD player mode.*



*You can listen to the contents of the disc through the VS-880's MASTER jack or the PHONES jack. You cannot output the contents through the CD-RW drive's PHONES jack or AUDIO out jack.*

- 1 Insert the CD-R disc (or ordinary music CD) into the CD-RW drive.
- 2 Press [SONG] until "SNG CD Player?" appears in the display.
- 3 Press [YES].
- 4 "STORE Current?" appears in the display. If you want to store the current song press [YES]; if not, press [NO]. "Scanning CD-R ." appears in the display. The VS-880 scans for the SCSI ID of the connected CD-RW drive. When it finds it, the ID number is displayed for a few moments. The CD-R disc information is then displayed.

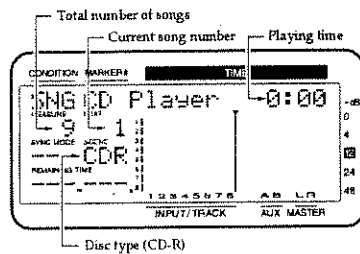

### If "No Disc" appears

There is no disc in the CD-RW drive. Press [YES] or [NO] to return to Step 1. Insert a commercial software CD or a CD-R disc on which recording has been completed, and try the operation once more.

### If "Blank Disc" appears

You are attempting to use the CD player feature with a CD-R disc that has no performance data written to it. Pressing [YES] or [NO] returns the VS-880 to the state you were in at Step 1. Insert a commercial software CD or a CD-R disc on which recording has been completed, and try the operation again.

## 5

Only the following buttons, knobs, and faders affect the sound. Try listening to the contents of the disc.

[ZERO]:	Goes to the start of the first song.
[REW]:	Rapidly rewinds as long as the button is held down.
[FF]:	Rapidly advances as long as the button is held down.
[STOP]:	Stops the CD.
[PLAY]:	Begins playing back from the present location.
[PREVIOUS]:	Returns to the previous song.
[NEXT]:	Advances to the next song.
Master Fader:	Adjusts overall volume.
Phones Knob:	Adjusts headphone volume.

**NOTE**

*Button, knob, and fader response may be slower than you expect, but this does not indicate any malfunction. For example, expect to wait about five seconds after pressing [PLAY] or [NEXT] before you hear sound.*

**NOTE**

*Transport control buttons are used for controlling the CD drive. They are not controls for the VS-880's songs. Furthermore, the content of the CD currently listened to cannot be recorded by the VS-880.*

## 6

When you are finished listening to the material, press [STOP].

## 7

Press [CANCEL]. This returns you to the status at Step 2. Pressing [SONG] also returns you to Step 2.

**NOTE**

*When listening to discs that have not been finalized, the last approximately 0.5 seconds of the song cannot be played back. Finalizing makes this portion audible.*

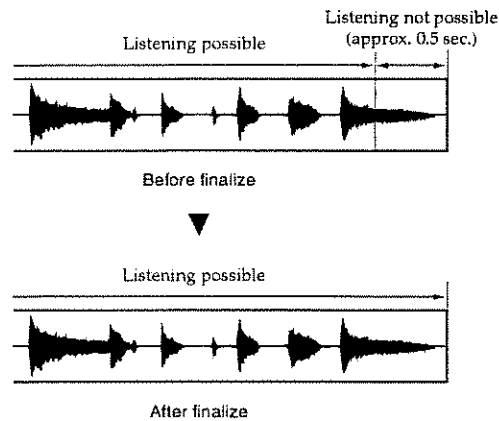

## Writing Additional Songs to the Disc

To the extent that any remaining free space allows, you can add songs to CD-R discs that have not yet been finalized. Repeat the procedure described in "Writing Songs to CD-R Discs" (p. 29).

Here you can insert approximately two seconds of blank space between the new song and the song before it. Additionally, the track number is recorded automatically.

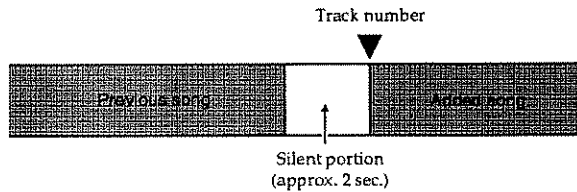

### To Delete Track Number Mark Points

Delete mark points used as track numbers the same way you would regular mark points.

- 1 Move to the mark point you want to delete.
- 2 While pressing [CLEAR], press [TAP].

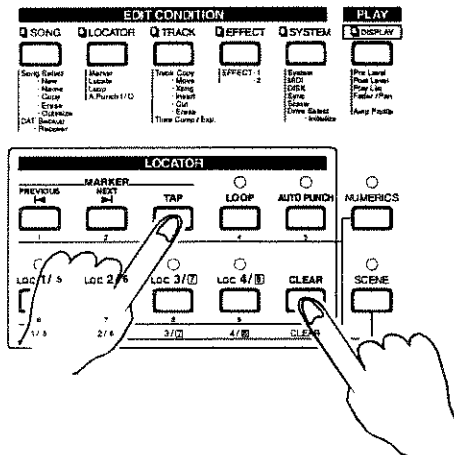

# Saving a song to a CD-RW disc

You can save song data stored on the VS-880 V-XPANDED CD hard disk to CD-R or CD-RW discs. This procedure is called "backing up." Conversely, the process of loading backed-up song data onto the internal hard disk is referred to as "recovering." Besides all V-track performance data, backed-up data also includes Locator, Marker, and Scene settings made in the songs.

In CD-R Backup, the song data is converted into a data format specifically for saving. This means that it will not be possible to directly play back the song data. If you wish to play back song data copied in archive format, you will need to reload the backed-up data into the current drive using the appropriate procedure. Furthermore, if you attempt to back up a song that does not fit on a single disc, it is copied onto multiple discs according to the free space available on the discs.

Song data backed up on CD-RW discs cannot be rewritten. Thus, this procedure is most appropriate for backing up completed song data in its final form.

- Song data recorded onto Zip disks cannot be backed up onto CD-RW discs.
- Song data cannot be backed up onto discs that already have songs recorded on them.
- Incorrectly conducting the backup procedure may result in the loss of data. Roland Corporation assumes no liability concerning such loss of data. Furthermore, Roland does not warrant any copied data, regardless of the performance or condition of the CD-RW drive.

## Items Necessary for CD-R Backup

- VS-880
- VS-CDRII (CD-RW drive)
- Internal IDE hard disk
- Blank CD-R or CD-RW disc

## Saving Songs to CD-RW Discs (CD-R Backup)

### Checking whether the song was saved correctly (+Verify)

After backing up a song to a CD-RW disc, you can check whether or not the data was saved correctly (i.e., check the recorded state of the data).

If, as a result of the +Verify operation, you are warned that the song data has not been saved correctly, you should back up again, to a different disc.



*When backing up to a CD-RW, we recommend that you use +Verify to check whether the backup was performed correctly. However, +Verify checks the entire surface of the disc, so it takes a considerable amount of time.*

### Specifying the speed of saving (Speed)

When backing up a song on a CD-RW disc, you can now specify the speed at which the data will be written.

### Backup procedure

- 1** As the current drive, select the drive (internal IDE hard disk) that contains the song you wish to back up.
- 2** Insert a CD-RW disc into the CD-RW drive.
- 3** Press [SONG] several times until "CD-R Backup ?" appears in the display.
- 4** Press [YES]. "STORE Current?" (Store the current song?) appears in the display.
- 5** If you wish to save the current song, press [YES]; if not, then press [NO]. If you have selected a demo song, then press [NO].
- 6** "CDR Bak=" appears in the display. Use the TIME/VALUE dial to select the song (only one song or all songs on the current drive) that you wish to save, and press PARAMETER [▶▶]. To back up all songs from the current drive, select "All".

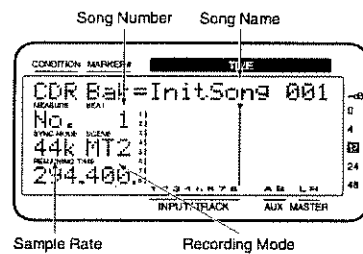

Total number of songs in the current drive (3 songs)

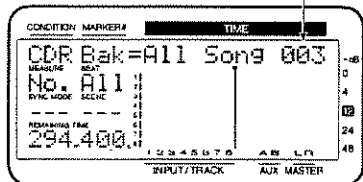

**7**

" +Verify=" Rotate the TIME/VALUE dial, and then press PARAMETER [▶▶].

SNG +Verify= On

+Verify

If this is turned "On", verification will be performed after the song data has been backed up, to check whether or not the data was saved correctly.

---

**8**

"CD Speed=" appears in the display. Rotate the TIME/VALUE dial.

SNG CD Speed x 1

CD Speed

You can select the speed at which the song data will be backed up to the CD-RW disc:

x2: Backup at double speed.

x1: Backup at normal speed. This will increase the reliability.

**NOTE**

*Depending on the disc, it may not be possible to back up reliably to a CD-R disc with a setting of "x2". In such cases, select "x1". Also, if you insert a CD-RW disc into a CD-RW drive, it will not be possible to select "x1" (backup will occur at double speed).*

---

**9**

Press [YES].

**If a CD-RW Disc that already contains data is used**

**9-1.** If a CD-RW disc that contains data is used in the above Step 2, "Finalized CD!" or "Not Blank CD!" appears in the display.

**9-2.** Press [Enter] and "CD-RW Erase?" appears.

**9-3.** Press [YES]. "CD-RW Erasing..." appears in the display and all the contents of the CD-RW disc are erased. If you do not wish to erase the data, press [NO], and then insert another CD-RW disc and press [YES].

**9-4.** When erase is finished, "Continue?" appears in the display. Press [YES]. If you do not wish to save the song data but only wish to erase the contents in the CD-RW disc, press [NO].

---

**10**

If the song holds a large amount of data that cannot be contained on a single CD-RW disc, the disc is ejected, and the message "Insert Disc #" (# indicates the number in the order of insertion) appears in the display to check the total amount of necessary discs. Insert the next CD-RW disc and press [YES]. At this time, we recommend that you write the disc numbers on the labels so that you can keep track of the order in which the discs were inserted into the drive.

---

**11**

When copying over multiple CD-RW discs, "Insert Disc #" (# indicates the number in the order of insertion) appears in the display. Insert each of the discs once more in the proper order and press [YES].

---

**12**

When the CD-R backup procedure is finished, the VS-880 returns to Play mode.

---



## Restoring songs from a CD-RW disc (CD-R Recover)

### Specifying the speed of recovery (Speed)

You can specify the speed at which the data will be read when recovering a song from a CD-RW disc.

### Recovery procedure

- 1** Select the disk (internal IDE hard disk) containing the song you want to load as the current drive.
- 2** Place the CD-R disc to which the song data has been backed up in the CD-RW drive.
- 3** Press [SONG] several times until "CD-R Recover ?" appears in the display.
- 4** Press [YES]. "STORE Current?" (Store the current song?) appears in the display.
- 5** If you wish to save the current song, press [YES]; if not, then press [NO]. If you have selected a demo song, then press [NO].
- 6** "CDR Rcv=" appears in the display. Use the TIME/VALUE dial to select the song (only one song or all songs on the CD-RW disc) that you wish to load, and press PARAMETER [▶▶]. To recover all songs from the current drive, select "All".

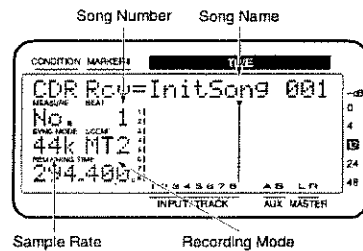

Total number of songs backed up to CD-R (3 songs)

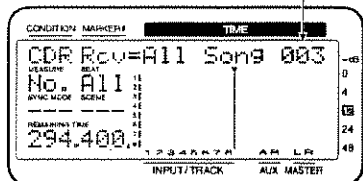

- 7** "CD Speed=" appears in the display. Rotate the TIME/VALUE dial.

SNG CD Speed × 1

**CD Speed**

Select the speed at which the song data will be recovered from disc:

- x6: Recover at 6x speed.
- x2: Recover at double speed.
- x1: Recover at normal speed. This will allow greater reliability.



*Depending on the disc, it may not be possible to recover reliably from some CD-R discs at speeds of "x6" or "x2". In this case, select "x1". Even if the "CD Speed" is set to "x2" or "x6" the time it takes for recovery is not always 1/2 or 1/6 of the base. This is because writing to the internal hard disk can take a lot of time, or disc read errors can sometimes occur.*

- 8** Press [YES].

- 9** If you selected "All" in Step 6, the display will indicate "INIT \*\*\*:\* OK ?" (OK to initialize the disk drive?). "\*\*\*:\*" is the ID number and partition number of the recover destination disk drive. For example, when recovering to partition 0 of the internal hard disk drive, the display would indicate "IDE:0."

- 10** If you wish to initialize the current drive and then recover, press [YES]. If at this point you press [YES], all songs saved on the internal hard disk will be lost. If you decide not to initialize, press [NO]. Normally you should press [NO].

- 11** Execute the load. If the backup spans multiple discs, the disc is ejected, and "Insert Disc #"—"#" indicates the number in the order of insertion—appears in the display. Insert the next disc and press [YES].

- 12** When the CD-R recover procedure is finished, the VS-880 returns to Play mode.

**How to erase the data in the CD-RW disc**

It is impossible to write audio data to the CD-RW discs on which song data is saved. To write audio data to a finalized CD-RW disc, erase the existing data as follows.

1. Place the CD-RW disc that includes the data you wish to erase in the CD-RW drive.
2. Press [SONG] several times until "CD-R Backup?" appears in the display.
3. Press [YES] and "STORE Current?" appears.
4. Press [YES] to save the current song, or [NO] if not. If the current song is the demo song, press [NO]. "CDR Bac=" appears in the display.
5. Press [YES] and "Finalized CD!" or "Not Blank CD!" appears.
6. Press [ENTER (YES)] and "CD-RW Erase?" appears.
7. Press [YES] and "CD-RW Erasing..." appears and the contents of the CD-RW disc are erased.
8. "Continue?" appears and press [NO].

# If You Are Using the VS-1680/VS-880EX

If you use the VS-1680 V-XPANDED or VS-880EX Ver.2.0 or later, you can connect the VS-CDRII to them now. Please refer to the respective *Owner's Manual* for operation instructions.

If your VS-1680 uses system software earlier than Ver.2.0, please update the VS-1680 by following the procedure "To Update the VS-1680" on p. 44.

If your VS-880EX uses system software earlier than Ver.2.0, please update the VS-880EX by following the procedure "To Update the VS-880EX" on p. 48.

You can use special SMFs (Standard MIDI Files) to add the CD-R capability to your VS-Series recorder. You can download the necessary SMFs from the Roland Website—[www.rolandus.com](http://www.rolandus.com). If you'd prefer to perform the update from an external Zip drive, you can also download an updater file that can be copied to a Zip disk. You can also order update disks directly from Roland. To do so, please call Customer Service at 323-890-3700 ext. 2289 and request one of the following:

#### VS-1680

Zip® Disk update—Part # 10838

SMF (PC) update—Part # 10839

SMF (Mac) update—Part # 10840

#### VS-880EX

Zip® Disk update—Part # 10841

SMF (PC) update—Part # 10842

SMF (Mac) update—Part # 10843



*The VS-CDRII package does not include the owner's manuals for VS-1680 V-XPANDED or VS-880EX Ver.2.0. Please call your nearest Roland Service Center or authorized Roland distributor in your country as shown at the end of this manual.*

You can rewrite the contents of a CD-RW disc. To do this, you must first delete the contents of the disk, and then save new different data. For example, it is impossible to save the additional data to a CD-RW disc on which song data is currently stored.

You can also write audio data to a CD-RW disc, but you cannot play it back on a conventional CD player, even after the disc is finalized. In such cases, you can listen to the audio data using the VS-Series CD Player function. You can rewrite the audio data on the CD-RW disc, so it's a good idea to write your data to a CD-RW disc and audition before you write it to CD-R disc.

# To Update the VS-1680

You can update the VS-1680 using special SMFs played into the VS-1680 from an external MIDI sequencer, or by using an external Zip drive. Both types of updater files can be downloaded from the Roland Website—[www.rolandus.com](http://www.rolandus.com). If you do not have Internet access, contact your local Roland dealer, or call Roland's Customer Service department at (323) 890-3700, ext. 2289.

**NOTE**

*After you have upgraded the VS-1680, you can continue using the hard disk that you are currently using without any changes. It is not necessary to initialize the hard disk. However, as a precaution against unforeseen accidents, we recommend that you back up your song data before performing the upgrade.*

**NOTE**

*If you purchased the VS-1680 V-XPANDED, you're ready to use the VS-CDRII; see your Owner's Manual.*

## Updating Using SMFs

To update the VS-1680 using SMFs, prepare the following items:

- VS-1680
- external MIDI sequencer capable of loading and playing SMF files
- MIDI cable
- system update SMF files

- 1** Connect the MIDI OUT port of the sequencer to the MIDI IN port of the VS-1680.
- 2** Hold down TRACK SELECT/CH EDIT button 7 and STATUS button 7 while powering on the VS-1680. The message "System Update?" will be displayed.
- 3** Press YES. The message "Waiting MIDI-EX" will be displayed.
- 4** Load the appropriately formatted Standard MIDI Files into your sequencer.
- 5** Play all of the Standard MIDI Files: "VS168001.mid" through "VS168016.mid," in sequential order. After all SMFs have been played into the VS-1680, the message "Update SysPRG?" will be displayed.
- 6** Press YES. The message "Please Reboot OK" will be displayed. The system software of the VS-1680 has now been updated.
- 7** Restart the VS-1680 (power off and then on again). The new system version will be displayed as the unit is booting up.

## Computer Sequencer Troubleshooting Tips

If you have problems updating your unit with a computer sequencer, the first place to look is your MIDI/interface setup. A MIDI interface connects MIDI devices to your computer. The setup procedure for your MIDI interface will vary depending on the type of interface and computer you are using. On the Macintosh, MIDI interfaces are usually connected to the printer, modem, or USB port(s). The interface is then controlled by either the sequencing software itself or by one of three programs: Apple MIDI Manager, OMS (Opcode), or FreeMIDI (Mark of the Unicorn). On Windows-based computers, MIDI interfaces are usually connected to the serial port, parallel port, USB port, or directly to a sound card. Each interface will probably have its own software drivers that must be installed and configured for the interface to operate correctly.

If you are having trouble getting your MIDI interface to work properly, there are a number of common troubleshooting techniques you can use to determine where the problem lies. On the Macintosh, most setup problems are the result of conflicting extensions in your System Folder. Try disabling any extensions that are not absolutely necessary for the program to run and restart your computer. On Windows computers, most setup problems are the result of conflicting IRQ and/or Port Address settings. Make sure that each of the devices connected to your computer is set to its own IRQ and Port Address and that the corresponding software driver(s) reflects those settings. Defective or incorrectly connected MIDI cables are another common problem encountered when configuring a MIDI sequencing setup.

## Using an Updater on a Zip disk

To use an external Zip drive to update your VS-1680, prepare the following items:

- VS-1680
- SCSI Zip drive
- Zip disk containing the desired system updater

**1** Make sure that the power is turned off on all devices.

**NOTE**

*To prevent malfunction and/or damage to speakers or other devices, always turn down the volume, and turn off the power on all devices before making any connections.*

**2** Disconnect all cables that were connected to the VS-1680.

**3** Connect the SCSI Zip drive to the VS-1680. On the back of the Zip drive, make sure the termination switch is set to 'on'.

**NOTE**

*Have only the SCSI Zip drive connected. Do not connect any other SCSI drives.*

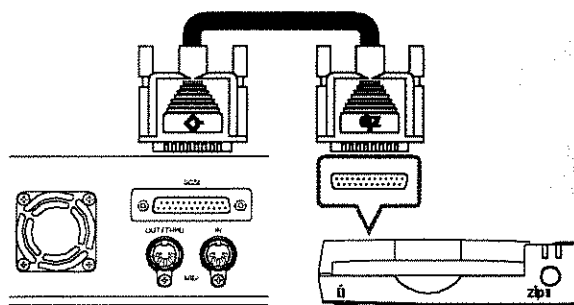

**4** Turn on the power of the SCSI zip drive.

**5** Insert the Zip disk containing the system updater into the SCSI Zip drive.

**6** Connect the power cable to the VS-1680.

**7** Turn on the rear panel power switch of the VS-1680.



**8** Wait for the display to prompt "Update System Program?" and then press [YES].

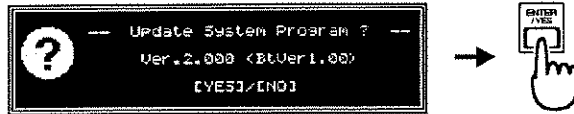

**MEMO**

*If this display does not appear, the VS-1680 was not able to recognize the updater on the Zip disk. Turn off the power, re-insert the disk correctly, and turn the power on once again.*

**9** A message will ask whether you wish to keep the user settings that are stored in your VS-1680. Press [YES] and proceed to Step 11. If you wish to initialize (erase) the user settings, press [NO], and proceed to Step 10.

The user settings that can be left in the VS-1680 are as follows.

- Easy routing (*VS-1680 Owner's Manual*, p. 41)
- Effect user patches (*VS-1680 Owner's Manual*, p. 110)
- Alarm function message (*VS-1680 Owner's Manual*, p. 193)



**10** If you pressed [NO] in Step 9, an additional message will ask you to confirm. If you wish to erase (initialize) the user settings, press [YES]. If you press [NO] you will return to Step 9.

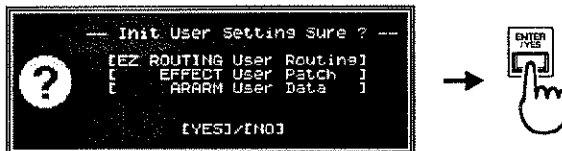

**11** The expansion procedure will begin. Please wait for approximately 30 seconds.

**NOTE**

*You must never under any circumstances turn off the power until the function expansion procedure has been completed. Doing so could damage the VS-1680 system.*

Now Working...0A

- 
- 12** Once the following message appears, you may turn off the power. Verify that this message has appeared, and then turn off the rear panel power switch.

Please Reboot OK

- 
- 13** Turn on the power once again. Verify on the display that the system software is now 2.00 or higher.

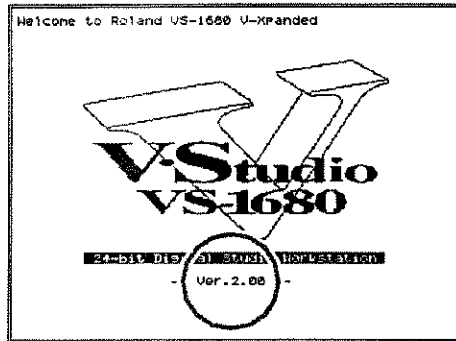

*After updating, you will not need the Zip disk containing the system updater when starting up the VS-1680. Keep this Zip disk in a safe location that is not excessively warm. The Zip disk cannot be used on any device other than the VS-1680.*

# To Update the VS-880EX

You can update the VS-880EX using special SMFs played into the VS-880EX from an external MIDI sequencer, or by using an external Zip drive. Both types of updater files can be downloaded from the Roland Website: [www.rolandus.com](http://www.rolandus.com). If you do not have Internet access, contact your local Roland dealer, or call Roland's Customer Service department at (323) 890-3700, ext. 2289.

**NOTE**

*After you have upgraded the VS-880EX, you can continue using the hard disk that you are currently using without any changes. It is not necessary to initialize the hard disk. However, as a precaution against unforeseen accidents, we recommend that you back up your song data before performing the upgrade.*

**NOTE**

*If you purchased the VS-880EX V-XPANDED, you're ready to use the VS-CDRII; see your Owner's Manual.*

## Updating Using SMFs

To update the VS-880EX using SMFs, prepare the following items:

- VS-880EX
- external MIDI sequencer capable of loading and playing SMF files
- MIDI cable
- system update SMF files

- 1** Connect the MIDI OUT port of the sequencer to the MIDI IN port of the VS-880EX.
- 2** Hold down [CH EDIT (SEL)] and [STATUS] on Track 7 while powering on the VS-880EX. The message "System Update?" will be displayed.
- 3** Press YES. The message "Waiting MIDI-EX" will be displayed.
- 4** Load the Standard MIDI Files into your sequencer.
- 5** Play all of the Standard MIDI Files: "880EX\_01. MID" to "880EX\_16. MID" in order. After all SMFs have been played into the VS-880EX, the message "Update SysPRG7" will be displayed.
- 6** Press YES. The message "Please Reboot OK" will be displayed. The system software of the VS-880EX has now been updated.
- 7** Restart the VS-880EX (power off and then on again). The new system version will be displayed as the unit is booting up.

## Computer Sequencer Troubleshooting Tips

If you have problems updating your unit with a computer sequencer, the first place to look is your MIDI/interface setup. A MIDI interface connects MIDI devices to your computer. The setup procedure for your MIDI interface will vary depending on the type of interface and computer you are using. On the Macintosh, MIDI interfaces are usually connected to the printer, modem, or USB port(s). The interface is then controlled by either the sequencing software itself or by one of three programs: Apple MIDI Manager, OMS (Opcode), or FreeMIDI (Mark of the Unicorn). On Windows-based computers, MIDI interfaces are usually connected to the serial port, parallel port, USB port, or directly to a sound card. Each interface will probably have its own software drivers that must be installed and configured for the interface to operate correctly.

If you are having trouble getting your MIDI interface to work properly, there are a number of common troubleshooting techniques you can use to determine where the problem lies. On the Macintosh, most setup problems are the result of conflicting extensions in your System Folder. Try disabling any extensions that are not absolutely necessary for the program to run and restart your computer. On Windows computers, most setup problems are the result of conflicting IRQ and/or Port Address settings. Make sure that each of the devices connected to your computer is set to its own IRQ and Port Address and that the corresponding software driver(s) reflects those settings. Defective or incorrectly connected MIDI cables are another common problem encountered when configuring a MIDI sequencing setup.



## Using an Updater on a Zip disk

To use an external Zip drive to update your VS-880EX, prepare the following items:

- VS-880EX
- SCSI Zip drive
- Zip disk containing the desired system updater

**1** Make sure that the power is turned off on all devices.

**NOTE**

*To prevent malfunction and/or damage to speakers or other devices, always turn down the volume, and turn off the power on all devices before making any connections.*

**2** Disconnect all cables that were connected to the VS-880EX.

**3** Connect the SCSI Zip drive to the VS-880EX. On the back of the Zip drive, make sure the termination switch is set to 'on'.

**NOTE**

*Have only the SCSI Zip drive connected. Do not connect any other SCSI drives.*

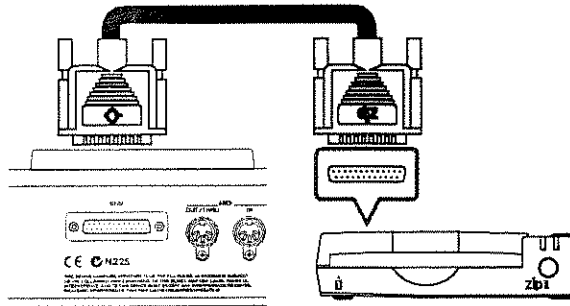

**4** Turn on the power of the SCSI zip drive.

**5** Insert the Zip disk containing the system updater into the SCSI Zip drive.

**6** Connect the power cable to the VS-880EX.

**7** Turn on the rear panel power switch of the VS-880EX.



**8** Wait for the display to prompt "Update System Program?" and then press [YES].

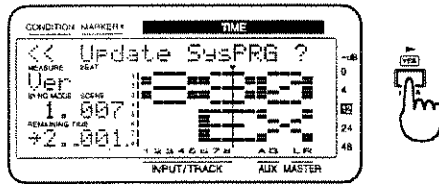

*If this display does not appear, the VS-880EX was not able to recognize the updater on the Zip disk. Turn off the power, re-insert the disk correctly, and turn the power on once again.*

**9** A message will ask whether you wish to keep the user settings that are stored in your VS-880EX. Press [YES] and proceed to Step 11. If you wish to initialize (erase) the user settings, press [NO], and proceed to Step 10.

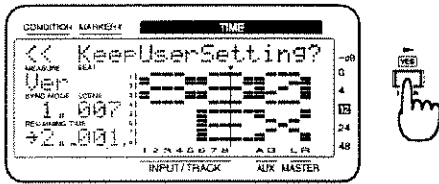

The user settings that can be left in the VS-880EX are as follows.

- Effect user patches (*VS-880EX Owner's Manual*, p. 70)
- Easy routing (*VS-880EX Owner's Manual*, p. 74)

**10** If you pressed [NO] in Step 9, an additional message will ask you to confirm. If you wish to erase (initialize) the user settings, press [YES]. If you press [NO] you will return to Step 9.

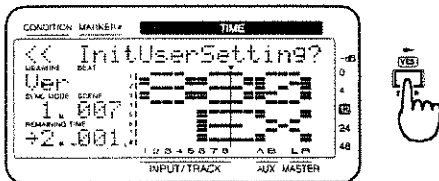

- 11** The expansion procedure will begin. Please wait for approximately 30 seconds.

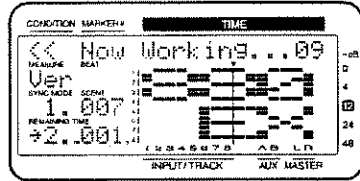

*You must never under any circumstances turn off the power until the function expansion procedure has been completed. Doing so could damage the VS-880EX system.*

- 12** Once the following message appears, you may turn off the power. Verify that this message has appeared, and then turn off the rear panel power switch.

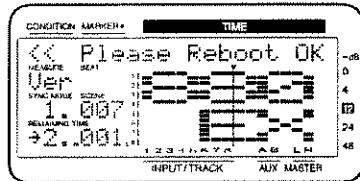

- 13** Turn on the power once again. Verify on the display that the system software is now 2.00 or higher.

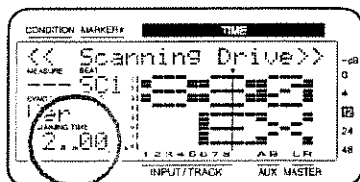

*After updating, you will not need the Zip disk containing the system updater when starting up the VS-880EX. Keep this Zip disk in a safe location that is not excessively warm. The Zip disk cannot be used on any device other than the VS-880EX.*

# Appendices

## Terminators

The device at each end of a SCSI chain must have a terminator (a terminating resistance). Since the VS-Series recorder is one end of the SCSI chain, it contains an internal terminator. This means that a terminator must be connected only to the external drive which is on the other end of the chain. For details on attaching a terminator, refer to the owner's manual of your disk drive.

## SCSI ID numbers

Each disk drive is distinguished by its SCSI ID number (0-7). This means that when two or more disk drives are connected, you must set them so that the SCSI ID numbers of the disk drives do not coincide, and thus cause a conflict. If the SCSI ID numbers conflict, the VS-Series recorder will not be able to correctly recognize the disk drives.



*With the factory settings, the VS-Series recorder is set to SCSI ID number 7. Set the disk drives you are connected to ID numbers other than 7.*

## Troubleshooting

You are unable to make digital connections.

- Digital connections are not available with the current setup (p. 19).

The CD-RW drive is not being recognized.

- The drive is not properly connected.
- There is no CD-R disc in the drive.

You are unable to write to the CD-R.

- The song sample rate is set to something other than 44.1 kHz (p. 14).
- There is insufficient free space on the internal IDE hard disk (p. 33).
- There is insufficient free space on the CD-R disc.
- The write procedure being conducted is for ordinary commercial CD software, or you are trying to write to ordinary commercial CD software.
- You are trying to write to a CD-R disc that has already been finalized.

## Q & A

Q	A
I purchased VS-CDRII, and I want to start using it right away. What should I do?	A certain amount of preparation is required before you can use the VS-CDRII. You must first make sure you have the following items: <ul style="list-style-type: none"><li>• VS-880 with system software 3.20A or higher</li><li>• VS-880 internal hard disk drive unit (HDP88 series)</li><li>• VS-CDRII drive</li><li>• Recording equipment, e.g. instruments, microphone, CD player</li><li>• Audio equipment for master out, stereo headphones</li><li>• CD-R discs, Etc.</li></ul>
Is a Zip drive absolutely necessary?	A Zip drive is only necessary for updating the system and switching between SYSTEM-A and -B if you don't have an external SMF-compliant sequencer to use for these tasks.

## About SCSI

Q	A
What are the provided floppy disks for?	They can update your system software to add CD-R capability to your VS-880. For more about the procedure for adding this capability, please read "Adding CD-R Capability to the VS-880 (V-XPANDED CD)" (p. 8).
Can the floppy disks be used with any personal computer or stand-alone sequencer?	The floppy disks can be used in any computer or stand-alone sequencer that uses the Windows or Macintosh format.
I have original effects patches in my unit. Will these effects patches be lost when CD-R capability is added?	No. Your effects patches can be used just as before, even after installation of the additional capabilities.
I tried to record a regular audio CD from the DIGITAL IN connector, but the message "Can't REC CD!" appeared on the screen. What happened?	The VS-CDRII's digital connectors are disabled during normal operations with the VS-880. Please read "To Record Digital Signals" (p. 19).
What kind of discs can I use?	You can use all CD-R discs, regardless of recording time. However, CD-RW discs cannot be used.
Can song data be written in Macintosh AIFF file format?	No. The CD-R drive only supports audio CD format.
Can I use the VS-880 to write Roland Sampler S series CD-ROMs (e.g., L-CD701)?	No. VS-CDRII only supports audio CD format.
How long does it take to make one CD?	That depends on the time it takes to record the songs. Take a look at the following relationships. Preparing the image data file: approximately twice the actual playing time Writing to the CD-R disc: roughly half the actual playing time
Can I record via the SCSI connector with third-party CD software in the CD-R drive?	No. You will need to use a regular CD player.
While converting the song data to an image data file, the VS-880's power was accidentally turned off. Now what?	This has no effect on the CD-R disc. Carry out the procedure described in "Making an Original CD" (p. 29) once more. However, the VS-880's song data reverts to the state it was in the last time song store was carried out.
While writing to the CD-R disc, the VS-880's power was accidentally turned off. What is the effect?	Unfortunately, that CD-R disc is now unusable. Insert a new CD-R disc, and carry out the procedure described in "Making an Original CD" (p. 29) once more.
Can't audio CDs made on the VS-880 be played on ordinary CD players?	Yes, if you perform the finalize procedure. Please read "Writing the Song Data (Finalize)" (p. 32).
Can I play commercially available CD titles?	Yes. Please read "Listening to the Songs You Have Written (CD Player Mode)" (p. 35).
Is it normal for no sound to be output from the CD-R drive's headphone jack or AUDIO OUT jack when using the CD player feature?	No sound is output from the CD-R drive's PHONES jack or AUDIO OUT jack. To monitor the sound, use the VS-880's MASTER OUT jack or PHONES jack.
Can I make a digital connection with devices such as DAT recorders to play audio CDs made on the CD-R drive?	Audio CDs made on the CD-R drive are SCMS-compatible. Accordingly, you can make only first-generation recordings when using digital connections. For more detailed information about SCMS, please read "About SCMS" (p. 56).

---

## List of Messages

Following are the meaning of messages that appear in the VS-880's display.

### **Blank Disc**

You have tried to run the CD player function using a disc that has no performance data on it. Insert a commercial CD or CD-R with material already recorded on it.

### **CD-R Finalizing**

The finalize process is in progress. Please wait a few moments for it to finish.

### **CD-R Not Ready!**

Either the CD-R drive loading tray is still open, there is no CD-R disc loaded, or the CD-R drive is otherwise not ready.

### **CD-R Writing \*\*%**

Song data is being written to the CD-R disc.

### **Can't REC CD!**

With the CD-R capability installed, digital connections cannot be made with a CD player. Please read "To Record Digital Signals" (p. 19).

### **Can't Set Marker**

No more than two track number mark points can be set within a four-second interval.

### **Converting \*\*%**

The song data on the hard disk is being converted to a CD-R disc image data file.

### **Change Int CLK ?**

No digital signal is being received at the DIGITAL IN connector. Select whether or not to switch the sample rate reference clock to the internal clock. Pressing [YES] switches the VS-880 to the internal clock. After checking to make sure that all digital devices are properly connected and that sample rates for all devices match, carry out the operation once more.

► *V-XPANDED Owner's Manual* (p. 72)

### **Complete**

The procedure has finished normally.

### **Digital In Lock**

The sample rate reference clock is set to the digital signal coming from the DIGITAL IN connector. You can record using the digital connection.

► *V-XPANDED Owner's Manual* (p. 72)

### **Digital In Unlock**

The digital signal is not being input through the DIGITAL IN connector, or the sample rate set for the song and the sample rate of the digital device connected to the DIGITAL IN connector are different. In this state, you cannot record using the digital connection.

► *V-XPANDED Owner's Manual* (p. 72)

### **Finalized CD!**

This message appears when an attempt is made to write to a commercial CD or a finalized CD-R disc. Replace the disc with a blank disc or one that has not been finalized.

### **Lack of CD-R Mem**

There is insufficient free space to write the songs to the CD-R disc.

### **Lack of IDE Mem**

There is insufficient free space on the internal IDE hard disk to make the image data file.

### **No CD-R Drive!**

Either no CD-R drive is connected, or the drive's power is not turned on.

### **No Data to Write**

The track that you have selected to write to disc contains no song data.

### **No Disc**

There is no disc in the CD-R drive. Please insert a disc.

### **No IDE Drive!**

The unit has no IDE-type disk drive. Install an internal hard disk.

► *Quick Start* (p. 2)

### **Not 44.1k Song!**

The sample rate of the song is not 44.1 kHz, so the data cannot be written to the CD-R disc.

### **Obey Copyrights?**

This message asks if you agree to the terms and conditions regarding the reproduction, broadcast, and sale of the software. Please carefully read the License Agreement (p. 56).

### **Please Wait...**

Operation is in progress. Please wait momentarily.

### **Scanning CD-R**

The CD-R is being scanned. Please wait momentarily.

### **TOC Read Error!**

An error occurred in reading from the CD-R disc. There is a problem with the CD-R drive or the CD-R disc.

### **Too Many Marker(s)!**

You have tried to set track number mark points in excess of the maximum (98) you can set for one disc.

### **Write Another?**

Writing to the disc is complete. Select whether or not you want to write the same data to a new disc. Press [YES] or [NO].

---

## Glossary/List of Terms

### CD-R

Short for **Compact Disc Recordable**. This is a system for reading and writing discs in the same format as that used for CDs (CD-ROMs and music CDs). A specialized CD-R drive allows one-time only writing of discs.

However, as long as the data has not been finalized and there is sufficient capacity remaining on the disc, the CD-R drive can be used for multiple additions to, and changes in the material.

Sometimes they are referred to as "Write-Once CD," "CD-Write Once," or something similar.

### CD Player Mode

This feature runs the CD-R drive as a CD player so data can be checked before it is finalized. The sound is output from the VS-880's MASTER OUT jack and PHONES jack. No sound is output from the CD-R drive's AUDIO OUT jack or PHONES jack.

### Finalize

This is the operation that writes the TOC to a prepared audio disc. Whereas additions and changes can be made to discs that have not yet been finalized, such discs are not playable on regular CD players.

### IDE

IDE stands for **Integrated Device and Electronics**. This is the standard data transmission method used by the hard disk drives of recent personal computers. The HDP88 series hard disk drives (sold separately) that can be installed in the VS-880 are IDE-compatible.

### TOC

Short for **Table of Contents**. This is the region on the CD-R disc that handles information such as song times, end times, sequence, and so on. Although the songs on a disc and their playing time can be displayed when an audio CD is placed in a CD player, this is because they can be read automatically from the TOC. The TOC is recorded differently than music data, with its main characteristic being disc access, such as the ability to go to the start of any song instantly.

### S/PDIF

S/PDIF stands for **Sony/Philips Digital Interface Format**. This is a specification for transmitting and receiving stereo digital audio signals between digital audio devices. The VS-880 provides coaxial connectors which support S/PDIF.

### SCMS

SCMS stands for **Serial Copy Management System**. This is a function that protects the rights of copyright holders by prohibiting recording via a digital connection of more than one copy. When digital connections are made between digital recorders that implement this function, SCMS data will be recorded along with the audio data. Digital audio data which contains this SCMS data cannot again be recorded via a digital connection.

### SCSI

SCSI stands for **Small Computer System Interface**. This is a data transmission method that can transmit large amounts of data in a short time. Since the VS-880 has a SCSI connector, external SCSI devices such as hard disks or removable disk drive etc. can be connected.

### Zip Drive

A magnetic disk drive format standardized by Iomega Corporation. Disks that can be used for reading and writing data with Zip drives are called Zip disks. Similar to 3.5-inch floppy disks in size and usage, one Zip disk can store 100 MB of data.

---

## Index

Auto mix.....	21	Recording mode.....	14
CD player Mode.....	35	Sample rate.....	14
CD-R disc.....	3	SCMS.....	54
Effect.....	8	SCSI.....	53
Finalize.....	32	SMF.....	8
IDE.....	28	TOC.....	53
Metronome.....	15	Track Bouncing.....	20
Overdubbing.....	18	Track number.....	30
Punch-in.....	18	Zip drive.....	9
Punch-out.....	18		

### Concerning Copyright

The law prohibits the unauthorized recording, public performance, broadcast, sale, or distribution etc. of a work (CD recording, video recording, broadcast, etc.) whose copyright is owned by a third party.

The VS-880 does not implement SCMS. This design decision was made with the intent that SCMS should not restrict the creation of original compositions which do not violate copyright law. Roland will take no responsibility for any infringement of copyright that you may commit in using the VS-880.

### About SCMS

SCMS stands for **Serial Copy Management System**. This is a function that protects the rights of copyright holders by prohibiting recording via a digital connection of more than one copy. When digital connections are made between digital recorders that implement this function, SCMS data will be recorded along with the audio data. Digital audio data which contains this SCMS data cannot again be recorded via a digital connection.

### About the License Agreement

The VS-880 and its CD-R capability are designed to allow you to reproduce material to which you have copyright, or material which the copyright owner has granted you permission to copy. Accordingly, reproduction of music CDs or other copyrighted material without the permission of the copyright owner, other than for your own personal use and enjoyment (private use) constitutes copyright infringement, which may incur penalties. Consult a copyright specialist or special publications for more detailed information on obtaining such permission from copyright holders.

*\* In the interest of product improvement, the specifications and/or contents of this package are subject to change without prior notice.*





## Information

When you need repair service, call your nearest Roland Service Center or authorized Roland distributor in your country as shown below.

### AFRICA

**EGYPT**  
Al Fanny Trading Office  
P.O. Box 2904,  
El Horrieh Heliopolis, Cairo,  
EGYPT  
TEL: (02) 4185531

**REUNION**  
Maison FO - YAM Marcel  
25 Rue Jules MirmanZL  
Claudron - BP79 97491  
Site Clotilde REUNION  
TEL: 28 29 16

**SOUTH AFRICA**  
That Other Music Shop  
(PTY) Ltd.  
11 Mills Street (Cnr Melie and  
Juta Street)  
Bramfontein 2001  
Republic of SOUTH AFRICA  
TEL: (011) 403 4105

Paul Bothner (PTY) Ltd.  
17 Werdmuller Centre Claremont  
7700  
Republic of SOUTH AFRICA

P.O. Box 23032  
Claremont, Cape Town  
SOUTH AFRICA, 7735  
TEL: (021) 64 4030

### ASIA

**CHINA**  
Beijing Xinghai Musical  
Instruments Co., Ltd.  
6 Huangmuyuchang Chao Yang  
District, Beijing, CHINA  
TEL: (010) 6774 7491

**HONG KONG**  
Tom Lee Music Co., Ltd.  
Service Division  
22-32 Sun Shan Street, Tsuen  
Wan, New Territories,  
HONG KONG  
TEL: 2415 0911

**INDIA**  
Rivera Digitec (India) Pvt. Ltd.  
409, Nirman Kendra Mahalaxmi  
Flats Compound Off. Dr. Edwin  
Moses Road, Mumbai-400011,  
INDIA  
TEL: (022) 498 3079

**INDONESIA**  
PT Citra Inti Rama  
Jl. Cideng Timur No. 151-150  
Jakarta Pusat  
INDONESIA  
TEL: (021) 6324170

**KOREA**  
Cosmos Corporation  
Service Station  
261 2nd Floor Nak-Won Arcade  
Jong-Ro Icu, Seoul, KOREA  
TEL: (02) 742 8844

**MALAYSIA**  
Bentley Music SDN BHD  
140 & 142, Jalan Bukit Bintang  
55100 Kuala Lumpur, MALAYSIA  
TEL: (03) 2443333

**PHILIPPINES**  
G.A. Yupangco & Co. Inc.  
309 Gil J. Puyat Avenue  
Makati, Metro Manila 1200,  
PHILIPPINES  
TEL: (02) 899 9801

**SINGAPORE**  
Swee Lee Company  
150 Sims Drive,  
SINGAPORE 387381  
TEL: 748-1669

**CRISTOFORI MUSIC PTE  
LTD**  
Blk 3014, Bedok Industrial Park E,  
#02-2148, SINGAPORE 489980  
TEL: 243 9555

**TAIWAN**  
ROLAND TAIWAN  
ENTERPRISE CO., LTD.  
Room 5, 9th Fl. No. 112 Chung Shan  
N. Road Sec.2, Taipei, TAIWAN,  
R.O.C  
TEL: (02) 2561 3339

**THAILAND**  
Theera Music Co., Ltd.  
330 Verng NakomKasem, Soi 2,  
Bangkok 10100, THAILAND  
TEL: (02) 2248621

**VIETNAM**  
Saigon Music  
138 Tran Quang Khai St.,  
District 1  
Ho Chi Minh City  
VIETNAM  
TEL: (08) 844-4066

### AUSTRALIA/ NEW ZEALAND

**AUSTRALIA**  
Roland Corporation  
Australia Pty., Ltd.  
38 Campbell Avenue  
Dee Why West, NSW 2099  
AUSTRALIA  
TEL: (02) 9982 8266

**NEW ZEALAND**  
Roland Corporation (NZ) Ltd.  
97 Mt. Eden Road, Mt. Eden,  
Auckland 3, NEW ZEALAND  
TEL: (09) 3098 715

### CENTRAL/LATIN AMERICA

**ARGENTINA**  
Instrumentos Musicales S.A.  
Florida 656 2nd Floor  
Office Number 206A  
Buenos Aires  
ARGENTINA, CP1005  
TEL: (54-11) 4- 393-6057

**BRAZIL**  
Roland Brasil Ltda.  
R. Carmel Octaviano da Silveira  
203 05522-010  
Sao Paulo BRAZIL  
TEL: (011) 3743 9377

**CHILE**  
Comercial Fancy S.A.  
Avenida Rancagua #0330  
Providencia Santiago, CHILE  
TEL: 56-2-373-9100

**EL SALVADOR**  
OMNI MUSIC  
75 Avenida Notre y Alameda  
Juan Pablo 2 No. 4010  
San Salvador, EL SALVADOR  
TEL: (503) 262-0786

**MEXICO**  
Casa Veerkamp, s.a. de c.v.  
Av. Toluca No. 323 Col. Olivar de  
los Padres 01780 Mexico D.F.  
MEXICO  
TEL: (525) 668 04 80

La Casa Wagner de  
Guadalajara s.a. de c.v.  
Av. Corona No. 202 S.J.  
Guadalajara, Jalisco Mexico  
C.P.44100 MEXICO  
TEL: (3) 613 1414

**PANAMA**  
Productos Superiores, S.A.  
Apartado 655 - Panama 1  
REP. DE PANAMA  
TEL: (507) 270-2200

**URUGUAY**  
Todo Musica  
Cuareim 1488, Montevideo,  
URUGUAY  
TEL: 5982-924-2335

**VENEZUELA**  
Musiland Digital C.A.  
Av. Francisco de Miranda,  
Centro Parque de Cristal, Nivel  
C1 Local 20 Caracas  
VENEZUELA  
TEL: (02) 285 9216

### EUROPE

**AUSTRIA**  
Roland Austria GES.M.B.H.  
Siemensstrasse 4, P.O. Box 74,  
A-6063 RUM, AUSTRIA  
TEL: (0512) 26 44 260

**BELGIUM/HOLLAND/  
LUXEMBOURG**  
Roland Benelux N. V.  
Houtstraat 3 B-2260 Oevel  
(Westerlo) BELGIUM  
TEL: (014) 575811

**DENMARK**  
Roland Scandinavia A/S  
Nordhavnvej 7, Postbox 880  
DK-2100 Copenhagen  
DENMARK  
TEL: (039) 16 6200

**FRANCE**  
Roland France SA  
4, Rue Paul Henri SPAAK  
Parc de l'Esplanade F 77 462 St.  
Thibault Lagny Cedex FRANCE  
TEL: 01 608 73 500

**FINLAND**  
Roland Scandinavia As.  
Filial Finland  
Lauttaasaarentie 54 B  
Fin-00201 Helsinki, FINLAND  
TEL: (9) 682 4020

**GERMANY**  
Roland Elektronische  
Musikinstrumente  
Handelsgesellschaft mbH.  
Oststrasse 36, 22844 Norderstedt,  
GERMANY  
TEL: (040) 52 6090

**GREECE**  
STOLLAS S.A.  
Music Sound Light  
155, New National Road  
26422 Patras, GREECE  
TEL: 061-435400

**HUNGARY**  
Intermusica Ltd.  
Warehouse Area "DEPO" Fl.83  
H-2046 Torokbalint, HUNGARY  
TEL: (23) 511011

**IRELAND**  
Roland Ireland  
Audio House, Belmont Court,  
Donnybrook, Dublin 4  
Republic of IRELAND  
TEL: (01) 2603501

**ITALY**  
Roland Italy S. p. A.  
Viale delle Industrie, 8  
20020 Arese Milano, ITALY  
TEL: (02) 937-78300

**NORWAY**  
Roland Scandinavia Avd.  
Kuntor Norge  
Lilleakerveien 2 Postboks 95  
Lilleaker N-0216 Oslo  
NORWAY  
TEL: 273 0074

**POLAND**  
P. P. H. Brzostowicz  
UL. Gibraltarska 4  
PL-03664 Warszawa POLAND  
TEL: (022) 679 44 19

**PORTUGAL**  
Tecnologias Musica e Audio,  
Roland Portugal, S.A.  
RUA SANTA CATARINA  
131 - 4000 Porto -PORTUGAL  
TEL: (02) 208 44 56

**ROMANIA**  
FRS LINES  
Plata Libertatii 1,  
RO-4200 Cheorgheni  
TEL: (066) 164-609

**RUSSIA**  
Slami Music Company  
Sadovaya-Triumfalnaja st., 16  
103006 Moscow, RUSSIA  
TEL: 093 209 2193

**SPAIN**  
Roland Electronics  
de Espana, S. A.  
Calle Bolivia 239 08020 Barcelona,  
SPAIN  
TEL: (93) 308 1000

**SWEDEN**  
Roland Scandinavia A/S  
SWEDISH SALES OFFICE  
Danvik Center 28, 2 tr.  
S-131 30 Nacka SWEDEN  
TEL: (08) 702 0020

**SWITZERLAND**  
Roland (Switzerland) AG  
Mustronic AG  
Gerberstrasse 5, CH-4410 Liestal,  
SWITZERLAND  
TEL: (061) 921 1615

**UKRAINE**  
TIC-TAC  
Mira Str. 19/108  
P.O. Box 180  
295400 Mukachevo, UKRAINE  
TEL: (03131) 414-40

**UNITED KINGDOM**  
Roland (U.K.) Ltd.  
Atlantic Close, Swansea  
Enterprise Park SWANSEA  
SA7 9FJ,  
UNITED KINGDOM  
TEL: (01792) 700139

### MIDDLE EAST

**BAHRAIN**  
Moon Stores  
Bab Al Bahrain Road,  
P.O. Box 20077  
State of BAHRAIN  
TEL: 211 005

**CYPRUS**  
Radex Sound Equipment Ltd.  
17 Diagonou St., P.O. Box 2046,  
Nicosia CYPRUS  
TEL: (02) 453 426

**ISRAEL**  
Halilit P. Greenspoon &  
Sons Ltd.  
8 Retzif Fa'aliya Hashnaya St.  
Tel-Aviv-Yahio ISRAEL  
TEL: (03) 6823666

**JORDAN**  
AMMAN Trading Agency  
Prince Mohammed St. P.O. Box  
825 Amman 11118 JORDAN  
TEL: (06) 4641200

**KUWAIT**  
Easa Husain Al-Yousifi  
P.O. Box 126 Safat 13002  
KUWAIT  
TEL: 5719499

**LEBANON**  
A. Chahine & Fils  
P.O. Box 16-5857 Gergi Zeidan St  
Chahine Building, Achrafieh  
Beirut, LEBANON  
TEL: (01) 3357999

**OMAN**  
OHI Electronics & Trading  
Co. LLC  
P.O. Box 889 Muscat  
Sultanate of OMAN  
TEL: 959085

**QATAR**  
Badie Studio & Stores  
P.O. Box 62,  
DOHA QATAR  
TEL: 423554

**SAUDI ARABIA**  
aDawlah Universal  
Electronics APL  
P.O. Box 2154 ALKHOBAR 31952,  
SAUDI ARABIA  
TEL: (03) 898 2081

**SYRIA**  
Technical Light & Sound  
Center  
Khaled Ibn AlWalid St.  
P.O. Box 12520  
Damascus - SYRIA  
TEL: (011) 2235 384

**TURKEY**  
Barkat Muzik aletleri ithalat  
ve ihracat limited ireketi  
Siraselviler Cad. Billurcu Sok  
Mucadelle Cikmeze No. 11-13  
Taksim, Istanbul, TURKEY  
TEL: (0212) 2495324

**U.A.E.**  
Zak Electronics & Musical  
Instruments Co.  
Zabeel Road, Al Sherooq Bldg.,  
No. 14, Grand Floor DUBAI  
U.A.E  
P.O. Box 8050 DUBAI U.A.E.  
TEL: (04) 360715

### NORTH AMERICA

**CANADA**  
Roland Canada Music Ltd.  
(Head Office)  
5480 Parkwood Way Richmond  
B. C., V6V 2M4 CANADA  
TEL: (604) 270 6626

Roland Canada Music Ltd.  
(Toronto Office)  
Unit 2, 109 Woodbine Downs  
Bldg, Etobicoke, ON  
M9W 6Y1 CANADA  
TEL: (0416) 213 9707

**U. S. A.**  
Roland Corporation U.S.  
5100 S. Eastern Avenue  
Los Angeles, CA 90040-2938,  
U. S. A.  
TEL: (323) 890 3700

As of June 11, 1999



**Roland®**

---

**10869**

UPC 10869



10869

**Roland®**