

TR-606

Operation Manual



Important Notes

- This unit features non-volatile memory which will retain the Data you have written (such as Track compositions) even when switched off and disconnected from any external power source. This back-up circuit, however, relies on its batteries, therefore not available if the batteries are flat or not securely connected. Please be sure to keep the batteries securely connected even while using the AC adaptor.

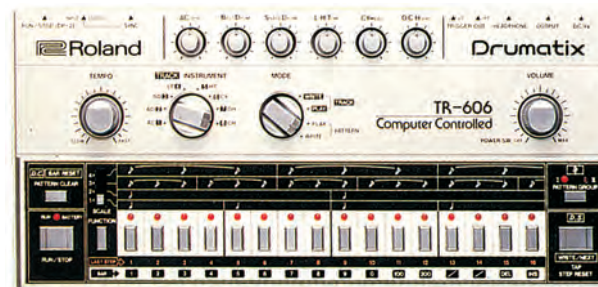

TABLE OF CONTENTS

INTRODUCTION 3
BASIC COURSE 4
Basic Connections 4
Front and Back Panel Layout 6
Writing Rhythm Patterns 7
Playing Rhythm Patterns 13
Composing the Rhythm Track 14
Playing the Rhythm Track 15
ADVANCED COURSE 16
Control Descriptions 16
Other Connections 19
Playing Rhythm Patterns 23
Writing Rhythm Patterns 24
Composing the Rhythm Track 29
Sample Rhythms 34
Specifications 43

INTRODUCTION

The Roland TR-606 is a portable, economical, automatic and fully programmable rhythm device, which can memorize your own rhythms with exceptional flexibility. With it you can write and record different percussive rhythms into non-volatile memory (battery back-up), with up to seven different drum sounds plus accent. Then you can adjust the volume of each percussion sound with individual level controls for full flexibility over the final mix. Programming several rhythms can be accomplished and stored in a particular order in the memory, forming the entire rhythm track of a song. This music can then quite easily be amended, since the TR-606 includes a simple, yet effective, editing facility. In this manual, we shall refer to each bar of music as a "Rhythm Pattern". So, the TR-606 has mainly 2 basic functions. One of them is "Writing/Playing a Rhythm Pattern", the other is "Writing/Playing a Rhythm Track". The former describes the writing of individual bars into computer memory, to be played later, while the latter describes writing the entire rhythm track of a piece of music into computer memory, which also may be played later.

The TR-606 can do all this, and more, so each switch has at least two functions. Furthermore, adjacent Rhythm Patterns may be "chained" together into single, more complex patterns, for divisions as small as sixty-fourth notes, or for more complex time signatures. When using the Track Write function, eight track positions give a maximum of seven different compositions of 64 bars each and one of 256 bars, and can be chained together in various combinations for extended compositions of up to 256 bars each. A programmable D.C. BAR allows you to program the final bar of a Track composition to begin again at the first bar. The TR-606 can be connected to a variety of digital sequencers, synthesizers and other devices for synchronized rhythmic control of sound, expanding its live performance, composing and recording applications. The TR-606 is exceptionally compact, and for maximum portability features battery operation for all functions including a self-contained Headphone Amplifier for monitoring through any Stereo Headphone. For extended battery life, a socket is included on the back panel for connection to an optional Boss ACA Battery Eliminator.

The TR-606 owner's manual has two courses consisting of a Basic Course and an Advanced Course, because these unique functions should be completely understood.

BASIC COURSE

This Basic Course will provide essential information needed to satisfactorily operate the TR-606 Drumatix. For complete information and more complex applications, refer to the Advanced Course Manual.

Basic Connections

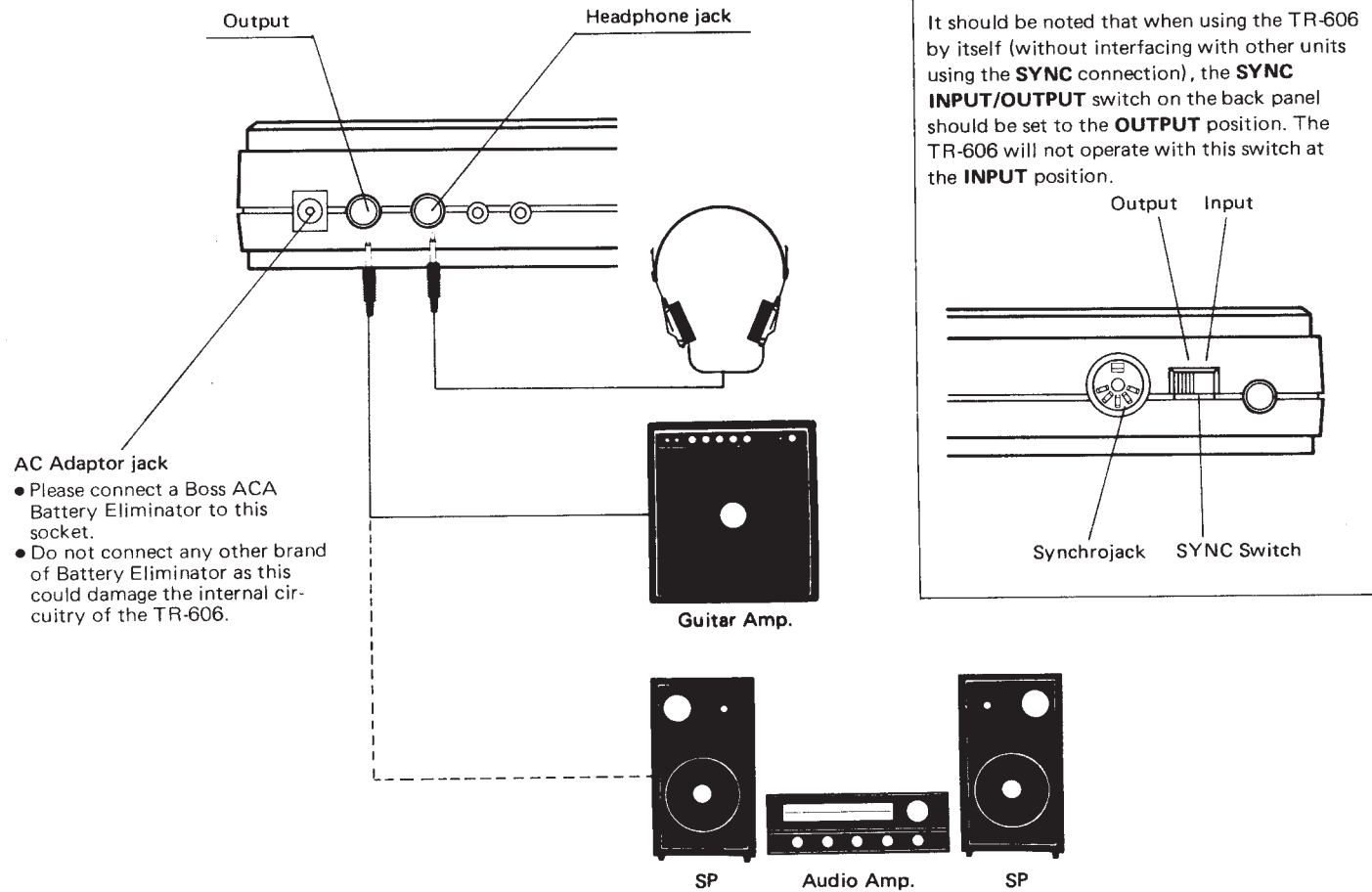

Choosing Amplification

The TR-606 Rhythm Composer may be monitored through any conventional amplification, but ideal amplification will reproduce its realistic drum sounds faithfully with a minimum of added distortion and coloration.

Audio OUTPUT

The **OUTPUT** jack on the back panel of the TR-606 presents the summed output of the individual **INSTRUMENT MIX LEVEL** (E) controls as adjusted by the master **VOLUME** (A) control to allow very precise control over the TR-606 final output level and balance.

HEADPHONE Jack

The TR-606 also provides self-contained amplification for any conventional stereo headphones through a 1/4 inch stereo phone jack on the back panel. The **HEADPHONE OUTPUT** level is controlled by the master **VOLUME** control (A) in combination with the individual **INSTRUMENT MIX LEVEL** (E) controls.

AC ADAPTOR (OPTION)

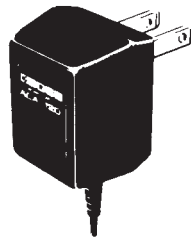

BOSS ACA-120
FOR 117V AC

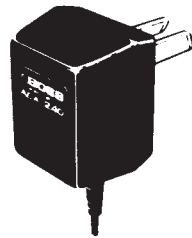

BOSS ACA-240
FOR 240V AC

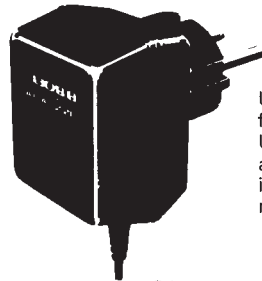

BOSS ACA-220
FOR 220V AC

Use BOSS AC adaptor for AC operation. Use of a different adaptor may cause improper operation or no sound.

Battery Eliminator

The TR-606 is fully portable, normally relying on batteries for all internal functions and to power the self-contained Headphone amplifier. To extend battery life, merely connect a BOSS ACA Battery Eliminator this socket. "CAUTION" Don't connect any other brand of Battery Eliminator, as this could damage the internal circuitry of the TR-606.

CAUTIONS (Refer to below left)

- *When the TR-606 is not in use for long periods, remove the battery to prevent leakage.*
- *If battery voltage drops, effect becomes inferior or no sound is produced. To prevent that, replace the batteries.*
- *Be sure to keep the batteries securely connected, even while using the AC Adaptor.*
- *Even if AC Adaptor cord comes out during performance, if the batteries are connected, the TR-606 will continue to operate.*
- *If this unit is not to be used for long periods of time, please be sure to switch the power off and remove the exhausted batteries, or various troubles may be caused by battery leakage.*

Memory Back-Up

The TR-606 Rhythm Composer features a non-volatile memory which will retain Rhythm Patterns and Track compositions when switched 'OFF' and disconnected from any external power source. The TR-606 relies on its batteries for its back-up circuit to protect these memories. Always replace the TR-606's batteries with a complete set of fresh batteries when the **RUN/BATTERY** Indicator LED (C) either flashes or fails to illuminate during the normal Run condition of the TR-606. If the batteries are changed quickly, within one minute, the memory can retain the DATA.

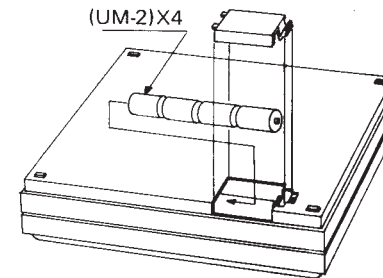
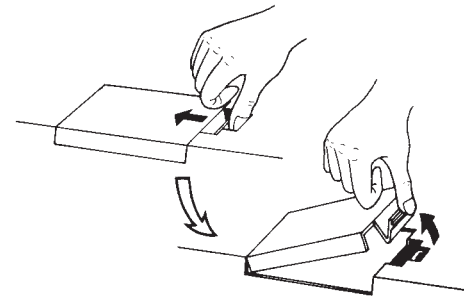

BASIC COURSE (Cont'd)

Front and Back Panel Layout

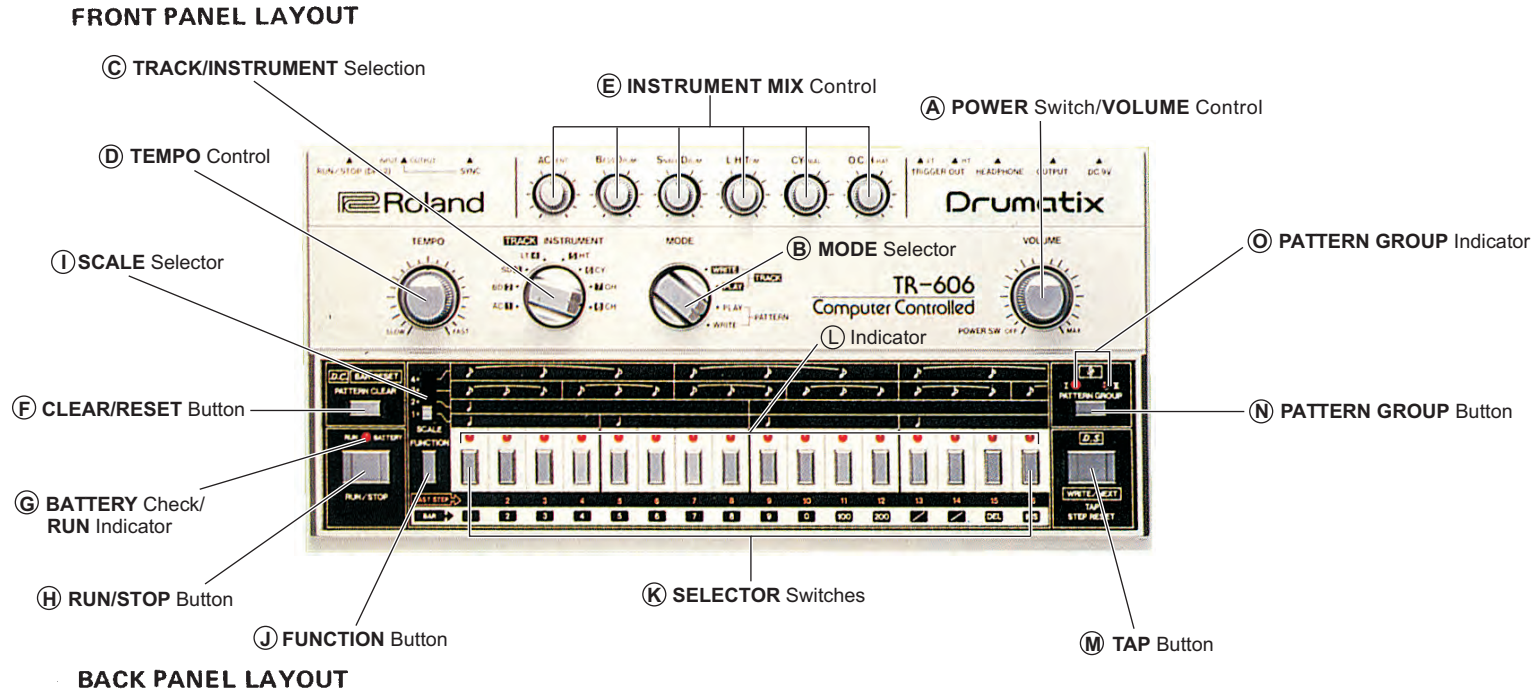

BASIC COURSE (Cont'd)

Writing Rhythm Patterns

We will write a 4/4 Rock Rhythm Pattern (shown in Fig. 1) into the computer memory location chosen by SELECTOR switch (K) #1.

Fig. 1

Step No	1	2	3	4	5	6	7	8	9	10	11	12	13	14	15	16
BD	•							•								•
SD					•											
OH																
CH	•	•	•	•	•	•	•	•	•	•	•	•	•	•	•	•
AC	•	•	•	•	•	•	•	•	•	•	•	•	•	•	•	•

PROCEDURE

1. Connect either headphones or an amplifier to the TR-606, (see BASIC CONNECTIONS).
2. Turn the POWER switch (A) on. (Clockwise).

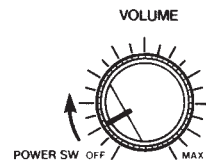

3. Turn the TEMPO control (D) and INSTRUMENT MIX controls (E) to the mid point.

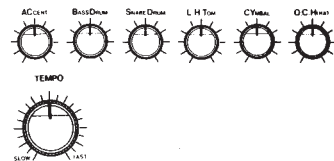

4. Set the MODE selector (B) to PATTERN WRITE position.

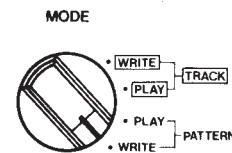

5. Press the PATTERN GROUP button (N) to select Pattern Group I.
 - * The PATTERN GROUP button (N) switches alternately between I and II and illuminates the selected indicator.



6. Press the #1 SELECTOR switch (K), which is the location where we will write the first Rhythm Pattern.

* The selected indicator (#1) should be flashing.



7. While holding the #1 SELECTOR switch (K) down, press the CLEAR/RESET button (F).

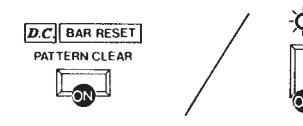

8. Press the RUN/STOP button (H).
 - * The RUN/BATTERY LED (G) lights up and the other LED INDICATORS (L) begin scanning across from #1 to #16, step by step.

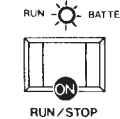

9. Set the SCALE selector (I) to #1, then press the FUNCTION button (J).
 - * When the FUNCTION button (J) is held down, the TR-606 displays the position of every quarter note on the LED indicators (L).
 - * If you make a mistake, or wish to change the SCALE, simply repeat operation 9. (Refer to the ADVANCED COURSE MANUAL for details).

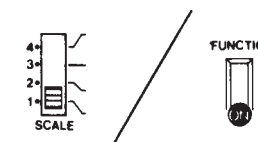

BASIC COURSE (Cont'd)

10. While holding the FUNCTION button (J) down, press the SELECTOR switch (K) of the last step in the measure. In this case, press #16.

** The LED indicators (L) begin scanning across from #1 to the last step that is #16 in this case. Once again, if you make a mistake, just repeat operation 10.*

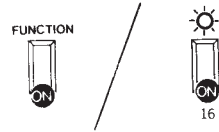

11. Select the instrument to be written by rotating the TRACK/INSTRUMENT selector (C). Set it at BD (Bass Drum) in this case.

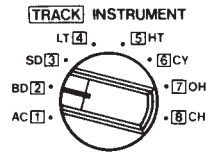

12. Press the SELECTOR switches (K) corresponding to the dots in the score (Fig. 1) one by one.

** The LED indicators (L) of the selected steps will light, and you will hear the selected instrument sound on those steps.*

** You can adjust the speed by using the TEMPO control knob (D). This will allow you to write at a slower speed, if a faster speed proves difficult, etc.*

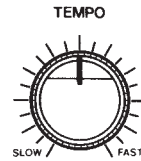

** If you press the wrong SELECTOR switch (K), just press the same SELECTOR switch (K) again, and then the written sound will be erased and the LED indicator (L) will be turned off.*



13. Repeat 11–12 for the other instruments in the Fig. 1 example.

** BD Bass Drum
SD Snare Drum
LT Low Tom
HT High Tom
CY Cymbal
OH Open Hi-Hat
CH Closed Hi-Hat
AC ACcent*

** If you want to erase a note, simply press the respective SELECTOR switch (K). When you want to erase all of the notes of the selected instrument, hold the CLEAR/RESET button (F) down until all the notes are cleared. (Ex. BD in this case)*

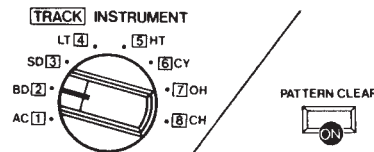

** Erasing is completed when all the LED indicator (L) lights are out.*

14. The pattern can also be written in real time by using the TAP method (M). While the Rhythm is running, just press the TAP button (M) at the appropriate places in the measure.



15. Press the RUN/STOP button (H).



** You have just written the Rhythm Pattern indicated in Fig. 1 into the computer memory.*

IMPORTANT NOTES

When pressing the button, do not fail to release it once, and go on to the next operation, except for the cases that it is specifically instructed to keep pressing the button. (The TR-606 does not function properly if you go on to the next operation without releasing the button.)

BASIC COURSE (Cont'd)

16. Now, write the Rhythm Patterns in Fig. 2 into the assigned memory locations by repeating the procedures from 6 to 15.

● Hi-Hat

}		= CLOSE
		= OPEN
		= CLOSE
		= OPEN

NOTE:
* If you write OH upon CH, CH will gain Accent.

Fig. 2 Assignments of Rhythm Patterns

★ POSITION → PATTERN GROUP I-1

CH		<table border="0"> <tr> <td>[Step No] →</td> <td>1</td><td>2</td><td>3</td><td>4</td><td>5</td><td>6</td><td>7</td><td>8</td><td>9</td><td>10</td><td>11</td><td>12</td><td>13</td><td>14</td><td>15</td><td>16</td> </tr> <tr> <td>BD</td> <td>●</td><td></td><td></td><td></td><td></td><td></td><td></td><td></td><td></td><td></td><td></td><td></td><td></td><td></td><td></td><td></td> </tr> <tr> <td>SD</td> <td></td><td></td><td></td><td></td><td>●</td><td></td><td></td><td></td><td></td><td></td><td></td><td></td><td></td><td></td><td></td><td></td> </tr> <tr> <td>OH</td> <td></td><td></td><td>●</td><td></td><td></td><td></td><td>●</td><td></td><td></td><td></td><td>●</td><td></td><td></td><td></td><td></td><td></td> </tr> <tr> <td>CH</td> <td>●</td><td>●</td><td>●</td><td>●</td><td>●</td><td>●</td><td>●</td><td>●</td><td>●</td><td>●</td><td>●</td><td>●</td><td>●</td><td>●</td><td>●</td><td>●</td> </tr> <tr> <td>AC</td> <td>●</td><td>●</td><td>●</td><td>●</td><td>●</td><td>●</td><td>●</td><td>●</td><td>●</td><td>●</td><td>●</td><td>●</td><td>●</td><td>●</td><td>●</td><td>●</td> </tr> </table>	[Step No] →	1	2	3	4	5	6	7	8	9	10	11	12	13	14	15	16	BD	●																SD					●												OH			●				●				●						CH	●	●	●	●	●	●	●	●	●	●	●	●	●	●	●	●	AC	●	●	●	●	●	●	●	●	●	●	●	●	●	●	●	●
[Step No] →	1		2	3	4	5	6	7	8	9	10	11	12	13	14	15	16																																																																																							
BD	●																																																																																																							
SD						●																																																																																																		
OH				●				●				●																																																																																												
CH	●		●	●	●	●	●	●	●	●	●	●	●	●	●	●	●																																																																																							
AC	●	●	●	●	●	●	●	●	●	●	●	●	●	●	●	●																																																																																								
OH																																																																																																								
SD																																																																																																								
BD																																																																																																								

★ POSITION → PATTERN GROUP I-2

CH		<table border="0"> <tr> <td>[Step No] →</td> <td>1</td><td>2</td><td>3</td><td>4</td><td>5</td><td>6</td><td>7</td><td>8</td><td>9</td><td>10</td><td>11</td><td>12</td><td>13</td><td>14</td><td>15</td><td>16</td> </tr> <tr> <td>BD</td> <td>●</td><td></td><td></td><td></td><td></td><td></td><td></td><td></td><td></td><td></td><td></td><td></td><td></td><td></td><td></td><td></td> </tr> <tr> <td>SD</td> <td></td><td></td><td></td><td></td><td>●</td><td></td><td></td><td></td><td></td><td></td><td></td><td></td><td></td><td></td><td></td><td></td> </tr> <tr> <td>LT</td> <td></td><td></td><td></td><td></td><td></td><td></td><td></td><td></td><td></td><td></td><td></td><td></td><td></td><td></td><td></td><td></td> </tr> <tr> <td>HT</td> <td></td><td></td><td></td><td></td><td></td><td></td><td></td><td></td><td></td><td>●</td><td>●</td><td>●</td><td></td><td></td><td></td><td></td> </tr> <tr> <td>OH</td> <td></td><td></td><td>●</td><td></td><td></td><td></td><td>●</td><td></td><td></td><td></td><td></td><td>●</td><td></td><td></td><td></td><td></td> </tr> <tr> <td>CH</td> <td>●</td><td>●</td><td>●</td><td>●</td><td>●</td><td>●</td><td>●</td><td>●</td><td>●</td><td>●</td><td>●</td><td>●</td><td>●</td><td>●</td><td>●</td><td>●</td> </tr> <tr> <td>AC</td> <td>●</td><td>●</td><td>●</td><td>●</td><td>●</td><td>●</td><td>●</td><td>●</td><td>●</td><td>●</td><td>●</td><td>●</td><td>●</td><td>●</td><td>●</td><td>●</td> </tr> </table>	[Step No] →	1	2	3	4	5	6	7	8	9	10	11	12	13	14	15	16	BD	●																SD					●												LT																	HT										●	●	●					OH			●				●					●					CH	●	●	●	●	●	●	●	●	●	●	●	●	●	●	●	●	AC	●	●	●	●	●	●	●	●	●	●	●	●	●	●	●	●
[Step No] →	1		2	3	4	5	6	7	8	9	10	11	12	13	14	15	16																																																																																																																									
BD	●																																																																																																																																									
SD						●																																																																																																																																				
LT																																																																																																																																										
HT											●	●	●																																																																																																																													
OH				●				●					●																																																																																																																													
CH	●		●	●	●	●	●	●	●	●	●	●	●	●	●	●	●																																																																																																																									
AC	●		●	●	●	●	●	●	●	●	●	●	●	●	●	●	●																																																																																																																									
OH																																																																																																																																										
HT																																																																																																																																										
LT																																																																																																																																										
SD																																																																																																																																										
BD																																																																																																																																										

★ POSITION → PATTERN GROUP I-3

Musical notation for Pattern Group I-3. It consists of six staves labeled CH, OH, CY, HT, LT, SD, and BD. The notation includes various rhythmic patterns and accents.

Step No.	1	2	3	4	5	6	7	8	9	10	11	12	13	14	15	16
BD	●							●	●							
SD				●			●		●			●				
LT																●
HT													●			
CY	●															
OH			●	●				●	●			●	●	●		
CH	●	●	●	●	●	●	●	●	●	●	●	●	●	●	●	●
AC	●	●	●	●	●	●	●	●	●	●	●	●	●	●	●	●

★ POSITION → PATTERN GROUP I-4

Musical notation for Pattern Group I-4. It consists of six staves labeled CH, OH, CY, LT, SD, and BD. The notation includes various rhythmic patterns and accents.

Step No.	1	2	3	4	5	6	7	8	9	10	11	12	13	14	15	16
BD	●					●			●			●		●	●	●
SD				●					●			●		●	●	●
LT								●								
CY									●			●			●	
OH		●			●											
CH	●	●	●	●	●	●	●	●	●	●	●	●	●	●	●	●
AC	●	●	●	●	●	●	●	●	●	●	●	●	●	●	●	●

★ POSITION → PATTERN GROUP I-5

Musical notation for Pattern Group I-5. It consists of six staves labeled CH, OH, CY, SD, and BD. The notation includes various rhythmic patterns and accents.

Step No.	1	2	3	4	5	6	7	8	9	10	11	12	13	14	15	16
BD	●								●	●		●		●		
SD					●								●			
CY	●															
OH			●					●				●		●		
CH	●	●	●	●	●	●	●	●	●	●	●	●	●	●	●	●
AC	●	●	●	●	●	●	●	●	●	●	●	●	●	●	●	●

★ POSITION → PATTERN GROUP I-6

★ POSITION → PATTERN GROUP I-7

★ POSITION → PATTERN GROUP I-8

★ POSITION → PATTERN GROUP I-9

Step No → 1 2 3 4 5 6 7 8 9 10 11 12 13 14 15 16

BD	•			•												
SD					•											
LT																
HT																
CY																
OH																
CH	•	•	•	•	•	•	•	•	•	•	•	•	•	•	•	•
AC	▲			▲				▲				▲				▲

★ POSITION → PATTERN GROUP I-10

Step No → 1 2 3 4 5 6 7 8 9 10 11 12 13 14 15 16

BD	•			•												
SD	•															
LT																
HT																
CY																
OH																
CH	•	•	•	•	•	•	•	•	•	•	•	•	•	•	•	•
AC	▲			▲				▲				▲				▲

BASIC COURSE (Cont'd)

Playing Rhythm Patterns

We have just programmed ten Rhythm Patterns. We will now play these Rhythm Patterns and show some new functions.

PROCEDURE

1. Set the rhythm to stop position by pressing RUN/STOP (H).



2. Set the MODE selector (B) to PATTERN PLAY.

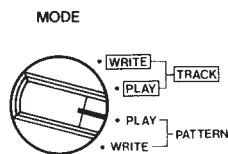

3. Select Pattern Group I (N).



4. Select a Rhythm Pattern by pressing the SELECTOR switch (K) (press #1 in this case).



5. Press the RUN/STOP button (H) to start the rhythm running.



6. Press another SELECTOR switch (K), (press #2 in this case).
* At the end of the first Rhythm Pattern, the #2 Rhythm will begin to play and will repeat.
7. Press the SELECTOR switches (K) #2 and #4 simultaneously.

* The LED indicators (L) #2, #3, and #4 will light up, and the rhythms will play in sequence from #2 to #3 to #4 and then back to #2 again.

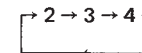

* This is called CHAINING THE RHYTHM PATTERNS. Rhythms can be chained up to four rhythms in a block. The TR-606 has four blocks, #1-4, 5-8, 9-12, and 13-16.

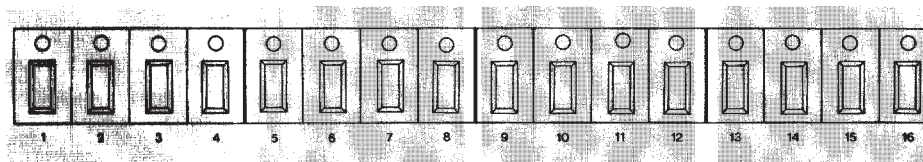

BLOCK I

BLOCK II

BLOCK III

BLOCK IV

NOTE:

* The TR-606 can only chain rhythms within the blocks illustrated above, it cannot for example, chain from #3 to #6.

8. Press the SELECTOR switch (K) #1 again.
* The rhythm returns to #1 rhythm at the end of the #4 rhythm and repeats rhythm #1.
9. Press the RUN/STOP button (H) to stop the rhythm.

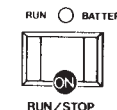

BASIC COURSE (Cont'd)

Composing the Rhythm Track

We have programmed ten Rhythm Patterns shown in Fig. 2 into the memory locations #1 – #10. Through the use of these rhythms, we will now compose an entire composition in Track #1 according to the following composition table.

Fig. 3 Track Composition Table

I-1	%	%	I-2
I-5	I-6	I-7	I-8
I-9	I-3	I-9	I-4
I-9	I-3	I-9	I-10

PROCEDURE

1. Stop the rhythm.
2. Set the MODE selector (B) to TRACK/WRITE.

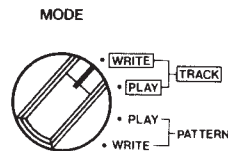

3. Set the TRACK/INSTRUMENT selector (C) to Track #1.

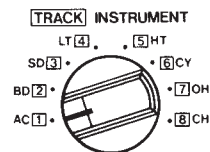

4. Press the CLEAR/RESET (F) button.



** This button re-sets the first bar of the Track.*

5. Select in PATTERN GROUP I (G).



6. Start the rhythm by pressing RUN/STOP (H).

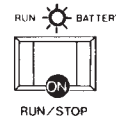

** The rhythm previously recorded in the 1st bar of the Track will be heard.*

7. Choose a new 1st bar Rhythm Pattern by pressing a SELECTOR switch (K), in this case #1.

** The new Rhythm Pattern will play at the end of the old rhythm, and will repeat.*



8. Press the TAP button (M).



** The running Rhythm Pattern will be recorded in the Track Memory as the 1st bar, and the Track Memory is advanced to the 2nd bar, and it will play the previously recorded old rhythm.*

You can re-select a new 2nd bar Rhythm Pattern and then press the TAP button (M) to record it in Track Memory. (Repeat the PROCEDURES 7 & 8 for bars following the 2nd bar within a block. 4 patterns can be written at once between the 5th and 8th bar by following method given in CHAINING THE RHYTHM PATTERNS, see page 11.)

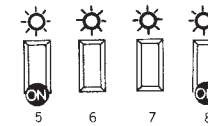

9. Continue switching Rhythm Patterns and logging them into Memory by pressing the TAP button (M).

Repeat the PROCEDURES 7 & 8 for writing from the 9th bar to the one before the last bar.



10. At the last bar, where the SELECTOR switch #10 is pressed in this case, choose a rhythm and then press the CLEAR/RESET button (F).



BASIC COURSE (Cont'd)

** By pressing the CLEAR/RESET button (F), you have set the last rhythm as the D.C. bar. The D.C. bar is the last bar in the composition, and after playing the D.C. bar, the Track will return to the first bar of the Track and play the entire Track again from the beginning (1st bar).*

- Press the TAP button (M) to write the rhythm as the D.C. bar in the Track Memory.



- Stop the rhythm. (Press the RUN/STOP button)

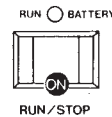

Now you have programmed the entire composition shown in Fig. 3, into Track #1.

The program can be checked and corrected from the beginning of the Track by the following procedure:

- Stop the rhythm.

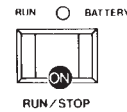

- Set the MODE selector (B) to TRACK WRITE.

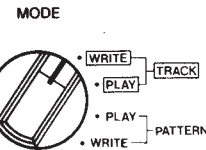

- Press the CLEAR/RESET button (F) to re-set the Track to the 1st bar.



- Start the rhythm.

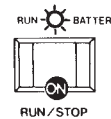

Check the Rhythm LED indicators (L) which display the Rhythm Pattern numbers.

- If the rhythm number is wrong, press the SELECTOR switch (K) to rewrite the correct Rhythm Pattern, and then press the TAP button (M) to write it into Memory.

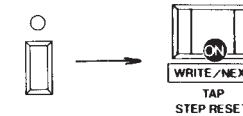

If it is all right, just press the TAP button (M) to advance to the next bar.

- Repeat step 5 until you reach the last bar (D.C. bar).
- Stop the rhythm.

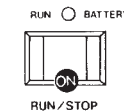

A composition of up to 64 bars in a Track can be programmed. The TR-606 has 8 Tracks. Refer to the ADVANCED COURSE MANUAL for details.

Playing the Rhythm Track

- Stop the rhythm.
- Set the MODE selector (B) to TRACK PLAY.

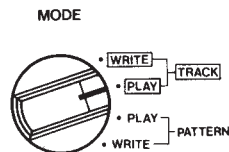

- Set the TRACK/INSTRUMENT selector (C) to #1.

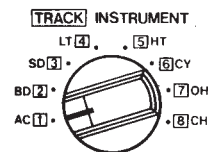

** The PATTERN GROUP will be selected automatically.*

- Press the CLEAR/RESET button (F) to re-set the Track to the 1st bar.



- Start the rhythm.

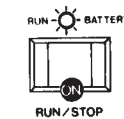

** The rhythm will run and return to the 1st bar of the Track at the end of the D.C. bar. This will be continuously repeated.*

ADVANCED COURSE

Control Descriptions FRONT PANEL LAYOUT

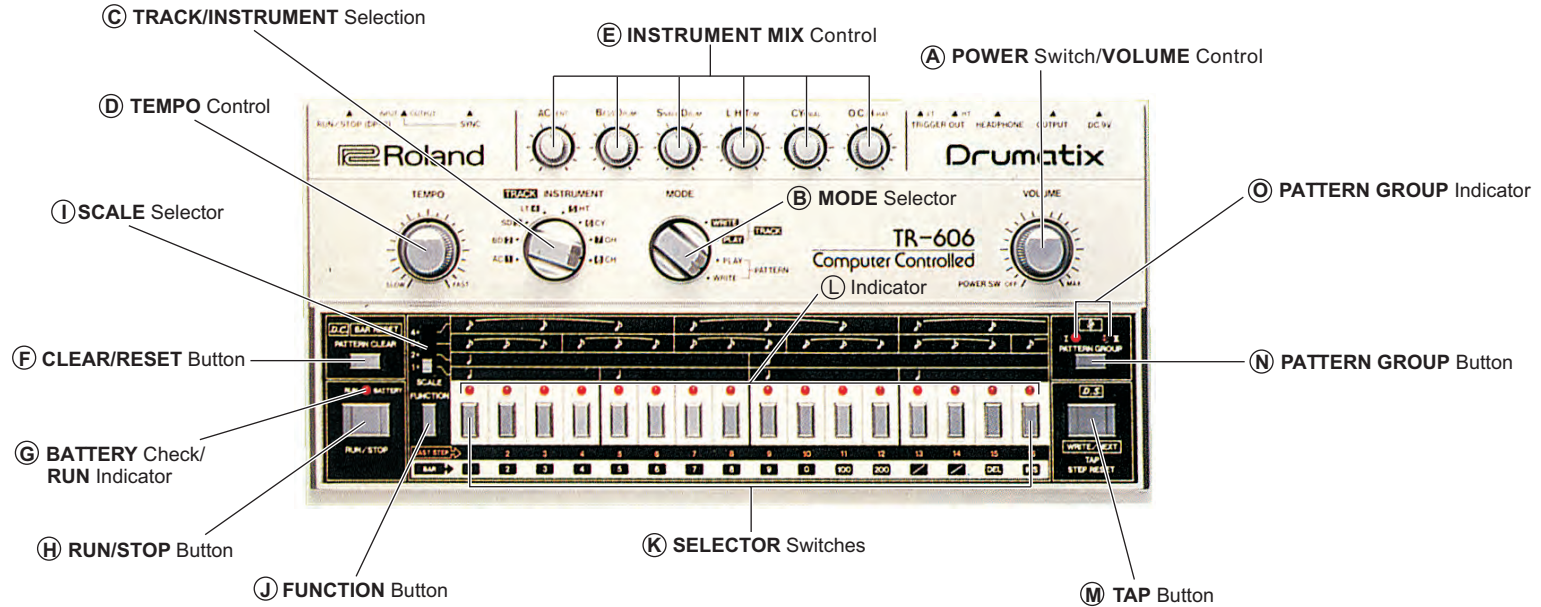

BACK PANEL LAYOUT

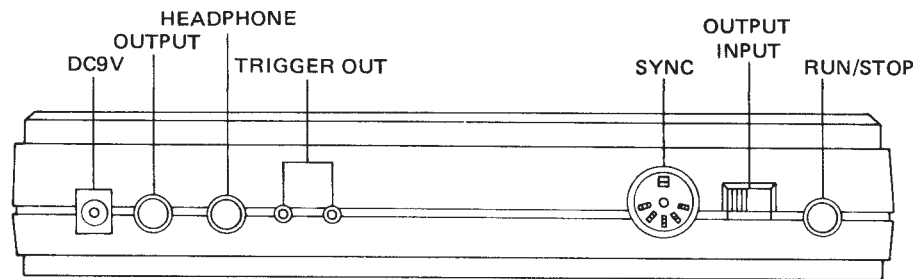

ADVANCED COURSE

Control Descriptions

E INSTRUMENT MIX Controls

These controls, located at the top center of the control panel, are used to achieve a balanced mix between the various instrument voices available with the TR-606.

D TEMPO Control

This rotary pot is used to control the Tempo of the TR-606's rhythms. Tempo is not a programmable function and may be varied during the writing or playing of Rhythms or Tracks for maximum control and flexibility.

C TRACK/INSTRUMENT Selector

This 8 position selector serves for a dual purpose. During the programming of Rhythm Patterns, it is used to select any one of 7 different instrument voices or Accent programmed.

The second function of the control is as a selector for the 8 memories used in composing Rhythm Tracks. Each one of the Memories 1 to 7 contains storage capacity for 64 bars of a Rhythm Track, while memory 8 has a storage capacity for 256 bars of a Rhythm Track. Each of these memories may be accessed individually for programming or playback. Up to four tracks may be chained together for composing Tracks of extended length, with a maximum track length of 256 bars.

B MODE Selector

This rotary control is used to select one of the four basic operation modes of the TR-606:

PATTERN WRITE Mode allows you to program the available Rhythm Patterns (16 each in Pattern Groups **N** I and II) to be programmed with any desired rhythm for each of seven available instruments plus Accent.

PATTERN PLAY Mode allows performance of the 32 available Rhythm Patterns you have programmed. Rhythm Pattern selections are

made using the 16 Selector Switches **K** and the Pattern Group **N** Selector. Within certain guidelines, adjacent Rhythm Patterns may be chained together to perform as single, or more complex Rhythm Patterns.

TRACK PLAY Mode allows the performance of an entire Rhythm Track composition programmed into one or more of the 8 **TRACK** Selector positions.

TRACK WRITE Mode allows any of the 16 Rhythm Patterns programmed into Pattern Group I **N** (or the 16 Pattern Group II rhythms) to be combined into compositions (Tracks) and programmed into any one or more consecutive memories selected by the Track Selector.

A POWER SWITCH/VOLUME Control

The master **VOLUME** Control **A** also serves as the power On/off Switch, cutting off all D.C. power to the TR-606 when rotated fully counterclockwise. For the TR-606 to perform any function, this switch must be rotated clockwise past its initial detent. The 'On' status of the TR-606 may be checked using the various LED indicators **L** on the front panel. Once the **POWER SWITCH/VOLUME** Control **A** is past its initial detent, it will control the overall output level present at the Output and Headphone output jacks for amplification and monitoring.

F CLEAR/RESET Button

Depending on the **MODE** Selector **B** position and the **RUN/STOP** condition, this button will perform the following functions:

When stopped in the **PATTERN WRITE** Mode, this button will clear an entire rhythm pattern by pressing it while holding the **SELECTOR** Switch **K** down for the Rhythm Pattern to be cleared. The Scale and number of Steps in the Rhythm Pattern will not change.

When running in the **PATTERN PLAY** Mode, this button has no effect.

When stopped in the **TRACK PLAY** Mode or **TRACK WRITE** Mode, this button Resets the TR-606 so that it will begin with bar 1 of the Track selected when the **RUN** button **H** is pressed. If this button is pressed while the **FUNCTION** button **J** is held down, the D.C. bar will be displayed using the LED indicators **L**.

When running in the **TRACK PLAY** Mode, this button has no effect.

When running in the **TRACK WRITE** Mode, this button writes the current bar into memory as a D.C. bar, signalling the end of the track.

G BATTERY CHECK/RUN Indicator

This LED will light to indicate the Run condition. If the indicator flashes or does not illuminate in the Run condition even if the other LEDs still illuminate, replace all of the batteries with new ones.

H RUN/STOP Button

This button alternately starts and stops the running of rhythms and will perform differently according to the position of **MODE** Selector **B**.

I SCALE Selector

This selector determines the number of steps assigned to each quarter note beat, as shown by the relationship between the graphic illustration to the right of the **SCALE** Selector **I** and the 16 **SELECTOR** Switches **K** below. The position of the **SCALE** Selector **I** is memorized into computer memory when the **FUNCTION** button **J** is pressed while running in the **PATTERN WRITE** Mode.

J FUNCTION Button

This button will perform different functions according to the **RUN/STOP** condition and the **MODE** Selector **B** position.

When stopped in the **PATTERN WRITE** Mode, this button has no effect.

When running in the **PATTERN WRITE** Mode, pressing the **FUNCTION** button **J** will memorize the **SCALE** Selector **I** position and virtually display the first step of each quarter note beat using the 16 LED indicators **L** and allows you to set the last step by pressing the **SELECTOR** Switch **K**.

In the **TRACK PLAY** and **TRACK WRITE MODE**, pressing the **FUNCTION** button **J** will display the current bar number within the Track using the LED indicators **L**. While the **FUNCTION** button **J** is being held down, the **SELECTOR** Switches **K** and their associated LED indicators **L** may be used to change the current bar number. Finally, while the rhythm is stopped, hold the **FUNCTION** button **J** down while pressing either the **CLEAR/RESET** **F** or **PATTERN GROUP** **N** to display the bar number of the D.C. or D.S. sign, respectively using the LED indicators **L**.

When running in the **TRACK PLAY** and **TRACK WRITE MODE**, pressing the **FUNCTION** button **J** will display the current bar running using the LED indicators **L**.

L LED Indicators

The 16 LED Indicators **L** located directly above the **SELECTOR** Switches **K** are used to indicate the Rhythm Pattern number, Steps within a Rhythm Pattern, or Bar Numbers, depending on the use of the other TR-606 controls. Details of these different applications and reading Bar numbers are given in the Operation section of this manual.

K SELECTOR Switches

These 16 switches will perform different functions according to the **RUN/STOP** condition and the **MODE** Selector position.

When stopped in the **PATTERN WRITE** and **PATTERN PLAY** Mode, the **SELECTOR** Switches **K** determine whether individual Rhythm Pattern or Chained Rhythm Pattern will begin when the **RUN/STOP** button **H** is pressed. A maximum of four adjacent Rhythm Patterns within the blocks of 1–4, 5–8, 9–12, and 13–16 may be chained together to perform as one complex Rhythm Pattern and may be played once or repeated as a single unit. When running in the **PATTERN WRITE** Mode, the **SELECTOR** Switches **K** are used to write the instrument selected with the **TRACK/INSTRUMENT** selector **C** into specific steps of the Rhythm Pattern. Details of this procedure are given in the Operation section of this manual.

When stopped in the **TRACK PLAY** and **TRACK WRITE MODE**, holding the **FUNCTION** button **J** down allows the **SELECTOR** Switches **K** to be used to select any specific bar number within that track.

When running in the **TRACK WRITE** Mode, the **SELECTOR** Switches **K** may be used to select individual Rhythm Patterns or to designate Chains of Rhythm Patterns. Note: The Rhythm Patterns heard here are not written into the Track memory until the **TAP** switch **M** is used.

N PATTERN GROUP Button

Depending on the **MODE** Selector **B** position and the **RUN/STOP** condition, this button will perform the following functions:

When stopped in the **PATTERN WRITE** and **PATTERN PLAY MODE**, and when stopped in the **TRACK WRITE** Mode the **PATTERN**

GROUP button **N** switches the TR-606's memories between the 16 Rhythm Patterns in **PATTERN GROUP** **N I** and the 16 Rhythm Patterns in **PATTERN GROUP** **N II**.

When stopped in the **TRACK PLAY** Mode, the Pattern Group number which has been to program the Track in the **PATTERN WRITE** Mode will be selected automatically. The **PATTERN GROUP** button **N** itself will have no effect.

When stopped in the **TRACK WRITE** or **TRACK PLAY**, hold the **PATTERN GROUP** button **N** down while pressing the **FUNCTION** button **J**, and the LED indicators **L** will display the bar number to which the **.S.** sign has been assigned.

When stopped in the **TRACK WRITE** Mode, the **PATTERN GROUP** button **N** selects the **PATTERN GROUP** to be written into that Track Memory.

When running in the **TRACK WRITE** Mode, the **PATTERN GROUP** button **N** will assign the current bar as the **.S.** sign bar in the Track memory.

M TAP Button

Depending on the **MODE** Selector **B** position and the **RUN/STOP** condition, this button will perform the following functions:

When running in the **PATTERN WRITE** Mode, this button will perform the real time Tap programming.

When running in the **PATTERN PLAY** Mode, the **TAP** button **M** acts as a **STEP RESET** button **M** to cause the Running Rhythm Pattern to immediately begin again from the first Step of the current Rhythm.

When stopped in the **TRACK PLAY** or **TRACK WRITE** Mode, the **TAP** button **M** will advance one bar further into the selected Track.

ADVANCED COURSE (Cont'd)

When running in the **TRACK PLAY** Mode, pressing the Tap button will immediately return the Track being played to the measure that has been assigned the \mathcal{S} sign and continue normally from that point.

When running in the **TRACK WRITE** Mode, the Tap button will perform a **WRITE/NEXT** function (M), writing the Rhythm Pattern currently being heard and indicated on the LED Indicators (L) into the Track memory and advancing the Bar number assignment accordingly.

This **WRITE/NEXT** function (M) always deals in complete Rhythm Pattern units. If a Chained Rhythm Pattern is written into a Track using the **TAP** button (M), the Bar number will advance the number of bars contained within the Chained Rhythm Pattern.

Other Connections

Connection Cords

The TR-606 is provided with a low noise connection cord terminating in a ¼ inch phone jack for connection with the Drumatix output at one end and with an RCA connection with an adapter to a ¼ inch phone jack for amplification connection at the other end. The ¼ inch phone jack adapter will be used for most of amplification connections.

The RCA jack offers access to most component hi-fi systems, a significant advantage when the TR-606 is used for practice or composition at home without the inconvenience of transporting and setting up stage amplification. Connect the TR-606 output with an Aux. or Tape input, avoiding the Phono inputs with their special internal equalization. The TR-606 will appear at one speaker only unless a 'Y' cable or junction box such as the BOSS J-5 is used, or unless your hi-fi has a master Mono/Stereo selector. Important Note: Begin with the volume level on your TR-606 set at Zero and the hi-fi at normal or lower than normal levels. By gradually raising the TR-606 level and using caution as different programs and instrument levels are selected you can easily avoid high level signals that might otherwise damage sensitive hi-fi equipment.

The RCA jack also offers instant access to many multi-track recorders and consoles, a distinct advantage considering the unique functional abilities of the TR-606 Drumatix.

TRIGGER OUTPUTS

The TR-606 Rhythm Composer provides two independent, programmable **TRIGGER OUTPUT** to allow interfacing with synthesizers or sequencers. Each trigger signal is a positive 15 Volt, 20 millisecond pulse suitable for activating either the Trigger or Gate inputs of the most major brands of equipment.

A synthesizer such as the Roland SH-09 may be gated to process its own oscillators. By combining a mono synthesizer such as the SH-09 with a sequencer such as one of the Roland CSQ digital sequencers, the TR-606 **TRIGGERs** will start and/or step the sequencer/synthesizer combination for programmed musical lines. The **TRIGGERs** may also be used to control the rhythm and rate of the Arpeggio sections of the Roland JUPITER polyphonic synthesizers.

The two **TRIGGER OUTPUT** correspond to rhythms programmed into the Low Tom or High Tom positions, rhythms determined by the Track/Program selector and programming. These instruments may be used simultaneously with their **TRIGGER OUTPUT** or programmed specifically to provide with **TRIGGER OUTPUT** rhythms, silencing the instruments using the individual **INSTRUMENT MIX LEVEL** (E) controls.

Figure 1 illustrates various interfacing applications for the **TRIGGER OUTPUT**.

Pedal Switching

The TR-606 is equipped with a ¼ inch Pedal Switch jack for connection with an optional Roland DP-2 Damper Pedal. This jack provides with a remote control option for the RUN/STOP button without defeating the function of the front panel RUN/STOP button itself.

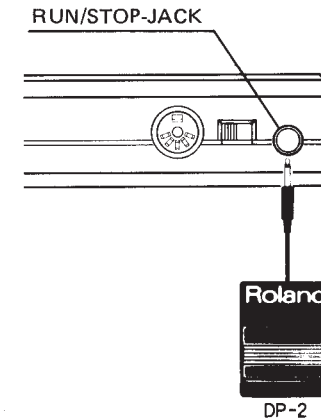
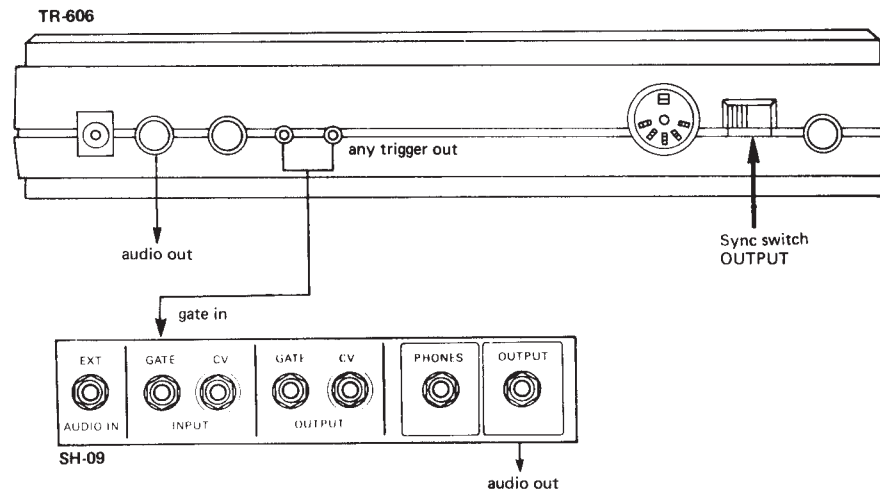
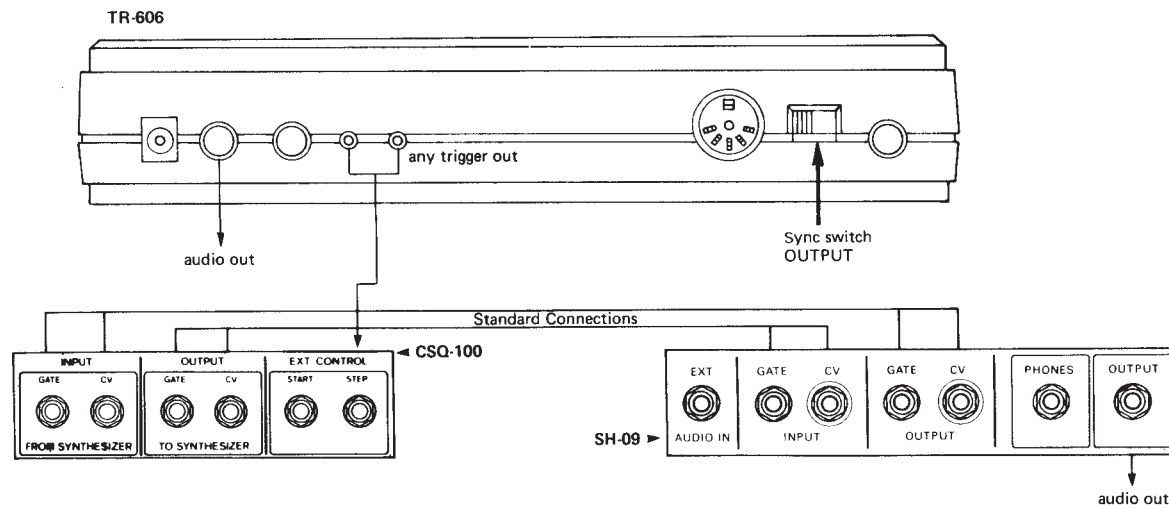

Fig. 1
TR-606 + SH-09



TR-606 + CSQ-100 + SH-09



TR-606 + CSQ-600 + SH-2

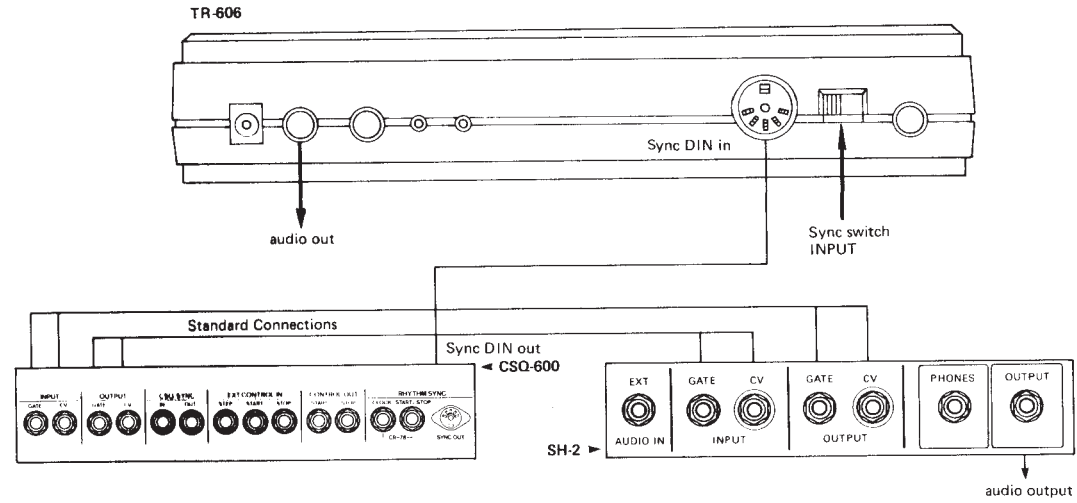

TR-606 + JP-4

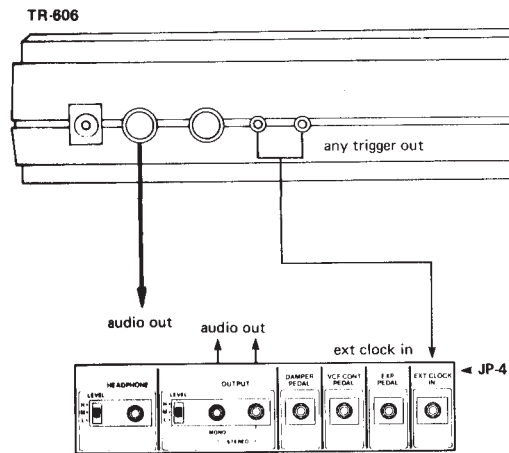

TR-606 + JP-8

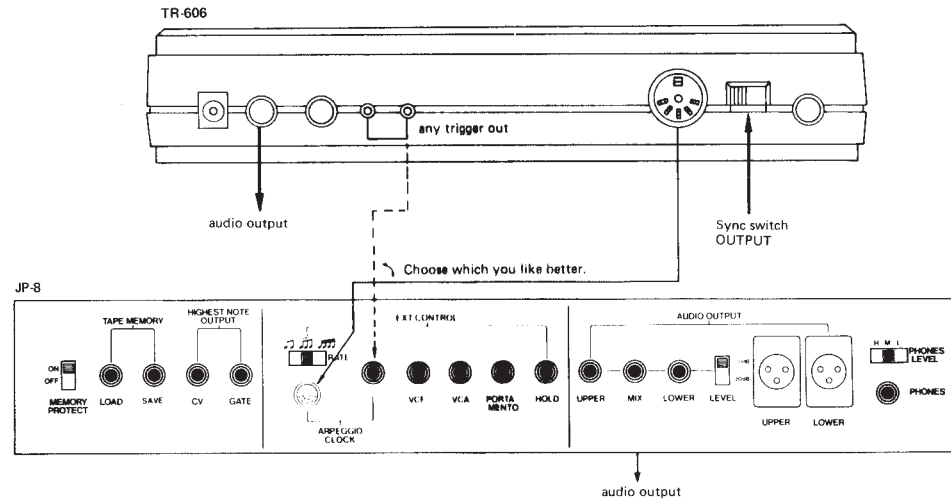

TR-606 + MC-4 + SYSTEM-100M

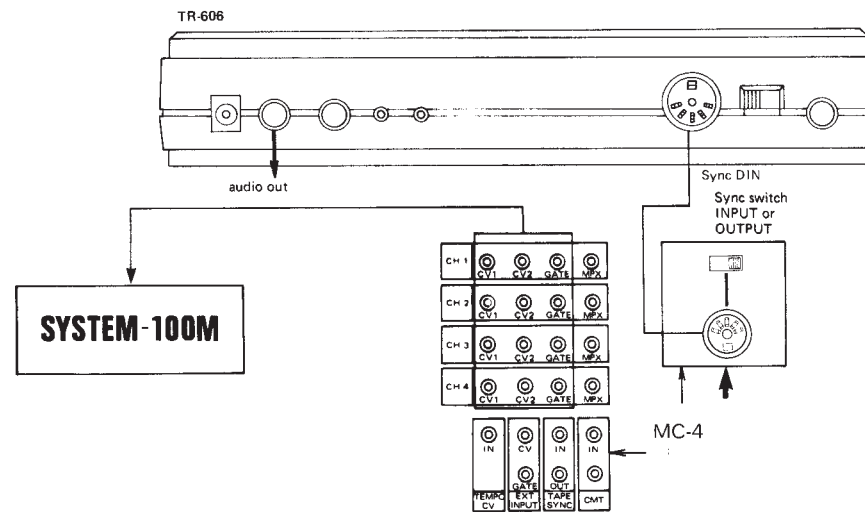

SYNC INPUT/OUTPUT

The **SYNC** switch on the TR-606 allows it to be synchronized perfectly with units such as the Roland CSQ-600 Digital Sequencer, allowing total rhythmic freedom of each unit while remaining in perfect tempo with one another. This interfacing uses the exclusive Roland standard interface connection.

The TR-606 may also be synchronized to the Arpeggio section of the Roland Jupiter-8 polyphonic synthesizer.

To Sync two units, connect a five pin DIN cord with the **SYNC** jack of each unit and move the TR-606 **SYNC** switch to the **INPUT** position for connection with the CSQ-600, or to the **OUTPUT** position for connection with the Jupiter-8. Remember that the **SYNC** switch

must be in the **OUTPUT** position so that the TR-606 will operate by itself.

The TR-606 may also be synchronized to the Roland MC-4 polyphonic sequencer, using either the TR-606 or the MC-4 to control the other unit. For more details refer to the MC-4 owners manual.

Refer to Figure 1 for several specific applications of **SYNC** connections.

Battery Eliminator

The TR-606 is fully portable, normally relying on batteries for all internal functions and to power the self-contained **HEADPHONE** amplifier. To extend battery life, merely connect a BOSS ACA Battery Eliminator in this socket. "CAUTION" Don't connect any other brand

of Battery Eliminators as this could damage the internal circuitry of the TR-606.

Memory Back-Up

The TR-606 Rhythm Composer features a non-volatile memory which will retain Rhythm Patterns and Track compositions when switched **'OFF'** and disconnected from any external power source. The TR-606 relies on its batteries as a back-up circuit to protect these memories. Always replace the TR-606's batteries with a complete set of new batteries when the **RUN/BATTERY** Indicator (Ⓞ) LED either flashes or fails to illuminate during the normal **RUN** condition of the TR-606. If you change the batteries as quickly as within one minute, the memory can hold the DATA.

Playing Rhythm Patterns

The series of sixteen **SELECTOR** Switches (Ⓚ) at the bottom of the TR-606 panel are used to select which Rhythm Pattern you want to play. Each of these sixteen **SELECTOR** Switches (Ⓚ) has two modes (I & II) which can be different from each other for a total of thirty-two Rhythm Patterns, with each Rhythm lasting for one measure.

After hooking up the TR-606 as previously described in the Basic Connections Section, set the **MODE** Selector (Ⓛ) to the **PATTERN PLAY** position. When this is done, you will notice that the LED on one of the **SELECTOR** Switches (Ⓚ) will begin to flash. This tells you that the flashing of **SELECTOR** Switch (Ⓚ) is the first Rhythm Pattern that will play when you press the **RUN/STOP** button (Ⓜ).

Also lit on the TR-606 Panel is one of the two LEDs above the **PATTERN GROUP** button (Ⓝ). These indicate from which group (I or II) the flashing Rhythm will play. To change from one

group to the other, press the **PATTERN GROUP** button (Ⓝ), and the LED will change from one to the other. **PATTERN GROUP** Selection is available only while the Rhythm is stopped. Press the **RUN/STOP** button (Ⓜ) to start the Rhythm running. Adjust the overall Tempo with the **TEMPO** control (Ⓞ) which is continuous from 40 to 300 beats per minute. While the Rhythm is running, you will notice that the LED indicators (Ⓛ) on the **SELECTOR** Switches (Ⓚ) flash in sequence from the left to the right of the unit. The speed of their sequential motion will correspond to the tempo of the pattern (which is set by the **TEMPO** control).

Press the **RUN/STOP** button (Ⓜ) to stop the Rhythm. When this is done, you will notice that the LED on the Rhythm you had selected will again begin to flash.

Mixing Percussion Sounds

The level of each percussion sounds can be raised or lowered in accordance with your own taste through use of the six **MIX** controls (ⓔ) at the top of the panel. By using these **MIX** controls (ⓔ), it is possible to attain the perfect balance between the instruments for any rhythm.

Switching Rhythm Patterns

It is possible to switch from one Rhythm Pattern to another while the TR-606 Rhythm is running. The TR-606 will always finish the measure, and play until switched to the newly selected Rhythm. By switching between the Rhythms, it is possible to try various Rhythms together to get a feel of switching from a straight beat to a fill or break.

Chaining Rhythm Patterns

You will notice that the sixteen **SELECTOR** Switches (K) have been divided into four Block Groups of four switches each (1-4, 5-8, 9-12, and 13-16). These represent groupings of Rhythm Patterns that can be chained together to run sequentially in a group. This is used for performing a two measure repeating rhythm, (which is very common in Rock Music), for doing 4/4 time using scale 2 or 4, or for doing odd time signatures.

To chain Rhythm patterns together, press two **SELECTOR** Switches (K) such as (2 and 4) within a group simultaneously. This action causes the first switch's LED (2) to flash

while the others (3 & 4) illuminate but do not flash. This LED status indicates that the Rhythms are chained and will play in a sequence. It is possible to chain 2, 3, or 4 Rhythm Patterns together, but they must all be from the same group. You cannot, however, create more than one chain within each four groups.

For now, select the chained Rhythm Pattern 2, 3 and 4. Press **SELECTOR** Switches (K) 2 and 4 simultaneously, and then LED indicators (L) 3 and 4, illuminate while LED 2 flashes. Select one of the two **PATTERN GROUPS** (N) by pressing the **PATTERN GROUP** button (N). Again, the **PATTERN GROUP** selection is available only under Rhythm Stopped condi-

tion. Start the TR-606 by pressing **RUN/STOP** (H) and you will see that the Rhythm runs from 2 to 3 to 4 and then back to 2 again.

Press the **TAP** button (M) while the Rhythm is running. This action causes the running Rhythm to re-start from the first step of the Rhythm immediately. This re-set type of action allows for diverse and creative Pattern changes while a chained Rhythm is running as the Rhythm re-starts from the first step of whatever Rhythm is playing rather than from the beginning of the chain. For example, if you press the **TAP** button (M) while playing the Rhythm Pattern 4 of the chained Rhythm 2, 3, 4, the Rhythm will re-start from the first step of #2 rather than #4.

Writing Rhythm Patterns

As mentioned earlier, your TR-606 will not only play back Rhythms but also allow you to write them as well. Because we are not just writing the Rhythms but are storing them into computer Memory as well, we call this process "Programming". We will now program the Rhythm Score written in Fig. 2.

Stop the Rhythm if it is running, and set the **MODE** Selector (B) to **PATTERN WRITE**. This will cause the LED on the Rhythm Pattern selected to stop flashing. Press **SELECTOR** Switch (K) #1 and set the **PATTERN GROUP** (N) to 1. Clear the Memory in #1 position by pressing the **CLEAR/RESET** (E) button while

holding down the #1 **SELECTOR** Switch (K). When this is done, the **PATTERN GROUP** indicator LED (C) will flash to indicate that the memory in position #1 has been cleared.

The TR-606 programs Rhythms in a Step Sequence process, which breaks each measure (and each beat) down into a series of steps so that the programming can be completely accurate. To Program a Rhythm, you must first select a Scale position which basically determines how many steps there will be for each beat (quarter note). This process will be described in detail later in this section.

Press the **RUN/STOP** (H) sequence, but you will not hear a Rhythm because it has been cleared. While the Rhythm is running, set the **SCALE** selector (I) switch to 1 and press the **FUNCTION** button (J). You have just set up a scale in which the quarter note will consist of four steps (each step corresponding to one sixteenth note). Once the **FUNCTION** button (J) has been pressed, the Scale is memorized for its selected position. While the **FUNCTION** button

Fig. 2 Rhythm Score 1

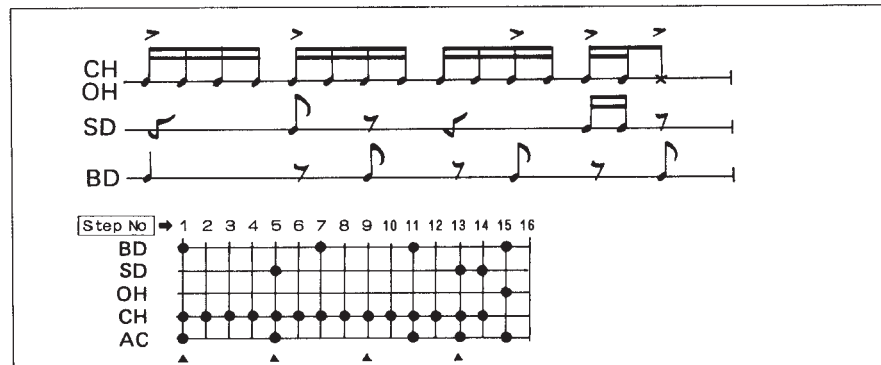

Ⓜ is depressed, you will see the quarter notes (beats) displayed on the row of LEDs. For Scale #1 the LED displays show every fourth LED lit.

It is now necessary to choose the number of steps of which the measure will consist. While holding down the **FUNCTION** button Ⓜ, press the Selector Switch corresponding to the last step of the pattern (which in this case is 16). You have now set up a Rhythm Pattern consisting of sixteen steps, with each beat (quarter note) consisting of four steps.

Step Programming

Choose an instrument sound to be programmed by rotating the **TRACK/INSTRUMENT** selector Ⓢ (located next to the **MODE** selector Ⓟ). It is usually easiest to program a Rhythm starting with the Bass Drum, so rotate the selector to BD. On the Program Score 1, you will see BD is to be played on Steps 1, 7, 11, and 15, so touch the **SELECTOR** Switches Ⓚ that correspond with these Step Numbers described below them.

As is the case with many of the controls on the TR-606, the **SELECTOR** Switches Ⓚ serve a dual function that is both choosing Rhythms to be played and also programming the Rhythm itself. You should now hear the Bass Drum sound on those Steps that you selected. If this is not the case, go back to the beginning of this section and repeat the process. When the Bass Drum is sounding properly, switch the **TRACK/INSTRUMENT** selector Ⓢ to SD, and program the Snare Drum as it indicated on the Program Score 1 at Steps 5, 13, and 14.

Continue programming the other instrument voices indicated on the Program Score. It may be easier for you to program if you adjust the **TEMPO** to a slower speed. If you make a mistake and press the wrong switch, simply press it again and the LED will go out indicat-

ing it has been cancelled.

It is possible to clear all 16 steps of any selected voice by pressing the **CLEAR/RESET** button Ⓣ until all the notes are erased.

This saves time when clearing voices that have been programmed on every step.

TAP Programming

While most of the programming is done using the Step method, it is also possible to program in real time by a Tap method. While the Rhythm just programmed is running, return the **TRACK/INSTRUMENT** selector Ⓢ to SD and cancel the Snare Drum sounds you programmed by pressing the **CLEAR/RESET** button Ⓣ. You can now re-program the Snare Drum simply by pressing the **TAP** button Ⓜ at appropriate places in the measure. Wherever you pressed the **TAP** button Ⓜ, there will automatically be programmed a Snare Drum sound.

If the Tapped Rhythm is out of **SYNC** with the others, it can be erased just the same as when it is programmed in the Step method. Sometimes it may be easier to use the **TAP** Ⓜ method when the Rhythm is running fairly slowly as synchronization is easier.

You have just programmed your first Rhythm into the TR-606. This Rhythm will be stored in memory and can be edited at **PATTERN WRITE** position.

Steps and Programming

With the TR-606, each measure is divided into a certain number of parts which we call **STEPS**. The Rhythm you just programmed used a 16 Step measure, which we played in 4/4 time. Therefore the measure was comprised of four quarter notes, each quarter notes was comprised of four sixteenth notes and each sixteenth note corresponding to one **STEP**. So, for each Step in Program Score 1, each Instrument

Voice had either a beat or a rest. (The rest is added automatically when you do not program a beat in that place.

Fig. 3

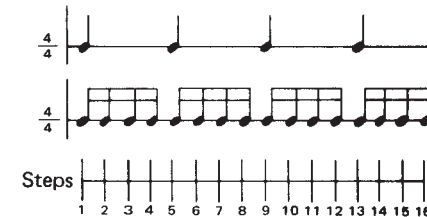

The Program Score is a transcription of the music score using the system that indicates the minimum number of notes and rests. However, it is not completely musically accurate in that a quarter note, for example, when transcribed to the Program Score from a music score, written as a sixteenth note, followed by three rests. This also follows for whole notes, half notes and eight notes as well.

Fig. 4

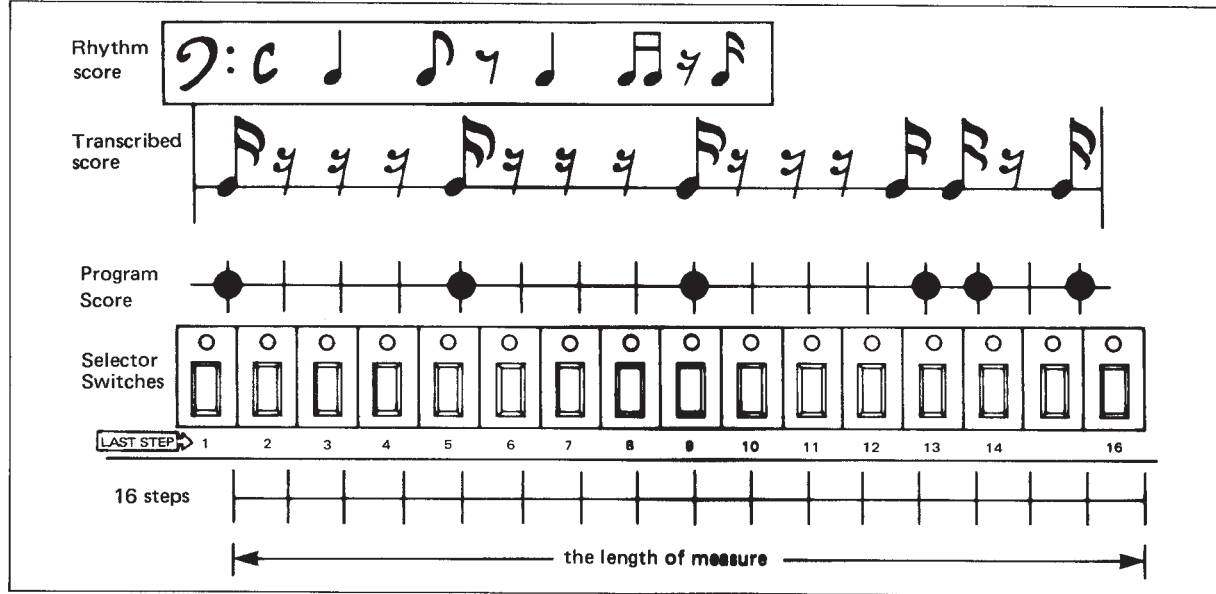

The **SELECTOR SWITCHES** (K) are arranged in the order of sequence for the Rhythm Pattern. This means that in Rhythm Score #1, the #1 switch will indicate the beginning of the measure and #16 equals the end of the measure. When the LED for step 16 lights up, one measure has been played.

Setting the SCALE (I)

The **SCALES** (I) on the panel above the **SELECTOR** Switches (K) indicate the **SCALE** (I) (or number of steps for each beat). Different **SCALES** (I) are chosen for different Rhythms so that all the Rhythms will be in time with each

other when you switch from one Rhythm to another as you did in the **Playing Rhythm Patterns** Section. Some Rhythms you may write may require as small a division as thirty second notes while other Rhythms you write need only sixteenth notes as the smallest division. By choosing the proper **SCALE** (I) for the Rhythm, the Rhythm Patterns will all be able to be played back in time with each other when you make switching between them. The **SCALE** (I) must always be chosen to match the minimum division of the beat to be used in the Rhythm pattern. We will now program a Rhythm in 4/4 time: one that uses a 12 Step measure and the Number 3 Scale.

More details are explained in the last part of this manual (P. 30).

Fig. 5

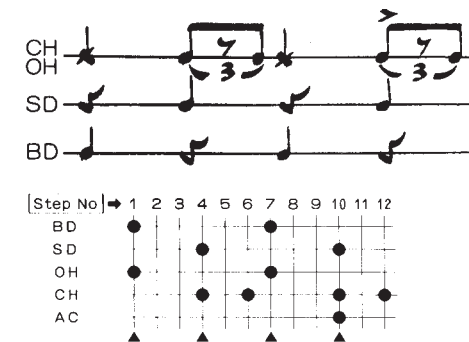

ADVANCED COURSE (Cont'd)

Stop the Rhythm and set the **MODE SELECTOR** (B) to **PATTERN WRITE**. Press **SELECTOR Switch** (K) #1 so we can program in this position. The LED on that switch should light up and flash. Press the **CLEAR/RESET** button (F), erasing the memory. Press the **RUN/STOP** button (H) and set the **SCALE** selector (I) switch to 3. Press the **FUNCTION** button (J) but do not let it up. While holding it down, press the switch for Step #12, and then release the **FUNCTION** button (J). You have just set a 12 Step pattern using a #3 Scale.

With the **TRACK/INSTRUMENT** selector (C), choose the sounds you need to program the Program Score #2 shown in Fig. 6. Program this Rhythm as you had done in Program Score #1. Programming of I and II **PATTERN GROUPS** (N) is done in the same manner, the sole difference being the position of the **PATTERN GROUP** switch (N) during the programming.

Writing Chained Rhythm Patterns

The Chained Rhythm Pattern can be selected in the **PATTERN WRITE MODE** while the Rhythm is stopped. This is done the same as was done in the **PATTERN PLAY** Mode, by simultaneously pressing any two of the **SELECTOR Switches** (K) within a group (1-4, 5-8, 9-12 or 13-16). As we said before, Chained Rhythm Patterns can be used to create Rhythm Patterns of two or more measures in length or to create Rhythm Patterns in odd time signatures.

Chained Rhythm Patterns are also mentioned in CHAINING RHYTHM PATTERNS (See Basic Course)

We will now program the following Rhythm Pattern using two Rhythm Patterns chained together. Stop the Rhythm and set the **MODE** selector (B) to **PATTERN WRITE**. Press **SELECTOR Switches** (K) 1 and 2 simultaneous-

ly, and while holding them down, press the **CLEAR/RESET** button (F).

Release all buttons, and the two Patterns will be cleared. Start the Rhythm, the TR-606 runs from #1 to #2 and back to #1. Set the **SCALE** switch (I) to 2 and push the **FUNCTION** button (J). While holding the **FUNCTION** button (J) down, press **SELECTOR Switch** (K) #16 to set a sixteen step pattern in #1 position. Repeat

the same procedures while the Rhythm runs to #2 position to set the same **SCALE** and **STEP** Number. You have just set up a Rhythm Pattern that extends over two Selector positions which gives you a total of 32 steps for the measure (each step now corresponding to a thirty-second note). **TAP** programming is easier in this case than Step programming.

Program the following Rhythm Program Score. (Shown in Fig. 6)

Fig. 6

Figure 6 consists of two parts: a Rhythm score and a Program score. The Rhythm score shows five staves labeled CH, OH, LT, SD, and BD, with musical notation for each. The Program score shows two bars, labeled '1st bar' and '2nd bar', with a grid of 16 steps for each instrument. The instruments listed are BD, SD, LT, OH, CH, and AC. The Program score shows the timing of notes for each instrument across the 16 steps of each bar.

Press **RUN/STOP** (H) when programming has been completed. As you can see, Chaining Rhythms are used to program a measure requiring more than 16 Steps. With the Clearing operation (pressing the **CLEAR/RESET** button (F)), both of the two Patterns are erased. When using Chained Rhythms, it is necessary to set up the **SCALE** and **STEP** number for each Rhythm used. However, the number of **STEPS** or **SCALE** of the Chained Rhythms do not have to be the same.

It is possible to select different **SCALE** and different **STEPS** for each Chained Rhythm by quickly changing the **SCALE** and **STEP** selection while the TR-606 runs from one Chained Rhythm to the other. This is usually most successful if it is done while the **TEMPO** is running fairly slowly.

Fig. 7

• Rhythm score

1st bar 2nd bar

[Step No]	1	2	3	4	5	6	7	8	9	10	11	12	1	2	3	4	5	6	7	8	9		
BD	•																						
SD																							
CH																							
AC																							

The easiest way to program a Chained Rhythm is to program each Rhythm Pattern individually, and then chain them together.

The Program Score in Figure 7 shows a Chained Rhythm in which the Rhythms have a different number of STEPs. To Program Figure 7, set the

SCALE at 3, and set the number of STEPs in the first Rhythm Pattern at 12 and the number of STEPs in the second Rhythm pattern at 9.

Fig. 8

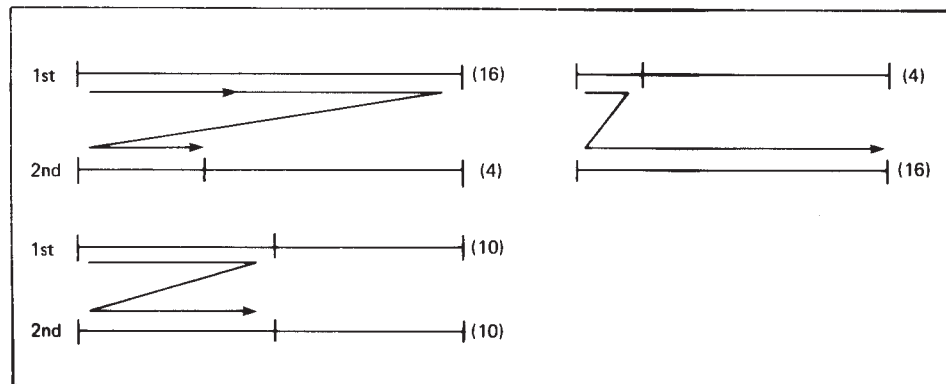

Figure 8 shows some alternate ways of setting up a Rhythm Pattern of 20 STEPs.

Composing the Rhythm Track

So far, we have used many of the TR-606 performance controls to produce creative and interesting results, but a function that completely sets the TR-606 apart from any other device is its ability to record an entire composition's percussion score (which we call the Rhythm Track).

A Rhythm Track is composed (as we call it) in real time, and in much the same way as you have programmed Rhythm Patterns, by using the Rhythm **SELECTOR** Switches (K) to change from one Programmed Rhythm to another. We will program a short Rhythm Track from some of the Rhythms you now have in memory.

Track Memory

The TR-606 contains eight different tracks which can be used for eight different songs or for a less number of songs longer in length. Each of the Tracks #1—7 contains enough memory storage capacity to create songs of up to 64 bars in length. For songs that are longer than 64 bars, these Tracks can be run together. Up to 4 Tracks can be chained in this manner to create songs of 256 bars in length (4 Tracks x 64 bars each = 256).

The last Track #8 contains more memory than any of the others having 256 bar storage when used by itself. However, even when chained with other Tracks, the maximum storage of the Chained Tracks remains at 256 bars.

Composing the Track

To compose a Track, first stop the Rhythm, then set the **MODE** Selector (B) to **TRACK WRITE** and select a Track to write into by rotating the **TRACK/INSTRUMENT** Selector (C). For now, begin with Track #1. By setting the **TRACK/INSTRUMENT** Selector (C) #1 position, you ensure that the Track you are

composing will begin on the first bar of Track 1.

Next, select from which **PATTERN GROUP** (N) you will be choosing Rhythms by pressing the **PATTERN GROUP** button (N). Only one Pattern Group can be selected for the Track. Re-set the first bar of the Track by pressing the **CLEAR/RESET** button (F). The **CLEAR/RESET** button (F) functions as **BAR RESET** when stopped.

Press the **RUN/STOP** button (H) and choose the Rhythm Pattern that will start the Track by pushing one of the **SELECTOR** Switches (K). You will hear the Rhythm Pattern begin to play, but it is not yet recorded into memory. The Rhythm Pattern selected will be recorded in the computer memory when you press the **TAP** button (M). This motion writes the Rhythm Pattern into memory, and advances the memory to the Next bar to be programmed. The track has now advanced to Bar #2 and the Rhythm Pattern playing is the Rhythm Pattern that was previously programmed in Bar #2. To change Bar #2 to another pattern, simply switch to another Rhythm Pattern and again press the **TAP** button (M), writing it into memory.

Chained Rhythm Patterns are selected in the same way as they were written, by pressing the first and last **SELECTOR** switches (K) in the chain simultaneously. All of the Chained Rhythms are memorized as a group by one press of the **TAP** button (M).

Continue switching Rhythm Patterns and logging them in memory by pressing the **TAP** button (M).

At the last bar, choose the last Rhythm Pattern, then press the **CLEAR/RESET** button (F) before pressing the **TAP** button (M). The **CLEAR/RESET** button (F) assigns the D.C. bar in the Track memory when running. Press the **TAP** button (M) and stop the Rhythm by

pressing the **RUN/STOP** button (H). Now, you have programmed the TRACK.

After pressing the **CLEAR/RESET** button (F) to re-set the TRACK to the 1st bar, and start the Rhythm, you can check the program from the 1st bar of the track by only pressing the **TAP** button (M). This allows you to manually step through the Track and if you find a wrong bar, choose the right Rhythm Pattern and press the **TAP** button (M) to write it into the TRACK memory. When the Rhythm stops the **TAP** button (M) increments the current bar.

Track Playback

To hear the Track you have just composed, set the **MODE** Selector (B) to **TRACK PLAY**, and press the **CLEAR/RESET** button (F) which re-sets the Track to the first bar. Press **RUN/STOP** (H) and the Track will begin playing back. Just as you had written it into memory. When the Track is finished, Press **RUN/STOP** (H).

The Pattern group is selected automatically.

Automatic Track Selection

When selecting a Track for a long composition, (more than 64 bars), all that is necessary is to select which Track will be the beginning of the composition. It is not necessary to manually switch to the next Track once you have used up the 64 bars of memory in the first Track. The switching will be done automatically for you.

Fig. 9

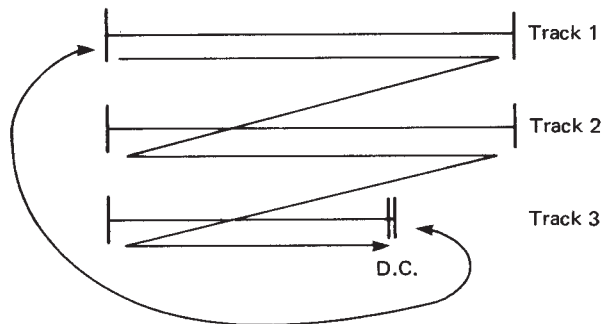

The D.S./D.C. Function

The D.S. function is one of the most important functions of the Track memory on the TR-606, as it allows the Track memory to be used sparingly. Should you have a song for which you are composing a Track in which the verses or verse/chorus combination is basically the same, the D.S. function allows you to repeat the whole segment of the song, rather than use up more memory by writing the same thing twice.

Fig. 10

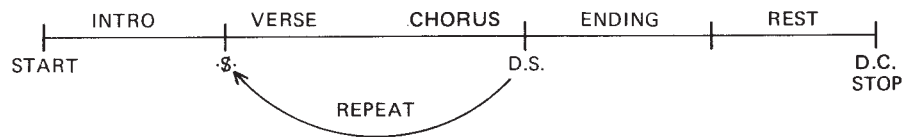

The D.S. function is applied by designating one bar in the Track as the **·\$· (sign) Bar**. This **·\$· Bar** is the bar that the Track goes to when the **TAP button (M)** is pressed during **TRACK PLAY**. The **·\$· Bar** is usually the **first bar** of the verse or chorus that is to be **repeated**.

Once the Track returns to the **·\$· Bar** and repeats the verse, it continues on **through** the end of the song unless the **TAP button (M)** is pressed again. The D.S. Function **can be activated** at any time during Track play, **and can be activated** either by the **TAP button (M)**.

At the end of the song, there is another designated bar, the **D.C. Bar**. The **D.C. Bar** should be the last bar in any Track. **After the D.C. Bar** plays, the Track automatically **resets** to the first bar of the Track, and plays **all over** again. There can be only one **·\$· Bar**, and one **D.C. Bar** for each Track.

Setting the ·\$· and D.C. Bars

To set the **·\$· Bar**, your **TR-606** must be in the **TRACK WRITE MODE** in **exactly** the same status as when you were **composing** the Rhythm Track. First, **select a Track**, reset the Track by pressing the **CLEAR/RESET button (F)** and start the Rhythm by **pressing RUN/STOP button (H)**.

Write a few different **Rhythm Patterns** into Track memory, and then **press the ·\$· PATTERN GROUP button (N)** (which **activates** the D.S. function) then press the **TAP button (M)** which will log that Pattern into **memory**. Once the **·\$· button** has been pressed, the **bar** has been designated as the **·\$· Bar**, and **will be** the bar the Track will set at when the **TAP button (M)** is pressed during **TRACK PLAY**.

Continue programming a **few more** Rhythm Patterns into memory and then **press the CLEAR/RESET button (F)** (which **activates** the D.C. function) and then **press the TAP button (M)**.

By pressing the **CLEAR/RESET** button (F) before pressing **TAP** button, the bar you have just played has been designated as the D.C. Bar.

NOTE: Press the **CLEAR/RESET** (D.C.) button or **PATTERN GROUP** (·\$·) button before pressing the **TAP** button. Otherwise, the bar will be advanced to the next bar.

To play the Track, press the **CLEAR/RESET** button (F), and start the Rhythm. When you press the **TAP** button (M), the Track will jump to the ·\$· Bar after finishing the bar that is playing. At the end of the Track, the bar you set as the D.C. Bar will play once, and then the Track will reset and play all over again from the first bar. To change a bar's designation as ·\$· or D.C., simply recompose the Track and designate another bar as ·\$· or D.C., the original D.S. or D.C. Bar's designation will be automatically erased.

Bar Selection Within the Track

A truly outstanding operating feature of the TR-606 is the facility to access any bar within a Track for editing, changing a ·\$·/D.C. designation or just to listen to a specific passage. This is accomplished by reading the LED display of the Bar Number, which up till now we have seen, but not described.

As mentioned earlier, for songs that are longer than 64 bar, these Tracks can be chained up to four Tracks (256 bar). You can select any bar within the chained Tracks and play or compose from the bar you selected.

DELETE, INSERT.

For example, we will call up Bar #115 in Track #3. Actually, the bar #115 is located in Track #4 because the capacity of each track is 64 measures (and in this case track #3 and #4 are chained). While the Rhythm is stopped, set the **MODE** Selector (B) to either **TRACK WRITE**

or **TRACK PLAY**. Set the **TRACK SELECTOR** to #3, which is the 1st track of the chained Track. Press the **FUNCTION** button (J) and hold it down. Press the **SELECTOR** Switch (K) corresponding to the following Bar designation written below them: #100, then #1 then #5. The **LED** indicators for #100 and #1 illuminates and #5 flashes. This indicates that you have set the Track at Bar #115. Release the **FUNCTION** button and press the **RUN/STOP** button. Then, you can hear the Rhythm from bar #115.

The D.C. and ·\$· bars can be designated by only pressing the **CLEAR/RESET** (F) or **PATTERN GROUP** (N) button respectively in the **TRACK WRITE MODE**.

DELETE and INSERT

Stop the Rhythm, set the **MODE** Selector to **TRACK WRITE**.

Select the Bar to be deleted or inserted in the same way as described above.

Release the **FUNCTION** button once, and press it again.

While holding down the **FUNCTION** button, press the **DEL** button. The selected bar will be deleted.

In the case of insert, press the **INS** button. This will split the Track memory at the selected bar and shift all of the contents of the rest of the rhythm track one bar to the right. Now you can change the rhythm in the selected bar to a new one. Press the **RUN/STOP** button and select the new Rhythm Pattern by pressing the **SELECTOR** switch (K) and press the **TAP** button (M).

For example:—

If you mistakenly missed bar 4

e.g. A B C E F G

Then call up the fourth bar using Bar Selection, and press **FUNCTION** and **INSERT**.

e.g. A B C E E F G

Then you can change bar 4 to its correct rhythm.

e.g. A B C D E F G

Displaying ·\$· and D.C. bar

While the rhythm is stopped, ·\$· and D.C. bar can be displayed by the **LED** indicators.

While holding down the **FUNCTION** button, press the **PATTERN GROUP** or **CLEAR/RESET** button respectively.

STEP & SCALE

About step and scale

With a TR-606, each measure is divided into a certain number of parts which we call STEPS and each step corresponds to each **SELECTOR** Switch (K).

Fig. 1 Division of one bar. (cf. Basic Course)

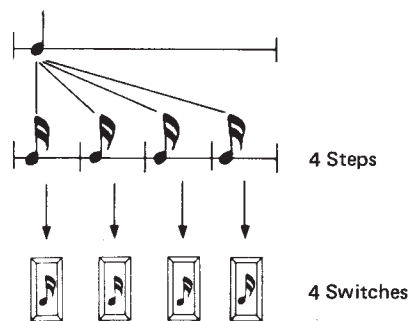

* In case of dividing one bar (♩) into 4 steps, one step corresponds to the semiquaver (♩) or the semiquaver rest (♩).

With a TR-606, the Scale Selector determines the number of steps assigned to each quarter note. The Scale (1) must be chosen to match the minimum division of the note to be used in the rhythm pattern. For example, though both rhythm patterns "♩♩♩♩" and "♩♩♩" are the same as one note (♩), each step has a different value in performance with the same TEMPO. Therefore, each step for two rhythm patterns of "♩♩♩♩" and "♩♩♩" must be set to a different value to perform with the same Tempo.

Selecting the number of steps for one note (♩).

The number of steps for one note (♩) can be selected according to any rhythm patterns. With a TR-606, 4 kinds of SCALE can be Selected by the Scale Selector on the panel. (cf. Fig. 2)

Caution

Be sure to set the **SCALE SELECTOR** to the correct position, if not, then a crotchet will have the wrong time value. If a mistake has been made, the scale can easily be changed by

following these steps.

1. Set **MODE** Selector (B) to **PATTERN WRITE**.
2. Select the rhythm pattern which has incorrect scale.
3. Push **RUN/STOP** button to start rhythm.
4. Select correct Scale.
5. Press **FUNCTION** button.

Setting Last Step

The number of steps for one note (♩) of selected Scale multiplied by the number of notes for one measure makes Last Step.

Fig. 2

Scale No.	Panel (One note)	The number of steps for one note (= switch)	The length of one step (= switch)
1		4	(♩ divided by 4 = ♩)
2		8	(♩ divided by 8 = ♩)
3		3	(♩ divided by 3 = ♩)
4		6	(♩ divided by 6 = ♩)

Writing rhythm patterns for each Scale

1. To write a rhythm pattern using Scale 1.

Ex. 1: Scale 1, Last Step 12.

CH
OH
SD
BD

1st bar

Step No	1	2	3	4	5	6	7	8	9	10	11	12
BD												
SD												
CH												
AC												

The TR-606 can accommodate odd rhythms (5/4, 7/8, etc..) that require more than sixteen steps for programming by assigning them to two adjacent rhythm patterns.

Ex. 2: Scale 1, Last Step 20

CH
OH
SD
BD

1st bar

Step No	1	2	3	4	5	6	7	8	9	10	11	12	13	14	15	16
BD																
SD																
OH																
CH																
AC																

(Last Step → 16)

2nd bar

Step No	1	2	3	4
BD				
SD				
OH				
CH				
AC				

(Last Step → 4)

2. To write a rhythm pattern using Scale 2.

Ex. 3: Scale 2, Last Step 32

CH
OH
SD
BD

1st bar

Step No	1	2	3	4	5	6	7	8	9	10	11	12	13	14	15	16
BD																
SD																
LT																
OH																
CH																
AC																

2nd bar

Step No	1	2	3	4	5	6	7	8	9	10	11	12	13	14	15	16
BD																
SD																
LT																
OH																
CH																
AC																

3. To write a rhythm pattern using Scale 3.

Ex. 4: Scale 3, Last Step 12

CH
OH
SD
BD

1st bar

Step No	1	2	3	4	5	6	7	8	9	10	11	12
BD												
SD												
OH												
CH												
AC												

4. To write a rhythm pattern using Scale 4.

Ex. 5: Scale 4, Last Step 24

CH
OH
SD
BD

1st bar

Step No	1	2	3	4	5	6	7	8	9	10	11	12
BD												
SD												
OH												
CH												
AC												

2nd bar

Step No	1	2	3	4	5	6	7	8	9	10	11	12
BD												
SD												
OH												
CH												
AC												

5. To write a rhythm pattern using two Scales.

Ex. 6: Scale 1, Last Step 8

Scale 4, Last Step 12

CH
OH
SD
BD

1st bar

Step No	1	2	3	4	5	6	7	8
BD								
SD								
OH								
CH								
AC								

Scale → 1
Last Step → 8

2nd bar

Step No	1	2	3	4	5	6	7	8	9	10	11	12
BD												
SD												
OH												
CH												
AC												

Scale → 4
Last Step → 12

SAMPLE RHYTHMS

● 1. TANGO (SCALE → 1, LAST STEP → 16)

Step No	1	2	3	4	5	6	7	8	9	10	11	12	13	14	15	16
BD	●				●				●				●			●
SD	●				●				●				●			●
AC	▲				▲				▲				▲			▲

● 2. ENKA (SCALE → 1, LAST STEP → 16)

Step No	1	2	3	4	5	6	7	8	9	10	11	12	13	14	15	16
BD	●				●				●				●			●
SD	●				●				●				●			●
CH	●				●				●				●			●
AC	▲				▲				▲				▲			▲

● 3. HABANERA (SCALE → 1, LAST STEP → 16)

Step No	1	2	3	4	5	6	7	8	9	10	11	12	13	14	15	16
BD	●				●				●				●			●
SD	●				●				●				●			●
CH	●				●				●				●			●
AC	▲				▲				▲				▲			▲

● 4. MAMBO (SCALE → 1, LAST STEP → 16)

Step No	1	2	3	4	5	6	7	8	9	10	11	12	13	14	15	16
BD	●				●				●				●			●
LT																
HT																
OH	●				●				●				●			●
CH	●				●				●				●			●
AC	▲				▲				▲				▲			▲

ADVANCED COURSE (Cont'd)

● 5. DISCO (SCALE → 1, LAST STEP → 16)

Step No	1	2	3	4	5	6	7	8	9	10	11	12	13	14	15	16
BD	●															
SD					●											
OH																
CH	●															
AC	●	●			●			●					●			

● 6. ROCK'N ROLL (SCALE → 1, LAST STEP → 16)

Step No	1	2	3	4	5	6	7	8	9	10	11	12	13	14	15	16
BD	●															
SD					●											
CH	●															
AC	●															

● 7. INTRO/FILLIN (SCALE → 1, LAST STEP → 16)

Step No	1	2	3	4	5	6	7	8	9	10	11	12	13	14	15	16
BD	●															
SD					●											
OH																
CH	●															
AC	●	●			●			●					●			

● 8. INTRO/FILLIN (SCALE → 1, LAST STEP → 16)

Step No	1	2	3	4	5	6	7	8	9	10	11	12	13	14	15	16
BD	●															
SD					●											
LT																
HT																
AC	●															

ADVANCED COURSE (Cont'd)

● 9. BOSSA NOVA (SCALE → 1, LAST STEP → 16)

Step No	1	2	3	4	5	6	7	8	9	10	11	12	13	14	15	16
BD	•															
SD																
OH																
CH																
AC																

Step No	1	2	3	4	5	6	7	8	9	10	11	12	13	14	15	16
BD	•															
SD																
OH																
CH																
AC																

● 10. ROCK (SCALE → 2, LAST STEP → 32)

Step No	1st bar																2nd bar															
Step No	1	2	3	4	5	6	7	8	9	10	11	12	13	14	15	16	1	2	3	4	5	6	7	8	9	10	11	12	13	14	15	16
BD	•																•															
SD																																
OH																																
CH																																
AC																																

● 11. ROCK (SCALE → 2, LAST STEP → 32)

Step No	1st bar																2nd bar															
Step No	1	2	3	4	5	6	7	8	9	10	11	12	13	14	15	16	1	2	3	4	5	6	7	8	9	10	11	12	13	14	15	16
BD	•																•															
SD																																
OH																																
CH																																
AC																																

ADVANCED COURSE (Cont'd)

● 12. INTRO/FILLIN (SCALE → 2, LAST STEP → 32)

Musical notation for exercise 12. The notation includes four staves: HT (Hi Tom), LT (Low Tom), SD (Snare Drum), and BD (Bass Drum). The first two bars are labeled "1st bar" and "2nd bar".

Step No	1	2	3	4	5	6	7	8	9	10	11	12	13	14	15	16
BD																
SD	•	•	•	•	•	•	•	•	•	•	•	•	•	•	•	•
LT																
HT																
AC	•															

● 13. SLOW ROCK (SCALE → 3, LAST STEP → 12)

Musical notation for exercise 13. The notation includes three staves: CH (Charleston), SD (Snare Drum), and BD (Bass Drum). The notation shows triplet patterns.

Step No	1	2	3	4	5	6	7	8	9	10	11	12
BD	•											
SD												
CH	•	•	•	•	•	•	•	•	•	•	•	•
AC	•											

● 14. ROCK $\frac{7}{4}$ (SCALE → 3, LAST STEP → 21)

Musical notation for exercise 14. The notation includes three staves: CH (Charleston), SD (Snare Drum), and BD (Bass Drum). The notation shows 7/4 time signatures.

Step No	1	2	3	4	5	6	7	8	9	10	11	12	1	2	3	4	5	6	7	8	9
BD	•												•								
SD																					
CH	•	•	•	•	•	•	•	•	•	•	•	•	•	•	•	•	•	•	•	•	•
AC	•												•								

● 15. SHUFFLE (SCALE → 3, LAST STEP → 12)

Musical notation for exercise 15. The notation includes three staves: CH (Charleston), SD (Snare Drum), and BD (Bass Drum). The notation shows shuffle patterns.

Step No	1	2	3	4	5	6	7	8	9	10	11	12
BD	•											
SD												
CH	•	•	•	•	•	•	•	•	•	•	•	•
AC	•											

ADVANCED COURSE (Cont'd)

● 16. ROCK $\frac{5}{4}$ (SCALE → 3, LAST STEP → 15)

CY 

LT 

SD 

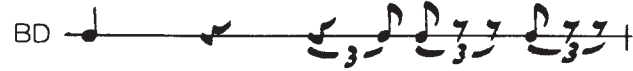
BD 

Step No → 1 2 3 4 5 6 7 8 9 10 11 12 13 14 15

BD	●														
SD		●													
LT															
CY	●	●				●	●	●	●	●	●	●	●	●	●
AC	●	●	●	●	●	●	●	●	●	●	●	●	●	●	●

● 17. BOOGIE (SCALE → 3, LAST STEP → 12)

OH 

SD 

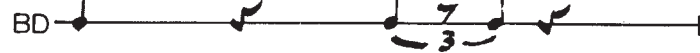
BD 

Step No → 1 2 3 4 5 6 7 8 9 10 11 12

BD	●						●	●	●	●		
SD			●	●	●	●	●	●	●	●	●	●
OH	●	●	●	●	●	●	●	●	●	●	●	●
AC	●	●	●	●	●	●	●	●	●	●	●	●

CY 

LT 

SD 

BD 

Step No → 1 2 3 4 5 6 7 8 9 10 11 12 13 14 15

BD	●														
SD		●													
LT															
CY	●	●				●	●	●	●	●	●	●	●	●	●
AC	●	●	●	●	●	●	●	●	●	●	●	●	●	●	●

● 18. ROCK (SCALE → 4, LAST STEP → 24)

CH 

OH 

SD 

BD 

1st bar 2nd bar

Step No → 1 2 3 4 5 6 7 8 9 10 11 12 1 2 3 4 5 6 7 8 9 10 11 12

BD	●												●										
SD													●										
OH	●	●	●	●	●	●	●	●	●	●	●	●	●	●	●	●	●	●	●	●	●	●	●
CH	●	●	●	●	●	●	●	●	●	●	●	●	●	●	●	●	●	●	●	●	●	●	●
AC	●	●	●	●	●	●	●	●	●	●	●	●	●	●	●	●	●	●	●	●	●	●	●

ADVANCED COURSE (Cont'd)

● 19. ROCK (SCALE → 4, LAST STEP → 24)

1st bar 2nd bar

Step No	1	2	3	4	5	6	7	8	9	10	11	12	1	2	3	4	5	6	7	8	9	10	11	12
BD	•												•											
SD							•												•					
OH																								
CH	•		•							•			•		•							•		
AC	•	•					•			•			•	•					•			•		

1st bar 2nd bar

Step No	1	2	3	4	5	6	7	8	9	10	11	12	1	2	3	4	5	6	7	8	9	10	11	12
BD																								
SD							•												•					
OH																								
CH	•		•							•			•		•							•		
AC	•	•					•			•			•	•					•			•		

● 20. RHYTHM used over 2 scales

1st bar

Step No	1	2	3	4	5	6	7	8	9	10	11	12	13	14	15	16
BD																
SD	•	•	•	•	•	•	•	•	•	•	•	•	•	•	•	•
LT																
HT																
CY																
AC	•															

[SCALE → 2
LAST STEP → 16]

2nd bar

Step No	1	2	3	4	5	6	7	8	9	10	11	12
BD							•					
SD												
LT												
CY	•	•	•									
AC	•						•					

[SCALE → 4
LAST STEP → 12]

● 21. RHYTHM used over 2 scales

1st bar

Step No. →	1	2	3	4	5	6
BD	●					
SD						
LT						
HT						
OH			●			
CH	●	●				
AC			●			

[SCALE → 1]
[LAST STEP → 4]

2nd bar

Step No. →	1	2	3	4	5	6
BD						
SD	●					
LT						
HT						
OH				●		
CH	●	●	●	●		
AC				●		

[SCALE → 4]
[LAST STEP → 6]

3rd bar

Step No. →	1	2	3	4	5	6	7	8	9	10	11	12	13	14	15	16
BD	●				●											
SD									●							
LT													●			
HT												●				
OH										●						
CH	●	●	●	●	●	●	●	●	●	●	●	●	●	●	●	●
AC					●								●			

[SCALE → 2]
[LAST STEP → 16]

ADVANCED COURSE (Cont'd)

● (SCALE → , LAST STEP →)

<input type="text"/>	_____
<input type="text"/>	_____
<input type="text"/>	_____
<input type="text"/>	_____
<input type="text"/>	_____
<input type="text"/>	_____

Step No	→	1	2	3	4	5	6	7	8	9	10	11	12	13	14	15	16
<input type="text"/>																	
<input type="text"/>																	
<input type="text"/>																	
<input type="text"/>																	
<input type="text"/>																	
<input type="text"/>																	
<input type="text"/>																	
<input type="text"/>																	

● (SCALE → , LAST STEP →)

<input type="text"/>	_____
<input type="text"/>	_____
<input type="text"/>	_____
<input type="text"/>	_____
<input type="text"/>	_____
<input type="text"/>	_____

Step No	→	1	2	3	4	5	6	7	8	9	10	11	12	13	14	15	16
<input type="text"/>																	
<input type="text"/>																	
<input type="text"/>																	
<input type="text"/>																	
<input type="text"/>																	
<input type="text"/>																	
<input type="text"/>																	
<input type="text"/>																	

ADVANCED COURSE (Cont'd)

Specifications

- **TR-606** □ **DRUMATIX**
 - **Memorized Rhythm Number**
32 Basic Rhythms
(16 x Pattern Group I & II)
 - **Step Number/1 measure**
1 ~ 16 steps
 - **Rhythm Track**
64 measures x 7 tracks
256 measures x 1 track
(Continuous Maximum 256 measures)
 - **Sound Source**
Bass Drum (BD)
Snare Drum (SD)
Low Tom (LT)
High Tom (HT)
CYmbal (CY)
Open Hi-Hat (OH)
Closed Hi-Hat (CH)
ACcent (AC)
 - **Control Switches, Buttons and Indicators**
 - **MODE** Selector
(Pattern Write, Pattern Play, Track Write, Track Play)
 - **TRACK/INSTRUMENT** Selector
(AC¹, BD², SD³, LT⁴, ⁵HT, ⁶CY, ⁷OH, ⁸CH)
 - **TEMPO** Control
(♩ = 40 ~ 300)
 - **INSTRUMENT** Mix Control
(ACcent, Bass Drum, Snare Drum, L.H. Tom, CYmbal, O.C. Hihat)
- **POWER** Switch/**VOLUME** Control
- **CLEAR/RESET** button
PATTERN CLEAR
D.C. Setting
bar reset
- **RUN/STOP** button
- **BATTERY** Check/**RUN** Indicator
- **SCALE** Selector
(1, 2, 3, 4)
- **FUNCTION** button
Last Step Setting
Scale Setting
Bar Number, (Be sure the bar number of ·\$, D.C.)
- **SELECTOR** Switch x 16
RHYTHM Selector
Designated Bar Number Switch
DEL, INS switch
Setting the Last Steps
- **Indicators**
- **Pattern Group** button
Group Selector
Setting the ·\$
- **PATTERN** Group Indicators
- **TAP** button
Write/Next
TAP
Step Re-set
D.S. button
- **Connection Jacks**
 - DC 9V x 1
AC Adapter-jack (BOSS ACA Battery Eliminator)
- Output x 1
 - Regular-jack
 - Output level
(**POWER** Switch/**VOLUME** Control; **MAX**, Instrument Mix Control; Center)
2 Vp-p (ACcent; MIN)
6Vp-p (ACcent; MAX)
 - Output Impedance
1 kΩ
 - Headphone x 1
 - Stereo-jack
 - Conformity Impedance 8Ω ~ 30Ω
 - **TRIGGER OUT** x 2
Mini-jack (HT, LT; +14V, 20 mSec pulse)
 - Sync x 1
DIN-Connector (for CSQ-600, MC-4)
1: RUN/STOP, 2: GND, 3: CLOCK
 - **INPUT OUTPUT** selector x 1
 - **RUN/STOP** x 1
(DP-2)
- **Power**
Battery 6V (UM-2 Size (C) R-14 or equal battery x 4)
(AC Adapter: 9V)
- **Consumption Current draw**
70mA (MIN) ~ 150mA (MAX)
- **Dimensions**
300(W) x 146(D) x 55(H) mm
- **Weight**
3.7 kg

Accessories

- Compact Soft Case x 1
- Connection Cord (PJ-1) x 1

Option

- AC-Adapter
- Boss ACA Eliminator
- Headphone
RH-10
- Pedal Switch
DP-2

