

Roland®

SETTING UP

Roland's Compact Drum System TD-5 Kit (TD-5K)

Thank you, and congratulations on your choice of the Roland Compact Drum TD-5 Kit. This document guides you through assembly of the drum system, and goes on to introduce a few basics so you can start playing right away. First of all, though, please take the time to read this manual. For a detailed explanation of each piece of equipment, please refer to the respective manuals.

< Compact Drum TD-5 Kit (TD-5K) >

The TD-5K consists of the following:

TD-5K

TD-5 (Percussion Sound Module) x 1
PD-5 (Pad) x 5
KD-5 (Kick Trigger Unit) with beater x 1
FD-7 (Hi-Hat Control Pedal) x 1
MDH-7 (Pad Holder) x 1

MDS-7 (Compact Drum Stand) x 1
MDY-7 (Cymbal Holder Set) x 1

** Note that not all Kits include the MDY-7.*

PD-5

Dimensions: 222 (W) x 282 (D) x 61 (H) mm
8-3/4 (W) x 11-1/8 (D) x 2-7/16 (H) inches
Weight: 800 g / 1 lb 13 oz

KD-5

Dimensions: 172 (W) x 112 (D) x 100 (H) mm
6-13/16 (W) x 4-7/16 (D) x 3-15/16 (H) inches
Weight: 1200 g / 2 lbs 11 oz (including the beater)

FD-7

Dimensions: 170 (W) x 394 (D) x 170 (H) mm
6-3/4 (W) x 15-9/16 (D) x 6-3/4 (H) inches
Weight: 1910 g / 4 lbs 4 oz

< Important Notes (for PD-5 / KD-5 / FD-7) >

- Do not subject the unit to temperature extremes (e.g., direct sunlight in an enclosed vehicle). Avoid using or storing the unit in dusty or humid areas.
- Do not install the unit near devices that radiate heat.
- Although the PD-5, KD-5, and FD-7 were carefully designed so as to reduce to the absolute minimum the unwanted sound that might be produced when played (impact and other operational sounds), such repetitive sounds can quite easily be transmitted through floors and walls, even when their level is minimal. For this reason, we suggest that you exercise caution (especially in the late hours of the night) to avoid disturbing others within your residence or the immediate neighborhood.

** Please make sure to also refer to the "Important Notes" for the TD-5, in the TD-5 Owner's Manual.*

Assembling the Compact Drum Stand

- Before starting, identify the left (L) and right (R) sides, as marked with stickers on top of the upright tube.
- Adjust the stand to any position desired by loosening the clamp knobs and rotating the fittings. Be sure to re-tighten the clamp knobs when you achieve the setup you want.
- * *Slight modifications may have been made in the parts making up the Drum Stand, or the shape of the holder, so the illustration may not provide an exact depiction. If that seems to be the case, please refer to the instructions that came with the Drum Stand instead when assembling it.*
- * *Note that not all Kits include the MDY-7.*

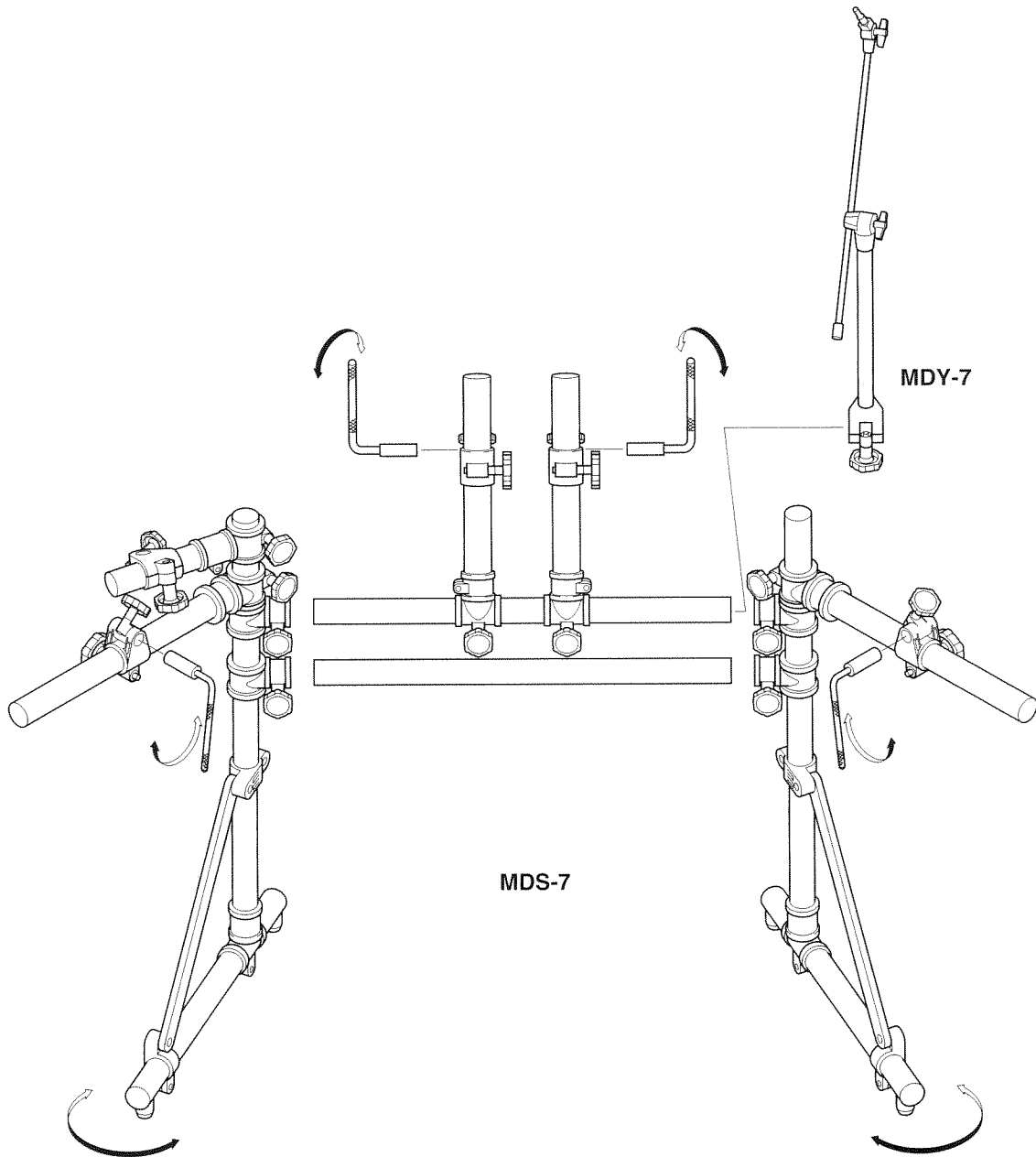

Assembling the TD-5 Kit

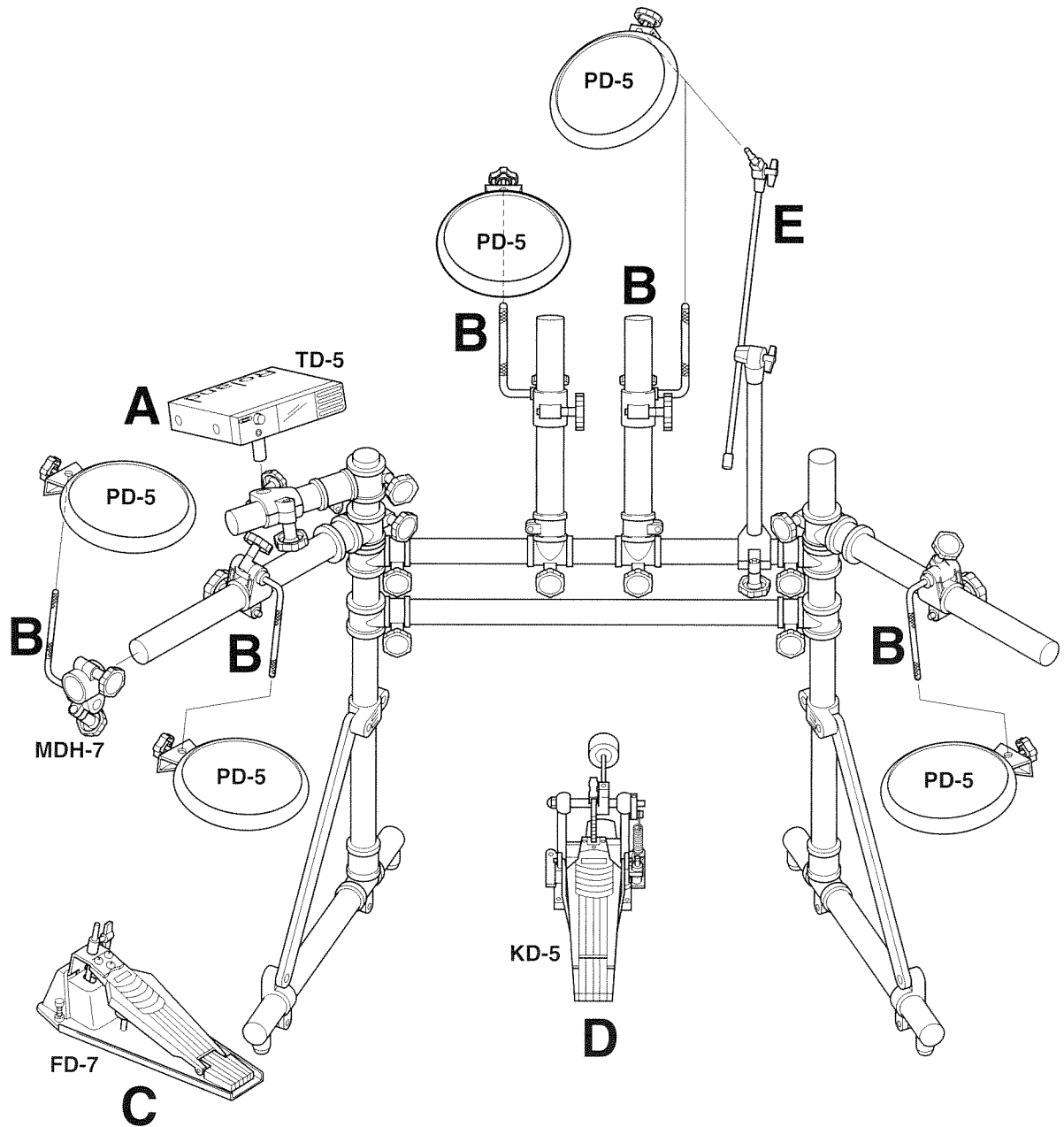

- A** Fix the TD-5 in place using the supplied screws (M5 x 8 mm).
Never use any other screws, as damage could result to the TD-5.

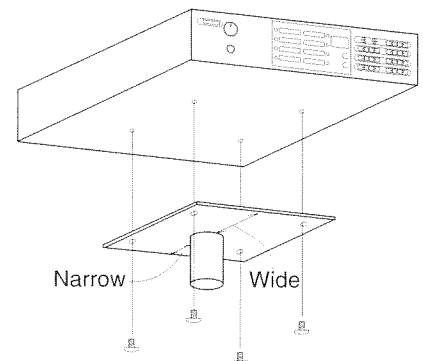

Assembling the TD-5 Kit

B Slide the PD-5s over the rods, and secure them in place with the fastening knobs.

C With the FD-7, you can adjust the amount of resistance the pedal delivers by turning the Load Control Nut. Also, you can adjust the travel of the pedal by changing the length of the Rod.

** When the FD-7 is not going to be used for a long period of time, set the Rod as shown in (b). Do not leave the FD-7 with the Pedal Plate depressed for a long period of time.*

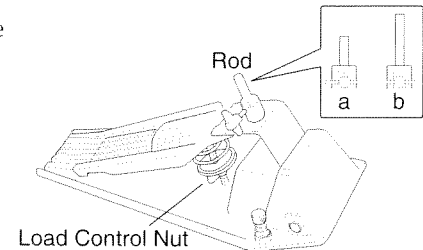

D The KD-5 needs to be inserted onto the end of your kick-pedal. The beater (an accessory) should be connected as shown.

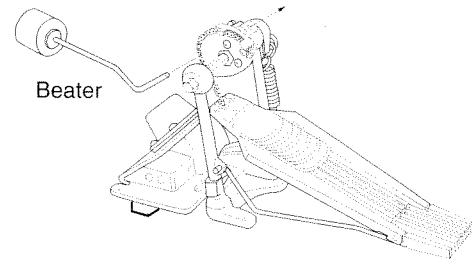

If using the KD-5 on a carpeted (pile) floor, you can stick the supplied attaching Velcro strip onto the bottom of the KD-5 so it stays in place (see illustration at right). Before affixing the strip, make sure to wipe the bottom surface so it is free of all dust, oil, or moisture. Try to allow about 24 hours for the adhesive to dry before using it. If you do need to use the pedal during this time, you will have to be very careful, since the strip might easily loosen and come off if the pedal moves.

Note that the strip is not necessary if the KD-5 is going to be used on a floor with a hard surface.

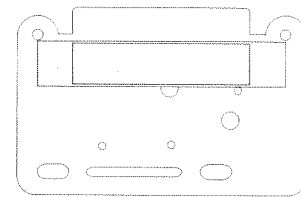

KD-5 Bottom View

E The washers and cushions supplied with the MDY-7 are included so you can mount acoustic cymbals. Although they are not essential for a Pad setup, you should attach them as shown below so they do not get lost.

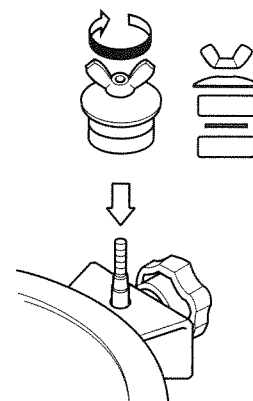

Assembling the TD-5 Kit (System Upgrade)

The following introduces an example of how you could upgrade your system and get more out of the features available on the TD-5.

After adding a PD-7 or PD-9 (dual-trigger Pads), you can obtain two crash cymbal sounds (including choke); or can obtain both the snare and rim shot sounds from the snare drum.

To install the new cymbal Pad(s), you will also need Cymbal Holder Set(s) (MDY-7).

A The washers and cushions supplied with the MDY-7 are included so you can mount acoustic cymbals. Although they are not essential for a Pad setup, you should attach them as shown below so they do not get lost.

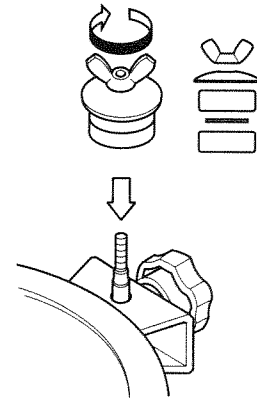

B To change the MDY-7's angle, loosen the clamp.

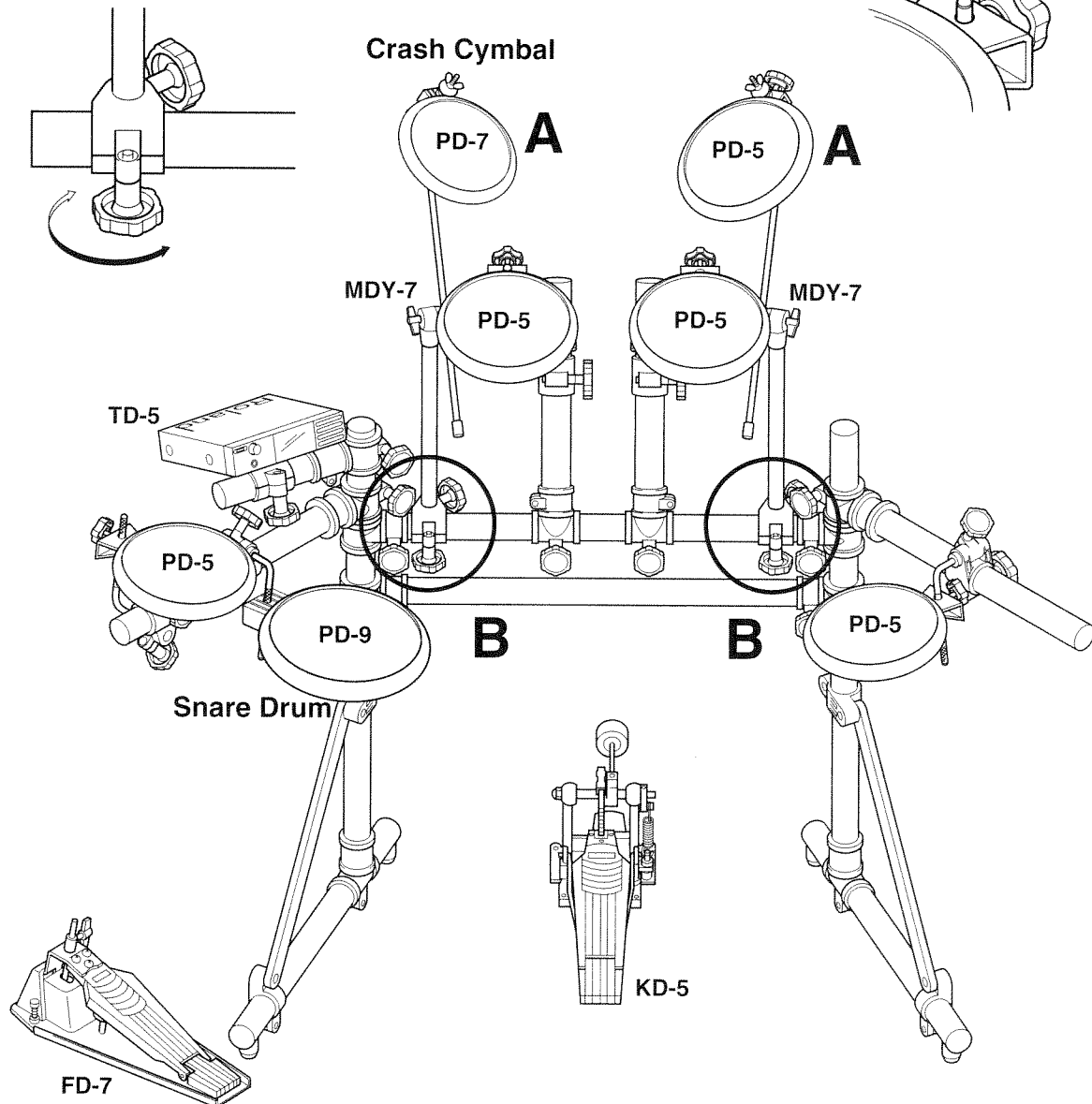

Connections

Before connecting anything, be sure that the power is OFF on all of the equipment in your system. You risk damaging speakers or other equipment if you make connections while the power is ON. After everything has been connected, use the cable ties (supplied with MDS-7) to fix the cables to the drum stand.

- * Be sure to use only the AC adaptor supplied with the unit. Use of any other power adaptor could result in damage, malfunction or electric shock.
- * By using a PD-7 or PD-9, you will be able obtain rim-shot and choke (abrupt mute of the sound) style effects. For these types of effects to work, you will need to connect the Pads to the TD-5 using the cables supplied with them (with stereo 1/4" phone plugs).

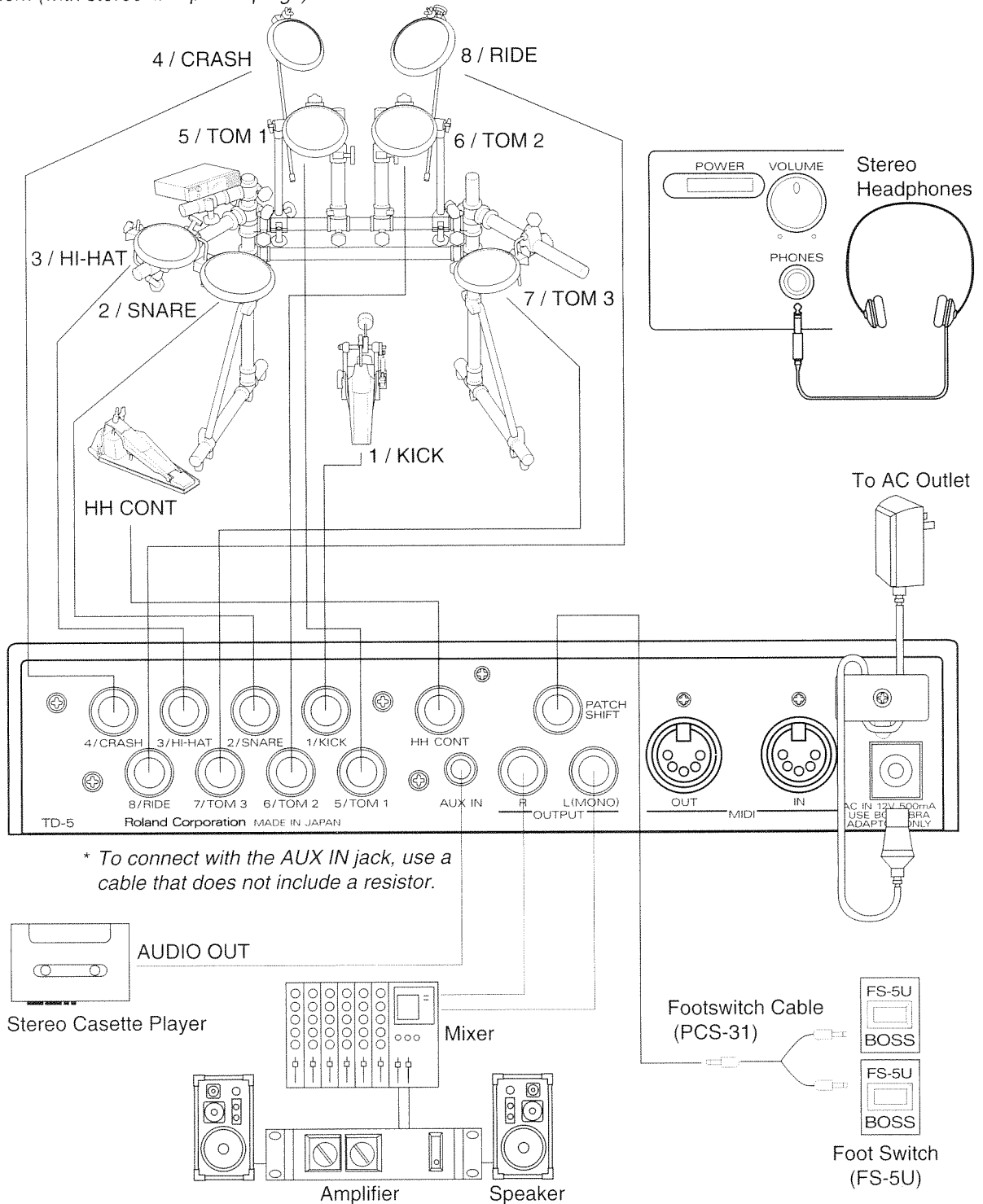

Playing the Pads

First, turn ON the TD-5, then turn on all the connected units.

** After you turn on the TD-5's power, you need to wait until the Patch Number is displayed before hitting any Pads or stepping on any pedals.*

If you start playing before this screen has appeared, the sound you obtain might be softer than you would normally expect, or might be wrong altogether. Should you encounter this problem, you will need to turn the power OFF, then ON again, and then wait until the Patch Number is displayed.

** When powering down your system, turn OFF all peripheral units first, then turn OFF the TD-5.*

You can now start playing the Pads (and depressing the pedals) to check out how your new kit sounds.

** When using the PD-7, set the Trigger Type to "Pd7," and for the PD-9, set it to "Pd9." With the Trigger Type set correctly, the unit will be able to provide the right kind of response, one that is geared to the characteristics of the Pad. For instructions on how to make this setting, see "Choosing the Pad Type (TRIGGER TYPE - tyP)" in the TD-5's manual.*

<Hi-Hat Effects>

By hitting the Hi-Hat pad while you depress the Hi-Hat Control Pedal, you can express the range of sound between open and closed hi-hats. You can also step on the Hi-Hat Control Pedal alone to obtain a pedal hi-hat sound.

<Changing Patches>

On the TD-5, a "Patch" is a group of settings that determines what instrument sounds are assigned to which Pads, and certain details about the way the sounds are to be produced. All you need to do is select a Patch number, and you can instantly obtain the whole group of settings it provides. Try out some of the unit's 32 different Patches (see next page).

Confirm that the [EDIT] button is not lighted (Play mode). If lighted, press [EDIT] to turn it off. The Patch Number is shown in the display. To change to another Patch number, use the PATCH [◀][▶] buttons.

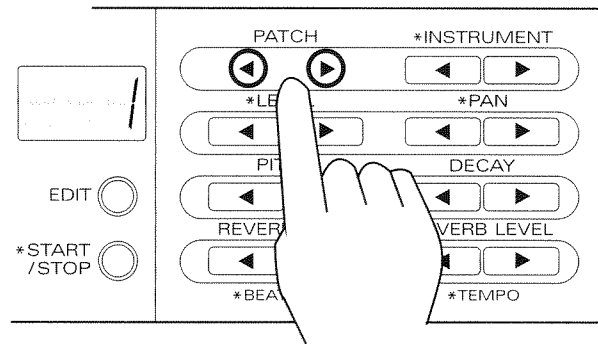

Playing the Pads

<Rim Shot (for PD-7 or PD-9)>

Next, try the Rim Shot effect. To produce a rim shot, you need to strike both the head and the rim of the pad at the same time. You won't obtain the right sound if you hit only the rim.

* *The Rim Shot effect cannot be obtained using the PD-5.*

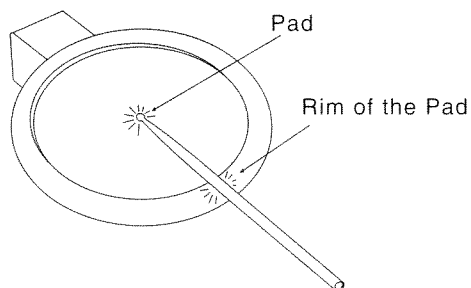

<Choke effect (for PD-7 or PD-9)>

The Choke effect is obtained by grasping the rim of a pad immediately after you hit it, thus silencing the sound right after it has been produced.

* *The Choke effect cannot be obtained using the PD-5.*

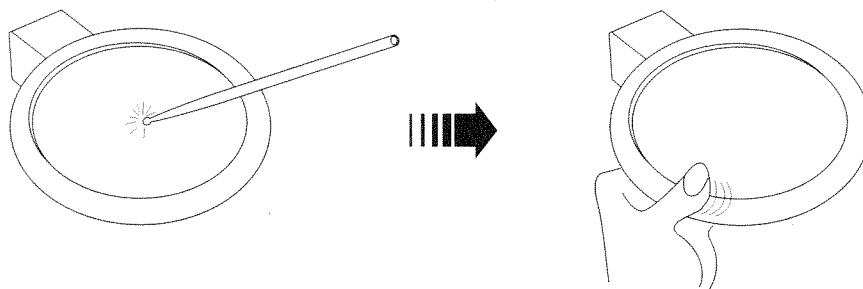

Patch List

Patch #	Patch Name	Patch #	Patch Name	Patch #	Patch Name	Patch #	Patch Name
1	Real 1	9	Room	17	Power	25	Euro Beat
2	Real 2	10	Hard Rock	18	Metal	26	TR-808
3	Rock 1	11	Fusion 1	19	Ballad	27	TR-909
4	Rock 2	12	Fusion 2	20	Blues	28	Reggae
5	Funk 1	13	R&B	21	Rockabilly	29	Ethnic Pop
6	Funk 2	14	Rap	22	Country	30	Percussion 1
7	Jazz	15	Dance	23	Oldies	31	Percussion 2
8	Brushes	16	Grungy	24	Electronic	32	Percussion 3

 Roland®

00564678

UPC 00564678



18981

 Roland®