

## Owner's Manual

### Introduction

Thank you, and congratulations on your choice of the TD-5 Percussion Sound Module. After connecting Pads, Kick Trigger Units, and Hi-hat Control Pedals to the TD-5 drum sound module, it allows you to enjoy realistic performances of percussion instruments. To take full advantage of the many functions the TD-5 has to offer, please read through this manual carefully.

### Features of the TD-5

**High-quality 16-bit sounds with a superior dynamic range**

**Offers 210 sounds covering every musical genre**

**Realizes efforts in developing an acoustic feel**

- Volume and timbre can be controlled realistically by varying the force with which the Pads are struck. This allows for greater expressiveness, whether when playing unrestrained, or when attempting more subtler nuances. You can even use the Pedal Closed Hi-hat and Pedal Open hi-hat techniques.
- When a Hi-hat Control Pedal (FD-7; sold separately) is connected, you gain continuous control (from closed to open) over the Hi-hat sounds.
- Using the PD-7 or PD-9 Pads allows you to use playing techniques such as rim shots and cymbal chokes (whereby the cymbal is struck and then grabbed by hand to cut off the sound).
- The interval between striking a Pad and production of the sound is a fast 0.003 second.

#### Simple operation

- You can switch instantly to any of the 32 Patches (Drum Sets) available.
- Even players unfamiliar with electronic instruments can start playing immediately.
- The TD-5 is designed so it is equipped with only the needed functions, thus creating a streamlined design.

#### Eight Trigger Input jacks (stereo)

#### Provides high-quality reverb

#### Includes a metronome function, helpful for practicing

#### Equipped with jacks that increase the TD-5's usefulness

- The AUX IN jack lets you mix sounds with a headphone stereo or other audio device (The mix can be heard only through headphones.).
- The PATCH SHIFT jack allows you to connect a foot switch for changing Patches up or down.
- When one or more Drum Triggers is connected to the TRIGGER INPUT jacks, the TD-5 can function as an acoustic trigger..to - MIDI interface.

PATCH#	PATCH NAME	PATCH#	PATCH NAME	PATCH#	PATCH NAME	PATCH#	PATCH NAME
1	Real 1	9	Room	17	Power	25	Euro Beat
2	Real 2	10	Hard Rock	18	Metal	26	TR-808
3	Rock 1	11	Fusion 1	19	Ballad	27	TR-909
4	Rock 2	12	Fusion 2	20	Blues	28	Reggae
5	Funk 1	13	R&B	21	Rockabilly	29	Ethnic Pop
6	Funk 2	14	Rap	22	Country	30	Percussion 1
7	Jazz	15	Dance	23	Oldies	31	Percussion 2
8	Brushes	16	Grungy	24	Electronic	32	Percussion 3

Copyright © 1994 Roland Corporation

All rights reserved. No part of this publication may be reproduced in any form without the written permission of Roland Corporation.

# Table of Contents

---

Important Notes .....	4
Panel Descriptions .....	6
About External Drum Pads and Kick Trigger Units.....	9
Attaching the TD-5 to a Drum Stand.....	10
<b>Chapter 1 Playing the TD-5 .....</b>	<b>11</b>
1 Connection to Audio Equipment.....	11
2 Turning the Power On and Off .....	12
3 Adjusting the Volume.....	12
4 Playing the Pads.....	13
5 Changing the Sound (Changing the Patch [Drum Set]).....	14
6 Using a Hi-hat Control Pedal.....	15
<b>Chapter 2 Changing the Sound Played by a Pad (Edit Mode).....</b>	<b>16</b>
Play Mode and Edit Mode.....	16
Patches and Sound Parameters .....	16
1 Changing the Instruments Assigned to a Pad.....	17
2 Changing the Way an Instrument Sound .....	18
1. Adjusting the Volume (LEVEL).....	18
2. Adjusting the Stereo Position (PAN).....	18
3. Adjusting the Pitch (PITCH) .....	18
4. Adjusting the Decay Time (DECAY) .....	18
5. Selecting a Reverb Type (REVERB TYPE) .....	19
6. Adjusting the Reverb Depth (REVERB LEVEL) .....	19
[Making the Settings].....	20
3 Copying a Patch (Drum Set).....	21
<b>Chapter 3 Using the Metronome .....</b>	<b>22</b>
1 Starting and Stopping the Metronome .....	22
2 Metronome Settings.....	22
1. Setting the Time Signature (BEAT TYPE) .....	23
2. Setting the Tempo (TEMPO).....	23
3. Selecting the Sound (METRONOME INSTRUMENT).....	23
4. Adjusting the Volume (METRONOME LEVEL) .....	23
5. Adjusting the Stereo Position (METRONOME PAN).....	24
[Making the Settings].....	24

<b>Chapter 4 Setting Common Parameters (Systems) for All Patches ...</b>	<b>25</b>
<b>1 About the Advanced Edit Mode .....</b>	<b>25</b>
1. How to Enter the Advanced Edit Mode .....	25
2. Button Operations in the Advanced Edit Mode .....	26
<b>2 Trigger Parameter Settings .....</b>	<b>27</b>
1. Selecting the Type of Pad (TRIGGER TYPE - tyP) .....	27
2. Adjusting the Sensitivity of a Pad (TRIGGER SENS - SEN) .....	28
3. Preventing Accidental Triggering of a Pad (THRESHOLD - thr) .....	28
4. Curve Settings (CURVE - Cur) .....	28
[Making the Settings].....	29
<b>3 About MIDI .....</b>	<b>30</b>
1. MIDI Connectors .....	30
2. MIDI Channels .....	30
3. MIDI Data Used by the TD-5 .....	31
<b>4 Note Numbers Assigned to Pads .....</b>	<b>33</b>
[Background Instruments].....	34
<b>5 Settings for MIDI-related Functions .....</b>	<b>35</b>
1. Setting the MIDI Channel (Basic Channel).....	35
2. Synchronizing the Metronome with an External MIDI Device (MIDI SYNC Setting) .....	35
3. Switching the Sound of an External MIDI Sound Module (PROGRAM CHANGE SWITCH)...	36
4. Setting FD-7 Control Changes .....	37
5. Saving Data in an External MIDI Device (Bulk Dump/Load) .....	38
6. Editing a Background Instrument (Editing Using a MIDI Keyboard) .....	40
<b>6 Resetting Patch Settings to Their Factory Defaults (Patch Initialize) .....</b>	<b>41</b>
<b>Chapter 5 Here's What Else You Can Do—Some Examples of Usage...</b>	<b>42</b>
<b>1 Having the Metronome play in Sync with the Tempo of         an External Device .....</b>	<b>42</b>
<b>2 Recording and Playing Back a Percussion Performance .....</b>	<b>43</b>
<b>3 Playing the TD-5 with Acoustic Drums .....</b>	<b>44</b>
Setting for Reducing Double -Triggering and Crosstalk (Acoustic Trigger Parameters).....	45
<b>4 Using the TD-5 as a Sound Module .....</b>	<b>48</b>
<b>5 Resetting All Settings to Their Factory Defaults (System Initialize) .....</b>	<b>48</b>
<b>Chapter 6 Reference.....</b>	<b>49</b>
<b>1 If You Think There's a Problem .....</b>	<b>49</b>
<b>2 Error Messages .....</b>	<b>51</b>
<b>3 Basic Operations.....</b>	<b>52</b>
<b>4 Note Number Assignment List         (Trigger Input and Background Instruments).....</b>	<b>54</b>
<b>5 Factory Default Settings .....</b>	<b>55</b>
<b>6 Blank Chart .....</b>	<b>56</b>
<b>7 MIDI Implementation .....</b>	<b>57</b>
<b>8 Specifications .....</b>	<b>67</b>
<b>9 Index .....</b>	<b>68</b>
<b>INSTRUMENT LIST .....</b>	<b>72</b>

# Important Notes

---

Be sure to use only the AC adaptor supplied with the unit. Use of any other AC adaptor could result in damage, malfunction, or electric shock.

## Power Supply

- Before connecting this unit to other devices, turn off the power to all units; this will help prevent damage or malfunction.
- Do not use this unit on the same power circuit with any device that will generate line noise; an electric motor or variable lighting system for example.
- The power requirement for this unit is indicated on its nameplate (rear panel). Ensure that the voltage in your installation meets this requirement.
- Avoid damaging the power cord: do not step on it, place heavy objects on it, etc.
- When disconnecting the AC adaptor from the power outlet, grasp the plug itself; never pull on the cord.
- If the unit is to remain unused for an extended period of time, unplug the power cord.

## Placement

- Do not subject the unit to temperature extremes (e.g., direct sunlight in an enclosed vehicle). Avoid using or storing the unit in dusty or humid areas, or areas that are subject to high levels of vibration.
- Using the unit near power amplifiers (or other equipment containing large power transformers) may induce hum.
- This device may interfere with radio and television reception. Do not use this device in the vicinity of such receivers.
- Do not expose the unit to temperature extremes or install it near devices that radiate heat. Direct sunlight in an enclosed vehicle can deform or discolor the unit.

## Maintenance

- For everyday cleaning wipe the unit with a soft, dry cloth or one that has been slightly dampened with water. To remove stubborn dirt, use a mild, non-abrasive detergent. Afterwards, be sure to wipe the unit thoroughly with a soft, dry cloth.
- Never use benzene, thinners, alcohol or solvents of any kind, to avoid the possibility of discoloration and/or deformation.

---

## Additional Precautions

- Protect the unit from strong impact.
- Do not allow objects or liquids of any kind to penetrate the unit. In the event of such an occurrence, discontinue use immediately. Contact qualified service personnel as soon as possible.
- Never strike or apply strong pressure to the display.
- Should a malfunction occur, or if you suspect there is a problem, discontinue use immediately. Contact qualified service personnel as soon as possible.
- To avoid the risk of electric shock, do not open the unit or its AC adaptor.

## Memory Backup

- This unit contains a battery which powers the unit's memory circuits while the main (AC) power is off. The expected life of this battery is 5 years or more. However, to avoid the untimely loss of memory data, it is strongly recommended that you change the battery every 5 years. Please be aware that the actual life of the battery will depend upon the physical environment — especially the temperature — in which the unit is used. When it is time to change the battery, consult with qualified service personnel.
- When the battery becomes weak the following message will appear in the display. Please change the battery as soon as possible to avoid the loss of memory data.

bAtteRy Lo

- Please be aware that the contents of memory may at times be lost; when the unit is sent for repairs or when by some chance a malfunction has occurred. Important data should be stored in another MIDI device (e.g., a sequencer), or written down on paper (if possible). During repairs, due care is taken to avoid the loss of data. However, in certain cases (such as when circuitry related to memory itself is out of order), we regret that it may not be possible to restore the data.

# Panel Descriptions

---

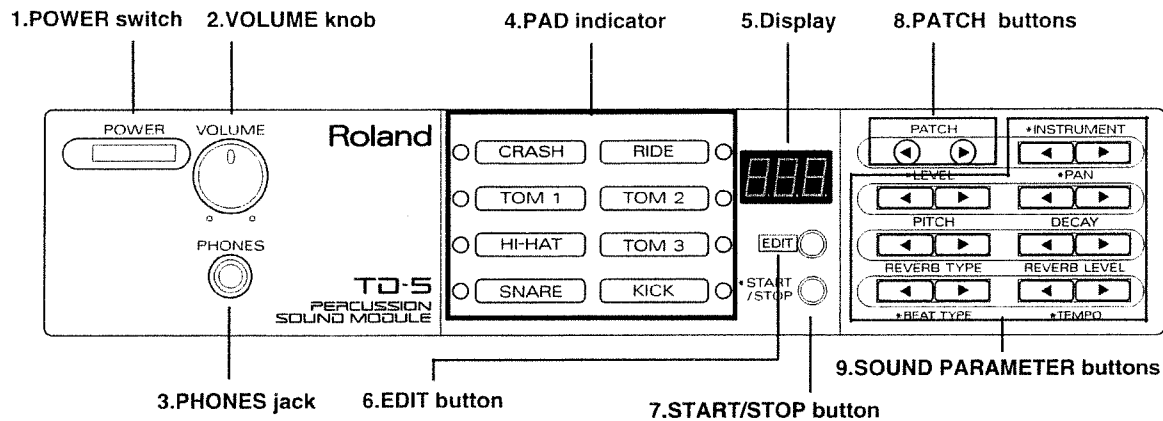

## Front Panel

### 1. POWER switch

This switch turns the unit on or off (p. 12).

### 2. VOLUME knob

This knob adjusts the volume of the OUTPUT jacks and PHONES jack.

### 3. PHONES jack

A pair of stereo headphones can be connected to this jack. The OUTPUT jacks are still active even when headphones are connected.

### 4. PAD indicator

The PAD indicator lights up to indicate the Pad currently being played or edited.

### 5. Display

This display indicates the Patch number or the values of parameters.

### 6. EDIT button

Each press of this button toggles the unit between the Play mode and the Edit mode (p. 16). The TD-5 is in the Play mode when the button is not lighted, and in the Edit mode when it is lit. What is shown in the display flashes on and off while in the Edit mode. Also, by continuing to press the button for a few seconds, you are taken to the Advanced Edit mode (p. 25). In this mode the button will also be lit, but the display will flash at a faster rate than for the Edit mode.

### 7. START/STOP button

Press to start or stop the metronome (p. 22) when in the Play mode. In the Edit mode, it functions as a preview button, allowing you to check the sound (except during Patch Copy). When the [START/STOP] button flashes, it is the button you need to press to execute the procedure during Patch Copy (p. 21), Initialize (p. 41, 48), and Bulk Dump (p. 38) operations.

---

## 8. PATCH buttons

These buttons are used to select Patches (p. 14).

## 9. SOUND PARAMETER buttons

In the Edit mode, they are used to change the values of the sound parameters (p. 18). When the metronome is ON in the Play mode, the [SOUND PARAMETER] buttons indicated with asterisks can be used to set parameters for the metronome (p. 22). In the Advanced Edit mode, these buttons serve functions that differ from their button names (p. 26).

- **INSTRUMENT buttons (\*)**

These buttons select the Instrument when in the Edit mode.

When the metronome has been started in the Play mode, they can be used to select the metronome sound.

- **LEVEL buttons (\*)**

These buttons are used to set the volume of the Instrument when in the Edit mode.

When the metronome has been started in the Play mode, these can be used to set the metronome level.

- **PAN buttons (\*)**

These buttons are used to set the stereo position of the Instrument when in the Edit mode.

When the metronome has been started in the Play mode, these can be used to set the stereo position of the metronome.

- **PITCH buttons**

These buttons are used to adjust the pitch of the Instrument when in the Edit mode.

- **DECAY buttons**

These buttons are used to adjust the decay of the Instrument when in the Edit mode.

- **REVERB TYPE buttons (\* BEAT TYPE)**

These buttons select the type of reverb when in the Edit mode.

When the metronome has been started in the Play mode, these can be used to select the beat type of the metronome.

- **REVERB LEVEL buttons (\* TEMPO)**

These buttons are used to adjust the send level of reverb when in the Edit mode.

When the metronome has been started in the Play mode, these can be used to set the tempo of the metronome.

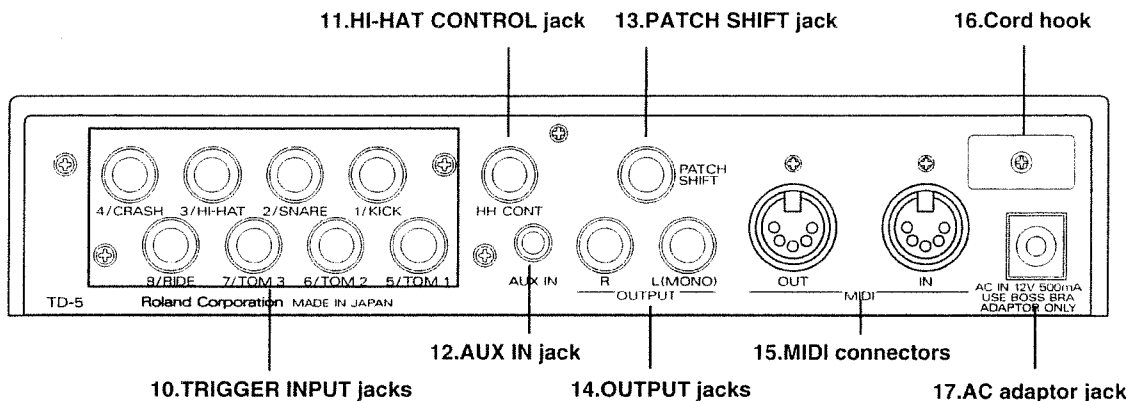

## Rear Panel

### 10. TRIGGER INPUT jacks

These jacks are for receiving trigger signals from up to eight Pads. A choice of instrument sounds is assigned to the jacks when the TD-5 is shipped, but you can change these as you please. Since they are stereo jacks, you can use techniques such as rim shots and cymbal chokes when you have PD-7 or PD-9 Pads connected. A monaural cable should be used when connecting Pads other than the PD-7 or PD-9. One or more drum triggers can also be connected to these jacks (p. 44).

### 11. HI-HAT CONTROL jack

This jack accepts control signals from a Hi-hat Control Pedal (FD-7; sold separately) (p. 15).

### 12. AUX IN jack

Used to mix sounds from a headphone stereo or other audio device, with output made through the PHONES jack. There is no output to the OUTPUT jacks.

### 13. PATCH SHIFT jack

A Foot Switch (available separately) can be connected here, allowing you to change Patches remotely (p. 14).

### 14. OUTPUT jacks

Provide output of the sound. Connect only to the L (MONO) jack when monaural output is desired.

### 15. MIDI connectors

External MIDI devices are connected here (p. 30).

### 16. Cord hook

Wrap the AC adapter cable around this hook to prevent the plug from being pulled out accidentally.

### 17. AC adaptor jack

The AC adaptor included with the TD-5 is connected here.

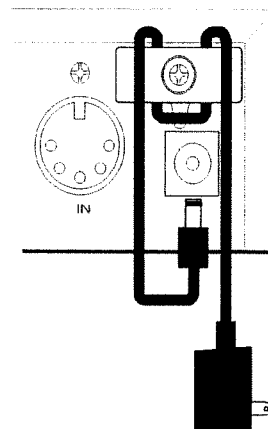



# About External Drum Pads and Kick Trigger Units

---

For truly expressive play, we recommend connecting Roland's special Pads (the PD-7, PD-9, or PD-5; sold separately) or Kick Trigger Units (KD-7 or KD-5; sold separately).

The eight TRIGGER INPUT jacks are all stereo jacks. This means that when you connect the PD-7 or PD-9, the TD-5 processes both the signal produced when the head of the Pad is struck, as well as the signal for when the rim is struck for a rim shot. Set the Polarity Switch for the special Pad to the "Roland" ("R") side.

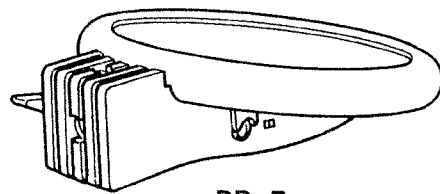

PD -7

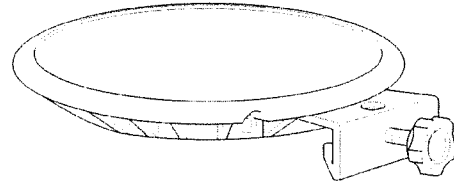

PD -5

	Size	Rim Sensor
PD-5	222mm	No
PD-7	192mm	Yes
PD-9	254mm	Yes

## Recommended Pads for the TD-5 and Their Specifications

Pads other than Roland pads can also be used.

You can also use Drum Trigger to play TD-5 sounds from your acoustic drums.

The TD-5 can be triggered by sound signals recorded on tape. This means that you can replace sounds recorded on separate tracks of a multi-track recorder with the TD-5's sound.

Use the Trigger Parameter (p. 28) to adjust the input sensitivity of a Pad or Drum Trigger.

# Attaching the TD-5 to a Drum Stand

When attaching the TD-5 to the stand holder of a Drum Stand (MDS-7; sold separately), be sure to use the screws provided (four 8-mm M5 screws). The following figure shows how to make the attachment.

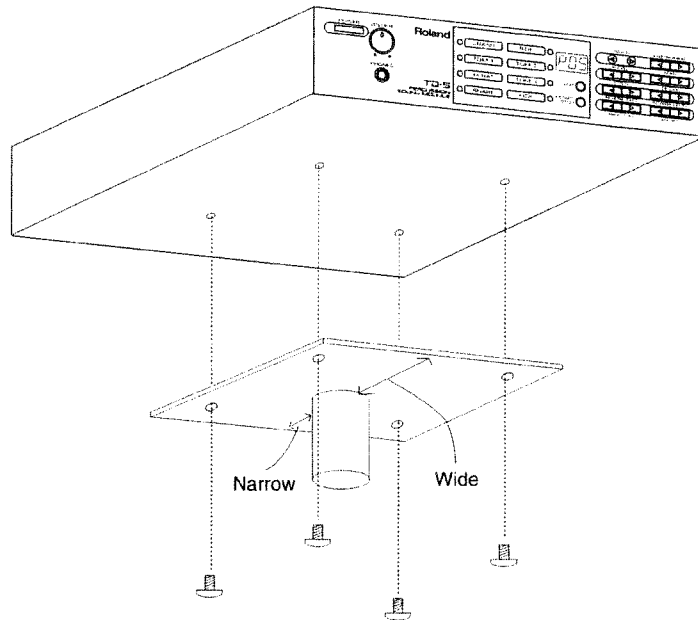

***\*Inadvertently using longer screws may result in damage to the TD-5.***

If you are not going to use the optional rack mount adaptor (RAD-50), be sure to affix the supplied rubber feet onto the bottom of the unit as shown below.

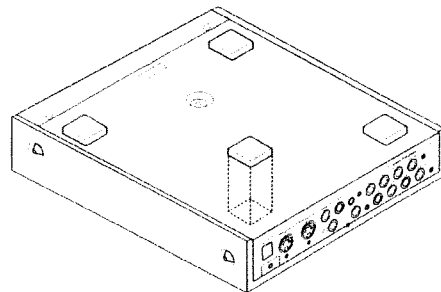

When mounting the unit using the rack mount adaptor, make sure to use the supplied screws (two M3 x 6 mm).

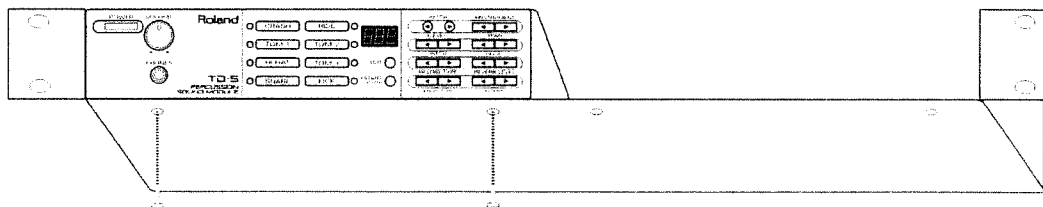

# Chapter 1 Playing the TD-5

## 1 Connection to Audio Equipment

Before making any connections, be sure that the power to the TD-5 and all other devices to be connected is turned off. If the power is on while you make the connections, you may damage your speakers.

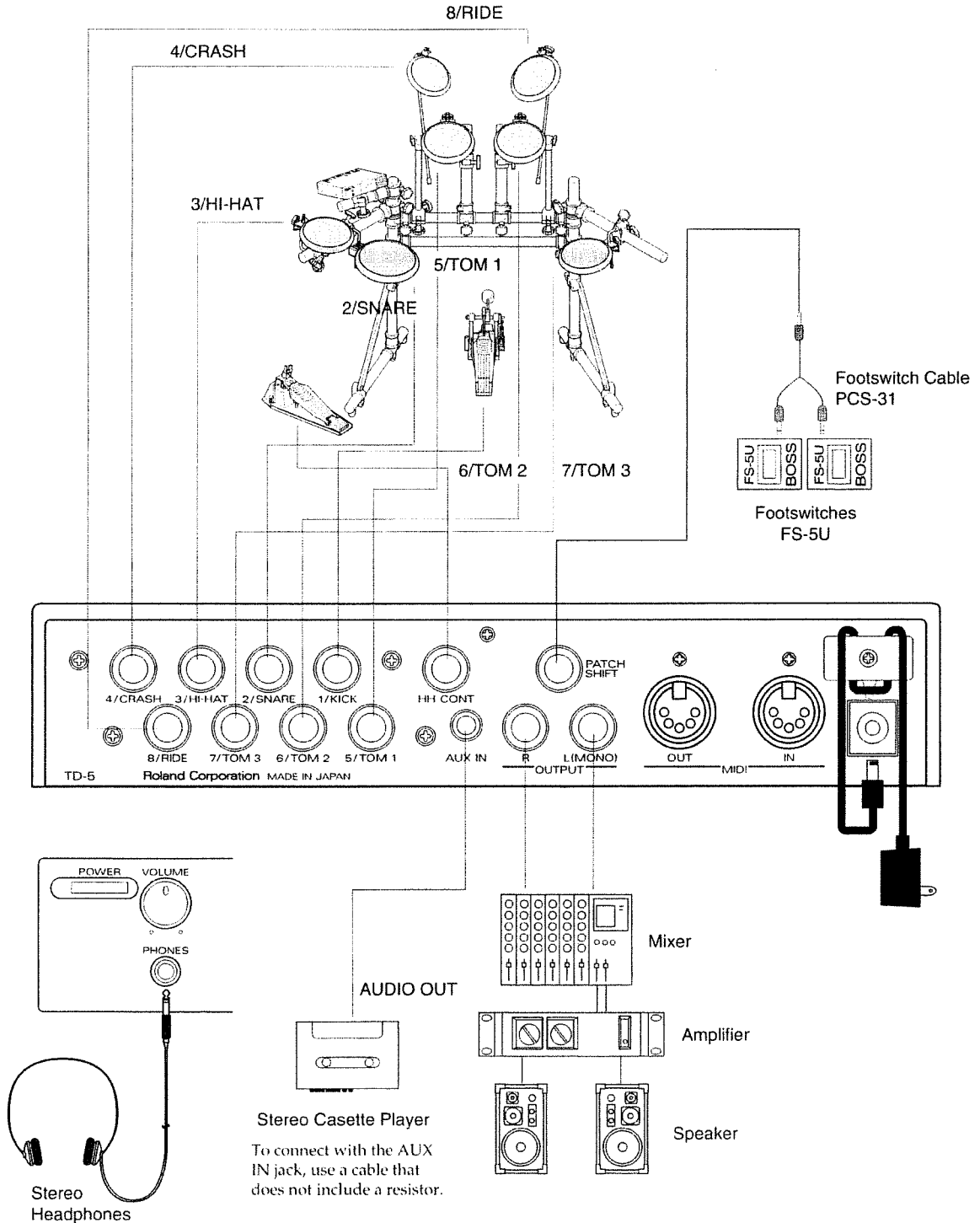

---

---

## 2 Turning the Power On and Off

**Step 1** Check that connections with all other devices are correct, and make sure that everything is off. Then press the POWER switch to turn on the TD-5.

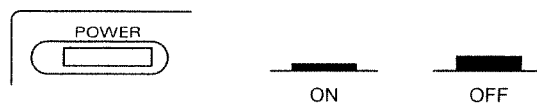

This display indicates the Patch number.



**! After you turn on the power, don't strike the Pads or press the Hi-Hat Control Pedals until the Patch number is displayed.**

**Step 2** Turn on the power to any other devices that are connected.

When powering down, first switch off the other devices, then turn off the TD-5.

## 3 Adjusting the Volume

Strike a Pad to play the sound assigned to it.

Turn the VOLUME knob clockwise for a louder sound and counterclockwise for lower volume.

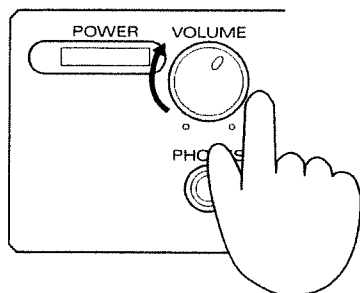

**! Be sure to watch the output level when the TD-5 is connected directly to an audio set. Excessive volume can damage your speakers or other audio equipment.**

**\* When the TD-5 has been set so that the metronome can be heard only through the headphones (METRONOME PAN : Pho, p. 24), the VOLUME knob cannot be used to adjust the sound level of the metronome. Instead, make the setting with METRONOME LEVEL (p. 23).**

---

---

## 4 Playing the Pads

When you strike a Pad, the PAD indicator flashes momentarily.

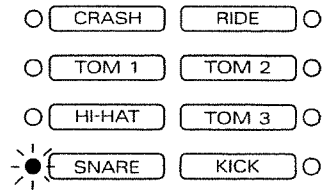

**When the Snare Pad is played**

When using a PD-7 or PD-9 Pad, you can play separate instruments with a Normal shot and a Rim shot.

### Rim Shot (for PD-7 or PD-9)

When playing a rim shot, be sure to strike the center and rim of the Pad simultaneously. When performing a rim shot, the instrument assigned to the rim of the Pad is sounded. This sound may not be played correctly if you strike only the rim.

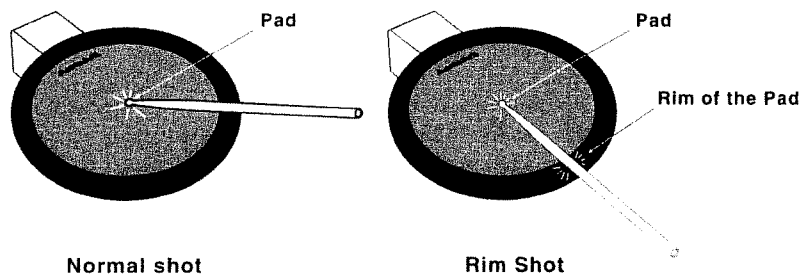

**Normal shot: Only the center of the Pad is struck (head shot)**

**Rim shot: The center and rim are struck simultaneously, just as you would with an acoustic drum.**

### Choke Effect (for PD-7 or PD-9)

You can mute the sound of a cymbal by playing the cymbal and then immediately grasping its edge. This technique is called the choke effect. With the TD-5, if immediately after striking the Pad you grab hold of the rim, the instrument currently being played will be muted.

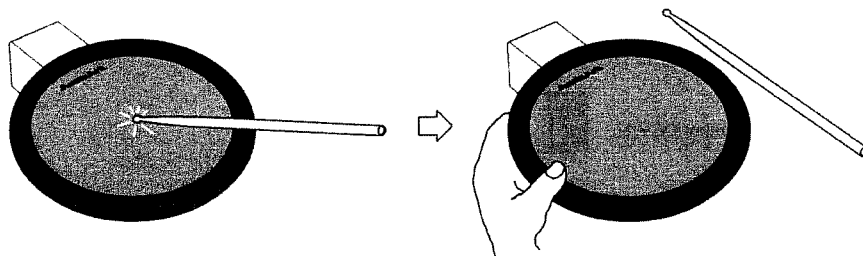

\* Rim shot and "choke" styles of playing are available only when using the PD-7 or PD-9. They are not available when using the PD-5.

---

---

## 5 Changing the Sound (Changing the Patch [Drum Set])

On the TD-5, a single drum set (the combination of sounds assigned to the various Pads) is called a Patch. The TD-5 can store up to 32 different Patches in memory. This means you can play 32 different drum sets on a single TD-5.

When shipped from the factory, a variety of drum set sounds are preset to the Patches. Try changing Patches and listening to the many different drum set sounds.

**Step 1** First, make sure that [EDIT] is not lit up.

*\* If [EDIT] is lit, press [EDIT] to extinguish the button light. This puts you back in the Play mode ("Play Mode and Edit Mode," p. 16).*

**Step 2** Use the PATCH [◀] and [▶] buttons to select the Patch (1 to 32).

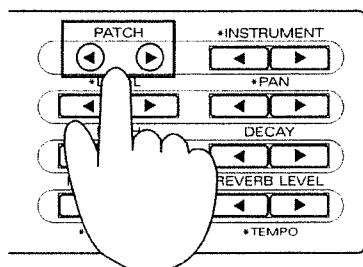

*\* You can also change just a single Pad sound from among the many Pad sounds in a drum set. For details on how to do this, see "Changing the Instruments Assigned to a Pad" (p. 17).*

### Changing Patches with Foot Switches

When you use a special cable (PCS-31; sold separately) to connect two Foot Switches (FS-5U; sold separately) to the PATCH SHIFT jack, you can switch Patches by pressing the pedals with your foot.

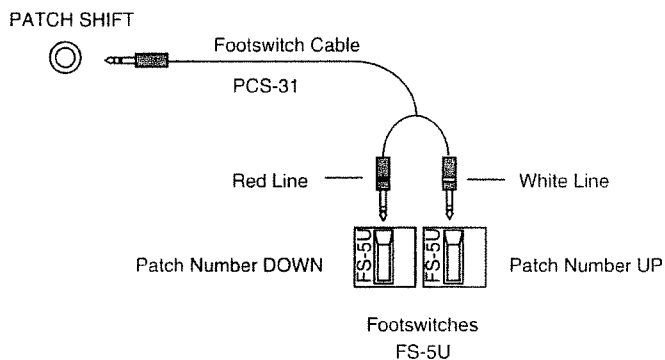

Pressing the Foot Switch connected to the plug with the white line increases the Patch number, and pressing the Foot Switch connected to the plug with the red line decreases the Patch number.

When using a Foot Switch (DP-2), you can only increase the Patch number.

---

---

## 6 Using a Hi-hat Control Pedal

### Operation of a Hi-hat Control Pedal

When a Hi-hat Instrument (H01 or higher) has been assigned to a Pad connected to the INPUT 3/HI-HAT jack, you can use a Hi-hat Control Pedal to vary the Hi-hat sound continuously from fully open to fully closed. You can even use the Pedal Closed Hi-hat and Pedal Open Hi-hat \*1. The Hi-hat control pedal can also be used to change the sound of a number of instruments other than the Hi-hat (p. 72).

**\* 1 You will not be able to obtain any sound with a pedal - only close (open) of the Hi-hat if you assign Hi-hat (HH) or Pedal Inst (PI) to the rim ("HH", "PI" see p. 72).**

Connect a special Hi-hat Control Pedal (FD-7; sold separately) to the HI-HAT CONTROL jack.

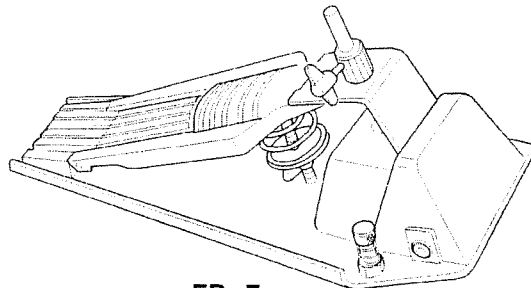

FD -7

Open Hi-hat:	Hi-hat struck without depressing pedal.
Closed Hi-hat:	Hi-hat struck while pedal is depressed.
Pedal Closed Hi-hat:	Pedal is depressed.
Pedal Open Hi-hat:	Pedal is released immediately after depressing it.

The DP-2 Foot Switch can also be used, although this Foot Switch only allows you to switch between open and closed.

### Precautions When Using a Hi-hat Control Pedal

Simply connecting an FD-7 to the TD-5 is not enough to make it function correctly. The TD-5 needs to be made aware of the FD-7 so that it can automatically make the appropriate settings. The same holds true when the DP-2 is used as a Hi-hat Control Pedal.

**Step 1 Connect the Hi-hat Control Pedal to the HI-HAT CONTROL jack.**

**Step 2 Make sure that the pedal is open.**

***! If the pedal is depressed, the settings will not be made correctly.***

**Step 3 Turn the power off, then on again.**

Don't depress the pedal until the Patch number appears in the display.

This procedure makes it possible to use the Hi-hat Control Pedal with the appropriate settings.

***! Operating the Hi-hat Control Pedal alters the sound only when the Hi-hat (or other acceptable instrument, see INSTRUMENT LIST p. 72) has been assigned to the Pad connected to the INPUT 3/HI-HAT jack. The Hi-hat Control Pedal has no effect on any of these instruments when they are assigned to a Pad that is connected to any of the other TRIGGER INPUT jacks.***

# Chapter 2 Changing the Sound Played by a Pad (Edit Mode)

## Play Mode and Edit Mode

The Play mode is used to play sound by striking the Pads, and also to select Patches. This mode is also used for sounding the metronome.

The Edit mode is used to change Patch settings and to copy Patches. The process of changing settings is called "editing."

Each press of [EDIT] toggles the unit between the Play mode and the Edit mode.

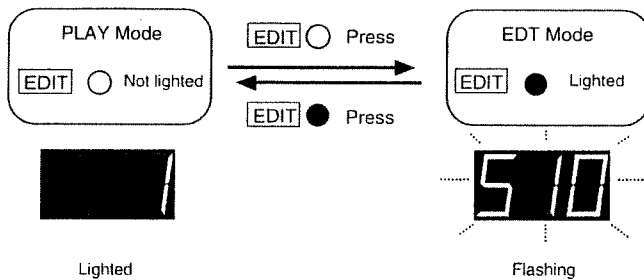

*\* In addition to the Play and Edit modes, there is also an Advanced Edit mode (p. 25).*

## Patches and Sound Parameters

The percussion sound played with a Pad, together with the tone settings for the sound are called "sound parameters." Independent sound parameters for up to eight Pads can be stored in a single Patch. When using PD-7s or PD-9s as the Pads, sound parameters can be set independently for eight inputs, for both centers and rims, allowing a total of 16 instruments to be played from pads with a single Patch.

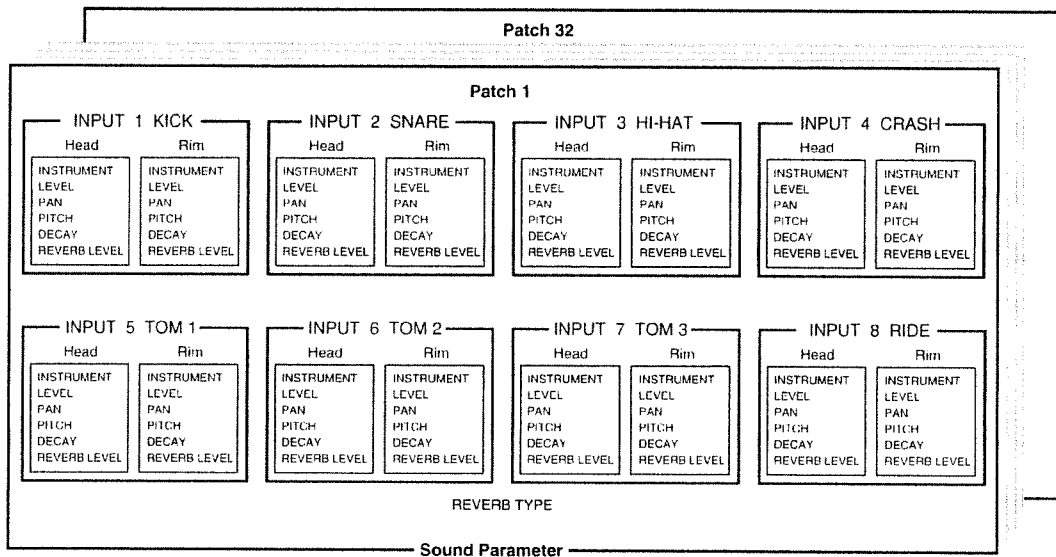

*\* Settings for the rim can be made only when a PD-7 or PD-9 is connected.*

*\* REVERB TYPE settings cannot be made for individual Pads.*



---

---

## 1 Changing the Instruments Assigned to a Pad

The percussion instrument sounds played with the Pads of the TD-5 are called "Instruments." (INSTRUMENT LIST, p. 72)

Each Instrument belongs to one of the following groups:

### Instrument Groups

Kick	K01 and after
Snare Drum	S01 and after
Tom Tom	t01 and after
Hi-hat	H01 and after
Cymbal	C01 and after
Percussion	P01 and after
Effect	E01 and after



Instrument Group (kick)

**Step 1** In the Play mode, press the PATCH [◀] or [▶] button to select the Patch to edit.

**Step 2** Press [EDIT] to enter the Edit mode (the button should be lighted).

**Step 3** Strike the Pad you wish to edit.

If you are using a PD-7 or PD-9, be careful to strike the center and rim of the Pad separately.

The PAD indicator lights up when you strike the center of the Pad and flashes when you strike the rim.

**Step 4** Press the INSTRUMENT [◀] or [▶] button to select the Instrument.

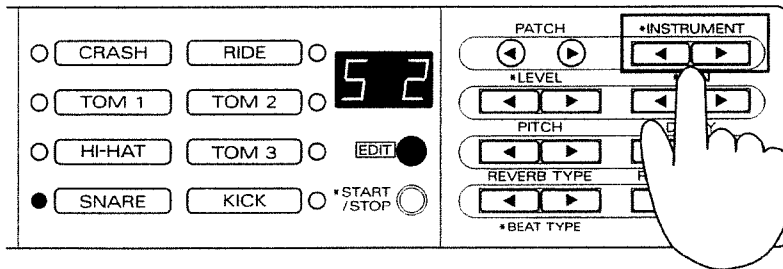

This shows the Snare Drum Instrument being edited.

\* Pressing the INSTRUMENT [◀] or [▶] button while another sound parameter setting is displayed causes the current Instrument to be displayed. The Instrument will change the next time you press the button. (This works the same way for other sound parameters, too.)

\* You can change the value more rapidly by holding down the [◀] or [▶] button. Holding down [▶] (or [◀]) and pressing [▶] (or [◀]) advances you to the next Instrument group.

\* Press [START/STOP] to play the sound of the currently selected Pad (Preview function). This is a handy way of checking the sound of a Pad without actually striking it. (This function only works in the Edit mode.)

If you wish to change the settings for another Instrument, repeat Steps 3 and 4.

**Step 5** Press [EDIT] to return to the Play mode (the button light goes out).

\* A Hi-hat sound can be varied by operating a Hi-hat Control Pedal when a Hi-hat Instrument (H01 or higher) has been selected for the Pad connected to the INPUT 3/HI-HAT jack. Operating the Hi-hat control pedal also alters the sound of a number of instruments other than the Hi-hat (INSTRUMENT LIST, p. 72).

---

---

## 2 Changing the Way an Instrument Sound

The following Parameters can be set.

### 1. Adjusting the Volume (LEVEL)

This parameter determines the volume of the Instrument (0 to 15). At a setting of 0, no sound will be produced.

### 2. Adjusting the Stereo Position (PAN)

This parameter determines the stereo position of the Instrument (L7 to Ctr to R7/rnd/ALt). A higher L value moves the sound farther to the left, and a higher R value moves it to the right. A setting of Ctr gives a centered sound. At the "rnd" setting, it will change randomly each time the pad is struck. At "ALt," the sound shifts between left and right each time the pad is struck.

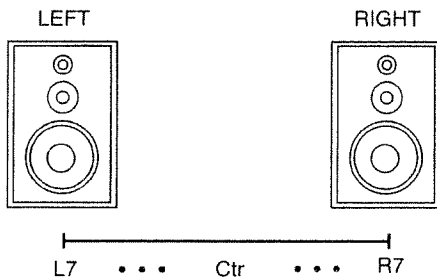

This parameter is effective only when connected to a stereo audio system.

### 3. Adjusting the Pitch (PITCH)

This parameter determines the pitch of the Instrument's sound (-95 to 95). Increasing the value by 10 raises the pitch by a half-step.

*\* Depending on the Instrument, it may not be possible to raise the pitch beyond a certain level.*

### 4. Adjusting the Decay Time (DECAY)

This parameter determines the decay time (the time it takes for the sound to die away) of the Instrument (-31 to 31).

Higher settings result in a longer decay time.

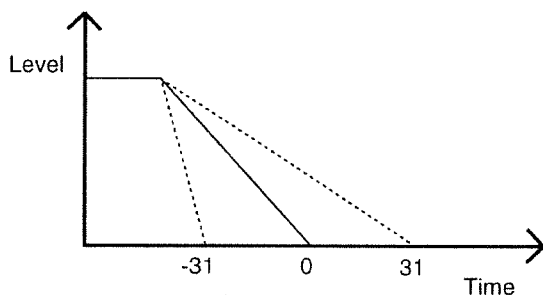

*\* With certain instruments, you can reach a point where no further change in the decay is possible even when the value is increased.*

---

---

## 5. Selecting a Reverb Type (REVERB TYPE)

The desired type of reverb or delay can be selected from the following.

A Reverb type cannot be set for every Pad. The desired type can be selected for each Patch.

oFF	Reverb OFF
rM1	Room reverb (Bright)
rM2	Room reverb (Dark)
HL1	Hall reverb (Bright)
HL2	Hall reverb (Dark)
PLt	Plate reverb
trE	Reverb that shifts from side to side (tremolo reverb)
dL1-9	Delay without feedback
Fb1-5	Panning delay with feedback

*\* As the number increases, the delay time gets longer for dL1 to 9 and Fb1 to 5.*

## 6. Adjusting the Reverb Depth (REVERB LEVEL)

This parameter determines the send level of the reverb (0 to 15). Higher settings result in reverbs of greater depth. There is no reverb when set to 0.

---

## [Making the Settings]

**Step 1** Press the PATCH [◀] or [▶] button to select the Patch you wish to change.

**Step 2** Press [EDIT] to enter the Edit mode (the button should be lighted).

**Step 3** Strike the Pad you wish to edit.

If you are using a PD-7 or PD-9, be careful to strike the center and rim of the Pad separately.

*\* The PAD indicator lights up when you strike the center of the Pad and flashes when you strike the rim.*

**Step 4** Press the SOUND PARAMETER [◀] or [▶] button to select the Instrument.

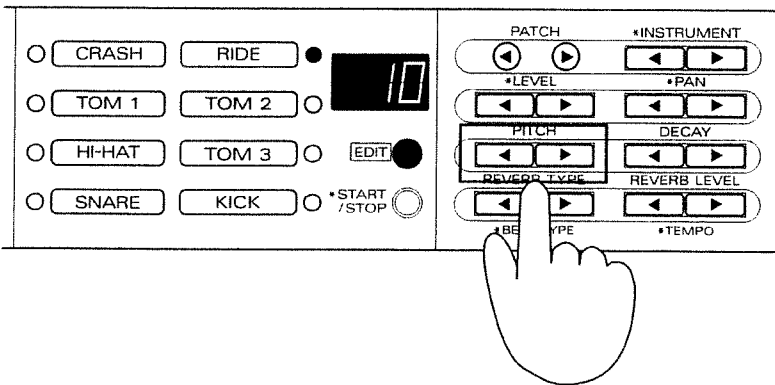

The illustration shows the pitch of the Ride Cymbal being edited.

*\* Pressing the PITCH [◀] or [▶] button while another sound parameter setting is displayed causes the current Pitch to be displayed. The Pitch will change the next time you press the button. (This works the same way for other sound parameters, too.)*

*\* You can change the value rapidly by holding down the [◀] or [▶] button. Holding down [▶] (or [◀]) and pressing [▶] (or [◀]) will change the value even more rapidly.*

*\* Pressing [START/STOP] plays the sound of the currently selected Pad (Preview function). This is a handy way to check the sound of a Pad without actually striking it. (This function only works in the Edit mode.)*

If you wish to change the settings for another Pad or another sound parameter, repeat Steps 3 and 4.

**Step 5** After you have made the settings for the desired sound, press [EDIT] to extinguish the button light and return to the Play mode.

The sound parameters are set for each Pad.

If you select a different Instrument after changing the sound parameters, the parameters are carried over and applied to the newly selected Instrument.

*\* The Open, Closed, and closed play sounds cannot be edited individually.*

*\* While altering the Reverb Type, the indicators for all the Pads will light. This is because the setting for Reverb Type is common to all the Pads.*

---

## If you just want to display the sound parameter settings without making any changes

First, enter the Play mode. Strike the Pad, then press either the [◀] or [▶] button for the sound parameter that you want to check. The display shows the current setting for a few seconds, then reverts to the Patch number. This procedure will not change the settings in any way.

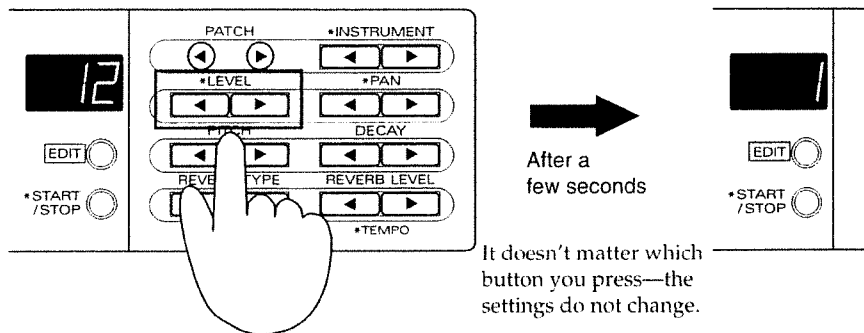

If you press [EDIT] before returning to the Patch display, you are taken to the mode where you can edit that parameter.

### 3 Copying a Patch (Drum Set)

You can copy Patch settings (the settings for all eight Pads) to another Patch. This feature is used when creating a Patch that is only slightly different from an existing one, or when changing the order of the Patches.

**Step 1** While in the Play mode, press the PATCH [◀] or [▶] button to choose the Patch to be copied (the copy-source Patch).

**Step 2** Press [EDIT] to enter the Edit mode (the button should be lighted).

**Step 3** Press the PATCH [◀] or [▶] button to choose the copy-destination Patch.

This makes the [START/STOP] button begin to flash.

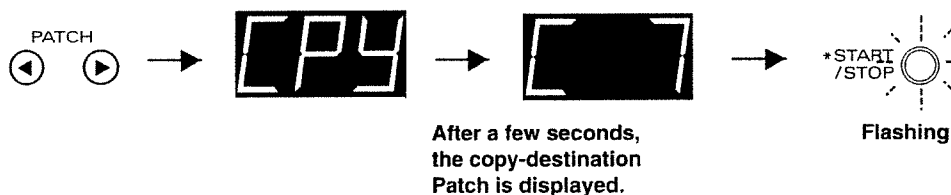

\* To quit without copying, press [EDIT].

**Step 4** Press the flashing [START/STOP] button to perform copying.



When copying is finished, the TD-5 automatically returns to the Play mode (and the [EDIT] button light goes out).

# Chapter 3 Using the Metronome

---

The metronome can be used when practicing to maintain an unchanging beat and tempo.

## 1 Starting and Stopping the Metronome

**Step 1** While in the Play mode, press the [START/STOP] button to start the metronome.

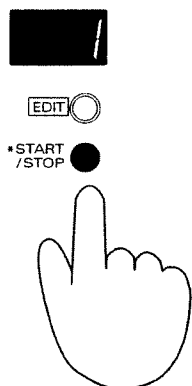

The [START/STOP] button will flash in time with it.

*\* If "Sync" appears in the display, you will need to switch the setting for MIDI SYNC to "OFF" before the metronome can be started (MIDI SYNC setting: p. 35).*

**Step 2** Press the [START/STOP] button again to stop the metronome and extinguish the button light.

*\* When starting or stopping the metronome, you can also start or stop a sequencer connected to the MIDI OUT jack. Set the sync clock for the sequencer so that it is synchronized with an external MIDI device.*

*\* You can also have the metronome sound in sync with the tempo being used by an external unit (p. 42).*

## 2 Metronome Settings

You can make changes in how the metronome plays, its volume level, and other aspects. Settings for the metronome are made after the metronome has been started.

After the metronome has been started, the SOUND PARAMETER buttons marked with a blue asterisk ("\*") are used to set the metronome's parameters. The settings you make for the metronome parameters are used in common by all Patches.

Parameters indicated by a blue asterisk can be set.

---

## 1. Setting the Time Signature (BEAT TYPE)

This setting is where you select a time signature for the metronome (1-4 through 7-4, 2-8, 4-8, 6-8, 8-8, tr1, tr2, tr3, tr4). Not only quarter notes, but eighth notes and triplets can also be sounded by the metronome.

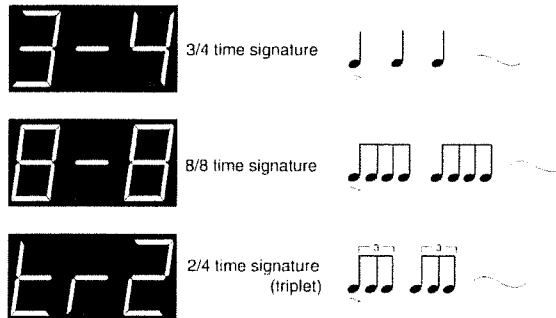

\* "tr" stands for "triplet."

## 2. Setting the Tempo (TEMPO)

This parameter determines the tempo of the metronome ( $\text{♩} = 40$  to 250). When the display indicates "Sync," it means that the MIDI sync setting has been turned on (p. 35). This means the tempo of the metronome has been placed in sync with an external MIDI device, so no tempo setting can be made. Set the tempo after first turning MIDI SYNC to "off".

## 3. Selecting the Sound (METRONOME INSTRUMENT)

You can choose from the following 16 sounds for the metronome:

VcE	VOICE (girlfriend mode)	Mrc	MARACAS
CLi	CLICK	Cab	CABASA
CLa	CLAVES	Cui	CUICA
bLK	WOOD BLOCK	AGG	AGOGO
tri	TRIANGLE	tMb	TAMBOURINE
Cow	COWBELL	SnP	SNAPS
CnG	CONGA	909	909 SNARE
tLK	TALKING DRUM	808	808 COWBELL

\* When set to "VcE" you hear the voice of a person counting.

## 4. Adjusting the Volume (METRONOME LEVEL)

This parameter determines the volume of the metronome (0 to 15).

Note that if METRONOME PAN is set to "Pho," you will not be able to use the volume knob to adjust the volume. Use the "METRONOME LEVEL" setting instead.

## 5. Adjusting the Stereo Position (METRONOME PAN)

This parameter determines the stereo position of the metronome as heard from the left and right speakers (L7 to Ctr to R7/Pho). When set to “Pho,” the metronome sound is output only through the PHONES jack, with no output from the OUTPUT jacks. The VOLUME knob cannot be used to adjust the sound level of the metronome when in this state, so the volume setting must be made with the METRONOME LEVEL parameter.

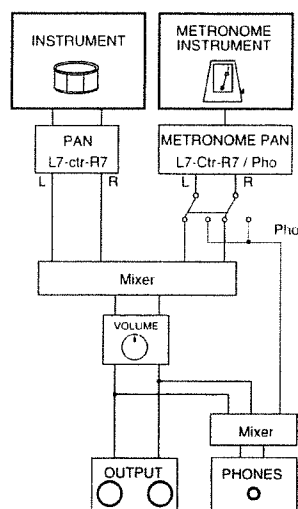

### [Making the Settings]

**Step 1** While in the Play mode, press the [START/STOP] button to start the metronome. The button begins to flash.

**Step 2** Press the [◀] or [▶] button for the parameter you wish to set, thereby changing the value.

*\* You will still be able to change Patches even after the metronome has been started.*

The correspondences between the parameters and the buttons are as shown below.

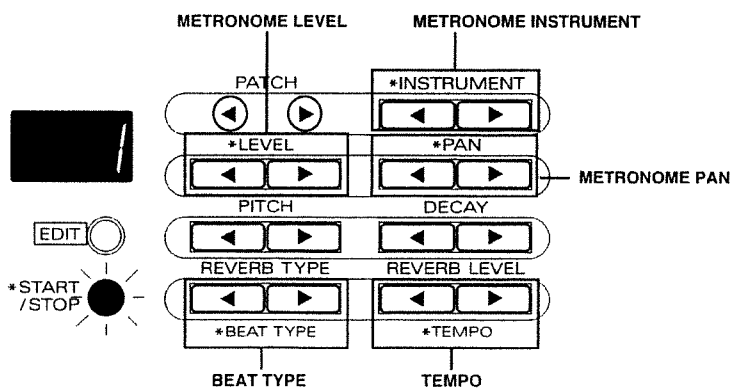

*\* You can change the value rapidly by holding down the [▶] (or [◀]) button and pressing the [▶] (or [◀]) button.*

**Step 3** Press the [START/STOP] button to stop the metronome.



# Chapter 4 Setting Common (System) Parameters for All Patches

## 1 About the Advanced Edit Mode

In addition to the Play mode and Edit mode already described, the TD-5 also has an Advanced Edit mode.

Whereas the Edit mode lets you edit Patches, the Advanced Edit mode lets you determine parameters which are shared by all Patches (trigger parameters).

*\* Trigger parameters can be set for each Pad.*

The Advanced Edit mode is also used to carry out operations like the ones listed below. For details, see p. 35.

- Setting send/receive switches for MIDI data
- Saving TD-5 data onto an external MIDI device (Bulk Dump)
- Returning Patch settings and other values to their factory defaults (Patch Initialize)

### 1. How to Enter the Advanced Edit Mode

Hold down the [EDIT] button for a few seconds until you notice that what is shown in the display is flashing faster (the Edit button lights). This means you are in the Advanced Edit mode.

*\* The Advanced Edit mode is unavailable if the metronome is turned on.*

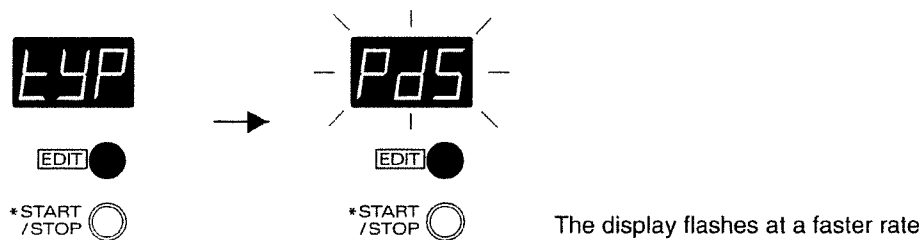

The display flashes faster in the Advanced Edit mode than in the Edit mode.

To leave the Advanced Edit mode, press the [EDIT] button again. This also makes the button go out.

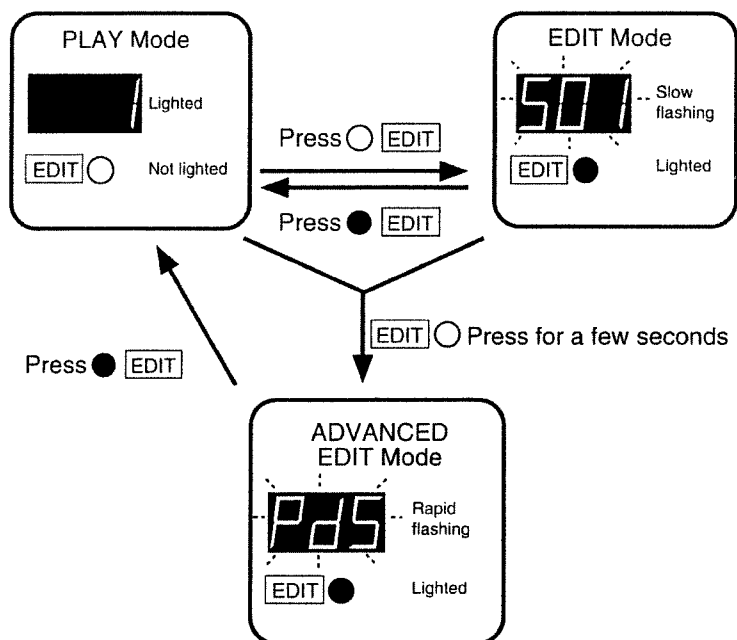

## 2. Button Operations in the Advanced Edit Mode

In the Advanced Edit mode, the functions obtained with the PATCH and SOUND PARAMETER buttons are not specifically labeled on the front panel — unlike the Play and Edit modes. The PATCH [◀] and [▶] buttons are used to change the value of a parameter, and the SOUND PARAMETER buttons are used to select individual parameters. Pressing a SOUND PARAMETER button when in the Advanced Edit mode causes the three-letter name of the parameter to appear in the display for several seconds, followed by a display of the parameter value.

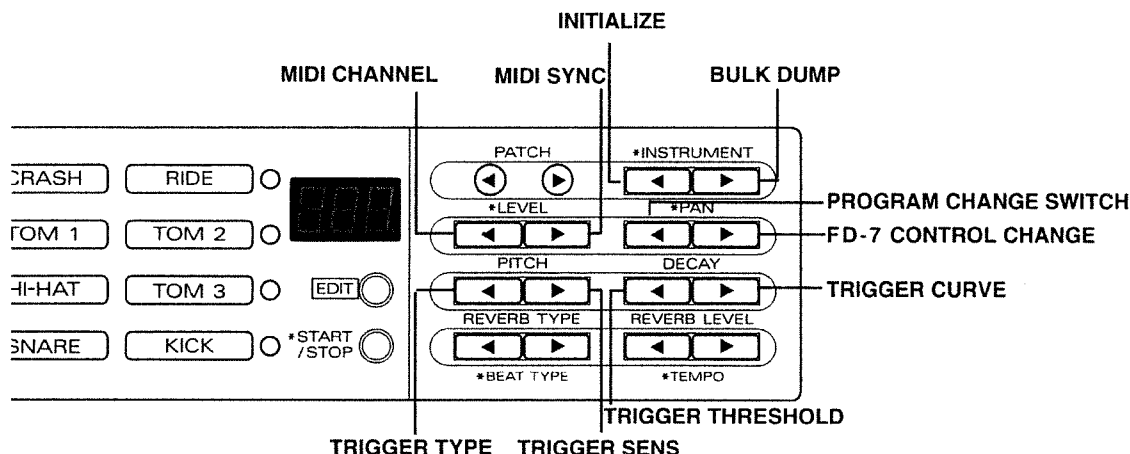

---

---

## 2 Trigger Parameter Settings

The trigger inputs on the TD-5 allow for the connection and play of a wide variety of Pads and pickups for acoustic drums (Drum Trigger). However, since trigger signals differ depending on the type of Pad or Drum Trigger, the trigger parameters need to be set to accommodate it.

Trigger parameters can be set independently for the eight Pads, but they cannot be set for each Patch.

*\* The settings for the trigger parameters will apply to both the head and rim (when using the PD-7 or PD-9).*

*\* The factory default settings for the trigger parameters are geared toward the TD-5 KIT (the PD-5 and KD-5). If you are using the TD-5 with this set-up, there is no need to change the factory settings for the trigger parameters.*

### 1. Selecting the Type of Pad (TRIGGER TYPE - tyP)

You need to specify the types of Pads you are connecting to the TRIGGER INPUTS. By selecting the appropriate TRIGGER TYPE, you assure that the TD-5 will carry out its internal processing in a way that better fits the characteristics of the Pads, and that the degree of force you use will be accurately translated in terms of sound. (The sensitivity of the Pads also should be set using the TRIGGER SENS setting.) When set correctly, the unit also will be able to more reliably prevent errors associated with a certain type of Pad (such as double-triggering), and prevent the false triggering that can occur as a result of vibrations picked up from adjacent Pads (crosstalk).

#### Trigger Types for Pads

Pd5	For the PD-5
Pd7	For the PD-7, PD-31 and PD-21 (standard trigger type)
Pd9	For the PD-9; Pads resistant to crosstalk
P 1	For Pads which output trigger signals with waveforms that are somewhat slow in rising. This setting lengthens the scan time (compared with Pd7) so the unit is better able to correctly read the Pad's output.
P 2	This setting increases the scan time further than "P 1"
Kd5	For the KD-5 and KD-7 (standard Kick Pad trigger type)
K 1	For the PD-11; scan time somewhat longer than "Kd5" (for Kick Pads)
K 2	Scan time increased further than "K 1" (for Kick Pads)

*\* When using Pads from other manufacturers, first try the "Pd7" setting ("Kd5" for Kick Pads). If this doesn't provide correct expression of variations in striking force, try "P 1" or "P 2" ("K 1" or "K 2" for Kick Pads).*

#### Trigger Types for Drum Triggers

KiK	For kick
Snr	For snare drums
toM	For tom-toms; toms with a diameter of 14 inches or less
FLr	For floor toms; toms with a diameter of 15 inches or greater

*\* Use one of the trigger types for drum triggers when wanting to play the TD-5 using drum sounds that have been recorded onto separate tracks on a multitrack recorder.*

#### About Drum Triggers...

Drum triggers (pickups for acoustic drums) provide output of trigger signals which express the varying degrees of force used when hitting an acoustic drum.

*\* If using a Drum trigger, please refer to "Playing the TD-5 with Acoustic Drums" (p. 44).*

---

## 2. Adjusting the Sensitivity of a Pad (TRIGGER SENS - SEN)

This parameter adjusts the sensitivity of the Pad (1 to 16). Higher values result in greater sensitivity. Striking the Pad when making this setting causes the velocity value (1 to 127) to appear in the display after a pause of a few seconds. Make the setting so that the value approaches 127 when you strike the Pad forcefully.

## 3. Preventing Accidental Triggering of a Pad (THRESHOLD - thr)

This causes the trigger signal to be read only if the Pad is struck with more than a certain level of force (the "threshold"). This can be used to prevent a Pad from sounding in response to extraneous vibrations from another Pad (the setting range is from 0 to 15). Only signal (2) in the illustration below will cause the unit to sound. Signals (1) and (3) will not.

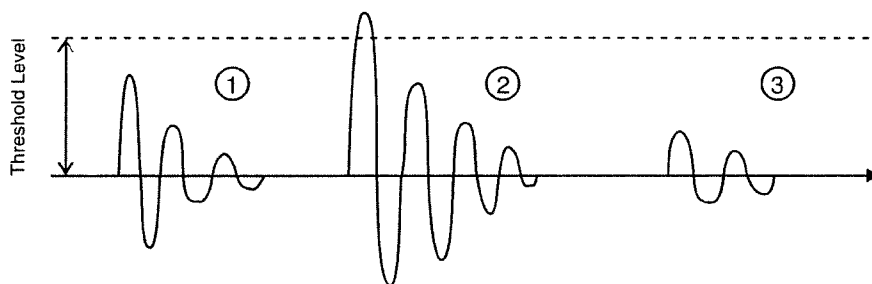

## 4. Curve Settings (CURVE - Cur)

Depending on the Pad or Drum Trigger, the relationship between the striking force and the change in loudness (the dynamics curve) may not be natural. This parameter lets you set the dynamics curve for an Instrument so it responds better to the varying levels of force you use when striking the Pad.

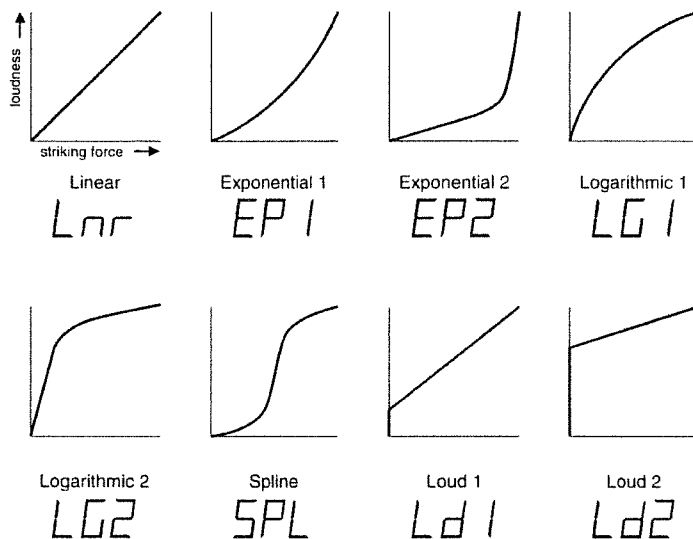

The degree of volume change obtainable relative to the strength used to strike the Pad will be reduced when set to "Ld1" or "Ld2."

---

---

## [Making the Settings]

**Step 1** Hold down the [EDIT] button for a few seconds. This illuminates the button, and takes you to the Advanced Edit mode. When you are in the Advanced Edit mode, the display flashes more rapidly than in the Edit mode.

**Step 2** Press the button corresponding to the trigger parameter you want to edit.

The following chart shows the buttons that the trigger parameters are assigned to.

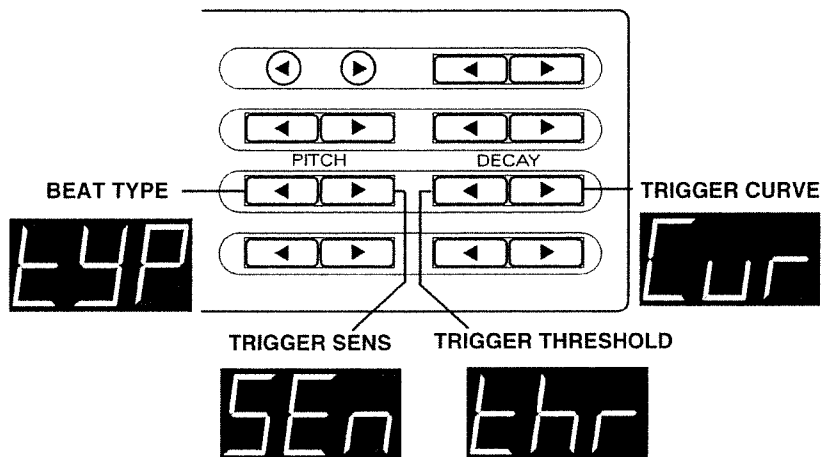

**Step 3** Strike the Pad whose settings you wish to change. The Pad indicator lights up.

\* *Trigger parameters are common (shared) for the center and rim of a Pad.*

**Step 4** Press the PATCH [◀] or [▶] button to change the setting.



**Step 5** Press [EDIT] to return to the Play mode.

---

### 3 About MIDI

MIDI is an acronym for “Musical Instrument Digital Interface,” and serves as a standard by which electronic musical instruments and computers can share musical data. The TD-5 conforms to the MIDI specification, so it can control or be controlled by another MIDI sound module, or synchronize its metronome with the tempo of a sequencer.

First, let’s take a brief look at how MIDI data is sent and received.

#### 1. MIDI Connectors

MIDI data is sent and received through the following three types of connectors. Use a MIDI cable to connect these connectors to other devices.

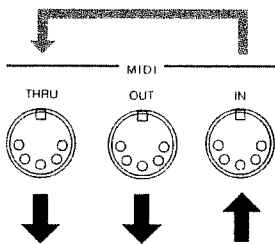

- MIDI IN: Receives data from other MIDI devices
- MIDI OUT: Transmits data to other MIDI devices
- MIDI THRU: Re-transmits the data received at MIDI IN

*\* The TD-5 has no MIDI THRU terminal.*

#### 2. MIDI Channels

MIDI allows you to independently control a number of MIDI devices over a single MIDI cable. This is possible because MIDI provides for multiple channels of control. You can think of MIDI channels as being similar to television channels. Although many broadcast channels are in the air at any one time (many channels of MIDI data are moving through a single cable), a television set receives only the channel to which it is set (the MIDI device receives only the channel to which it is set).

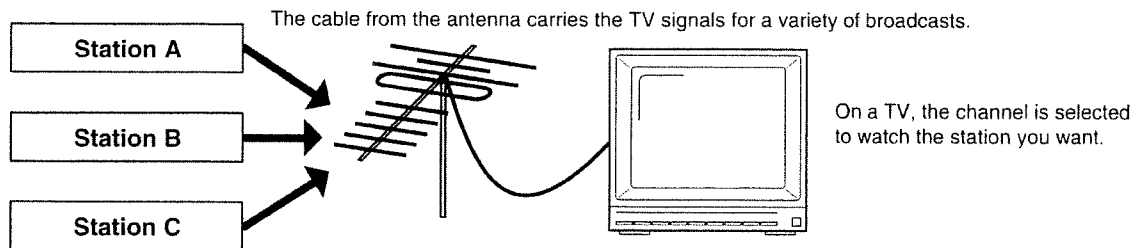

---

MIDI provides 16 channels (numbered from 1 to 16). The receiving device will only receive MIDI data when it is set to the same channel as the transmitting device. With the channel settings shown in the following, playing the keyboard causes only sound module B to play.

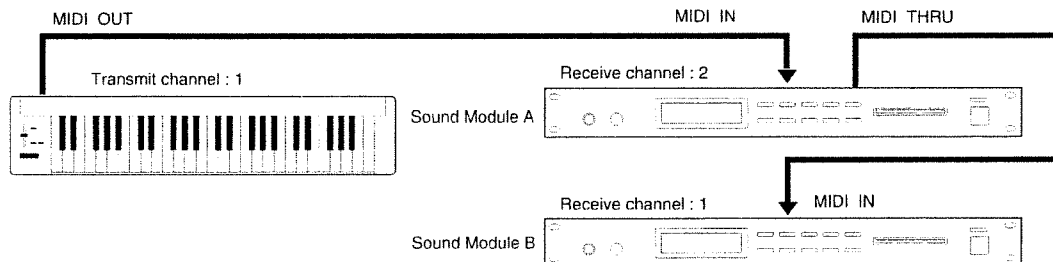

### 3. MIDI Data Used by the TD-5

In order to convey the many aspects of musical expression, MIDI provides for a wide variety of MIDI data types, or messages. MIDI messages can be broadly categorized into two groups: data that is differentiated by channel (Channel messages), and data that is common to all channels (System messages).

#### a. Data Differentiated by Channel (Channel Messages)

Channel messages are for carrying musical performance data. Virtually all aspects of control can normally be accomplished with just these messages.

##### Note Messages

These messages provide notice that a Pad has been struck. (A keyboard would transmit these messages when keys are played.) Note messages convey the following information.

- Note Number: A number assigned to each Pad (a number indicating the position on a keyboard)
- Note On: A message generated when a Pad is struck (when a key is played)
- Velocity: How strongly the Pad was struck (how strongly the key was played)

##### Aftertouch Messages

Aftertouch messages are transmitted by some keyboards when you apply additional pressure on a key after playing it. The degree of pressure (aftertouch) can be used to control various aspects of the sound. There are two types of aftertouch messages. Data which is transmitted independently for each key is called polyphonic aftertouch (polyphonic key pressure), and data which is transmitted for the overall keyboard (without differentiating between individual keys) is called channel aftertouch (channel key pressure).

The TD-5 transmits Polyphonic Aftertouch messages when the rim of a PD-7 or PD-9 Pad is squeezed or released.

---

---

### **Program Change Messages**

These messages are usually used to select sounds. Sound can be selected for Program Numbers from 1 to 128.

On the TD-5, each Patch has an assigned Program Number. Changing a Patch causes the corresponding Program Number to be sent, and this makes it possible to change the sound on an external sound module (p. 36). In the same way, the TD-5's Patch changes when it receives a Program Change message from another MIDI device. The Program Numbers for the TD-5 are "locked in" so they are the same as the Patch Numbers (1 to 32).

No Patch change takes place if a Program Number from 33 to 128 is received.

Settings for the transmission/reception of Program Change messages are made using the PROGRAM CHANGE SWITCH setting (p. 36).

### **Control Change Messages**

These messages convey various types of information that make a musical performance more expressive. Each message carries a controller number that indicates the function it is to control. The result depends on the MIDI device.

The TD-5 transmits the performance data of the Hi-hat Control Pedal as control change messages. The particular Control Change that will be sent is determined by the setting for FD-7 Control Change (p. 37).

### **b. Data Not Differentiated by Channel (System Messages)**

System messages include information for relaying data, information for controlling tempo synchronization, and other information for keeping a MIDI system running smoothly.

#### **Exclusive Messages**

Exclusive messages are used to send and receive data which is unique to a particular device, such as Patch data. This type of data can be received and sent between devices of an identical type from the same manufacturer. For details, refer to "MIDI Implementation" (p. 57).

#### **Realtime Messages**

These messages are used during synchronized play.

The TD-5 is capable of sending and receiving the timing clock and start/stop messages used to synchronize the tempo of the metronome and another MIDI device ("MIDI SYNC setting," p. 35).

#### **Active Sensing (Realtime Messages)**

These messages are used to monitor the integrity of MIDI connections. If no MIDI messages are received within a specific length of time, the device assumes that the connection has been broken (e.g., a cable has been disconnected) and resets the MIDI messages it has received up to then according to a specific procedure.



## 4 Note Numbers Assigned to Pads

Note Numbers indicate the numerical position of the keys on a keyboard, with middle C (C4) being number 60.

**Correspondence between  
Note Numbers and Note Names**

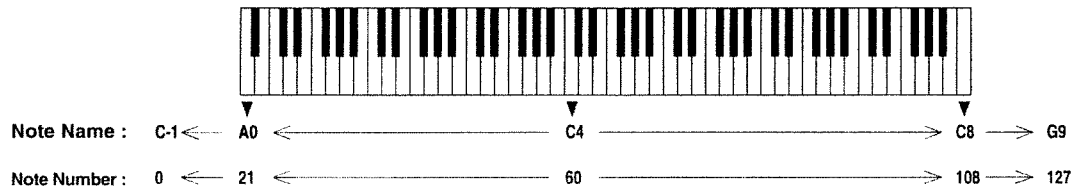

*\* On a keyboard, Note Numbers are generally used to differentiate pitch, but on a rhythm sound module (such as the TD-5) they are used to differentiate between drum sounds (Pads).*

On the TD-5, Note Numbers are permanently assigned to each of the connected Pads (TRIGGER INPUT jacks). The center and rim of a Pad have separate Note Numbers.

*\* The TD-5's Note Number assignments cannot be changed.*

Trigger Input	Center	Rim
1/KICK	36	35
2/SNARE	38	40
3/HI-HAT	(See Note)	
4/CRASH	49	52
5/TOM1	48	50
6/TOM2	45	47
7/TOM3	41	43
8/RIDE	51	53

*Note: The 3/HI-HAT jack switches between three Note Numbers, depending on your foot position when using the optional FD-7 Hi-hat Control Pedal.*

Trigger Input	Center	Rim
Open Hi-hat	46	26
Closed Hi-hat	42	22
Pedal Hi-hat	44	— *1

If you do not want note messages to be transmitted/received, select "OFF" for the MIDI CHANNEL setting (p. 35).

*\*1 Note numbers will not be transmitted (and no sound will be heard) when a Hi-hat Instrument has been assigned to the rim for 3/HI-HAT, and you attempt to play the sound using a pedal-only technique while either opening or closing the hi-hat (without striking the Pad).*

## [Background Instruments]

The TD-5 has a built-in set of Instruments which are assigned Note Numbers 27 to 87 (except for those Note Numbers assigned to Pads). These are called "Background Instruments." These Background Instruments are shared by all of the Patches. The Background Instruments cannot be played by way of the Pads, but they can be played by MIDI messages received from an external device when the TD-5 is used as a rhythm sound module.

At the factory defaults, the Instrument mappings (Note Numbers 35-81; combining Pads and Background Instruments) for Patches 1 through 29 are for the most part compatible with the General MIDI Percussion Map in the General MIDI System. These Patches have all the sounds (Instruments) for the Note Numbers from 35 to 81 arranged so they provide General MIDI compatibility.

**\* If Patch 30, 31, or 32 is selected while the factory defaults are still in effect, the Instruments sounded by playing the Pads will be percussion or sound effects, so they do not accord with the General MIDI Percussion Map.**

**General MIDI System:** The General MIDI System provides a framework for the creation of music data that is not restricted to a particular manufacturer or model. It is a set of universal specifications for sound generating devices agreed to by the Japan MIDI Standards Committee (JMSC) and the MMA (MIDI Manufacturers Association) of the U.S.A.

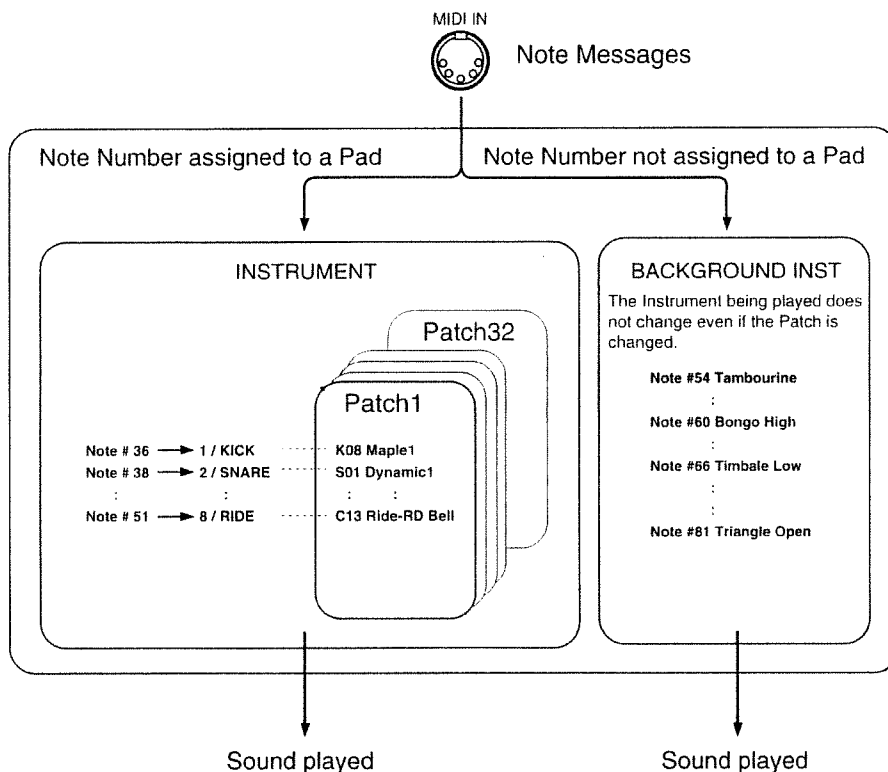

Refer to p. 54 for a list showing the correspondences between Note Numbers and Background Instruments.

**\* You can use a MIDI keyboard to edit the Background Instruments. Playing a key on a keyboard connected to the MIDI IN jack while in the Edit mode lets you edit the Background Instrument to which the corresponding Note Number is assigned. (See "Editing a Background Instrument" on p. 40.)**

---

---

## 5 Settings for MIDI-related Functions

When using the TD-5 with an external MIDI device that has been connected, the settings for the following functions can be made as required.

### 1. Setting the MIDI Channel (Basic Channel)

You need to set the basic channel (oFF; 1-16) over which Channel messages (Note messages, Program Changes, Control Changes, and Polyphonic Aftertouch) will be transmitted/received. When you do not want messages received at MIDI IN to cause the Instruments to be sounded, or do not want to make use of the MIDI Remote feature (p. 40), it can be set to "oFF." Even while this is set to "oFF," MIDI clock and start/stop information will continue to be received if the setting for MIDI SYNC is at "on." Ordinarily set to 10.

**Step 1** Hold down the [EDIT] button for a few seconds. This puts you into the Advanced Edit mode.

**Step 2** Press the LEVEL [◀] button.



**Step 3** Press PATCH [◀] or [▶] to make the setting.

- oFF Channel message transmission/reception disabled.
- 1-16 Channel messages will be transmitted/received on the set channel.

**Step 4** Press [EDIT] again to return to the Play mode.

### 2. Synchronizing the metronome with an External MIDI Device (MIDI SYNC Setting)

This setting determines whether the tempo of the metronome is to be set by the TD-5, or is to be synchronized with an external MIDI device. When set to "oFF" the metronome is played at the tempo set for TEMPO, but when at "on" the tempo will sync with a connected external device, such as a sequencer or rhythm machine. (Only tempos from 40 to 250 are acceptable, however.) When set to "on," the metronome can also be started and stopped using the external MIDI device. This setting is normally set to "oFF."

**Step 1** Hold down the [EDIT] button for a few seconds. This puts you into the Advanced Edit mode.

**Step 2** Press the LEVEL [▶] button.



**Step 3** Press the PATCH [◀] or [▶] button to make the setting ("oFF" or "on").

- oFF Plays at tempo set on this unit (standard setting).
- on Syncs with the tempo of the external unit.

**Step 4** Press [EDIT] again to return to the Play mode.

---

### 3. Switching the Sound of an External MIDI Sound Module (PROGRAM CHANGE SWITCH)

When you change to a different Patch on the TD-5, a Program Change message is sent, allowing you to have the sound on an external sound module be changed as well. Also, when in the Play mode, the TD-5 will change to a different Patch when a Program Change message is received from another MIDI device.

The Program Numbers sent and received by the TD-5 are fixed to be the same as the Patch Numbers (1 to 32).

For instance, if Program Number 9 is received from an external MIDI device, the TD-5 changes to Patch Number 9. The correspondence between the Patch Numbers and the Program Numbers cannot be changed.

#### How to Make the Setting for PROGRAM CHANGE SWITCH

**Step 1** Hold down the [EDIT] button for a few seconds. This puts you into the Advanced Edit mode.

**Step 2** Press the PAN [◀] button.

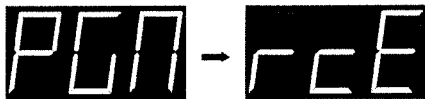

**Step 3** Press the PATCH [◀] or [▶] button to switch the setting.

oFF	Program Change transmission/reception disabled
rcE	Program Change reception enabled
trS	Program Change transmission enabled
r-t	Program Change transmission/reception enabled

**Step 4** Press [EDIT] again to return to the Play mode.

*\* Set the channel of the connected MIDI device to "The same channel that the TD-5 is using" to make it possible to receive (or transmit) Program Change messages.*

*! No Patch change takes place if a Program Number from 33 to 128 is received. It is also impossible to send Program Numbers from 33 to 128.*

---

#### 4. Setting FD-7 Control Changes

The setting below allows you to select the type of Control Change you want to be transmitted when the FD-7 is operated.

By operating an FD-7 connected to the TD-5, you can use it for hi-hat control with the TD-7 or SPD-11 when you connect the MIDI OUT jack on the TD-5 to the MIDI IN jack on the TD-7 or SPD-11.

Additionally, hi-hat control over the TD-5 can be accomplished using the reception of Control Changes from an external unit (the type specified here).

**Step 1** Hold down the [EDIT] button for a few seconds. This puts you into the Advanced Edit mode.

**Step 2** Press PAN [▶].

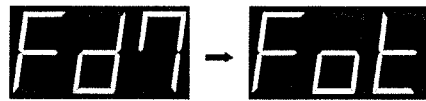

**Step 3** Select the type of Control Change to be transmitted by pressing PATCH [◀] or [▶].

Fot	Foot Control	Ctrl #4
Mod	Modulation	Ctrl #1
HLd	Hold 1	Ctrl #64
Gn1	General Purpose Controller-1	Ctrl # 16
Gn2	General Purpose Controller-2	Ctrl # 17

*\* When controlling the TD-7, set it to "Fot." To control an SPD-11, set it to "Mod."*

---

---

## 5. Saving Data in an External MIDI Device (Bulk Dump/Load)

You can exchange part or all of the data stored in the TD-5 with a sequencer or another TD-5. The operation of transmitting this data is called a “Bulk Dump,” and receiving this data is called a “Bulk Load.” These operations make use of Exclusive messages, which are a type of MIDI message that is meaningful only to a specific device.

### a. How to Send Data (Bulk Dump)

Connect the MIDI OUT jack on the TD-5 to the MIDI IN jack on the receiving device.

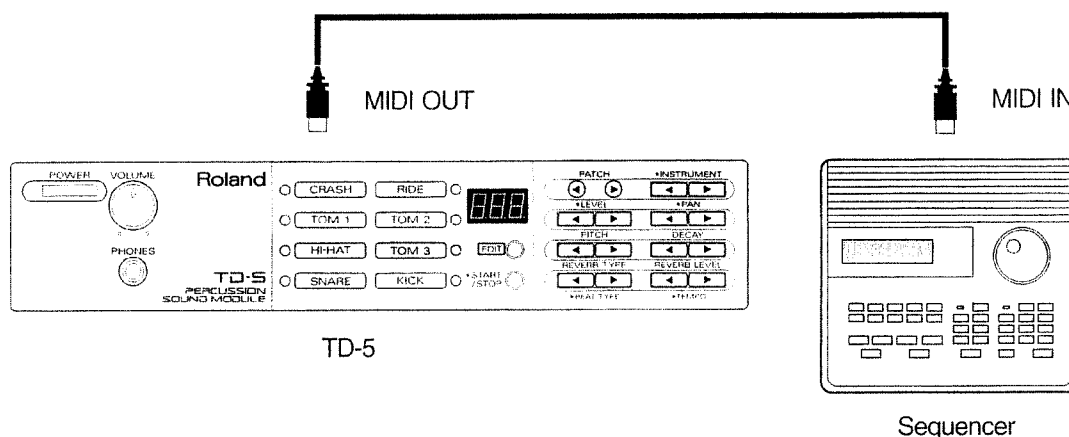

**Step 1** Hold down the [EDIT] button for a few seconds. This illuminates the button and puts you in the Advanced Edit mode.

**Step 2** Press the INSTRUMENT [▶] button.



**Step 3** Press the PATCH [◀] or [▶] button to choose the data to be sent (“All” or 1 to 32).

All All TD-5 settings are sent in a single batch

1 to 32 Only the settings (sound parameters) for the selected Patch Number are sent

**Step 4** Get the sequencer to start recording.

**Step 5** Press [START/STOP] to begin sending the data.

The data transmission will end after about 30 seconds for “All,” or immediately for a selection from 1 to 32.

If you want to halt the transmission of data, press [START/STOP] or [EDIT].

**Step 6** Press [EDIT] to return to the Play mode (the button light goes out).

*\* On the TD-5, the basic channel setting also serves as the Device ID setting (number needed to identify devices when exchanging Exclusive data). When performing a bulk dump, the basic channel (that is, the Device ID) is used for sending the data. When later doing a bulk load, you need to set the basic channel to the channel that was used for the bulk dump.*

---

## b. How to Receive Data (Bulk Load)

Connect the MIDI IN jack on the TD-5 to the MIDI OUT jack on the transmitting device.

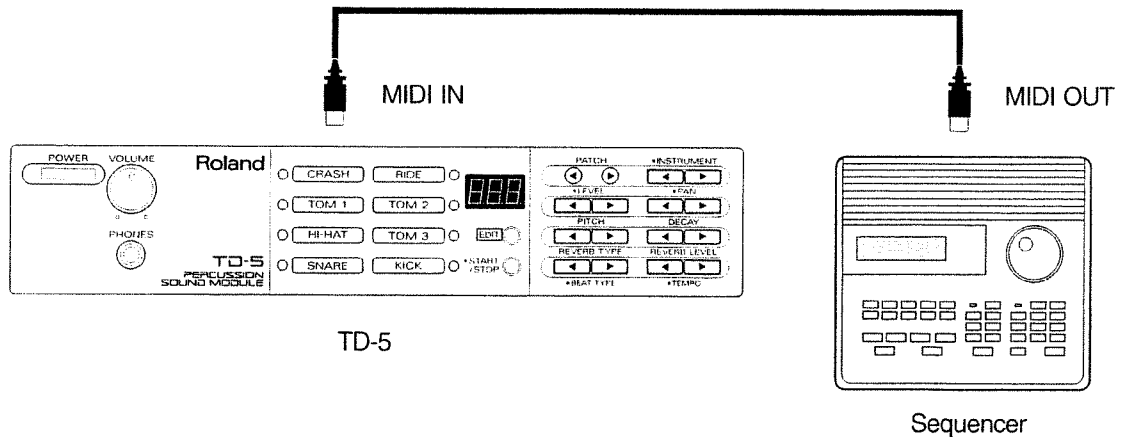

*\* Before beginning a bulk load, you must stop the metronome.*

*\* The TD-5's metronome will start in sync with the sequencer when it is started if the setting for MIDI SYNC is at "on." You need to set MIDI SYNC to "off."*

*! When data is received, the previous data settings are changed.*

Send the data from the transmitting device.

*\* The TD-5 can receive data regardless of its current mode.*

When the TD-5 starts to receive data, the following message appears in the display.



**Bulk Load in Progress**

*\* No operations are possible while data is being sent or received. Striking a Pad produces no sound. It may also take some time to process data after it has been received, so be sure to allow a reasonable interval when performing continuous reception.*

*\* You cannot carry out a bulk load unless you have the Device ID on the MIDI device transmitting the Exclusive data set to the same number as the basic channel on the TD-5. On the TD-5, the basic channel (MIDI channel) setting is also the Device ID setting. So when performing a bulk dump, you need to have the basic channel set to the same channel that was used for the bulk dump.*

---

## 6. Editing a Background Instrument (Editing Using a MIDI Keyboard)

You can use a MIDI keyboard to edit the Background Instruments (p. 34). This is called the MIDI Remote function. You can even edit Pad Instruments that correspond to the Note Numbers of the keyboard.

*\* MIDI Remote cannot be used when MIDI CHANNEL is set to "oFF."*

**Step 1** Connect the MIDI IN jack on the TD-5 to the MIDI OUT jack on the MIDI keyboard.

*\* Set the transmit channel on the MIDI keyboard to the same channel that the TD-5 is set to (default : 10).*

**Step 2** Press the [EDIT] button to illuminate the button light and enter the Edit mode.

**Step 3** Playing a key on the keyboard causes the Background Instrument with the corresponding Note Number to sound (p. 54). Select the Background Instrument that you wish to edit.

*\* If the Note Number for the key you play has been assigned to a Pad, the corresponding Pad indicator lights up. (If the Note Number has been assigned to the rim, then the Pad indicator flashes.)*

**Step 4** Edit the sound with the SOUND PARAMETER buttons. Editing is done in the same way as for Pads (p. 16).

**Step 5** Press [EDIT] to return to the Play mode.



---

---

## 6 Resetting Patch Settings to Their Factory Defaults (Patch Initialize)

When the TD-5 is shipped, it contains preset data for 32 Patches as well as system settings. You can freely overwrite this data. Whenever you desire, however, you can restore this data to the original factory settings. This procedure is called an “initialize” operation.

*! When you execute an initialize operation, any data you have edited and changed will be lost. If your TD-5 contains important data, you should make a note of the settings or carry out a Bulk Dump to store the data in an external device such as a sequencer (p. 38).*

**Step 1** Hold down the [EDIT] button for a few seconds. This puts you into the Advanced Edit mode.

**Step 2** Press the INSTRUMENT [▶] button.



**Step 3** Press the PATCH [◀] or [▶] button to choose the elements you wish to initialize (1 to 32, “bcK,” “SyS,” or “All”).

1 to 32	Settings for a single Patch
bcK	Background Instrument settings
SyS	Trigger, MIDI, and metronome settings
All	All TD-5 settings

*\* If you select “All,” the results are exactly the same as a System Initialize operation (p. 48).*

*\* To abort the initialization, press [EDIT] instead.*

**Step 4** Press the [START/STOP] button to start the initialization.

**Step 5** Press [EDIT] again to return to the Play mode.

# Chapter 5 Here's What Else You Can Do— Some Examples of Usage

## 1 Having the Metronome Play in Sync with the Tempo of an External Device

You can get the metronome (click) to sync with a sequencer's tempo as you play the drums while the sequencer plays song data.

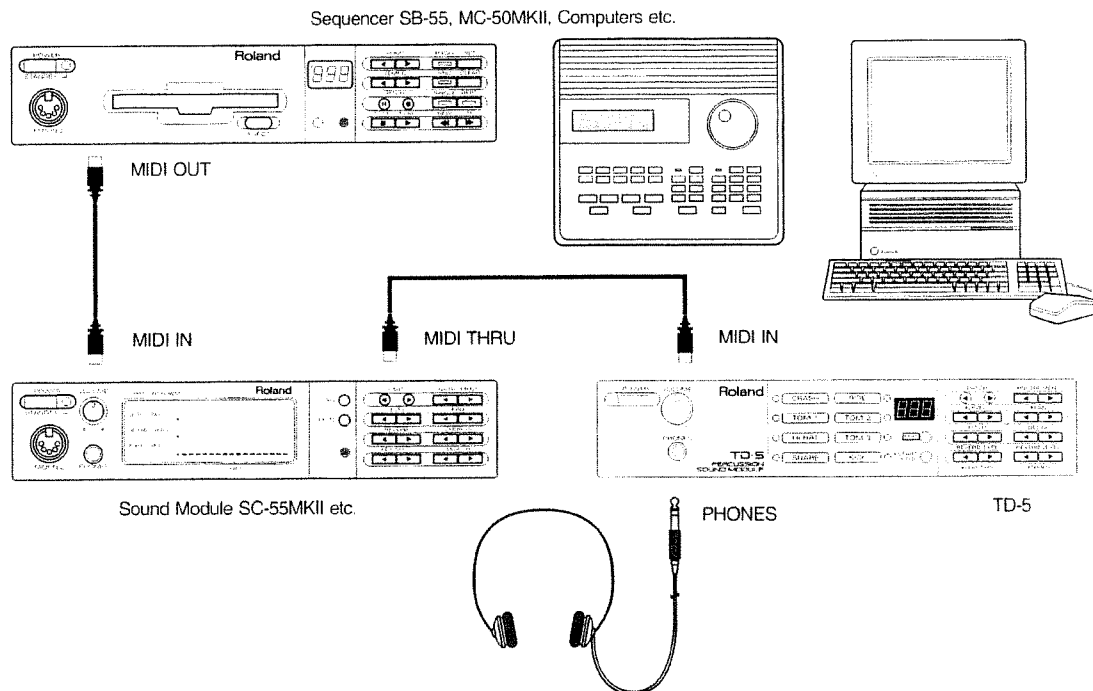

1. To synchronize the TD-5's metronome to the sequencer, set MIDI SYNC to "on" (p. 35).

2. When you switch the sequencer to the play mode, the TD-5's metronome will sound in time with the sequencer's tempo.  
(start/stop will be under the control of the sequencer.)

\* You can alter the setting for BEAT TYPE if you want to have the metronome sound eighth notes or triplets.

\* If you want the metronome sound to be heard only through the headphones, with no output going to the speakers, set METRONOME PAN to "Pho" (p. 24).

\* With this connection setup, when you play the drums in time with a GS music data or General MIDI score, the data for the drum part sent from the sequencer (channel 10) is played on the SC-55MKII and the TD-5. Mute the drum part on the SC-55MKII and set MIDI CHANNEL on the TD-5 to "oFF" (p. 35). This lets you play with only the metronome synchronized with the sequencer's tempo.

GS Format: The GS Format is Roland's set of universal specifications which were created in the interest of standardizing the way sound modules operate when MIDI is used for the performance of music.

---

---

## 2 Recording and Playing Back a Percussion Performance

You can use a sequencer to record a musical performance that you play on a compact drum system using the TD-5.

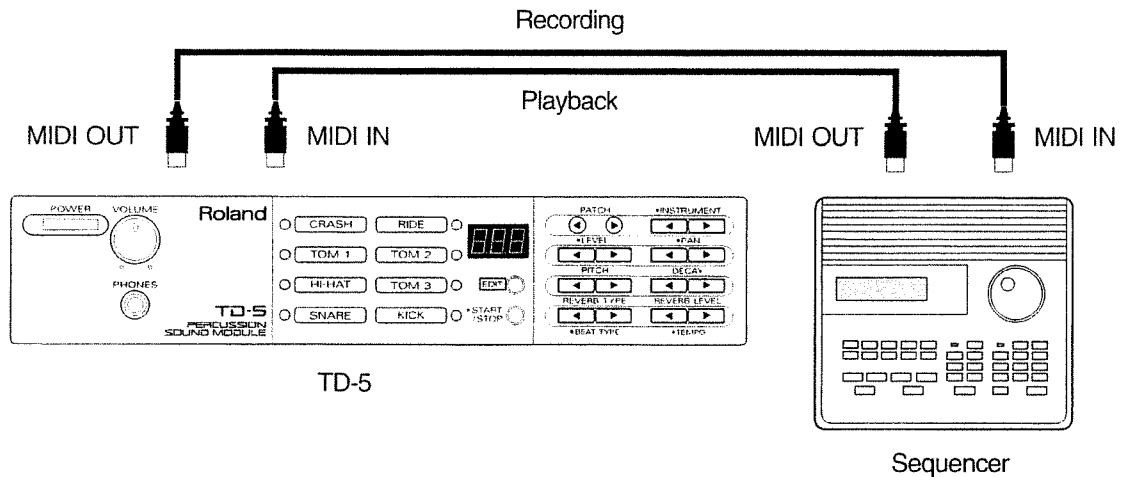

### 1. Set up the sequencer for realtime recording.

\* *“Realtime recording” is a method you can use to record what you play just as it is, without any changes.*

\* *When synchronizing the TD-5’s metronome to the sequencer, set MIDI SYNC on the TD-5 to “on” (p. 35). If you want the TD-5’s metronome sound to be heard only through the headphones, with no output going to the speakers, set METRONOME PAN to “pho” (p. 24).*

### 2. Start recording on the sequencer.

3. You can now play a compact drum system using the TD-5.

4. When you’ve finished recording, return to the start of the song and play it back.

\* *The system not only records and plays back the performance data you create when you strike the Pads, but it also records and plays back Pad chokes and Hi-hat Control Pedal operations. These are recorded and played back as Control Change messages.*

---

---

### 3 Playing the TD-5 with Acoustic Drums

By using a Drum Trigger, you can play the sound module of the TD-5 by means of an acoustic drum.

#### Step 1 Install the Drum Trigger on the acoustic drum.

*\* Refer to the owner's manual for the Drum Trigger for an explanation of how to install the Drum Trigger and any important points regarding its use.*

Drum	Where to Install
Kick	On the playing head, 5 to 10 cm from the rim
Snare drum	On the playing head, 2 to 3 cm from the rim
Tom tom	On the shell, next to a lug located about 2 to 3 cm from the playing head rim *1
Floor tom	On the shell, next to a lug located about 2 to 3 cm from the playing head rim *1

*\*1 Install it on the head if the level output by the trigger is too low.*

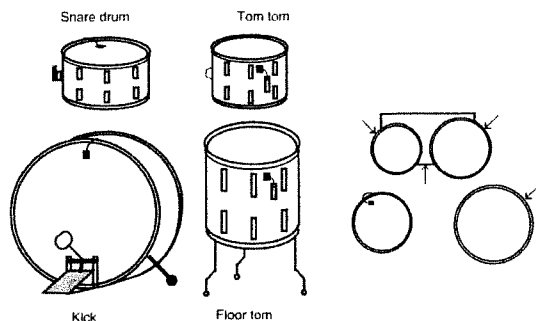

#### Step 2 Use a mono cable to connect the Drum Trigger to the TRIGGER INPUT jack.

#### Step 3 Set the trigger parameters (p. 27).

These are the recommended settings for the trigger parameters when a Drum Trigger is connected.

Drum used	TRIGGER TYPE	TRIGGER SENS	THRESHOLD	CURVE
Kick	KiK	12	2	Lnr
Snare drum	Snr	12	2	Lnr
Tom tom	toM	14	1	Ld1
Floor tom	FLr	14	1	Ld1

*\* You may need to make slight adjustments in the setting to obtain the best results, because the way in which the trigger behaves will vary depending on the drum being used.*

#### Step 4 When you strike the drum, the Instrument assigned to the TRIGGER INPUT jack plays.

To avoid having the drum trigger pick up any extraneous vibrations, try to keep all cords connected to the drum triggers from touching the rim or shell.

*\* Always mute the kick and snare drums. If using a ring mute, be careful not to have stray portions of the ring mute overlap onto the drum trigger.*

## Settings for Reducing Double-Triggering and Crosstalk (Acoustic Trigger Parameters)

Double triggering and crosstalk can occur depending on how your drums are set up, and on the condition they are in (including how well they are tuned). Such problems can arise even when the trigger type is set correctly. The settings that follow allow you to correct for these problems.

### When wanting to have each hit sound solidly:

Raise the setting for the trigger threshold so it is just at the point where double triggering and crosstalk no longer occur. If at the same time you do not really need to express volume changes that much, you could select "Ld2" for the trigger curve so you are sure to obtain plenty of volume with each hit.

### To express rolls or delicate nuances:

The trigger type (which needs to be set to accommodate the type of drum on which a drum trigger has been installed) incorporates four parameters for preventing double triggering and crosstalk (SCAN TIME, RETRIGGER CANCEL, MASK TIME, CROSSTALK). Ordinarily, the settings for these four parameters (acoustic trigger parameters) cannot be altered. However, by performing the steps explained in the following, you can have them added as acoustic trigger parameters that are available for adjustment in the Advanced Edit mode.

**Step 1** Hold down both [EDIT] and PITCH [◀] while you turn on the power.

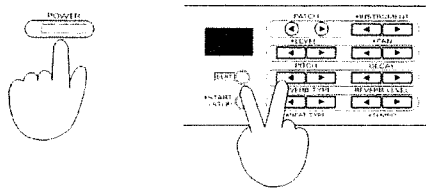

**Step 2** Press PATCH [◀] or [▶] to make the setting. Set it to "on."

- oFF Usual settings
- on The acoustic trigger parameters are added to the Advanced Edit mode

**Step 3** Turn power off, then on again.

*\* Once set to "on," it remains so until switched back to "oFF."*

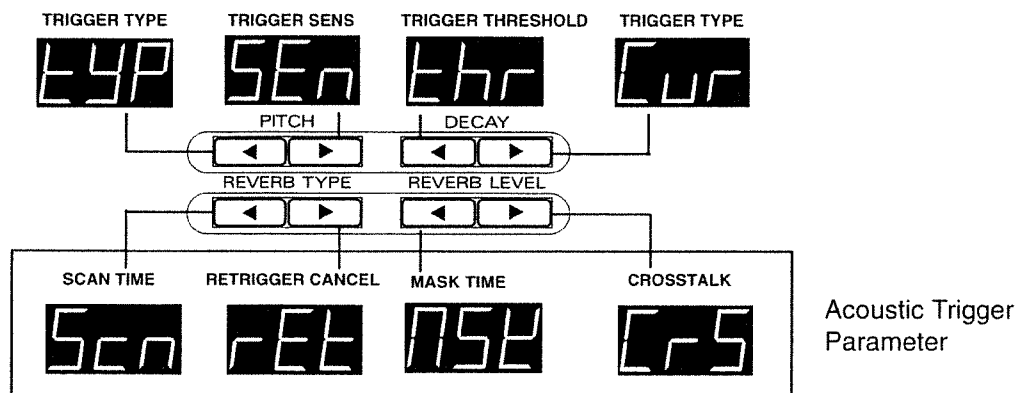

*\* The Acoustic trigger parameters are set in the same way as the other parameters in the Advanced Edit mode.*

*\* They can be set with respect to each TRIGGER INPUT the same way as with other trigger parameters.*

*\* If you change the Trigger Type, the values set for the four extended parameters are put at their default values. You will need to set these four parameters after having selected a new Trigger Type.*

---

---

## 1. SCAN TIME - Scn

Here you set the length of time the trigger signal will be detected (0 to 4.0 ms). Depending on the type of drum and drum trigger being used, the time it takes for the waveform of the trigger signal to reach its peak can be slightly different. If the scanning isn't working as good as it should, you might obtain varying levels of volume even though hitting the Pads with an identical amount of force. By altering the SCAN TIME, you can adjust the amount of time that the unit will detect the trigger signal. This lets you fine tune the unit so it will more accurately detect the alterations in hitting force that you use. Try to set the SCAN TIME so it is at the lowest value you can place it at while still obtaining the alterations in volume you need.

While altering the setting, the value (1-127) of the velocity used when striking the Pad will be shown momentarily in the display.

## 2. RETRIGGER CANCEL - rEt

This setting (1-16) allows you to cancel the double triggering that can occur as a result of erratic trigger waveforms. Some waveforms for signals that can be output by drum triggers are shown below.

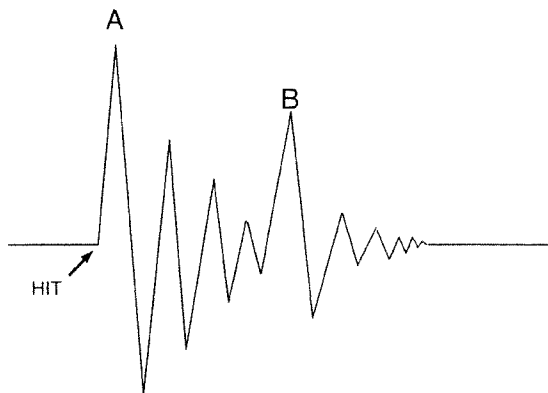

When the Pad is hit, it would be fine if sound were produced only at point A, but since the waveform is erratic, sound is also mistakenly produced at point B as well. In situations like this, you can simply set RETRIGGER CANCEL to a high value, and sound will no longer be produced at point B. On the other hand, if some sounds get left out when playing rolls, you can set it to a lower value.

## 3. MASK TIME - MSK

This parameter allows you to specify an amount of time (starting after a drum is hit) during which you do not want any further signals to be recognized, even though a multiple number of signals have been generated (range: 0-64 ms). It can be altered in 4 ms increments. For example, this setting can be used when you want to prevent bouncing with Kick Pads (even though you think you hit it only once, the sound is produced a number of times).

## 4. CROSSTALK - CrS

This setting allows you to prevent sounds that can be produced in error because of vibrations reaching one Pad from another that is mounted on the same stand or nearby. The higher the value, the more you can prevent such crosstalk from occurring. However, this also makes it easier for the sound of a weaker-played drum to be left out when played at the same time as one struck more loudly.

Try to select a setting which is at the lowest value you can place it at while still obtaining the amount of crosstalk prevention you need (possible values: oFF, 30, 40, 50, 60, 70, 80). No processing is performed when set to "oFF."

---

---

## Order for Setting Trigger Parameters for Drum Triggers

First, set these trigger parameters:

Threshold : 0

Curve : Lnr

Next, alter the parameter values in the following order:

### 1. Trigger Type (KiK, Snr, ToM, FLr)

Select the Trigger Type which matches the trigger you have connected to your drum.

### 2. Trigger Sens (1-16)

Set this to a value which provides a reading of 127 for the velocity when you hit the Pad with the greatest force.

### 3. Scan Time (0.0 to 4.0 ms)

This should be set to the lowest value you can put it at while still obtaining a suitable amount of change in volume, correctly reflecting the changes in striking force you use.

### 4. Retrigger Cancel (1-16)

This should be set to the lowest value you can place it while getting unwanted multiple hits to stop occurring when you hit only once.

### 5. Mask Time (0-64 ms)

When necessary, this can be set to the lowest value which still prevents unwanted multiple hits from occurring.

### 6. Crosstalk (oFF, 30, 40, 50, 60, 70, 80)

If another nearby drum equipped with a trigger causes the drum in question to sound mistakenly, set this to the lowest value you can place it while still eliminating crosstalk.

### 7. Threshold (0-15)

When necessary, this can be set to the lowest value that eliminates sounds being produced in error.

### 8. Curve (Lnr, EP1, EP2, LG1, LG2, SPL, Ld1, Ld2)

Select whichever curve is best.

*\* In some cases, it may be better to alter the above order.*

---

---

## 4 Using the TD-5 as a Sound Module

While the TD-5 is being used as a sound module, timing delays could begin occurring if it receives an excessive amount of MIDI messages. To prevent this, you can perform the steps below, and the unit will no longer process signals from the trigger inputs. As a result, it will be able to more quickly sound the notes it receives in the form of MIDI messages. When set this way, however, you will not be able to use the Pads (trigger inputs) or the Hi-hat control pedal.

**Step 1 Turn off the power.**

**Step 2 While holding down the INSTRUMENT [▶] button, turn the power back on.**

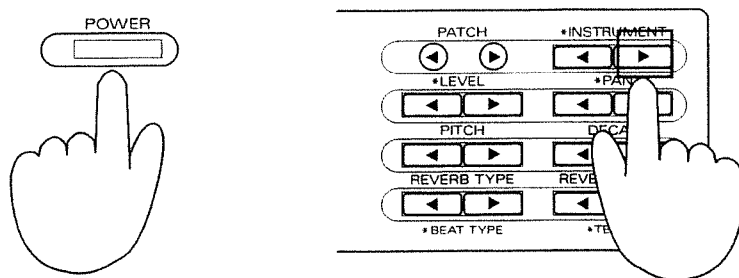

All the Pad indicators will light briefly when power is turned on.

*\* This setting is canceled when you switch off the power.*

## 5 Resetting All Settings to Their Factory Defaults (System Initialize)

**Step 1 Turn off the power.**

**Step 2 While holding down the [EDIT] and [START/STOP] buttons, switch the power back on. This makes the “Int” display flash.**

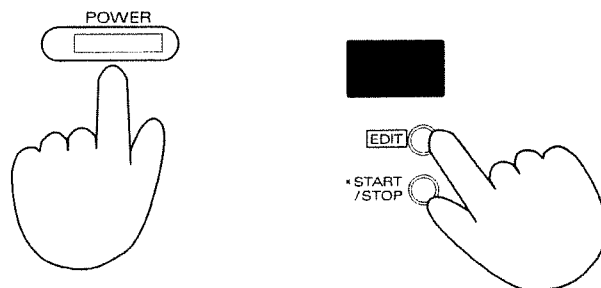

*\* If you want to stop now without initializing, press [EDIT].*

**Step 3 Press [START/STOP] to begin the initialization.**



# Chapter 6 Reference

---

## 1 If You Think There's a Problem...

If the TD-5 does not perform as expected, refer to this section. If you can not solve the problem, discontinue use immediately, and contact your Roland dealer or the nearest Roland service station as soon as possible.

### No sound

- Are the TD-5 and the amp turned on?
- Are connections correct and secure?
- Is the volume for the TD-5 turned up high enough?

### No sound played when a Pad is struck (volume too low)

- Is the LEVEL for the Instrument set too low? ( p. 18)
- Is TRIGGER SENS set too low? ( p. 28)

### No sound when the Pad is struck softly

- Lower the TRIGGER THRESHOLD. ( p. 28)
- IS TRIGGER CURVE set to EP1 or EP2? ( p. 28)

### Volume doesn't change even though varying amounts of force are used to hit Pads

- Select a more suitable trigger curve.

### The indicators for all the Pads light up.

- Since the setting for Reverb Type is common to all the Pads, the indicators for all the Pads will light while altering the Reverb Type.

### Pad indicators light without reason

- If you have been playing at loud volumes through speakers located near the Pads, their sound may have caused triggering of the Pads. If this is the case, try changing the position of the Pads, or move the speakers farther away. If this doesn't fix the problem, raise the Threshold (p. 28) for the Pad which is being triggered in error.
- The indicator for a Pad will light whenever a Note Number assigned to it is received over MIDI. This is normal, and does not indicate a malfunction.

### Patches change seemingly without reason

- Check to make sure a foot switch connected to the Patch Shift jack is connected securely.
- Try changing the setting for the polarity switch on a foot switch connected to the Patch Shift jack.

### The metronome does not start

- If "Syc" appears in the display, you have MIDI SYNC set to "on." Switch this setting off.

### No metronome sound

- Is METRONOME LEVEL set too low? ( p. 23)
- The metronome's sound is not sent to the OUTPUT jacks if METRONOME PAN is set to "Pho." ( p. 24)

### The metronome volume cannot be adjusted

- The VOLUME knob has no effect when METRONOME PAN is set to "Pho." (p. 24)  
Adjust it using METRONOME LEVEL.( p. 23)

### The metronome tempo cannot be set

- Set MIDI SYNC to "oFF." (p. 35)

---

---

### **The Hi-hat Control Pedal doesn't work**

- The pedal cannot be controlled if it is assigned to a Pad other than a Hi-hat Instrument at 3/HI-HAT.
- Turn the power off and then on again to make the TD-5 recognize the Hi-hat Control Pedal. (p. 15)

### **Rim shots and chokes do not work on a PD-7 or PD-9 Pad**

- Is the connection secure?
- Are you using a mono cable? If so, use a stereo cable.

## **—Drum Trigger—**

### **A single strike produces multiple sounds (double trigger)**

- Is the Drum Trigger attached securely?
- Is TRIGGER TYPE set correctly? ( p. 27)
- Is TRIGGER THRESHOLD set too low? ( p. 28)
- See "Settings for Reducing Double-Triggering and Crosstalk." (p. 45)

*\* Setting and tuning the drum can help prevent double triggering in some cases. It is also effective to mute the drum. If you are using a ring mute on a snare drum, trim part of the mute so that it does not overlap the Drum Trigger.*

## **—MIDI—**

### **No sound even when MIDI messages are received**

- Make sure that the transmitting MIDI device is set to the same channel that the TD-5 is set to.

### **Program Change messages not received**

- Set PROGRAM CHANGE to "rcE." (p. 36)
- Program Change messages can be received only when in the Play mode. Make sure you are in the Play mode when receiving.

### **Program Change messages not transmitted**

- Set PROGRAM CHANGE SWITCH to "trS." (p. 36)

### **The Patches change spontaneously**

- Set PROGRAM CHANGE SWITCH to "oFF." (p. 36)

### **An Instrument not assigned to the Patch is played when MIDI data is received**

- The Instrument for the rim or a Background Instrument (p. 34) is being played. This is not a defect.

---

## 2 Error Messages

If a problem occurs during operation, an error message is displayed. The previous display can be returned to by pressing any button on the front panel. Take the appropriate action as described in this section to correct the problem.

Act SENS Err

MIDI cables linking external MIDI devices are not connected properly or may be damaged.  
>> Check the MIDI devices and the connections with them.

Load Err

Data could not be successfully bulk loaded.  
>> Try loading the data again.

Serial Err

MIDI data was not received correctly.  
>> If this message appears repeatedly, consult your dealer or the nearest Roland Service Center.

BUFFER FULL

Too much MIDI data was received from another MIDI device.  
>> Reduce the amount of data sent from the other MIDI device.

RAM TEST Err

The data in memory has been lost. Press any button on the front panel, and the unit will initialize all the data, then show the original display.

**\* All the data in the TD-5 will be reverted to the factory defaults in this case.**

ANALOG TEST Err









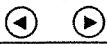

This message indicates an irregularity in the voltage of the Pad detection circuit.  
>> If this display continues to appear after turning the power off, then back on again, contact your nearest Roland Service Center. Sometimes this message will appear if you strike a Pad right after turning on the power. In this event, turn the power off and then on again.

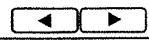
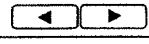
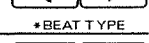
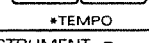
BATTERY Lo





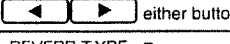



The memory-backup battery inside the TD-5 is almost dead.  
>> If the backup battery runs down completely, all data stored in the TD-5 will be lost. Contact your dealer or the nearest Roland Service Center as soon as possible to have the battery replaced.

### 3 Basic Operations

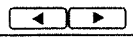
#### Play Mode

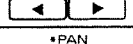
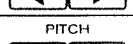
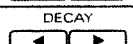
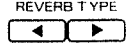
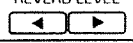
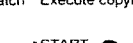
Changing the Patch			
Making settings for the Metronome	Starting the Metronome  *START /STOP ●	INSTRUMENT	*INSTRUMENT 
		LEVEL	*LEVEL 
		PAN	*PAN 
		BEAT TYPE	
		TEMPO	
Checking the SOUND PARAMETER settings	Strike the Pad you want to check  	INSTRUMENT	*INSTRUMENT Press either button 
		LEVEL	*LEVEL Press either button 
		PAN	*PAN Press either button 
		PITCH	PITCH Press either button 
		DECAY	DECAY Press either button 
		REVERB TYPE	REVERB TYPE Press either button 
		REVERB LEVEL	REVERB LEVEL Press either button 

#### Edit Mode

Press [EDIT]   Lighted    Slow flashing	SOUND PARAMETER settings	Strike the Pad you want to set  	INSTRUMENT	*INSTRUMENT 	Press [EDIT]   Not lighted    Lighted
			LEVEL	*LEVEL 	
			PAN	*PAN 	
			PITCH	PITCH 	
			DECAY	DECAY 	
			REVERB TYPE	REVERB TYPE 	
			REVERB LEVEL	REVERB LEVEL 	
Patch Copy	Select the copy-source Patch    Press [EDIT]    Select the copy-destination Patch    Execute copying  →  Lighted →  → *START /STOP ●				

## Changing Modes

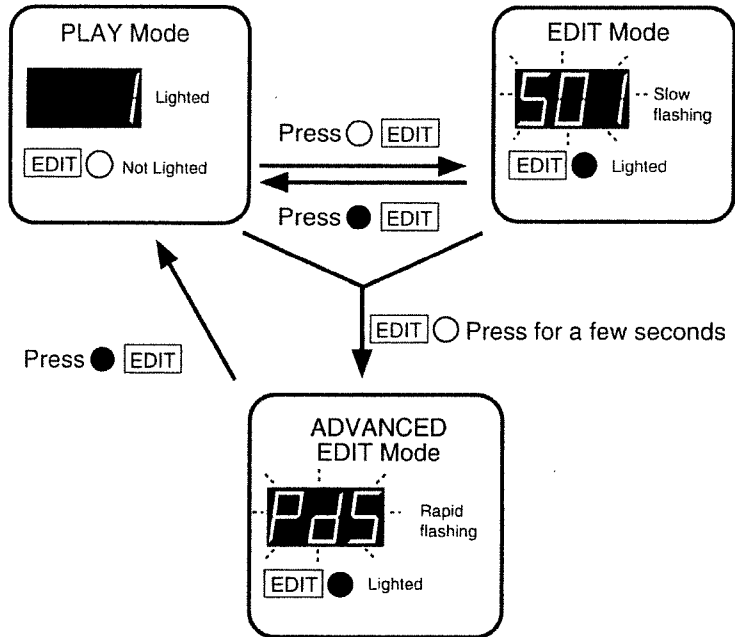

## Advanced Edit Mode

Press [EDIT] for a few seconds [EDIT] ● Lighted [Display] Fast flashing	TRIGGER parameter settings	TRIGGER TYPE <span style="float:right">PITCH</span> [←] [44P]	Strike the Pad you want to set 	Set the parameter value [PATCH] [←] [→]	Press [EDIT]
		TRIGGER SENS <span style="float:right">PITCH</span> [→] [55n]			
		TRIGGER THRESHOLD <span style="float:right">DECAY</span> [←] [66r]			
		TRIGGER CURVE <span style="float:right">DECAY</span> [→] [77c]			
MIDI parameter settings	MIDI CHANNEL <span style="float:right">*LEVEL</span> [←] [10H]	Set the parameter value [PATCH] [←] [→]	[EDIT] ○ Not Lighted [LED] Lighted		
	MIDI SYNC <span style="float:right">*LEVEL</span> [→] [54E]				
	PROGRAM CHANGE SWITCH <span style="float:right">*PAN</span> [←] [20n]				
	FD-7 CONTROL CHANGE <span style="float:right">*PAN</span> [→] [30n]				
	BULK DUMP <span style="float:right">*INSTRUMENT</span> [→] [81P]				
Initialize <span style="float:right">*INSTRUMENT</span> [←] [1nE]	Set the parameter value [PATCH] [←] [→]	Execute *START/STOP ●			

## 4 Note Number Assignment List

	Note #	Trigger Input	Background Inst	
	27		E01 Snaps	
	28		E06 Noise1	
	29		P24 CuicaMute	
	30		P24 CuicaMute	
	31		S59 Hall Stick	
	32		P10 Claves	
	33		E10 MetalStick	
	34		P30 TriangleOpen	
	35	1/KICK (rim)		
C2	36	1/KICK		
	37		S58 Side Stick	
	38	2/SNARE		
	39		P36 TR-808Clap1	
	40	2/SNARE (rim)		
	41	7/TOM 3		
	42	3/HI-HAT close *1		Note #22 3/HI-HAT (rim) close *2
	43	7/TOM3 (rim)		
	44	3/HI-HAT pedal *1		
	45	6/TOM 2		
	46	3/HI-HAT open *1		Note #26 3/HI-HAT (rim) open *2
	47	6/TOM2 (rim)		
C3	48	5/TOM 1		
	49	4/CRASH		
	50	5/TOM 1 (rim)		
	51	8/RIDE		
	52	4/CRASH(rim)		
	53	8/RIDE(rim)		
	54		P16 Tambourine1	
	55		C10 Splash	
	56		P09 Cowbell	
	57		C02 Crash2	
	58		P20 Vibra-Slap	
	59		C15 BrushRide	
C4	60		P01 BongoHigh	
	61		P02 BongoLow	
	62		P07 CongaHiMute	
	63		P04 CongaHOp-HMt	
	64		P06 CongaLowOpen	
	65		P18 TimbaleHigh	
	66		P19 TimbaleLow	
	67		P21 Agogo1	
	68		P21 Agogo1	
	69		P23 Cabasa	
	70		P14 Maracas	
	71		P27 WhistleShort	
C5	72		P26 WhistleLong	
	73		P12 GuiroShort	
	74		P11 GuiroLong	
	75		P10 Claves	
	76		P32 WoodBlock1	
	77		P33 WoodBlock2	
	78		P24 CuicaMute	
	79		P25 CuicaOpen	
	80		P29 TriangleMute	
	81		P30 TriangleOpen	
	82		P15 Shaker	
	83		P16 Tambourine1	
C6	84		E12 Random2	
	85		S59 Hall Stick	
	86		P35 Taiko	
	87		P35 Taiko	

\*1 The three Note Numbers for 3/HI-HAT are switched by operating the Hi-hat Control Pedal.

\*2 The assigned Note Numbers for 3/HI-HAT Pedal Closed Hi-hat and Pedal Open Hi-hat are #22 for closed and #26 for open.

For Background Instruments, these are the Instrument names that were assigned when the TD-5 was shipped from the factory.

---

---

## 5 Factory Default Settings

### Trigger Parameters

	TYPE	SENS	THRESHOLD	CURVE
1/KICK	Kd5	4	2	Lnr
2/SNARE	Pd5	3	2	Lnr
3/HI-HAT	Pd5	3	2	Lnr
4/CRASH	Pd5	3	2	Lnr
5/TOM1	Pd5	3	2	Lnr
6/TOM2	Pd5	3	2	Lnr
7/TOM3	Pd5	3	2	Lnr
8/RIDE	Pd5	3	2	Lnr

### MIDI

MIDI CHANNEL : 10  
MIDI SYNC : oFF  
PROGRAM CHANGE SWITCH : rcE  
FD-7 CONTROL : oFF

### Metronome

INSTRUMENT : VcE (voice)  
LEVEL : 9  
PAN : Ctr  
BEAT TYPE : 4 - 4  
TEMPO : 120

---



---

## 6 Blank Chart

PATCH No. \_\_\_\_\_

	KICK		SNARE		HI-HAT		CRASH		TOM1		TOM2		TOM3		RIDE	
	head	rim	head	rim	head	rim	head	rim	head	rim	head	rim	head	rim	head	rim
INSTRUMENT																
LEVEL																
PAN																
PITCH																
DECAY																
REVERB TYPE																
REVERB LEVEL																

## TRIGGER PARAMETER

	KICK	SNARE	HI-HAT	CRASH	TOM1	TOM2	TOM3	RIDE
TYPE								
SENS								
THRESHOLD								
CURVE								



## 7 MIDI Implementation

# Roland Exclusive Messages

### 1. Data Format for Exclusive Messages

Roland's MIDI implementation uses the following data format for all Exclusive messages (type IV):

Byte	Description
F0H	Exclusive Status
41H	Manufacturer ID (Roland)
DEV	Device ID
MDL	Model ID
CMD	Command ID
[BODY]	Main data
F7H	End of exclusive

#### •MIDI status: F0H, F7H

An Exclusive message must be flanked by a pair of status codes, starting with a Manufacturer ID immediately after F0H (MIDI version 1.0).

#### •Manufacturer ID: 41H

The Manufacturer ID identifies the manufacturer of a MIDI instrument that sends an Exclusive message. Value 41H represents Roland's Manufacturer ID.

#### •Device ID: DEV

The Device ID contains a unique value that identifies individual devices in the implementation of several MIDI instruments. It is usually set to 00H-0FH, a value smaller by one than that of a basic channel, but value 00H-1FH may be used for a device with several basic channels.

#### •Model ID: MDL

The Model ID contains a value that identifies one model from another. Different models, however, may share an identical Model ID if they handle similar data.

The Model ID format may contain 00H in one or more places to provide an extended data field. The following are examples of valid Model IDs, each representing a unique model:

01H  
02H  
03H  
00H, 01H  
00H, 02H  
00H, 00H, 01H

#### •Command ID: CMD

The Command ID indicates the function of an Exclusive message. The Command ID format may contain 00H in one or more places to provide an extended data field. The following are examples of valid Command IDs, each representing a unique function:

01H  
02H  
03H  
00H, 01H  
00H, 02H  
00H, 00H, 01H

#### •Main data: BODY

This field contains a message to be exchanged across an interface. The exact data size and content will vary with the Model ID and Command ID.

### 2. Address-mapped Data Transfer

Address mapping is a technique for transferring messages conforming to the data format given in Section 1. It assigns a series of memory-resident records—waveform and tone data, switch status, and parameters, for example, to specific locations in a machine-dependent address space, thereby allowing access to data residing at the address a message specifies.

Address-mapped data transfer is therefore independent of models and data categories. This technique allows use of two different transfer procedures: one-way transfer and handshake transfer.

#### •One-way transfer procedure (See Section 3 for details.)

This procedure is suited to the transfer of a small amount of data. It sends out an Exclusive message completely independent of the receiving device's status.

#### Connection Diagram

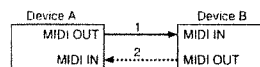

Connection at point 2 is essential for "Request data" procedures. (See Section 3.)

#### •Handshake-transfer procedure (This device does not use this procedure)

This procedure initiates a predetermined transfer sequence (handshaking) across the interface before data transfer takes place. Handshaking ensures that reliability and transfer speed are high enough to handle a large amount of data.

#### Connection Diagram

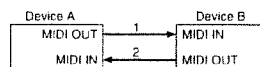

Connection at points 1 and 2 is essential.

### Notes on the above procedures

- There are separate Command IDs for different transfer procedures.
- Devices A and B cannot exchange data unless they use the same transfer procedure, share identical Device ID and Model ID, and are ready for communication.

### 3. One-way Transfer Procedure

This procedure sends out data until it has all been sent and is used when the messages are so short that answerbacks need not be checked.

For longer messages, however, the receiving device must acquire each message in time with the transfer sequence, which inserts 20 milliseconds intervals.

#### Types of Messages

Message	Command ID
Request data #1	RQ1 (11H)
Data set #1	DT1 (12H)

#### •Request data #1: RQ1 (11H)

This message is sent out when there is a need to acquire data from a device at the other end of the interface. It contains data for the address and size that specify designation and length, respectively, of data required.

On receiving an RQ1 message, the remote device checks its memory for the data address and size that satisfy the request.

If it finds them and is ready for communication, the device will transmit a "Data set 1 (DT1)" message, which contains the requested data. Otherwise, the device won't send out anything.

Byte	Description
F0H	Exclusive Status
41H	Manufacturer ID (Roland)
DEV	Device ID
MDL	Model ID
11H	Command ID
aaH	Address MSB
↑	↑
↑	↑
	LSB
ssH	Size MSB
↑	↑
↑	↑
	LSB
sum	Check sum
F7H	End of exclusive

- The size of the requested data does not indicate the number of bytes that will make up a DT1 message, but represents the address fields where the requested data resides.
- Some models are subject to limitations in data format used for a single transaction. Requested data, for example, may have a limit in length or must be divided into predetermined address fields before it is exchanged across the interface.
- The same number of bytes comprises address and size data, which, however, vary with the Model ID.
- The error-checking process uses a checksum that provides a bit pattern where the last 7 bits are zero when values for an address, size, and that checksum are summed.

### •Data set 1: DT1 (12H)

This message corresponds to the actual data transfer process. Because every byte in the data is assigned a unique address, a DT1 message can convey the starting address of one or more bits of data as well as a series of data formatted in an address-dependent order.

The MIDI standards inhibit non real-time messages from interrupting an Exclusive one. This fact is inconvenient for devices that support a "soft-thru" function. To maintain compatibility with such devices, Roland has limited the DT1 to 256 bytes so that an excessively long message is sent out in separate 'segments'.

Byte	Description
F0H	Exclusive Status
41H	Manufacturer ID (Roland)
DEV	Device ID
MDL	Model ID
12H	Command ID
aaH	Address MSB
	LSB
ddH	Data MSB
	LSB
sum	Checksum
F7H	End of exclusive

- A DT1 message is capable of providing only the valid data among those specified by an RQ1 message.
- Some models are subject to limitations in data format used for a single transaction. Requested data, for example, may have a limit in length or must be divided into predetermined address fields before it is exchanged across the interface.
- The number of bytes comprising address data varies from one Model ID to another.
- The error-checking process uses a checksum that provides a bit pattern where the last 7 bits are zero when values for an address, size, and that checksum are summed.

### •Example of Message Transactions

#### •Device A sending data to Device B

Transfer of a DT1 message is all that takes place.

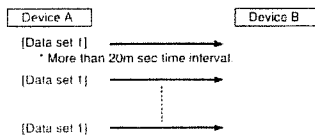

#### •Device B requesting data from Device A

Device B sends an RQ1 message to Device A. Checking the message, Device A sends a DT1 message back to Device B.

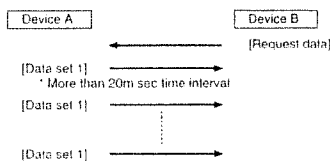

**[PERCUSSION SOUND MODULE]  
Model: TD-5  
MIDI IMPLEMENTATION**

**Date : Jun.22 1994  
Version : 1.00**

**1. TRANSMITTED DATA**

**§ Channel Voice Message**

**• Note off**

<u>Status</u>	<u>Second</u>	<u>Third</u>
9nH	kkH	00H

n=MIDI channel number: 0H – FH (ch.1 – ch.16)  
 kk=Note number: 16H, 1AH, 23H, 24H, 26H, 28H-35H  
 (22, 26, 35, 36, 38, 40-53)

**• Note on**

<u>Status</u>	<u>Second</u>	<u>Third</u>
9nH	kkH	vvH

n=MIDI channel number: 0H – FH (ch.1 – ch.16)  
 kk=Note number: 16H, 1AH, 23H, 24H, 26H, 28H-35H  
 (22, 26, 35, 36, 38, 40-53)  
 vv=Velocity: 01H – 7FH (1 – 127)

The TD-5 transmits the messages on the basic channel.  
 The trigger input are related to note numbers as shown below:

Trigger Input	Head	Rim
1/KICK	24H (36)	23H (35)
2/SNARE	26H (38)	28H (40)
3/HI-HAT	2EH (46)	1AH (26) (Open Hi-Hat)
4/CRASH	31H (49)	34H (52)
5/TOM1	30H (48)	32H (50)
6/TOM2	2DH (45)	2FH (47)
7/TOM3	29H (41)	2BH (43)
8/RIDE	33H (51)	35H (53)

The numbers under the title Rim are note numbers of rim shot is made using PD-7/9.

3/HI-HAT is provided with two more sets of note numbers which can be selected from the Hi-Hat control pedal.

	Head	Rim
Open Hi-Hat	2EH (46)	1AH (26)
Closed Hi-Hat	2AH (42)	16H (22)
Pedal Hi-Hat	2CH (44)	—

**• Polyphonic Key Pressure**

<u>Status</u>	<u>Second</u>	<u>Third</u>
AnH	kkH	vvH

n=MIDI channel number: 0H – FH (ch.1 – ch.16)  
 kk=Note number: 16H, 1AH, 23H, 24H, 26H, 28H-35H  
 (22, 26, 35, 36, 38, 40-53)  
 vv=Value: 00H, 7FH (0, 127)

The TD-5 transmits the messages on the basic channel when the rim of the pad is grabbed. This message is transmitted with value 7FH when the rim of the pad is grabbed; or value 00H when the rim of the pad is released.

When PD-7/9 is connected to 3/HI-HAT, the note number of either Open Hi-Hat, Closed Hi-Hat or Pedal Hi-Hat, whichever selected, is also transmitted.

**• Control Change**

The TD-5 transmits a value corresponding to the position of the Hi-hat Control Pedal on the basic channel.

The control message corresponding to FD-7 control change is transmitted.

**Modulation (Controller number 1)**

<u>Status</u>	<u>Second</u>	<u>Third</u>
BnH	01H	vvH

n=MIDI channel number: 0H – 0FH (ch.1 – ch.16)  
 vv=Modulation depth: 00H – 7FH (0 – 127)

**Foot Type (Controller number 4)**

<u>Status</u>	<u>Second</u>	<u>Third</u>
BnH	04H	vvH

n=MIDI channel number: 0H – 0FH (ch.1 – ch.16)  
 vv=Control value: 00H – 7FH (0 – 127)

**General Purpose Controller-1 (Controller number 16)**

<u>Status</u>	<u>Second</u>	<u>Third</u>
BnH	10H	vvH

n=MIDI channel number: 0H – 0FH (ch.1 – ch.16)  
 vv=Control value: 00H – 7FH (0 – 127)

**General Purpose Controller-2 (Controller number 17)**

<u>Status</u>	<u>Second</u>	<u>Third</u>
BnH	11H	vvH

n=MIDI channel number: 0H – 0FH (ch.1 – ch.16)  
 vv=Control value: 00H – 7FH (0 – 127)

**Hold 1 (Controller number 64)**

<u>Status</u>	<u>Second</u>	<u>Third</u>
BnH	40H	vvH

n=MIDI channel number: 0H – 0FH (ch.1 – ch.16)  
 vv=Control value: 00H – 7FH (0 – 127)

**• Program Change**

<u>Status</u>	<u>Second</u>
CnH	ppH

n=MIDI channel number: 0H – FH (ch.1 – ch.16)  
 pp=Program number: 00H – 1FH (prog.1 – prog.32)

The TD-5 transmits this message on the Basic Channel, When a patch is selected. Patches 1-31 correspond to program numbers 00H – 1FH (prog.1 – prog.32). The TD-5 will no transmit this message if program change switch is set at OFF or rCE.

**§ System Exclusive Message**

<u>Status</u>	<u>Data Byte</u>	<u>Status</u>
FOH	iiH,ddH,...,eeH	F7H

FOH: System Exclusive Message status  
 ii=ID number: an ID number(manufacturer ID) to indicate the manufacturer whose Exclusive message. Roland's manufacturer ID is 41H.  
 dd,...,ee=data: 00H – 7FH (0 – 127)  
 F7H: EOX (End Of Exclusive)

With the TD-5, the System Exclusive Messages can be used to transmit Bulk Dump of patch data and system data. For details refer to "3. Exclusive Communications" and "Roland Exclusive Messages."

## § System Real Time Message

### • Timing clock

Status  
F8H

The TD-5 continuously transmits this message when MIDI sync is set at oFF and will not transmit if on.

### • Start

Status  
FAH

The TD-5 transmits this message upon starting of metronome with MIDI sync set oFF.

### • Stop

Status  
FCH

The TD-5 transmits this message upon starting of metronome with MIDI sync set oFF.

### • Active Sensing

Status  
FEH

The TD-5 transmits this information at approx. 250 ms interval.

## 2. RECOGNIZED RECEIVE DATA

### § Channel Voice Message

#### • Note on

<u>Status</u>	<u>Second</u>	<u>Third</u>
9nH	kkH	wH

n=MIDI channel number: 0H - 0FH (ch.1 - ch.16)  
kk=Note number: 16H,1AH - 57H (22, 26 - 87)  
vv=Velocity: 01H - 7FH (1 - 127)

The TD-5 receives Note on messages on the basic channel.  
When the TD-5 receives a note number assigned to trigger input, it sounds the instrument set in the patch being selected. Otherwise, the TD-5 sounds the corresponding background Inst.

#### • Polyphonic Key Pressure

<u>Status</u>	<u>Second</u>	<u>Third</u>
AnH	kkH	wH

n=MIDI channel number: 0H - FH (ch.1 - ch.16)  
kk=Note number: 16H,1AH - 57H (22, 26 - 87)  
vv=Value; 00H - 7FH (0 - 127)

The TD-5 receives the message on the basic channel.  
When the received Value is 40H(64) or more, the TD-5 mutes the Trigger Input sound or Background Inst sound that is specified by the received Note number.

#### • Control Change

The TD-5 receives Note on messages on the basic channel.  
The TD-5 receives the control message set by FD-7 control change (except for volume and expression). Control change acts as Hi-Hat control pedal.

#### Modulation Depth (Controller number 1)

<u>Status</u>	<u>Second</u>	<u>Third</u>
BnH	01H	wH

n=MIDI channel number: 0H - 0FH (ch.1 - ch.16)  
vv=Modulation depth: 00H - 7FH (0 - 127)

#### Foot Type (Controller number 4)

<u>Status</u>	<u>Second</u>	<u>Third</u>
BnH	04H	wH

n=MIDI channel number: 0H - 0FH (ch.1 - ch.16)  
vv=Control value: 00H - 7FH (0 - 127)

#### General Purpose Controller-1 (Controller number 16)

<u>Status</u>	<u>Second</u>	<u>Third</u>
BnH	10H	wH

n=MIDI channel number: 0H - 0FH (ch.1 - ch.16)  
w=Control value: 00H - 7FH (0 - 127)

#### General Purpose Controller-2 (Controller number 17)

<u>Status</u>	<u>Second</u>	<u>Third</u>
BnH	11H	wH

n=MIDI channel number: 0H - 0FH (ch.1 - ch.16)  
w=Control value: 00H - 7FH (0 - 127)

#### Hold-1 (Controller number 64)

<u>Status</u>	<u>Second</u>	<u>Third</u>
BnH	40H	wH

n=MIDI channel number: 0H - 0FH (ch.1 - ch.16)  
w=Control value: 00H - 7FH (0 - 127)

#### Volume

<u>Status</u>	<u>Second</u>	<u>Third</u>
BnH	07H	wH

n=MIDI channel number: 0H - 0FH (ch.1 - ch.16)  
vv=Control value: 00H - 7FH (0 - 127)

The TD-5 receives Note on messages on the basic channel.  
This message controls volume of MIDI-on note and will not affect the note triggered by the pad.

#### Expression

<u>Status</u>	<u>Second</u>	<u>Third</u>
BnH	0BH	wH

n=MIDI channel number: 0H - 0FH (ch.1 - ch.16)  
w=Control value: 00H - 7FH (0 - 127)

The TD-5 receives Note on messages on the basic channel.  
This message controls volume of MIDI-on note and will not affect the note triggered by the pad.

#### • Program Change

<u>Status</u>	<u>Second</u>
CnH	ppH

n=MIDI channel number: 0H - 0FH (ch.1 - ch.16)  
pp=Program number: 00H - 1FH (prog.1 - prog.32)

The TD-5 receives Note on messages on the basic channel while in the Play mode.  
The TD-5 changes patches according to the received program number.  
The patch numbers according to the program number 01H-1FH(prog.1 - prog.32), respectively. The TD-5 will not receive this message when the program change switch is set at off or trS.

### § Channel Mode Message

#### • Reset All Controllers

<u>Status</u>	<u>Second</u>	<u>Third</u>
BnH	79H	00H

n=MIDI channel number: 0H - FH (ch.1 - ch.16)

The TD-5 receives the message on the basic channel.  
The TD-5 initializes the controllers on receiving this message.

Controller	Reset value
Modulation	0 (OFF)
Foot Type	0 (OFF)
General Purpose Controller-1	0 (OFF)
General Purpose Controller-2	0 (OFF)
Hold-1	0 (OFF)
Volume	127 (MAX)
Expression	127 (MAX)

## § System Exclusive Message

Status	Data Byte	Status
F0H	iiH, ddH, ..., eeH	F7H

F0H: System Exclusive Message status  
 ii=ID number: an ID number(manufacturer ID) to indicate the manufacturer whose Exclusive message. Roland's manufacturer ID is 41H.  
 dd, ..., ee=data: 00H – 7FH (0 – 127)  
 F7H: EOX (End Of Exclusive)

With the TD-5, the System Exclusive Messages can be used to transmit Bulk Dump of patch data and system data. For details refer to "3. Exclusive Communications" and "Roland Exclusive Messages."

## § System Common Message

### • Song Position Pointer

Status	Second	Third
F2H	mmH	llH

ll,mm=Value: 00H, 00H – 7FH, 7FH (0 – 16383)

When MIDI sync is set at on, the TD-5 receives this message while it is stopped in the play mode. It advances the metronome to the point corresponding to position.

## § System Real Time Message

### • Timing Clock

Status
F8H

When MIDI sync is set at on, the TD-5 receives this message while in the play mode.

### • Start

Status
FAH

When MIDI sync is set at on, the TD-5 receives this message while in the play mode.

### • Continue

Status
FBH

When MIDI sync is set at on, the TD-5 receives this message while in the play mode.

### • Stop

Status
FCH

When MIDI sync is set at on, the TD-5 receives this message while in the play mode.

### • Active Sensitive

Status
FEH

Whenever the TD-5 receives this message, it monitors the interval of the coming data. If the subsequent message has not arrived within 350ms after the previous data, it process as though it has received Reset All Controllers and stops monitoring receiving interval.

## 3. Exclusive Communications

TD-5 can do one-way communications to send and receive parameters for sequence and setup.

The Model ID included in the exclusive message should be 6EH. The device ID code should be Basic Channel of System. Note that the actual value that is set in the device ID field is smaller by one than the value set at parameter Basic Channel of System. (Specific examples are provided in "5. Supplementary material.")

When performing bulk dump in the advanced edit mode, the TD-5 transmits parameters using one way communications. The TD-5 receives parameters using one way communications while the metronome is stopped, if bulk dump is not performed.

### • Request data

#### RQ1(11H)

This message is sent out when there is a need to acquire data from a device at the other end of the interface. It contains data for the address and size that satisfy the request.

For the address and size of each parameter of the TD-5, refer to 4. Parameter address map.

Byte	Description
F0H	Exclusive status
41H	Manufacturer's ID (Roland)
DEV	Device ID (00H–0FH)
6EH	Model ID (TD-5)
11H	Command ID (RQ1)
aaH	Address MSB
bbH	Address
ccH	Address
ddH	Address LSB
eeH	size MSB
ffH	size
ggH	size
hhH	size LSB
sum	Check sum
F7H	EOX (End of Exclusive)

### • Data set

#### DT1(12H)

This is the message that actually performs data transmission.

For the address and size of each parameter of the TD-5, refer to 4. Parameter address map.

Byte	Description
F0H	Exclusive status
41H	Manufacturer's ID (Roland)
DEV	Device ID (00H–0FH)
6EH	Model ID (TD-5)
12H	Command ID (DT1)
aaH	Address MSB
bbH	Address
ccH	Address
ddH	Address LSB
eeH	data
.	.
.	.
sum	Check sum
F7H	EOX (End of Exclusive)

## 4. Parameter address map

Addresses are shown in every 7-bit hexadecimal.

Address	MSB			LSB
Binary	0aaa aaaa	0bbb bbbb	0ccc cccc	0ddd dddd
7-bit hex.	AA	BB	CC	DD

### § Parameter base addresses

Start Address(H)	Description
00 00 00 00	Patch parameters *4-1
:	:
01 00 00 00	Background instrument parameters *4-2
:	:
02 00 00 00	Trigger parameters *4-3
:	:
03 00 00 00	System set up *4-4

**Table 4-1 Patch parameters**

Address(H)	Size(H)	Data(H)	Parameter	Description
00 pp 00 00	00 00 00 01	00 - 14	Reverb Type	OFF, RM1, RM2, HL1, HL2, PLT, TRE, DL1-DL9, FB1-FB5
00 pp # 00	00 00 00 01	00 - 0D	Inst No. upper4bits	K01 - E18
00 pp # 01	00 00 00 01	00 - 0F	Inst No. lower4bits	
00 pp # 02	00 00 00 01	00 - 0F	Level	0 - 15
00 pp # 03	00 00 00 01	00 - 10	Pan	L7 - CTR - R7, RND, ALT
00 pp # 04	00 00 00 01	2D - 40 - 53	Pitch	-95 - 0 - +95
00 pp # 05	00 00 00 01	21 - 40 - 5F	Decay	-31 - 0 - +31
00 pp # 06	00 00 00 01	00 - 0F	Reverb level	0 - 15

pp: Patch No. 00H - 1FH (patch.1 - patch.32)  
 #t: Trigger No. 01H - 10H (1/KICK - 8/RIDE (RIM) )

Trigger No. is related to the following trigger input.

Trigger No.	Trigger Input
01H	1/KICK
02H	2/SNARE
03H	3/HI-HAT
04H	4/CRASH
05H	5/TOM1
06H	6/TOM2
07H	7/TOM3
08H	8/RIDE
09H	1/KICK (RIM)
0AH	2/SNARE (RIM)
0BH	3/HI-HAT (RIM)
0CH	4/CRASH (RIM)
0DH	5/TOM1 (RIM)
0EH	6/TOM2 (RIM)
0FH	7/TOM3 (RIM)
10H	8/RIDE (RIM)

#### • Example of RQ1

To acquire all 2/SNARE data of patch 1, send the following data to the TD-5. (Basic Channel:10)

FO 41 09 6E 11 00 00 02 00 00 00 00 07 77 F7  
 address size

• **Example of DT1**

To set the level of 2/SNARE of patch 3 to 15, send the following data to the TD-5. (Basic Channel:10)

F0 41 09 6E 12 00 02 02 02 0F 6B F7  
                   address     data

**Table 4-2      Background Inst Parameters**

Address(H)	Size(H)	Data(H)	Parameter	Description
01 00 bb 00	00 00 00 01	00 - 0D	Inst No. upper4bits	K01 - E18
01 00 bb 01	00 00 00 01	00 - 0F	Inst No. lower4bits	
01 00 bb 02	00 00 00 01	00 - 0F	Level	0 - 15
01 00 bb 03	00 00 00 01	00 - 10	Pan	L7 - CTR - R7, RND, ALT
01 00 bb 04	00 00 00 01	2D - 40 - 53	Pitch	-95 - 0 - +95
01 00 bb 05	00 00 00 01	21 - 40 - 5F	Decay	-31 - 0 - +31
01 00 bb 06	00 00 00 01	00 - 0F	Reverb level	0 - 15

bb:      Background Inst No.00H - 2BH (0 - 43)

Background Inst No. corresponds to the note number as shown below.

Background Inst No.	Note Number
00H	1BH(27)
01H	1CH(28)
02H	1DH(29)
03H	1EH(30)
04H	1FH(31)
05H	20H(32)
06H	21H(33)
07H	22H(34)
08H	25H(37)
09H	27H(39)
0AH	36H(54)
0BH	37H(55)
0CH	38H(56)
0DH	39H(57)
0EH	3AH(58)
0FH	3BH(59)
10H	3CH(60)
11H	3DH(61)
12H	3EH(62)
13H	3FH(63)
14H	40H(64)
15H	41H(65)
16H	42H(66)
17H	43H(67)
18H	44H(68)
19H	45H(69)
1AH	46H(70)
1BH	47H(71)
1CH	48H(72)
1DH	49H(73)
1EH	4AH(74)
1FH	4BH(75)
20H	4CH(76)
21H	4DH(77)
22H	4EH(78)
23H	4FH(79)
24H	50H(80)
25H	51H(81)
26H	52H(82)
27H	53H(83)
28H	54H(84)
19H	55H(85)
2AH	56H(86)
2BH	57H(87)

• **Example of RQ1**

To acquire all data of Note No. 64, send the following data to the TD-5.(Basic Channel:10)

```
FO 41 09 6E 11 01 00 14 00 00 00 00 07 64 F7
          address      size
```

• **Example of DT1**

To set the pitch of Note Nos. 80 to 0, send the following data to the TD-5.(Basic channel:10)

```
FO 41 09 6E 12 01 00 24 04 40 17 F7
          address      data
```

**Table 4-3 Trigger Parameters**

Address(H)	Size(H)	Data(H)	Parameter	Description
02 00 # 00	00 00 00 01	00 - 0B	Trigger Type	PD5, PD7, PD9, P1, P2, KD5, K1, K2, KIK, SNR, TOM, FLR
02 00 # 01	00 00 00 01	00 - 0F	Sens	1 - 16
02 00 # 02	00 00 00 01	00 - 0F	Threshold	0 - 15
02 00 # 03	00 00 00 01	00 - 07	Curve	LNR, EP1, EP2, LG1, LG2, SPL, LD1, LD2
02 00 # 04	00 00 00 01	00 - 28	Scan time	0.0 - 4.0
02 00 # 05	00 00 00 01	00 - 0F	Re-trigger cancel	1 - 16
02 00 # 06	00 00 00 01	00 - 10	Mask time	0 - 64
02 00 # 07	00 00 00 01	00 - 06	Xtalk cancel	OFF, 30 - 80

tt: Trigger Input No. 00H - 07H (1/KICK - 8/RIDE)

The relationship between Trigger Input No. and Trigger Input is as follows:

Trigger Input No.	Trigger Input
00H	1/KICK
01H	2/SNARE
02H	3/HI-HAT
03H	4/CRASH
04H	5/TOM1
05H	6/TOM2
06H	7/TOM3
07H	8/RIDE

• **Example of RQ1**

To acquire all 3/HI-HAT data, send the following data to the TD-5. (Basic Channel:10)

```
FO 41 09 6E 11 02 00 02 00 00 00 00 08 74 F7
          address      size
```

• **Example of DT1**

To set 3/HI-HAT trigger type to Pd7, send the following data to the TD-5. (Basic Channel:10)

```
FO 41 09 6E 12 02 00 02 00 01 7B F7
          address      data
```

**Table 4-4 System Setup**

Address(H)	Size(H)	Data(H)	Parameter	Description
03 00 00 00	00 00 00 01	00 - 01	MIDI Sync	OFF, ON
03 00 00 01	00 00 00 01	00 - 03	Program change sw	OFF, RCE, TRS, R-T
03 00 00 02	00 00 00 01	00 - 04	FD-7 control change	FOT, MOD, HLD, GN1, GN2
03 00 00 03	00 00 00 01	00 - 0F	Metronome instrument	VCE - 808
03 00 00 04	00 00 00 01	00 - 0F	Metronome level	0 - 15
03 00 00 05	00 00 00 01	00 - 0F	Metronome Pan	L7 - CTR - R7, PHO
03 00 00 06	00 00 00 01	00 - 0E	Beat Type	1/4 - 7/4, 2/8 - 8/8, TR1 - TR4
03 00 00 07	00 00 00 01	00 - 01	Acoustic trigger parameter sw	OFF, ON

• **Example of RQ1**

To acquire all system setup data, send the following data to the TD-5. (Basic Channel:10)

```
FO 41 09 6E 11 03 00 00 00 00 00 00 08 75 F7
          address      size
```

• **Example of DT1**

To set metronome pan to Pho, send the following data to the TD-5. (Basic Channel:10)

```
FO 41 09 6E 12 03 00 00 05 0F 69 F7
          address      data
```



## 5. Supplementary material

### • Decimal and Hexadecimal table

In MIDI documentation, data values and addresses/sizes of exclusive messages etc. are expressed as hexadecimal values for each 7 bits. The following table shows how these correspond to decimal numbers.

Dec	Hex	Dec	Hex	Dec	Hex	Dec	Hex
0	00H	32	20H	64	40H	96	60H
1	01H	33	21H	65	41H	97	61H
2	02H	34	22H	66	42H	98	62H
3	03H	35	23H	67	43H	99	63H
4	04H	36	24H	68	44H	100	64H
5	05H	37	25H	69	45H	101	65H
6	06H	38	26H	70	46H	102	66H
7	07H	39	27H	71	47H	103	67H
8	08H	40	28H	72	48H	104	68H
9	09H	41	29H	73	49H	105	69H
10	0AH	42	2AH	74	4AH	106	6AH
11	0BH	43	2BH	75	4BH	107	6BH
12	0CH	44	2CH	76	4CH	108	6CH
13	0DH	45	2DH	77	4DH	109	6DH
14	0EH	46	2EH	78	4EH	110	6EH
15	0FH	47	2FH	79	4FH	111	6FH
16	10H	48	30H	80	50H	112	70H
17	11H	49	31H	81	51H	113	71H
18	12H	50	32H	82	52H	114	72H
19	13H	51	33H	83	53H	115	73H
20	14H	52	34H	84	54H	116	74H
21	15H	53	35H	85	55H	117	75H
22	16H	54	36H	86	56H	118	76H
23	17H	55	37H	87	57H	119	77H
24	18H	56	38H	88	58H	120	78H
25	19H	57	39H	89	59H	121	79H
26	1AH	58	3AH	90	5AH	122	7AH
27	1BH	59	3BH	91	5BH	123	7BH
28	1CH	60	3CH	92	5CH	124	7CH
29	1DH	61	3DH	93	5DH	125	7DH
30	1EH	62	3EH	94	5EH	126	7EH
31	1FH	63	3FH	95	5FH	127	7FH

- Decimal values such as MIDI channel and program change are listed as one greater than the values given in the above table.
- A 7-bit byte can express data in the range of 128 steps. For data where greater precision is required, we must use two or more bytes. For example, two hexadecimal numbers aa bbH expressing two 7-bit bytes would indicate a value of aa x 128 + bb.
- In the case of values which have a +/- sign, 00H = -64, 40H = +/- 0, and 7FH = +63, so that the decimal expression would be 64 less than the value given in the above chart. In the case of two types, 00 00H = -8192, 40 00H = +/- 0, and 7F 7FH = +8191. For example if aa bbH were expressed as decimal, this would be aa bbH - 40 00H = aa x 128 + bb - 64 x 128.
- Data marked "nibbled" is expressed in hexadecimal in 4-bit units. A value expressed as a 2-byte nibble 0a 0bH has the value of a x 16 + b.

#### <Example 1>

What is the decimal expression of 5AH ?

>From the preceding table, 5AH = 90

#### <Example 2>

What is the decimal expression of the value 12 34H given as hexadecimal for each 7 bits?

>From the preceding table, since 12H = 18 and 34H = 52  
18 x 128 + 52 = 2356

#### <Example 3>

What is the decimal expression of the nibbled value 0A 03 09 0D ?

>From the preceding table, since 0AH = 10, 03H = 3, 09H = 9, 0DH = 13  
(10 x 16 + 3) x 16 + 9 + 16 + 13 = 41885

#### <Example 4>

What is the nibbled expression of the decimal value 1258?

16}	1258
16}	78 ... 10
16}	4 ... 14
	0 ... 4

Since from the preceding table, 0=00H, 4=04H, 14=0EH, 10=0AH, the answer is 00 04 0E 0AH

### • Examples of actual MIDI messages

#### <Example 1> C9 49

CnH is the Program Change status, and n is the MIDI channel number. Since 9H = 9 and 49H = 73, this is a Program Change message with MIDI CH = 10, program number 74.

### • Example of an Exclusive message and calculating a Checksum

Roland Exclusive messages (RQ1, DT1) are transmitted with a checksum at the end (before F7) to make sure that the message was correctly received. The value of the checksum is determined by the address and data (or size) of the transmitted exclusive message.

How to calculate the checksum (hexadecimal numbers are indicated by 'H')

The checksum is a value derived by adding the address, size and checksum itself and inverting the lower 7 bits.

Here's an example of how the checksum is calculated. We will assume that in the exclusive message we are transmitting, the address is aa bb cc ddH and the data or size is ee ff gg hhH.

aa + bb + cc + dd + ee + ff + gg + hh = sum  
sum + 128 = quotient ... remainder  
128 - remainder = checksum

Example 1: To set the level of 2/SNARE of patch 2 to 10

Because the basic channel is set to 10 ch, the device ID is 09H.

According to parameter Address Map, the address of patch 2, 2/SNARE level is 00 01 02 02H, and 10 equals 0AH, then,

F0	41	09	6E	12	00	01	02	02	0A	??	F7
(1)	(2)	(3)	(4)	(5)	address		data	checksum		(6)	

- (1) Exclusive status
- (2) Manufacturer ID (Roland)
- (3) Device ID (10)
- (4) Model ID (TD-5)
- (5) Command ID (DT1)
- (6) End of exclusive

Next we calculate the checksum.

00H + 01H + 02H + 02H + 0AH = 0 + 1 + 2 + 2 + 10 = 15(sum)  
15(sum) + 128 = 0(quotient) ... 15(remainder)  
checksum = 128 - 15(remainder) = 113 = 71H

This means that F0 41 09 6E 12 00 01 02 02 0A 71 F7 is the message we transmit.

Example 2: To request patch 3, 5/TOM1 pitch data

Because the basic channel is set to 10 ch, the device ID is 09H.

According to Parameter Address Map, the address of Patch 3, 5/TOM1 pitch is 00 02 05 04H, and size is 00 00 00 01H, then,

F0	41	09	6E	11	00	02	05	04	00	00	00	01	??	F7
(1)	(2)	(3)	(4)	(5)	address		size	checksum					(6)	

- (1) Exclusive status
- (2) Manufacturer ID (Roland)
- (3) Device ID (10)
- (4) Model ID (TD-5)
- (5) Command ID (RQ1)
- (6) End of exclusive

Next we calculate the checksum.

00H + 02H + 05H + 04H + 00H + 00H + 00H + 01H = 0 + 2 + 5 + 4 + 0 + 0 + 0 + 1 = 12(sum)  
12(sum) + 128 = 0(quotient) ... 12(remainder)  
checksum = 128 - 12(remainder) = 116 = 74H

This means that F0 41 09 6E 11 00 02 05 04 00 00 00 01 74 F7 is the message we transmit.

# MIDI Implementation Chart

Function...		Transmitted	Recognized	Remarks
Basic Channel	Default Changed	OFF, 1 - 16 OFF, 1 - 16	1 - 16 1 - 16	Memorized (Non-volatile)
Mode	Default Messages Altered	Mode 3 X *****	Mode 3 X	
Note Number :	True Voice	22, 26, 35, 36, 38, 40 - 53 *****	22, 26 - 87	* 1
Velocity	Note ON Note OFF	O 9n v = 1 - 127 O 9n v = 0	O X	
After Touch	Key's Ch's	O 0, 127 X	O 0 - 127 X	
Pitch Bend		X	X	
Control Change	1 4 7 11 16-17 64	X * 2 O * 2 X X X * 2 X * 2	X * 2 O * 2 O O X * 2 X * 2	Modulation Foot Volume Expression General Purpose Controllers 1 - 2 Hold 1
Prog Change	: True #	O * 3 *****	O * 3 0 - 31	
System Exclusive		O	O	
System Common	: Song Pos : Song Sel : Tune	X X X	O MIDI Sync = ON X X	
System Real Time	: Clock : Commands	O MIDI Sync = OFF O MIDI Sync = OFF * 4	O MIDI Sync = ON O MIDI Sync = ON	
Aux Message	: Reset All Controllers : Local ON/OFF : All Notes OFF : Active Sense : Reset	X X X O X	O X X O X	
Notes		* 1 Trigger input vs Note Nos. : common to transmission and receive. * 2 Can select one of these controllers for the FD-7. * 3 Can be set to O or X. * 4 Only Start and Stop.		

Mode 1 : OMNI ON, POLY

Mode 2 : OMNI ON, MONO

O : Yes

Mode 3 : OMNI OFF, POLY

Mode 4 : OMNI OFF, MONO

X : No

---

## 8 Specifications

### TD-5 Percussion Sound Module

**Maximum Polyphony :** 14 voices

**Instruments :** 210

**Patches :** 32

**Sound Parameters :**

Instrument

Level

Pan

Pitch

Decay

Reverb Type

Reverb Level

**Effects :**

Reverb (6 types), Delay (14 types)

**Metronome :**

Beat Type (15 types)

Tempo (40 to 250)

**Display :**

7 segments, 3 characters (LED)

**Pad Indicators :** 8

**Connectors :**

Trigger Input Jacks (Stereo) x 8

Hi-Hat Control Jack

Output Jacks (L(Mono), R)

Headphone Jack (Stereo miniature type)

Patch Shift Jack (Stereo)

MIDI Connectors (In, Out)

AUX In Jack (Stereo miniature type)

**Power Supply :**

AC Adaptor

**Current Draw :**

350mA

**Dimensions :**

218 (W) x 250 (D) x 45 (H) mm

8-5/8 (W) x 9-7/8 (D) x 1-13/16 (H) inches

**Weight :**

1.3kg (excluding AC Adaptor)

2 lbs 14 oz (excluding AC Adaptor)

**Accessories :**

Owner's Manual

AC Adaptor (BRA Series)

Rubber Foot x 4

Screws (M5 x 8) x 4

Screws (M3 x 6) x 2

**Options :**

Pad (PD-7,PD-9,PD-5)

Kick Trigger Unit (KD-7,KD-5)

Hi-Hat Control Pedal (FD-7)

Compact Drum Stand (MDS-7)

Cymbal Holder Set (MDY-7)

Pad Holder (MDH-7)

Footswitch Cable (BOSS:PCS-31)

Rack Mount Adaptor (BOSS:RAD-50)

*\* In the interest of product development, the specifications and/or appearance of this unit are subject to change without prior notice.*

---

---

## 9 Index

<b>A</b>	
Advanced Edit Mode.....	25
AUX IN jack.....	8, 11
<b>B</b>	
Background Instrument.....	34
Beat Type.....	23
Bulk Dump.....	38
Bulk Load.....	39
<b>C</b>	
Channel Messages.....	31
Choke Effect.....	13
Closed Hi-Hat.....	15
Control Change.....	32
Controller Number.....	32
Copying a Patch.....	21
Crosstalk.....	27, 45, 46
Curve.....	28
<b>D</b>	
Decay.....	18
Double Trigger.....	27, 45, 46
Drum Pad.....	9
Drum Trigger.....	27, 44
Dynamics Curve.....	28
<b>E</b>	
Edit button.....	6
Edit Mode.....	16
Exclusive Messages.....	32
<b>F</b>	
FD-7.....	15
FD-7 Control Change.....	37
Floor Tom.....	44
Foot Close.....	15
Foot Open.....	15
Foot Switch.....	14
<b>H</b>	
Hi-Hat Control Pedal.....	15
How to set a Metronome Parameter.....	24
How to set a Trigger Parameter.....	29
How to set an Instrument Parameter.....	17
<b>I</b>	
Initialize.....	41, 48
Instrument.....	17, 72
<b>K</b>	
KD-5.....	9
KD-7.....	9
Kick.....	44
Kick Trigger Unit.....	9
<b>L</b>	
Level.....	18
<b>M</b>	
Mask Time.....	46
Metronome.....	22
Metronome Instrument.....	23
Metronome Level.....	23
Metronome Pan.....	24
MIDI Channel.....	35
MIDI connector.....	30
MIDI Remote.....	40
MIDI Sync.....	35, 42
<b>N</b>	
Note Messages.....	31
Note Number.....	31, 33, 34
<b>O</b>	
Open Hi-Hat.....	15
<b>P</b>	
Pad Indicator.....	6
Pan.....	18
Patch.....	14
Patch Initialize.....	41
Patch Shift jack.....	8, 14
PD-5.....	9
PD-7.....	9, 13
PD-9.....	9, 13
Pho.....	24
Pitch.....	18
Play Mode.....	16
Preview.....	17
Program Change Switch.....	36
Program Number.....	32
<b>R</b>	
Realtime Messages.....	32
Retrigger Cancel.....	46
Reverb Level.....	19
Reverb Type.....	19
Rim Shot.....	13
<b>S</b>	
Scan Time.....	27, 45, 46
Setting the Beat.....	23
Snare Drum.....	44
Sound Parameter.....	16
Sound Parameter button.....	7
Start/Stop button.....	6
System Initialize.....	48
System Messages.....	32
<b>T</b>	
Tempo.....	23
Threshold.....	28
Tom tom.....	44
Trigger Input jack.....	8
Trigger Parameter.....	27
Trigger Sens.....	28
Trigger Type.....	27
<b>V</b>	
Volume knob.....	2, 12

## Information

When you need repair service, call your local Roland Service Station or the authorized Roland distributor in your country as shown below.

### U. S. A.

**Roland Corporation US**  
7200 Dominion Circle  
Los Angeles, CA, 90040-3696, U. S. A.  
TEL: (213) 685 5141

### CANADA

**Roland Canada Music Ltd.**  
(Head Office)  
5480 Parkwood Way  
Richmond B. C., V6V 2M4  
CANADA  
TEL: (604) 270 6626

**Roland Canada Music Ltd.**

(Montreal Office)  
9425 Transcanadienne  
Service Rd. N., St Laurent,  
Quebec H4S 1V3, CANADA  
TEL: (514) 335 2009

**Roland Canada Music Ltd.**

(Toronto Office)  
346 Watline Avenue,  
Mississauga, Ontario L4Z 1X2, CANADA  
TEL: (416) 890 6488

### AUSTRALIA

**Roland Corporation Australia Pty. Ltd.**  
38 Campbell Avenue  
Dee Why West, NSW 2099  
AUSTRALIA  
TEL: (02) 982 8266

### NEW ZEALAND

**Roland Corporation (NZ) Ltd.**  
97 Mt. Eden Road, Mt. Eden,  
Auckland 3, NEW ZEALAND  
TEL: (09) 3098 715

### UNITED KINGDOM

**Roland (U.K.) Ltd.**  
Rye Close Ancells Business  
Park Fleet, Hampshire GU13  
8UY, UNITED KINGDOM  
TEL: (0252) 816181

**Roland (U.K.) Ltd.,  
Swansea Office**

Atlantic Close, Swansea  
Enterprise Park, Swansea,  
West Glamorgan SA79FL,  
UNITED KINGDOM  
TEL: (0792) 700 139

### IRELAND

**The Dublin Service  
Centre Audio  
Maintenance Limited**  
11 Brunswick Place Dublin 2  
Republic of Ireland  
TEL: (01) 677322

### ITALY

**Roland Italy S. p. A.**  
Viale delle Industrie B 20020  
ARESE MILANO ITALY  
TEL: (02) 93581311

### SPAIN

**Roland Electronics de  
España, S. A.**  
Calle Bolivia 239 08020  
Barcelona, SPAIN  
TEL: (93) 308 1000

### GERMANY

**Roland Elektronische  
Musikinstrumente  
Handelsgesellschaft mbH.**  
Oststrasse 96, 22844  
Norderstedt, GFRMANY  
TEL: (040) 52 60090

### FRANCE

**Guillard Musiques  
Roland**  
ZAC de Rosarge Les Echets  
01700  
MIRIBEL FRANCE  
TEL: (72) 26 5060

**Guillard Musiques  
Roland (Paris Office)**

1923 rue Léon Geoffroy  
94400 VITRY-SUR-SEINE  
FRANCE  
TEL: (1) 4680 86 62

### BELGIUM/HOLLAND/ LUXEMBOURG

**Roland Benelux N. V.**  
Houtstraat 1 B-2260 Oevel-  
Westerlo BELGIUM  
TEL: (014) 575811

### DENMARK

**Roland Scandinavia A/S**  
Langebrogade 6 Box 1937  
DK-1023 Copenhagen K,  
DENMARK  
TEL: 31 95 31 11

### SWEDEN

**Roland Scandinavia A/S**  
Danvik Center 28 A, 2 tr.  
S-131 30 Nacka SWEDEN  
TEL: (08) 702 0020

### NORWAY

**Roland Scandinavia Avd.  
Kontor Norge**  
Lilleakerveien 2 Postboks 95  
Lilleaker N-0216 Oslo 2  
NORWAY  
TEL: (02) 73 0074

### FINLAND

**Fazer Musik Inc.**  
Länsituulentie POB 169,  
SF-02101 Espoo FINLAND  
TEL: (00) 43 5011

### SWITZERLAND

**Roland (Switzerland) AG  
Musitronic AG**  
Gerberstrasse 5, CH-4410  
Liestal, SWITZERLAND  
TEL: (061) 921 1615

### AUSTRIA

**E. Dematte & Co.**  
Neu-Rum Siemens-Strasse 4  
A-6040 Innsbruck P.O.Box  
83  
AUSTRIA  
TEL: (0512) 26 44 260

### GREECE

**V. Dimitriadis & Co. Ltd.**  
20, Alexandris Avn., GR  
10682 Athens, GREECE  
TEL: (01) 8232415

### PORTUGAL

**Casa Caius Instrumentos  
Musicais Lda.**  
Rua de Santa Catarina 131  
4000 Porto, PORTUGAL  
TEL: (02) 38 4456

### HUNGARY

**Intermusica Ltd.**  
Warehouse Area 'DEPO'  
Torokbalint, Budapest  
HUNGARY  
TEL: (1) 1868905

### ISRAEL

**D.J.A. International Ltd.**  
Twin Towers, 33 Jabintinsky St.  
Room 211, Ramat Gan 52511  
ISRAEL  
TEL: (03) 751 8585

### CYPRUS

**Radex Sound Equipment  
Ltd.**  
17 Diagorou St., P.O.Box  
2046, Nicosia CYPRUS  
TEL: (2) 453 426  
(2) 466 423

### U.A.E

**Zak Electronics &  
Musical Instruments Co.**  
P.O. Box 8050  
DUBAI, U.A.E  
TEL: 360715

### KUWAIT

**Easa Husain Al-Yousifi**  
P.O. Box 126 Safat 13002  
KUWAIT  
TEL: 5719499

### LEBANON

**A. Chahine & Fils**  
P.O. Box 16-5857  
Beirut, LEBANON  
TEL: (01) 335799

### TURKEY

**Barkat Sanayi ve Ticaret**  
Siraselviler Cad. 86/6 Taksim  
Istanbul, TURKEY  
TEL: (0212) 2499324

### EGYPT

**Al Fanny Trading Office**  
9, Ebn Hagar Ai Askalany  
Street, Ard El Golf,  
Heliopolis, Cairo, 11341  
EGYPT  
TEL: (02) 917 803  
(04) 171 828

### QATAR

**Badie Studio & Stores**  
P.O.Box 62,  
DOHA Qatar  
TEL: 423554

### BAHRAIN

**Moon Stores**  
Bad Al Bahrain Road,  
P.O.Box 20077  
State of Bahrain  
TEL: 211 005

### BRAZIL

**Roland Brasil Ltda.**  
R. Coronel Octaviano da  
Silveira 203 05522-010  
Sao Paulo BRAZIL  
TEL: (11) 843 9377

### MEXICO

**Casa Veerkamp, s.a. de  
c.v.**  
Mesones No. 21 Col. Centro  
MEXICO D.F. 06080  
TEL: (905) 709 3716

**La Casa Wagner de  
Guadalajara s.a. de c.v.**  
Av. Corona No. 202 S.J.  
C.P.44100 Guadalajara,  
Jalisco MEXICO  
TEL: (36) 13 1414

### VENEZUELA

**Musicland Digital C.A.**  
Av. Francisco De Miranda,  
Centro Parque de Cristal,  
Nivel C2 Local 20 Caracas  
VENEZUELA  
TEL: (2) 285 9218

### PANAMA

**Productos Superiores,  
S.A.**  
Apartado 655 - Panama 1  
REP. DE PANAMA  
TEL: 26 3322

### ARGENTINA

**Instrumentos Musicales  
S.A.**  
Florida 638  
(1005) Buenos Aires  
ARGENTINA  
TEL: (1) 394 4029

### HONG KONG

**Tom Lee Music Co., Ltd.  
Service Division**  
22-32 Pun Shan Street, Tsuen  
Wan, New Territories,  
HONG KONG  
TEL: 415 0911

### KOREA

**Cosmos Corporation  
Service Station**  
261 2nd Floor Nak-Won  
Arcade Jong-Ro ku, Seoul,  
KOREA  
TEL: (02) 742 8844

### SINGAPORE

**Swee Lee Company**  
BLOCK 231,  
Bain Street #03-23,  
Bras Basah Complex,  
Singapore 0718  
TEL: 3367886

### PHILIPPINES

**G.A. Yupangco & Co.  
Inc.**  
339 Gil J. Puyat Avenue  
Makati, Metro Manila 1200,  
PHILIPPINES  
TEL: (02) 817 0013

### THAILAND

**Theera Music Co., Ltd.**  
330 Veeng Nakorn Kasem,  
Soi 2, Bangkok 10100,  
THAILAND  
TEL: (02) 2248821

### MALAYSIA

**Bentley Music SDN BHD**  
No.142, Jalan Bukit Bintang  
55100 Kuala Lumpur,  
MALAYSIA  
TEL: (03) 2443333

### INDONESIA

**PT CITRARAMA  
BELANTIKA**  
Kompleks Perkantoran Duta  
Merlin Blok E No.6—7  
Jl. Gajah Mada No.3—5,  
Jakarta 10130,  
INDONESIA  
TEL: (021) 3850073

### TAIWAN

**Siruba Enterprise  
(Taiwan) Co., LTD.**  
Room. 5, 9fl, No. 112 Chung  
Shan N.Road Sec.2 Taipei,  
TAIWAN, R.O.C.  
TEL: (02) 571 5860

### SOUTH AFRICA

**That Other Music Shop  
(PTY) Ltd.**  
11 Melle Street (Cnr Melle  
and Juta Street)  
Braamfontein 2001  
Republic of South Africa  
TEL: (011) 403 4105

### Paul Bothner (PTY) Ltd.

17 Werdmuller Centre  
Claremont 7700  
Republic of South Africa  
TEL: (021) 64 4030

For the U.K.

**IMPORTANT:** THE WIRES IN THIS MAINS LEAD ARE COLOURED IN ACCORDANCE WITH THE FOLLOWING CODE.

BLUE: NEUTRAL  
BROWN: LIVE

As the colours of the wires in the mains lead of this apparatus may not correspond with the coloured markings identifying the terminals in your plug, proceed as follows:

The wire which is coloured BLUE must be connected to the terminal which is marked with the letter N or coloured BLACK.  
The wire which is coloured BROWN must be connected to the terminal which is marked with the letter L or coloured RED.

For Nordic Countries

### Apparatus containing Lithium batteries

#### ADVARSEL!

Lithiumbatteri - Eksplosionsfare ved fejlagtig håndtering.  
Udskiftning må kun ske med batteri af samme fabrikat og type.  
Levér det brugte batteri tilbage til leverandøren.

#### VARNING!

Explosionsfara vid felaktigt batteribyte.  
Använd samma batterityp eller en ekvivalent typ som rekommenderas av apparatillverkaren.  
Kassera använt batteri enligt fabrikantens instruktion.

#### ADVARSEL!

Lithiumbatteri - Eksplosjonsfare.  
Ved utskifting benyttes kun batteri som anbefalt av apparatfabrikanten.  
Brukt batteri returneres apparatleverandøren.

#### VAROITUS!

Paristo voi räjähtää, jos se on virheellisesti asennettu.  
Vaihda paristo ainoastaan laitevalmistajan suosittelemaan tyyppiin. Hävitä käytetty paristo valmistajan ohjeiden mukaisesti.

For Germany

### Bescheinigung des Herstellers/Importeurs

Hiermit wird bescheinigt, daß der/die/das

**PERCUSSION SOUND MODULE TD-5**

(Gerät, Typ, Bezeichnung)

in Übereinstimmung mit den Bestimmungen der BMPT-AmtsblVfg 243/1991 funk-entstört ist. Der vorschriftsmäßige Betrieb mancher Geräte (z. B. Meßsender) kann allerdings gewissen Einschränkungen unterliegen. Beachten Sie deshalb die Hinweise in der Bedienungsanleitung.

Dem Zentralamt für Zulassungen im Fernmeldewesen wurde das Inverkehrbringen dieses Gerätes angezeigt und die Berechtigung zur Überprüfung der Serie auf die Einhaltung der Bestimmungen eingeräumt.

Roland Corporation

4-16 Dojimahama 1-Chome Kita-ku Osaka 530 Japan

(Name und Anschrift des Herstellers/Importeurs)

For the USA

### FEDERAL COMMUNICATIONS COMMISSION RADIO FREQUENCY INTERFERENCE STATEMENT

This equipment has been tested and found to comply with the limits for a Class B digital device, pursuant to Part 15 of the FCC Rules. These limits are designed to provide reasonable protection against harmful interference in a residential installation. This equipment generates, uses, and can radiate radio frequency energy and, if not installed and used in accordance with the instructions, may cause harmful interference to radio communications. However, there is no guarantee that interference will not occur in a particular installation. If this equipment does cause harmful interference to radio or television reception, which can be determined by turning the equipment off and on, the user is encouraged to try to correct the interference by one or more of the following measures:

- Reorient or relocate the receiving antenna.
- Increase the separation between the equipment and receiver.
- Connect the equipment into an outlet on a circuit different from that to which the receiver is connected.
- Consult the dealer or an experienced radio/TV technician for help.

Unauthorized changes or modification to this system can void the users authority to operate this equipment.  
This equipment requires shielded interface cables in order to meet FCC class B Limit.

For Canada

#### CLASS B

#### NOTICE

This digital apparatus does not exceed the Class B limits for radio noise emissions set out in the Radio Interference Regulations of the Canadian Department of Communications.

#### CLASS B

#### AVIS

Cet appareil numérique ne dépasse pas les limites de la classe B au niveau des émissions de bruits radioélectriques fixés dans le Règlement des signaux parasites par le ministère canadien des Communications.



# INSTRUMENT LIST

<b>KICK</b>	S26 L.A.Hard	T20 Room2	P05 CongaComb	PC
K01 Big	S27 L.A.HardAmb	T21 Room3	P06 CongaLowOpen	PC
K02 BigLow	S28 Light	T22 RoomAmb1	P07 CongaHiMute	
K03 BigLowAmb	S29 Loose1	T23 RoomAmb2	P08 CongaHiSlap	
K04 Dance	S30 Loose2	T24 RoomAmb3	P09 Cowbell	PI
K05 Dry	S31 Loreal1	T25 Classic1	P10 Claves	PI
K06 House	S32 Loreal2	T26 Classic2	P11 GuiroLong	
K07 Maple1	S33 Maple	T27 Classic3	P12 GuiroShort	
K08 Maple2	S34 Rockabilly	T28 ClassicAmb1	P13 GuiroLg-Sh	SW
K09 MondoVerb	S35 Rocker	T29 ClassicAmb2	P14 Maracas	PI
K10 MondoVrbAmb	S36 Rockin'	T30 ClassicAmb3	P15 Shaker	PI
K11 Mute	S37 Rockin'Amb	T31 Snapper1	P16 Tambourine1	
K12 Pillow	S38 RockRimShot	T32 Snapper2	P17 Tambourine2	
K13 Rap	S39 RocRmShtAmb	T33 Snapper3	P18 TimbaleHigh	
K14 Real	S40 Ring	T34 BrushSlap1	P19 TimbaleLow	
K15 RealAmb	S41 RingLight	T35 BrushSlap2	P20 Vibra-Slap	
K16 Reverb	S42 Real1	T36 BrushSlap3	P21 Agogo1	
K17 ReverbAmb	S43 Real2	T37 TR-808	P22 Agogo2	SW
K18 Room1	S44 Reggae		P23 Cabasa	
K19 Room1Amb	S45 Rock1	<b>HI-HAT</b>	P24 CuicaMute	SW
K20 Room2	S46 Rock1Amb	H01 Groovy1	P25 CuicaOpen	
K21 Solid	S47 Rock2	H02 Groovy2	P26 WhistleLong	
K22 SolidAmb	S48 Roll	H03 Rock1	P27 WhistleShort	
K23 VerbSolid	S49 Tambrn!	H04 Rock2	P28 WhistleLg-Sh	SW
K24 VrbSolidAmb	S50 Tight	H05 Real1	P29 TriangleMute	
K25 Wood	S51 TR-808	H06 Real2	P30 TriangleOpen	PC
K26 TR-808	S52 TR-909	H07 RockLight	P31 TriMute-Open	SW
K27 TR-909	S53 BrushRoll	H08 Bright	P32 WoodBlock1	PI
K28 909Hard	S54 BrushSlap1	H09 Radio	P33 WoodBlock2	
	S55 BrushSlap2	H10 Unber	P34 TalkingDrum	PC
<b>SNARE</b>	S56 BrushSwish	H11 Brush	P35 Taiko	PC
S01 Dynamic1	S57 BrushComb	H12 TR-808	P36 TR-808Clap1	
S02 Dynamic1Amb	S58 Side Stick	<b>CYMBAL</b>	P37 TR-808Clap2	
S03 Dynamic2	S59 Hall Stick	C01 Crash1	P38 808Cowbell1	
S04 Acoustic1	S60 MassiveStik	C02 Crash2	P39 808Cowbell2	
S05 Acoustic2		C03 Crash3		
S06 Attack	<b>TOM TOM</b>	C04 Crash4	<b>EFFECT</b>	
S07 Bong	T01 Dynamic1	C05 Crash-Crash	E01 Snaps	
S08 Bounce	T02 Dynamic2	C06 Splash-Crash	E02 Ti-Ta	SW
S09 BounceAmb	T03 Dynamic3	C07 Crash-Swell	E03 Asiantones	PC
S10 Chipper	T04 DynamicAmb1	C08 Chinese1	E04 Trimsine	PC
S11 Clap!	T05 DynamicAmb2	C09 Chinese2	E05 Major	
S12 Dance1	T06 DynamicAmb3	C10 Splash	E06 Noise1	
S13 Dance2	T07 Real1	C11 Ride	E07 Noise2	
S14 Dopin'1	T08 Real2	C12 RideBell	E08 Bomb	
S15 Dopin'2	T09 Real3	C13 Ride-RdBell	E09 Metal	
S16 Fat	T10 RealAmb1	C14 SizzleRide	E10 MetalStick	
S17 Hip	T11 RealAmb2	C15 BrushRide	E11 Random1	PC
S18 House	T12 RealAmb3	C16 TR-808	E12 Random2	PC
S19 HouseDopin'	T13 Dry1	<b>PERCUSSION</b>	E13 Random3	PC
S20 Hard	T14 Dry2	P01 BongoHigh	E14 Falldown	
S21 HardAmb	T15 Dry3	P02 BongoLow	E15 ReverseKick	
S22 HardRock	T16 Rock1	P03 BongoLo-Hi	E16 ReverseSnare	
S23 L.A.Fat1	T17 Rock2	P04 CongaHOP-HMt	E17 ReverseCymbal	
S24 L.A.Fat1Amb	T18 Rock3		E18 ReverseAmb	
S25 L.A.Fat2	T19 Room1			

\* The sound of the KICK (K01 and after), SNARE (S01 and after), TOM (t01 and after), and HI-HAT (H01 and after) Instruments changes depending on how hard you strike the Pad.

\* "SW": The Instrument changes depending on how hard the Pad is struck.

\* "HH": The Hi-hat can be opened and closed by operating the Hi-hat Control Pedal.

\* "PC": The sound can be changed by operating the Hi-hat Control Pedal.

\* "PI": Pressing the Hi-hat Control Pedal sounds the Instrument.

\* "HH," "PC," and "PI" are effective only when the respective Instrument is assigned to the Pad connected to "INPUT 3/HI-HAT."

**Roland**<sup>®</sup>



## TD-5新規パッチ・リストの紹介

### Introducing New Patches for the TD-5

次のように、すべてのパッチを新規に作成しました。TD-5の取扱説明書に記載されているパッチに切り替えることはできません。

All the Patches have been newly created. Please see the new list that follows.

The Patches shown in the TD-5 Owner's Manual cannot be selected.

Patch #	Patch Name	Patch #	Patch Name	Patch #	Patch Name	Patch #	Patch Name
1	Rocker	9	Brushes	17	Clean	25	Stomp It
2	Live	10	UZable	18	Big Room	26	March
3	Street	11	Eura	19	Reggae	27	Soft
4	Dry	12	Ate O Ate	20	Percussion 1	28	Lefty
5	Reverb	13	Space	21	Jazzy	29	Rand@Alt
6	Delay	14	Z Led	22	Metal	30	Cross Stick
7	Perkus'n	15	Tremolo	23	Grunge	31	Fusion
8	Alley	16	Pubelle	24	Piccolo Spread	32	Slidin'

また、次ページからの表は、各パッチのパッドに割り当てられているインストゥルメントです。

The following tables show the instruments assigned to the Pads for each Patch.

#### PD-120/PD-100に対応

別売のパッドPD-120/PD-100を接続する場合は、以下のようにトリガー・パラメーターを設定することをお勧めします (TD-5取扱説明書、P.27)。

	トリガー・ タイプ	トリガー・ センス	トリガー・ スレッシュホールド	トリガー・ カーブ
PD-120	Pd7	3	2	Lnr
PD-100	Pd7	3	2	Lnr

- ※ TD-5では打点位置の検出はできません。
- ※ TD-5にPD-120/PD-100を接続する際は、必ずモノラル・ケーブルを使用してください。
- ※ PD-120/PD-100ではリム・ショットはできません。

#### Compatible with the PD-120/PD-100

To use an optional PD-120/PD-100 pad, we recommend that you set the trigger parameters as follows (TD-5 Owner's Manual, p. 27).

	TRIGGER TYPE	TRIGGER SENS	TRIGGER THRESHOLD	TRIGGER CURVE
PD-120	Pd7	3	2	Lnr
PD-100	Pd7	3	2	Lnr

- \* The TD-5 can't detect hitting positions.
- \* When connecting the PD-120/PD-100 to the TD-5, be sure to use a monaural cable.
- \* The Rim Shot effect cannot be obtained using the PD-120/PD-100.

PATCH# PATCH NAME	1. Rocker	2. Live	3. Street	4. Dry
REVERB TYPE	oFF OFF	HL1 Hall1	rM2 Room2	oFF OFF
1/KICK	K08 Maple2	K21 Solid	K13 Rap	K07 Maple1
1/KICK (rim)	K08 Maple2	K21 Solid	K13 Rap	K07 Maple1
2/SNARE	S03 Dynamic2	S26 L.A.Hard	S19 HouseDopin'	S04 Acoustic1
2/SNARE (rim)	S38 RockRimShot	S38 RockRimShot	S18 House	S33 Maple
3/HI-HAT	H01 Groovy1	H04 Rock2	H08 Bright	H07 RockLight
3/HI-HAT (rim)	H01 Groovy1	H04 Rock2	H08 Bright	H07 RockLight
4/CRASH	C05 Crash-Crash	C08 Chinese1	C12 RideBell	C02 Crash2
4/CRASH (rim)	C08 Chinese1	C08 Chinese1	C10 Splash	C10 Splash
5/TOM1	T01 Dynamic1	T16 Rock1	T34 BrushSlap1	T07 Real1
5/TOM1 (rim)	T01 Dynamic1	T16 Rock1	P02 BongoLow	T25 Classic1
6/TOM2	T02 Dynamic2	T17 Rock2	T35 BrushSlap2	T08 Real2
6/TOM2 (rim)	T02 Dynamic2	T17 Rock2	P04 CongaHOp-HMt	T26 Classic2
7/TOM3	T03 Dynamic3	T18 Rock3	T36 BrushSlap3	T09 Real3
7/TOM3 (rim)	T03 Dynamic3	T18 Rock3	P16 Tambourine1	T27 Classic3
8/RIDE	C13 Ride-RdBell	C13 Ride-RdBell	C13 Ride-RdBell	C13 Ride-RdBell
8/RIDE (rim)	C12 RideBell	C12 RideBell	P16 Tambourine1	C12 RideBell

PATCH# PATCH NAME	5. Reverb	6. Delay	7. Perkus'n	8. Alley
REVERB TYPE	HL1 Hall1	Fb4 Feedback Delay4	PLt Plate	oFF OFF
1/KICK	K09 MondoVerb	K23 VerbSolid	P34 TalkingDrum	K04 Dance
1/KICK (rim)	K24 VrbSolidAmb	K25 Wood	P34 TalkingDrum	K04 Dance
2/SNARE	S23 L.A.Fat1	S28 Light	P34 TalkingDrum	S11 Clap!
2/SNARE (rim)	S25 L.A.Fat2	S09 BounceAmb	P23 Cabasa	S15 Dopin'2
3/HI-HAT	H05 Real1	H02 Groovy2	P30 TriangleOpen	H04 Rock2
3/HI-HAT (rim)	H05 Real1	H02 Groovy2	P32 WoodBlock1	H07 RockLight
4/CRASH	C02 Crash2	C02 Crash2	P28 WhistleLg-Sh	C16 TR-808
4/CRASH (rim)	C09 Chinese2	C01 Crash1	C10 Splash	C02 Crash2
5/TOM1	T07 Real1	T25 Classic1	P19 TimbaleLow	E07 Noise2
5/TOM1 (rim)	T10 RealAmb1	T07 Real1	S58 Side Stick	E07 Noise2
6/TOM2	T08 Real2	T26 Classic2	P04 CongaHOp-HMt	E07 Noise2
6/TOM2 (rim)	T11 RealAmb2	T08 Real2	S58 Side Stick	E07 Noise2
7/TOM3	T09 Real3	T27 Classic3	P35 Taiko	E07 Noise2
7/TOM3 (rim)	T12 RealAmb3	T09 Real3	P35 Taiko	E07 Noise2
8/RIDE	C13 Ride-RdBell	C11 Ride	P16 Tambourine1	C14 SizzleRide
8/RIDE (rim)	C12 RideBell	C12 RideBell	P17 Tambourine2	C09 Chinese2

PATCH# PATCH NAME	9. Brushes	10. UZable	11. Eura	12. Ate O Ate
REVERB TYPE	rM1 Room1	HL2 Hall2	Fb3 Feedback Delay3	oFF OFF
1/KICK	K07 Maple1	K07 Maple1	K27 TR-909	K26 TR-808
1/KICK (rim)	K07 Maple1	K07 Maple1	K06 House	K26 TR-808
2/SNARE	S53 BrushRoll	S17 Hip	S12 Dance1	S51 TR-808
2/SNARE (rim)	S54 BrushSlap1	S43 Real2	S13 Dance2	P36 TR-808Clap1
3/HI-HAT	H11 Brush	H10 Unber	P30 TriangleOpen	H12 TR-808
3/HI-HAT (rim)	H11 Brush	H10 Unber	P30 TriangleOpen	H12 TR-808
4/CRASH	C07 CrashSwell	C05 Crash-Crash	C11 Ride	C16 TR-808
4/CRASH (rim)	C03 Crash3	C03 Crash3	C08 Chinese1	C16 TR-808
5/TOM1	T34 BrushSlap1	T19 Room1	E03 Asiantones	T37 TR-808
5/TOM1 (rim)	T34 BrushSlap1	T19 Room1	E03 Asiantones	P39 808Cowbell2
6/TOM2	T35 BrushSlap2	T20 Room2	E03 Asiantones	T37 TR-808
6/TOM2 (rim)	T35 BrushSlap2	T20 Room2	E03 Asiantones	P39 808Cowbell2
7/TOM3	T36 BrushSlap3	T21 Room3	E03 Asiantones	T37 TR-808
7/TOM3 (rim)	T36 BrushSlap3	T21 Room3	E03 Asiantones	P39 808Cowbell2
8/RIDE	C11 Ride	C13 Ride-RdBell	E02 Ti-Ta	C14 SizzleRide
8/RIDE (rim)	C14 SizzleRide	C12 RideBell	E02 Ti-Ta	C12 RideBell

<u>PATCH# PATCH NAME</u>	<u>13. Space</u>	<u>14. Z Led</u>	<u>15. Tremolo</u>	<u>16. Pubelle</u>
REVERB TYPE	rM2 Room2	HL1 Hall1	trE Tremolo Reverb	Fb5 Feedback Delay5
1/KICK	P35 Taiko	K10 MondoVrbAmb	K20 Room2	K04 Dance
1/KICK (rim)	K27 TR-909	K09 MondoVerb	K11 Mute	K28 909Hard
2/SNARE	S07 Bong	S47 Rock2	S49 Tambnrn!	E09 Metal
2/SNARE (rim)	P34 TalkingDrum	S22 HardRock	S42 Real1	E12 Random2
3/HI-HAT	E13 Random3	H04 Rock2	H10 Unber	E13 Random3
3/HI-HAT (rim)	H12 TR-808	H03 Rock1	H10 Unber	E10 MetalStick
4/CRASH	E04 Trimsine	C02 Crash2	C04 Crash4	E13 Random3
4/CRASH (rim)	P20 Vibra-Slap	C09 Chinese2	C01 Crash1	E08 Bomb
5/TOM1	P38 808Cowbell1	T25 Classic1	T25 Classic1	T37 TR-808
5/TOM1 (rim)	P39 808Cowbell2	T25 Classic1	T25 Classic1	T13 Dry1
6/TOM2	P38 808Cowbell1	T26 Classic2	T26 Classic2	P09 Cowbell
6/TOM2 (rim)	P39 808Cowbell2	T26 Classic2	T26 Classic2	T13 Dry1
7/TOM3	P38 808Cowbell1	T27 Classic3	T27 Classic3	E08 Bomb
7/TOM3 (rim)	P38 808Cowbell1	T27 Classic3	T27 Classic3	E08 Bomb
8/RIDE	E12 Random2	C13 Ride-RdBell	C11 Ride	E12 Random2
8/RIDE (rim)	E12 Random2	C12 RideBell	C07 CrashSwell	E10 MetalStick
<u>PATCH# PATCH NAME</u>	<u>17. Clean</u>	<u>18. Big Room</u>	<u>19. Reggae</u>	<u>20. Percussion 1</u>
REVERB TYPE	oFF OFF	rM2 Room2	rM2 Room2	rM1 Room1
1/KICK	K12 Pillow	K22 SolidAmb	K08 Maple2	P35 Taiko
1/KICK (rim)	K12 Pillow	K22 SolidAmb	K11 Mute	P35 Taiko
2/SNARE	S28 Light	S04 Acoustic1	S41 RingLight	P19 TimbaleLow
2/SNARE (rim)	S31 Loreal1	S21 HardAmb	S42 Real1	P10 Claves
3/HI-HAT	H03 Rock1	H02 Groovy2	H08 Bright	P03 BongoLo-Hi
3/HI-HAT (rim)	H01 Groovy1	H02 Groovy2	H03 Rock1	P05 CongaComb
4/CRASH	C02 Crash2	C02 Crash2	P26 WhistleLong	P13 GuiroLg-Sh
4/CRASH (rim)	C02 Crash2	C09 Chinese2	C09 Chinese2	C10 Splash
5/TOM1	T25 Classic1	T04 DynamicAmb1	P18 TimbaleHigh	P04 CongaHOP-HMt
5/TOM1 (rim)	T25 Classic1	T04 DynamicAmb1	P18 TimbaleHigh	P07 CongaHiMute
6/TOM2	T26 Classic2	T05 DynamicAmb2	P19 TimbaleLow	P05 CongaComb
6/TOM2 (rim)	T26 Classic2	T05 DynamicAmb2	P19 TimbaleLow	P08 CongaHiSlap
7/TOM3	T27 Classic3	T06 DynamicAmb3	P20 Vibra-Slap	P06 CongaLowOpen
7/TOM3 (rim)	T27 Classic3	C06 Splash-Crash	T27 Classic3	P08 CongaHiSlap
8/RIDE	C11 Ride	C13 Ride-RdBell	C10 Splash	P22 Agogo2
8/RIDE (rim)	C12 RideBell	C01 Crash1	C12 RideBell	P21 Agogo1
<u>PATCH# PATCH NAME</u>	<u>21. Jazzy</u>	<u>22. Metal</u>	<u>23. Grunge</u>	<u>24. Piccolo Spread</u>
REVERB TYPE	PLt Plate	HL1 Hall1	rM1 Room1	PLt Plate
1/KICK	K05 Dry	K03 BigLowAmb	K20 Room2	K22 SolidAmb
1/KICK (rim)	K05 Dry	K10 MondoVrbAmb	K10 MondoVrbAmb	K05 Dry
2/SNARE	S30 Loose2	S04 Acoustic1	S10 Chipper	S41 RingLight
2/SNARE (rim)	S29 Loose1	S27 L.A.HardAmb	S10 Chipper	S29 Loose1
3/HI-HAT	H02 Groovy2	H03 Rock1	H06 Real2	H02 Groovy2
3/HI-HAT (rim)	H02 Groovy2	H03 Rock1	H09 Radio	H02 Groovy2
4/CRASH	C05 Crash-Crash	C01 Crash1	E14 Falldown	C05 Crash-Crash
4/CRASH (rim)	C02 Crash2	C08 Chinese1	P39 808Cowbell2	C05 Crash-Crash
5/TOM1	T13 Dry1	T16 Rock1	S17 Hip	T13 Dry1
5/TOM1 (rim)	T13 Dry1	T16 Rock1	P37 TR-808Clap2	T13 Dry1
6/TOM2	T14 Dry2	T17 Rock2	S17 Hip	T14 Dry2
6/TOM2 (rim)	T14 Dry2	T17 Rock2	P19 TimbaleLow	T14 Dry2
7/TOM3	T15 Dry3	T18 Rock3	S17 Hip	T15 Dry3
7/TOM3 (rim)	T15 Dry3	T18 Rock3	P19 TimbaleLow	T15 Dry3
8/RIDE	C13 Ride-RdBell	C14 SizzleRide	E04 Trimsine	C13 Ride-RdBell
8/RIDE (rim)	C12 RideBell	C12 RideBell	E04 Trimsine	C12 RideBell

PATCH#	PATCH NAME	25. Stomp It	26. March	27. Soft	28. Lefty
REVERB TYPE		rM2 Room2	HL1 Hall1	rM2 Room2	PLt Plate
1/KICK		K03 BigLowAmb	T15 Dry3	K11 Mute	K08 Maple2
1/KICK (rim)		E08 Bomb	K14 Real	K18 Room1	K27 TR-909
2/SNARE		E09 Metal	S48 Roll	S04 Acoustic1	S41 RingLight
2/SNARE (rim)		E13 Random3	S29 Loose1	S35 Rocker	S47 Rock2
3/HI-HAT		H03 Rock1	H03 Rock1	H05 Real1	H01 Groovy1
3/HI-HAT (rim)		H01 Groovy1	H03 Rock1	H06 Real2	H08 Bright
4/CRASH		E14 Falldown	C02 Crash2	C05 Crash-Crash	C13 Ride-RdBell
4/CRASH (rim)		C01 Crash1	C10 Splash	C08 Chinese1	C02 Crash2
5/TOM1		E18 ReverseAmb	T13 Dry1	T10 RealAmb1	T15 Dry3
5/TOM1 (rim)		E18 ReverseAmb	T13 Dry1	T19 Room1	T15 Dry3
6/TOM2		E16 ReverseSnare	T14 Dry2	T11 RealAmb2	T14 Dry2
6/TOM2 (rim)		E16 ReverseSnare	T14 Dry2	T20 Room2	T14 Dry2
7/TOM3		E14 Falldown	T15 Dry3	T12 RealAmb3	T13 Dry1
7/TOM3 (rim)		T27 Classic3	T15 Dry3	T21 Room3	T15 Dry3
8/RIDE		P24 CuicaMute	C13 Ride-RdBell	C13 Ride-RdBell	C08 Chinese1
8/RIDE (rim)		P30 TriangleOpen	C12 RideBell	C12 RideBell	C16 TR-808
PATCH#	PATCH NAME	29. Rand@Alt	30. Cross Stick	31. Fusion	32. Slidin'
REVERB TYPE		HL1 Hall1	oFF OFF	rM1 Room1	HL1 Hall1
1/KICK		K15 RealAmb	K05 Dry	K07 Maple1	E07 Noise2
1/KICK (rim)		K15 RealAmb	K05 Dry	K25 Wood	K26 TR-808
2/SNARE		S01 Dynamic1	S58 Side Stick	S32 Loreal2	E06 Noise1
2/SNARE (rim)		P18 TimbaleHigh	S33 Maple	S25 L.A.Fat2	E02 Ti-Ta
3/HI-HAT		H10 Unber	H07 RockLight	H05 Real1	E12 Random2
3/HI-HAT (rim)		H10 Unber	H07 RockLight	H05 Real1	E03 Asiantones
4/CRASH		C05 Crash-Crash	C06 Splash-Crash	C02 Crash2	E14 Falldown
4/CRASH (rim)		C01 Crash1	C02 Crash2	C10 Splash	C09 Chinese2
5/TOM1		T13 Dry1	T07 Real1	T07 Real1	E04 Trimsine
5/TOM1 (rim)		C03 Crash3	T07 Real1	T07 Real1	E04 Trimsine
6/TOM2		T14 Dry2	T08 Real2	T08 Real2	P38 808Cowbell1
6/TOM2 (rim)		C10 Splash	T08 Real2	T08 Real2	P39 808Cowbell2
7/TOM3		P09 Cowbell	T09 Real3	T09 Real3	E14 Falldown
7/TOM3 (rim)		P09 Cowbell	T09 Real3	T09 Real3	E14 Falldown
8/RIDE		H08 Bright	C13 Ride-RdBell	C13 Ride-RdBell	E11 Random1
8/RIDE (rim)		C01 Crash1	C12 RideBell	C12 RideBell	E05 Major



 Roland®

---

71451667

UPC

71451667



1898.

**Roland**