

Roland

DIRECTOR-S

SEQUENCER PACKAGE
SYS-553/SYS-333

Owner's Manual

for S-550 / S-330

The DIRECTOR-S "SYS-553/333" software package changes your Roland S-550/330 Digital Sampler into a 16-channel MIDI sequencer featuring a 16 voice sampling module.

All you have to do is insert the new system disk SYS-553 in the disk drive of your S-550 and the SYS-333 disk in the S-330.

FEATURES

- Easy-to-use software that provides continued access to all existing high quality sound libraries for the S-550/330, yet adds an entirely new range of musical possibilities to your S-550/330.
- The S-550 can read up to two disks of sound data plus 35,000 steps of song data in memory, while the S-330 can store one disk of sound data plus 15,000 steps of song data.
- The system (Song) disk can store up to 100,000 steps of song data.
- The "chain play" function allows you to automatically play back several songs in succession from the S-550/330 memory.
- Complete facility for editing notes and all other types of MIDI events.
- Instant access to the latest in electronic sequencer functions - PUNCH IN, PUNCH OUT, quantizing, and gate time adjustment, for example.
- Synchronized playback with other sequencers, drum machines, and other MIDI equipment.
- Rapid access to sound data editing, as well as to song data programming or editing.
- A detailed display that presents all relevant data in an easy-to-read form so that editing will be easier and faster.
- Using the Mouse MU-1 (which is supplied with the S-550 and optional for the S-330), or the remote controller RC-100 (optional), operation will be quicker.

CRT Display

This software requires a CRT display. If you have a color monitor (explained on page 12 in the S-550 owner's manual and page 11 in the S-330)

Labels for the INC and DEC buttons

When the cursor resides in a screen, the DEC/NO and INC/YES buttons function exactly like the left and right buttons on the Mouse. (How they currently function is shown at the upper right of the Display.) Basically speaking, the button on the left (DEC/NO button) "selects" or "executes", and the button on the right (INC/YES button) "cancels". Therefore, to avoid operational confusion, apply DEC label to the DEC/NO letters, and INC label to the INC/YES letters.

Indicates the functions of the left-side button on the mouse and the DEC button

Indicates the functions of the right-side button on the mouse and the INC button

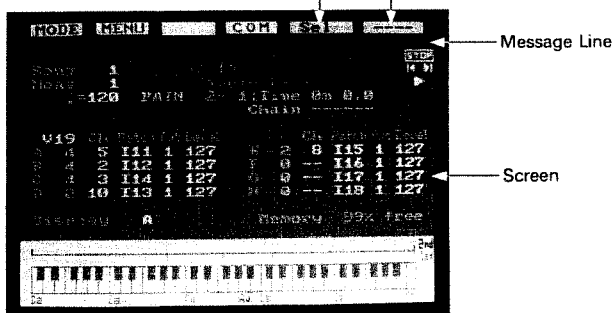

Owner's Key

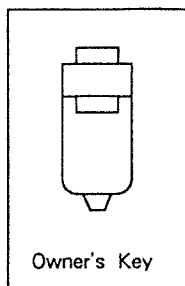

Your owner's key is necessary for the functions "Format", "Save Song", "Save SYS", "Diskcopy" and "Transfer". The Display opens a command window indicating "Check Owner's Key".

When using the panel controls on the S-550/330 or the Mouse, plug the owner's key into the EXT CTRL socket at the front of the S-550/330, then push the EXECUTE button.

When using the RC-100, connect the owner's key to the EXT CTRL socket at the rear of the RC-100, then push the EXECUTE button on the S-550/330 or RC-100.

Take care of it. If you lose it, these important function will not be available.

If you use the System Ver.1.0 with the S – 550

When the S – 550 is booted with your system disk, the CRT display shows “S – 550 System Ver. 1.* *” which is the version number. The “Change SYS” function (that is the function that change the DIRECTOR – S system in the S – 550’s memory to the S – 550 system) cannot be obtained on disks with version number 1.00 to 1.09.

You need to boot up the S – 550 using the utility disk supplied with the DIRECTOR – S, then execute “Save SYS” (see page 142 in the S – 550 owner’s manual) on all the S – 550 disks you have. Here, do not use the supplied utility disk, but use the DIRECTOR – S Utility Disk.

By updating the S – 550 system from Ver.1.0 to Ver.1.1, various functions are added or improved ; read the supplied “Supplementary Explanation for the S – 550 Ver.1.1”.

Caring for Your Floppy Disks

Although your 3.5 – inch floppy disks hard protective cases, the actual recording medium is a thin coating of magnetic material on a flimsy plastic disk, and the recording density is very high. To prevent irretrievable loss of your valuable data, always handle your disks with the proper care.

- Never open the shutter and touch the magnetic film inside. The oil from a fingerprint is sufficient to interfere with proper recording and playback.
- Avoid dusty and smoky environments . Any airborne particulate matter that lands on the surface of the disk risks scratches that can lead to irretrievable loss of data.
- Keep the disk away from strong magnetic fields – TV sets, speakers, and even CRTs, for example.
- Do not store at temperatures outside the 5 – 50°C (41 – 122 ° F) range. Do not, for example, leave in direct sunlight or in a locked car on a clear, hot day.

TABLE OF CONTENTS

1. INTRODUCTION	7	7. EDITING PATTERN DATA	66
1. How to use this Owner's Manual	7	1. Copy	66
2. Three Supplied Disks	8	2. Delete	68
3. Sequencer and Sound Sources	9	3. Transpose	69
4. Creating Song Data	10	4. Change Velocity	70
5. Playing a Song	11	5. Change MIDI Channels	72
6. Saving and Loading Data	11	8. SONG WRITE	73
7. Standard Operation	12	1. Pattern Set	73
2. PREPARING TO PLAY	17	2. Play in the set Screen	75
1. Connections	17	3. Song Clear	75
2. Booting	20	4. Song Name	76
3. Backing Up the DIRECTOR-S System Disk	22	9. EDITING THE ENTIRE DATA	77
4. Loading Song Data and Sound Data	25	1. Delete	78
3. SONG PLAY	29	2. Transpose	79
1. Playing a Song	30	3. Change Velocity	80
2. Function Data set in the Play Mode	32	4. Change MIDI Channels	81
3. Song Mode Screens	35	10. DISK COMMANDS	82
4. PATTERN PLAY	38	1. Format	82
1. Playing Patterns	39	2. Save Song	84
5. MICROSCOPE	42	3. Load Song	85
1. Screen Layout	42	4. Delete Song	86
2. Data Selection	44	5. Save System	87
3. Modifying Data in the Microscope Screen	46	6. Change System	88
6. RECORDING PATTERN DATA	50	7. Disk Transfer	89
1. Recording Concept of the DIRECTOR-S	50	11. OTHER FUNCTIONS	92
2. Preparing to Record	52	1. Chain Play	92
a. Specifying the Sound Source	52	2. Time Calculation	93
b. Clearing Data	53	3. MIDI SYNC Clock	94
c. MIDI Switches	56	12. APPENDIX	
d. Recording Switches	57	Recording MC - 500 Data	96
e. Metronome	58	MIDI IMPLEMENTATION	100
f. Specifying the Time Scale	59	INDEX	104
g. Pattern Mode Parameters	62	SPECIFICATIONS	106
3. Recording	64		

1. INTRODUCTION

1. How to use this Owner's Manual

DIRECTOR – S can edit or modify the sound data of the S – 550/330 as well as create song data. This manual mainly explains creating song data and playing it. Read the owner's manual of the S – 550/330 for editing or modifying sound data.

MODE	MENU	DESCRIPTION	S – 550 page	S – 330 page	This Owner's Manual page
PLAY	Keyboard	Song Play	–	–	29~35
	Patch Disp	Setting Performance	–	–	36
	Mute Play	Controlling Functions	–	–	36
	Tone Map		–	–	37
EDIT	Patch PRM	Editing or Modifying Sound Data	99	99	–
	Split		105	105	–
	Patch Map		109	109	–
	Tone PRM		70	70	–
	Loop		75	75	–
	LFO		82	82	–
	TVF		86	86	–
	TVA		92	92	–
	Tone Map		96	96	–
	Delete		63	63	–
	Copy * Move		65	65	–
Disp Wave	67	67	–		
DISK	Load Song	Data Transfer with Floppy Disk	–	–	25, 26, 35
	Load Sound		122	122	25, 27
	Load Tone		128	126	–
	Dir Patch		130	128	–
	Dir Tone		130	128	–
	Label Set		132	130	–
	Save Song		–	–	84
	Save Sound		133	131	–
	Del Song		–	–	86
	Format		–	–	82
	Save Sys		–	–	87
Change SYS	–	–	88		
FUNC	Master	Changing the S – 550/330 Master Tune and Controller Assignment	111	111	–
	Initialize		114	114	–
MIDI	Message	Setting MIDI Functions of Sound Data	117	117	–
	Prog #		119	119	–
TOOL	Time calc	Time Calculation and Copying Song Data	–	–	93
	Diskcopy		–	–	22
	Transfer		–	–	89
PTRN	Standard	Writing Pattern Data	–	–	38~41
	Microscope		–	–	42~49
SONG	Song Write	Creating Song Data	–	–	73
	Song Name		–	–	76
	Song PRM		–	–	56, 57, 58
	Initialize		–	–	53, 60, 75

2. Three Supplied Disks

Three disks are supplied with the SYS-553/333 "DIRECTOR-S" software package.

*The sound disk does not contain the system program, and therefore cannot boot up the S-550/330. To make the sound disk ready for booting, you may boot the S-550/330 with the supplied utility disk, then execute "Save SYS" (explained on page 142 in the S-550 owner's manual and page 138 in the S-330) on the sound disk.

DIRECTOR-S System Disk (Song Disk)

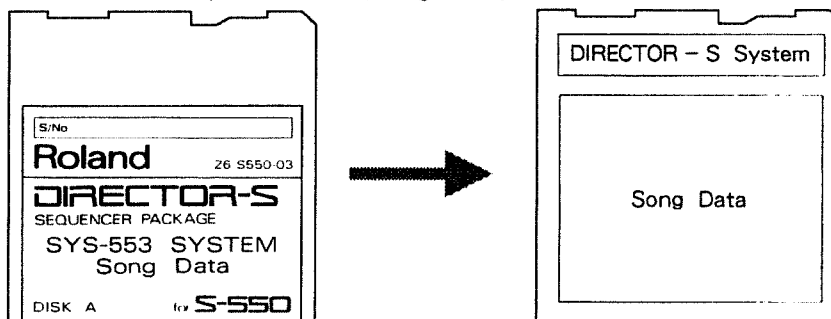

Sound Disk

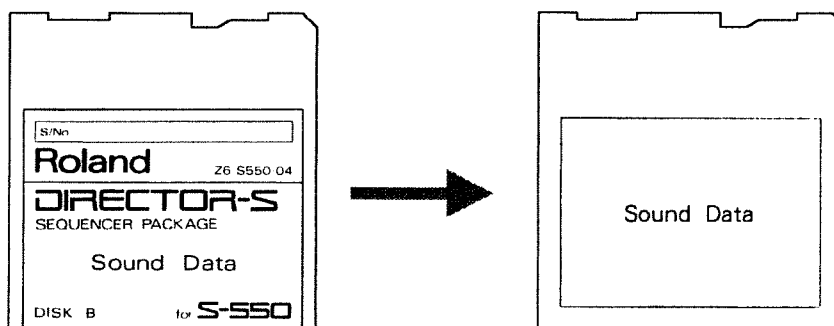

Utility Disk

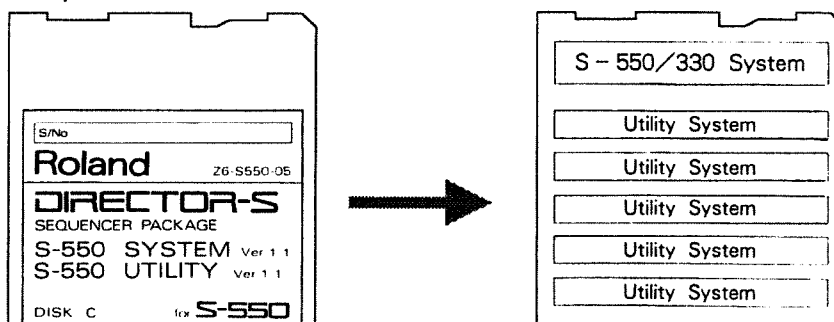

3. Sequencer and Sound Sources

DIRECTOR-S is a new system software that changes your S-550/330 into a multi-channel MIDI sequencer capable of controlling other electronic musical instruments connected using 16 MIDI channels. The software also provides regular access to the sound sources built into the S-550/330. Moreover, the S-550/330's built-in sound sources can be controlled by MIDI messages on eight different channels. This means that even more external MIDI devices can be controlled.

The S-550/330's internal sound module and sequencer can be considered to be connected with MIDI cables as shown below. During recording, the sequencer records the received information, and the received information plays the sound sources of the matching MIDI channel. During playing, the sequencer transmits data which plays the relevant sound sources.

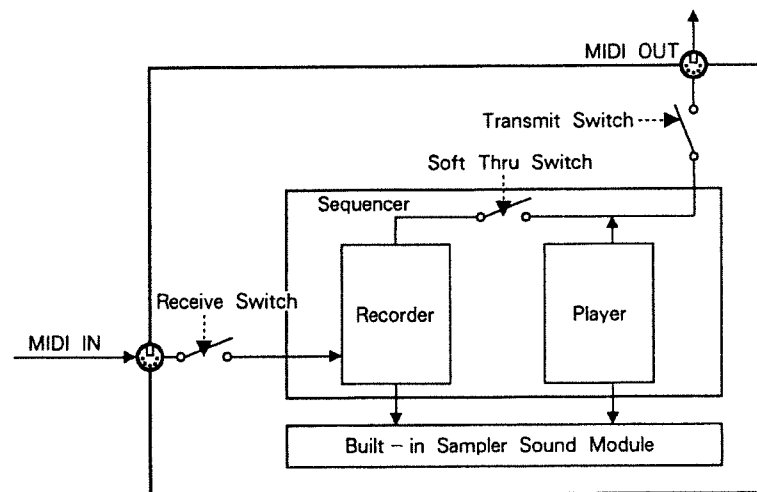

4. Creating Song Data

The S - 550 / 330 has room for six songs ; command sequences for controlling MIDI instruments.

Pattern Writing [PTRN MODE]

Each song is made up of patterns, shorter command sequences each consisting of up to 16 bars and up to 200 steps. A song may use the same pattern any number of times.

You create these patterns by real time recording MIDI events on separate channels. These events come from any other MIDI instrument.

Song Programming [SONG MODE]

A song is made up of up to 200 patterns. These 200 patterns can use altogether up to 35,000 steps in the S - 550, and 15,000 steps in the S - 330. You assign the patterns to the bar numbers of the song.

The Song Data consists of Pattern assignment to bar numbers, song names, song parameters, etc.

The S - 550 / 330 can store up to six songs without exceeding the total of 35,000 steps (for the S - 550) or 15,000 (for the S - 330).

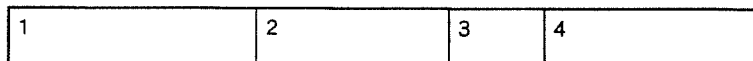

The S - 550 / 330 cannot store more than 35,000 steps (for the S - 550) or 15,000 (for the S - 330).

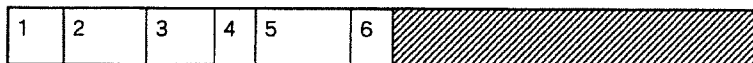

The S - 550 / 330 cannot store more than 6 songs.

5. Playing a Song [PLAY MODE]

You can play any of the six songs available either individually or in sequence. There will be a small interval between two songs.

6. Saving and Loading Data [DISK MODE]

All data in the S-550/330's memory disappears when you turn off the power.

If you wish to use new or edited song data at some later date, you must save it, that is, copy it to a permanent storage device, a floppy disk. Then when you wish to use this data, you must load it, that is, copy it from the disk back into the S-550/330 memory. The Song data you have programmed should be saved onto a song data disk formatted by the SYS-553/333. The disk can contain up to about 100,000 steps. The programmed Sound data should be saved onto a sound data disk formatted by the S-550/330 system.

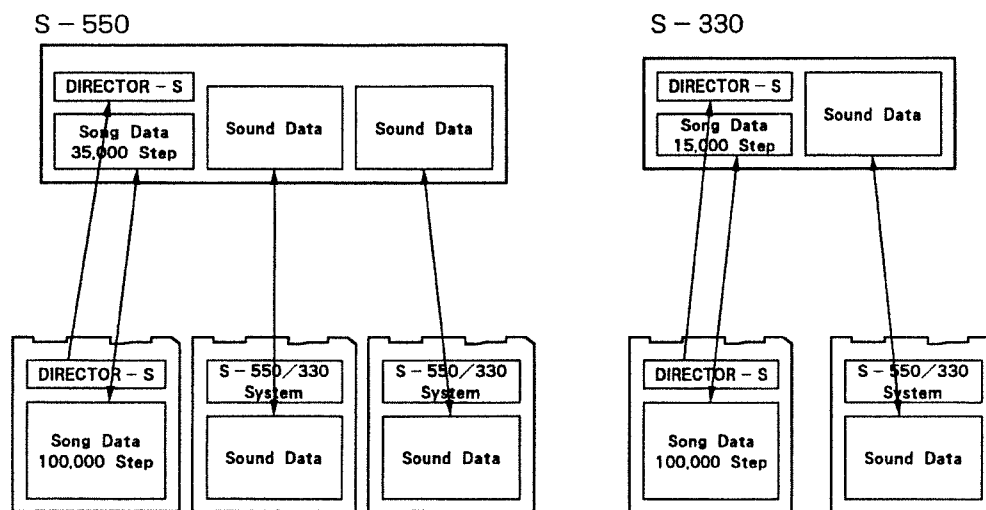

7. Standard Operation

This indicates how the button on the right of the Mouse and the INC button function.
 This indicates how the button on the left of the Mouse and the DEC button function.

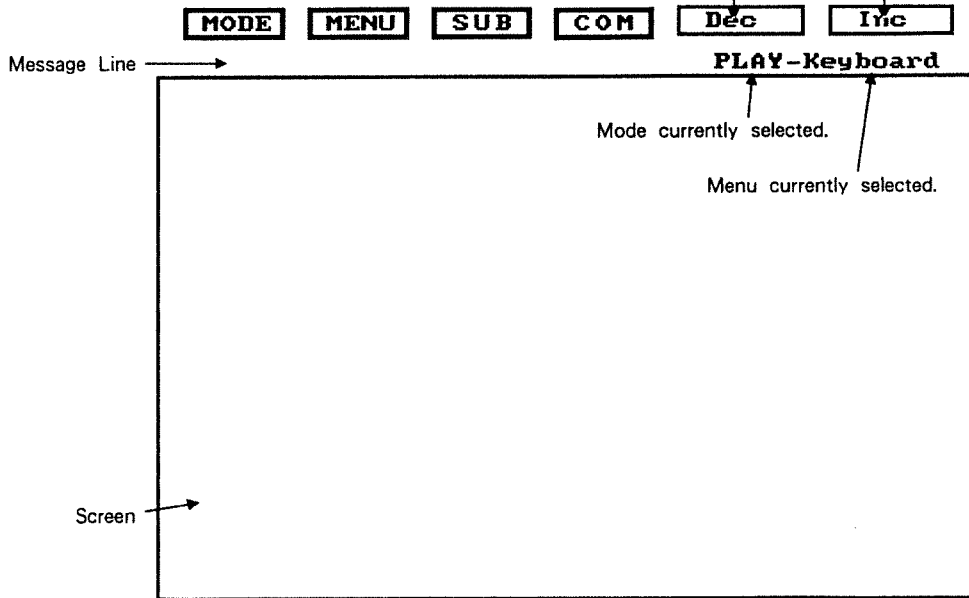

When the cursor resides in a screen, the DEC and INC buttons basically function just like the left and right buttons on the Mouse. How they currently function is shown at the upper right of the Display.

*In this owner's manual, we call the button on the left of the Mouse and the DEC button the "left button", and the button on the right of the Mouse and the INC button the "right button" for convenience.

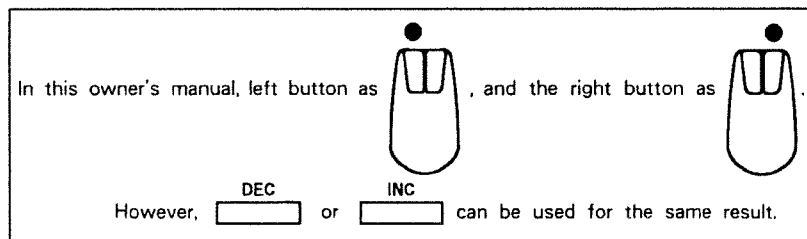
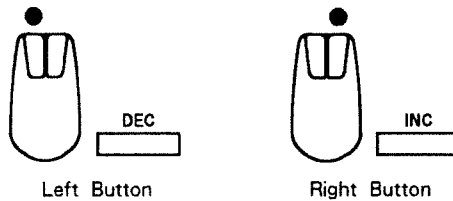

The SYS - 553/333 software allows you to choose any of the three controllers to operate the S - 550/330 ; ①the panel controls on the S - 550/330, ②the MU - 1 mouse (optional for the S - 330) or ③the RC - 100 remote controller (optional for both the S - 550/330). The RC - 100 allows you to control the S - 550/330 using an alpha dial and various buttons from distance. It is possible to use the MU - 1 and the RC - 100 at the same time, by connecting the MU - 1 mouse to the rear panel of the RC - 100.

You should select which controller is to be used ;

Writing the controller to be used onto disk memorypage 87
 Specifying the controller to be used at power - uppage 20~21
 Changing controller to be used while operating the S - 550/330
 page 111~113 in the S - 550/330 owner's manual.

When using the S - 330

"Controller = Off" (see page 21) mode is the condition in which the S - 330 can be controlled only with the panel controls. That is, the S - 330 is operated only with the built in LCD display. This mode, however, requires more time. Also, in this mode, the optional Mouse MU - 1 or remote controller RC - 100 cannot be used.

Changing Modes

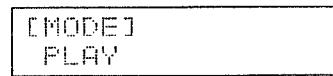

Selecting the Mode

Changing Menus

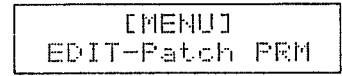

Mode Selecting the Menu

Changing Values

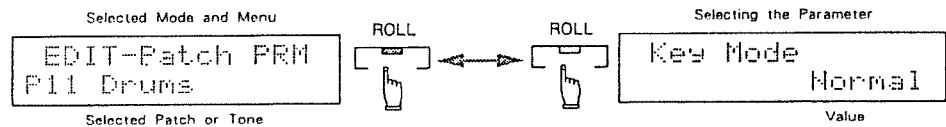



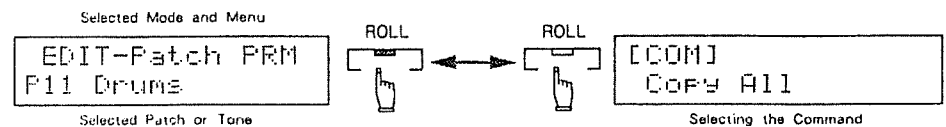









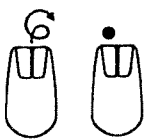

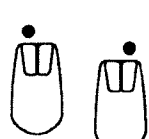

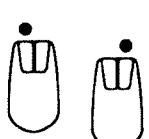

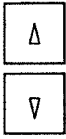





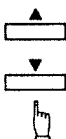

Executing Commands

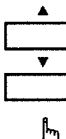

How to change modes and Menus		Each mode provides various menus. Select a menu depending on what you wish to achieve. The mode and menu currently selected are shown at the far-right on the message line.			
CRT Display					
Mouse MU-1	<p>Light up MODE in red, then open the mode window.</p>	<p>Select a mode. (Cancel)</p>	<p>Light up MENU in red, then open the menu window.</p>	<p>Select a menu. (Cancel)</p>	
Procedure	S-550	<p>Open the mode window.</p>	<p>Select a mode. (Cancel)</p>	<p>Open the menu window.</p>	<p>Select a menu. (Cancel)</p>
	S-330	<p>Open the mode window.</p>	<p>Select a mode. (Cancel)</p>	<p>Open the menu window.</p>	<p>Select a menu. (Cancel)</p>
FC-100	<p>Select a mode.</p>	<p>Open the menu window.</p>	<p>Select a menu. (Cancel)</p>		

How to change values		To change values of a parameter, move the cursor to the value to be changed and enter a new value.		
CRT Display	<p>PTRN 1 Gate Real Size 1 Metro Off</p>	<p>PTRN 1 Gate Real Size 1 Metro Off</p>	<p>PTRN 1 Gate Real Size 1 Metro On</p>	
	<p>Move the cursor to the parameter to be edited.</p>	<p>Change values.</p>		
Procedure	S-550	<p>Move the cursor to the parameter to be edited.</p>	<p>Change values.</p>	<p>Enter the values.</p>
	S-330	<p>Move the cursor to the parameter to be edited.</p>	<p>Change values.</p>	
RC-100	<p>Move the cursor to the parameter to be edited.</p>	<p>Change values.</p>	<p>Change values.</p>	<p>Enter the values.</p>

How to execute commands		Open the command window and you can execute any command provided in the menu.				
CRT Display	 	 	<p>When value entry is required.</p> 			
	Mouse MU-1	 Light up COM in red and open the command window.	 Select a command.	 Execute (Cancel)	<p>To enter a value, follow "How to change values".</p>  Move the cursor to <EXECUTE>	 Execute (Cancel)
Procedure	S-550	 Light up COM in red and open the command window.	 Select a command.	 Execute  (Cancel)	<p>To enter a value, follow "How to change values".</p>	 Execute  (Cancel)
	S-330	 Open the command window.	 Select a command.	 Execute  (Cancel)	<p>To enter a value, follow "How to change values".</p>	 Execute  (Cancel)
	RC-100	 Open the command window.	 Select a command.	 Execute  (Cancel)	<p>To enter a value, follow "How to change values".</p>	 Execute  (Cancel)

2. PREPARING TO PLAY

1. Connections

Always make sure that the power to all units are off before connecting or disconnecting an individual unit.

a. The minimum equipment required for playing

There are no speakers or amplifiers built into the S-330/550. To hear the output, connect a pair of monaural headphones or feed the signal to a speaker system through a mixer, keyboard amplifier, or other power amplifier.

in order to reproduce the excellent sound range of the S-550/330, use an amplifier or speakers that have wide frequency response and dynamic range.

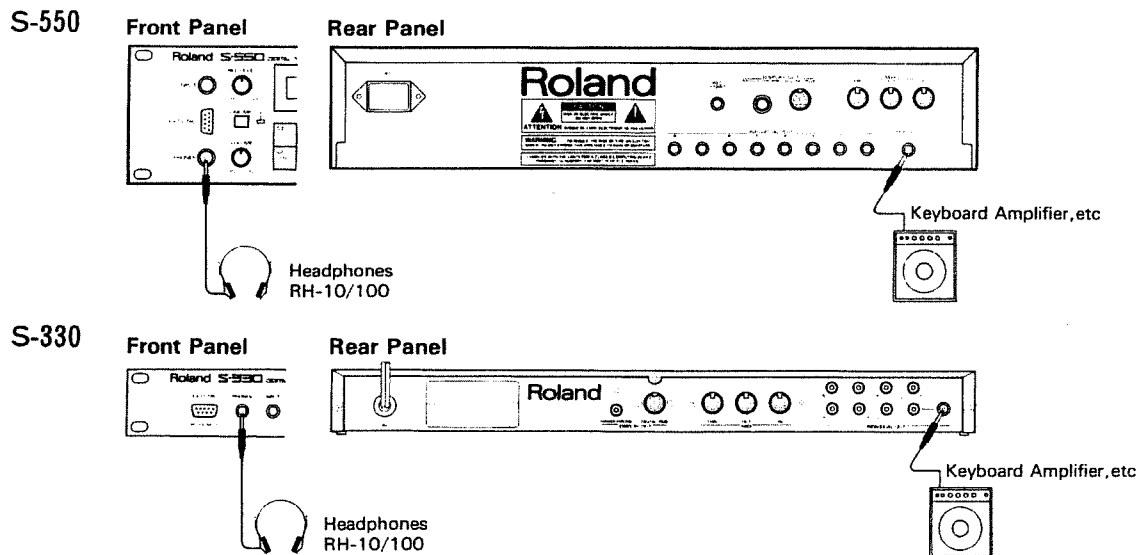

The Mixed signal output

When using the S - 550

A mixed signal is output from the MIX OUT socket. If you do not have speakers, or wish to hear the sound through headphones, connect a headphone to the PHONES socket.

When using the S - 330

The mixed signal is output from Individual Output 1, or PHONES socket. Refer to page 34 and set the Output Mode to MIX for feeding the mixed signal to an external device.

PREPARING TO PLAY

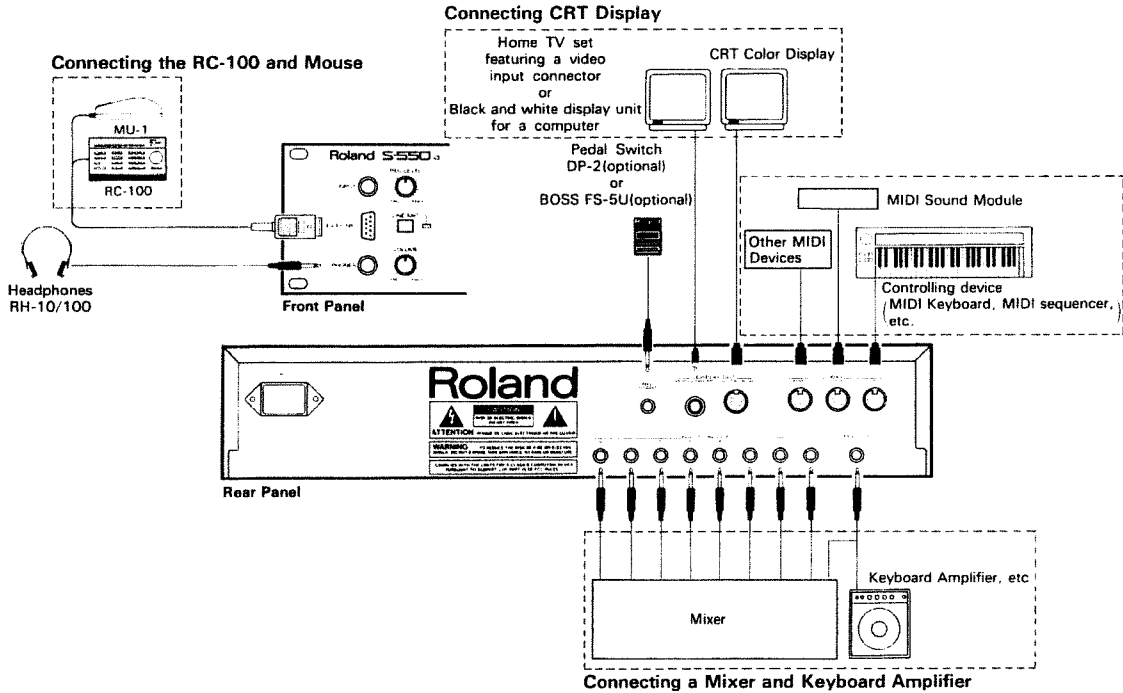

b. The minimum equipment required for programming song data

Connecting a CRT display

This software requires a CRT display. There are two types of connectors provided in the S-550/330 for connecting a CRT; one for a color monitor display and the other for a monochrome monitor. The color monitor connector can be connected to a monitor for a home computer, or a TV set featuring an RGB socket, if the input specification of the display matches the output of the S-550/330. Refer to the S-550/330's owner's manual to check if the display is compatible with the unit.

If you do not have any of those displays, you may use a home TV set with a video input socket. Connect the monochrome monitor connector on the S-550/330 to the video input using an appropriate cable. In this way, however, the display turns to black and white even in a color TV.

Connecting a MIDI Controller

Data can be entered into the sequencer from an external MIDI controller. Set the sequencer to recording mode, and play the MIDI controller. The performance information sent from the controller is recorded in the sequencer, while the same information will play the Patches on the S-550/330 on the same MIDI receive channel. MIDI devices which can be used as a controller of the S-550/330 are keyboard controllers; e.g., D-50 and S-50, and guitar controllers such as GM-70, and sequencers, etc.

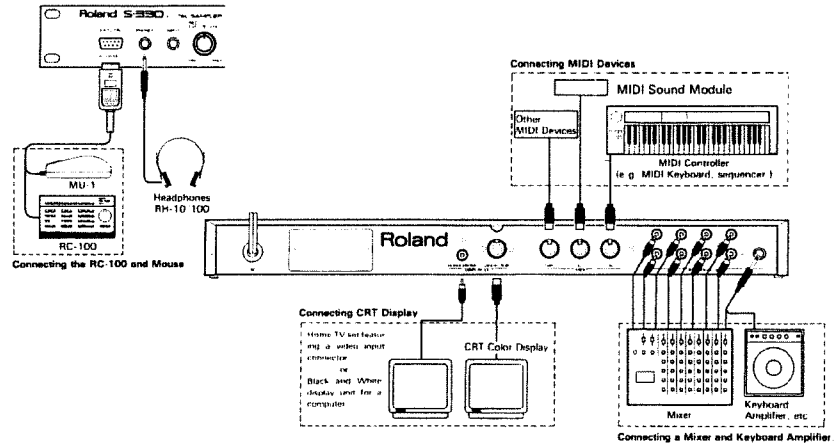

C. Other types of connections

Using the Mouse (MU-1) or RC-100

To use the MU-1 mouse (optional for the S-330) or RC-100 (optional for both S-330 and 550), connect it to the EXT CTRL connector, then set the S-550/330's internal functions to the chosen controller's. Refer to "Booting" on page 20.

Individual Output of a Patch or Tone

A Patch or Tone can be output separately from the Individual Output sockets.

When using the S-330

If you wish to send a Patch or Tone separately from the Individual Output sockets, follow the instructions on page 34 to set the Output Mode to "IND".

Playing external MIDI Sound Modules

A sequencer can play external MIDI sound modules (e.g. synthesizers, piano with MIDI sockets etc.) as well as the built-in sound sources in the S-550/330. Connect the MIDI OUT connector on the S-550/330 to the MIDI IN on the external MIDI sound module using a MIDI cable, then set the "Data Transmit" and "Software THRU" to On. (See page 56.)

Using a foot switch for starting Play or Record

When using the S-550 or RC-100

When using the S-550 or RC-100, it is possible to start to play or record with a foot switch. Connect a foot switch (e.g., DP-2) to the REC START socket at the rear of the unit.

2. Booting

Before switching the unit on, check the following.

- (1) All the connections to other equipment.
- (2) Make sure that there is no disk in the drive.

- PROCEDURE
- ① Turn on the Display.
 - ② Turn on the S - 550/330.

To use the Mouse MU - 1

Turn on the power while holding down the button shown below.

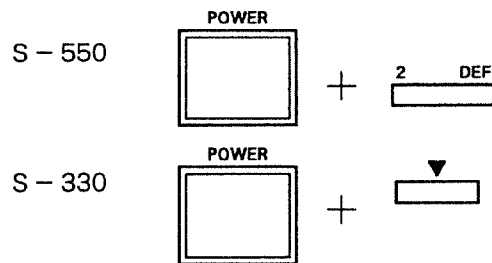

*If the cursor appears to be stuck, disconnect the mouse from the EXT CTRL connector, then reconnect it.

To use the RC - 100

Turn on the power while holding down the button shown below.

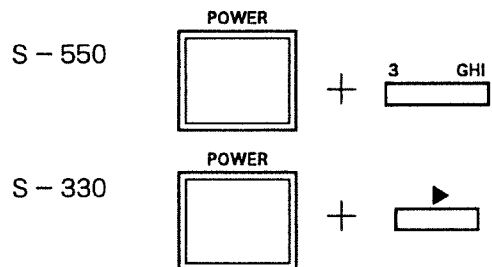

*When the unit is booted up, be sure to push the RESET button at the rear of the RC - 100.

*If the RC - 100 does not function properly, push the RESET button.

When you do not use either the MU - 1 or RC - 100

Turn on the power while holding down the button shown below, and it will be in Controller "Off" mode.

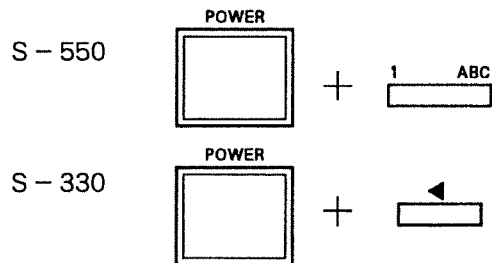

When using the S - 330

In "Controller Off" mode, the S - 330 can be operated only with the built-in LCD display. The MU - 1 or RC - 100 cannot be used with the S - 330 in this condition.

*If the unit is switched on without any other switch pressed, the unit can be operated with the controller written on the disk. How to write the controller to be used onto a disk is explained on page 87.

The message "Please Insert System Disk" appears on the screen and the LED on the drive lights.

- ③ Make sure that the WRITE PROTECT tab on the bottom of the disk, the side with the circular metal piece, is in the PROTECT position. Then insert the disk, label side up and press until it makes an audible click.

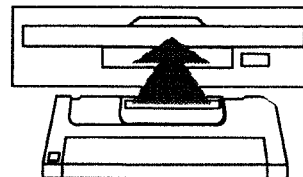

When the system program is loaded, the PLAY mode display appears.

*Do not switch off the unit or attempt to remove the disk while the disk access LED is lit (from the moment the disk is inserted until the PLAY mode display appears). Such action can irretrievably damage the data on the disk.

3. Backing Up the DIRECTOR – S System Disk

Any floppy disk will eventually wear out. Since the DIRECTOR – S software is so important to the operation of your sequencer, you should protect your investment by using only copies, called backups, and storing the original in a safe place. The same applies to all disks with important data.

*Use only double – sided, double – density, double – track 3.5 inch micro floppy disks – for example, Roland MF2 – DD micro floppy disks.

*To back up a system disk, the owner's key is necessary.

*Any sound data loaded in the internal memory will be erased by executing "Diskcopy". If you wish to retain the sound data, save it onto a disk before executing "Diskcopy".

When using the S – 330

*If you are using the S – 330, executing "Diskcopy" will erase not only the sound data but also song data. To avoid it, save the song data onto a disk, then execute "Diskcopy".

PROCEDURE ① Select the TOOL mode.

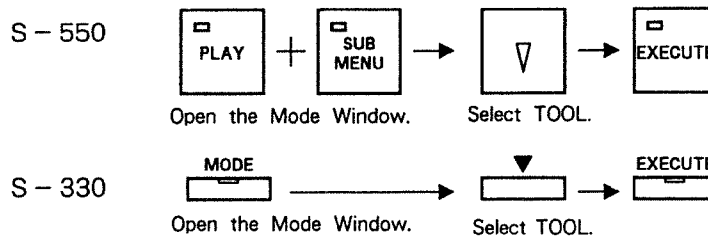

② Select "Diskcopy".

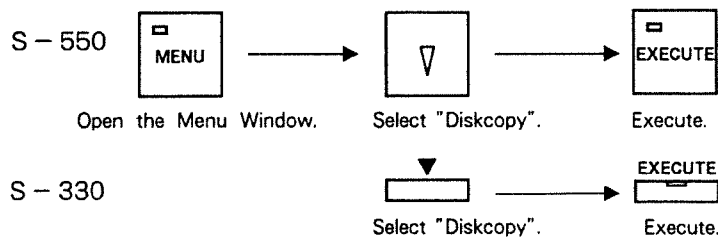

Checking the Owner's Key

③ Check the owner's key.

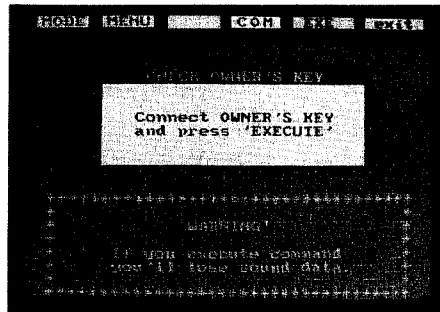

When using the control panel of the unit or the MU - 1

Connect the owner's key to the EXT CTRL socket at the front of the S - 550 / 330 then push the EXECUTE button on the S - 550 / 330.

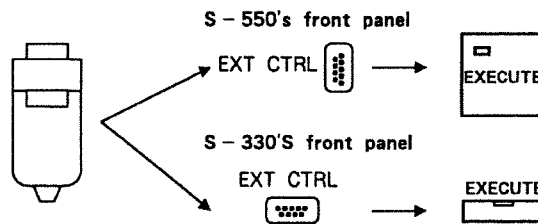

When using the RC - 100

Connect the owner's key to the EXT CTRL socket at the rear of the RC - 100, then push the EXECUTE button on the S - 550 / 330 or the RC - 100.

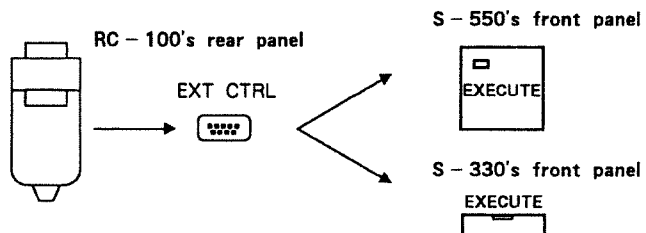

*The above procedure for checking the owner's key is required only for the first time after booting the unit. From then on, this can be skipped.

④ Insert the DIRECTOR – S system disk into the disk drive.

⑤ Press the EXECUTE button to load data into the internal memory.

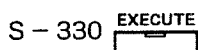
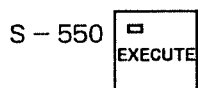

"Working", then "Now Loading" appears.

⑥ When "Insert New Disk" appears, push the Eject button to remove the disk, then set the Protect tab on a new disk (for backup) to the "WRITE" position, then insert it into the disk drive.

⑦ Push the EXECUTE button to save the data onto a disk.

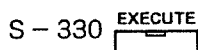
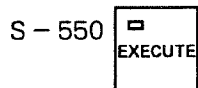

"Working", "Formatting", "Now Saving" and finally "Complete" appear on the screen.

Remove the floppy disk and return the Protect Tab to the "PROTECT" position.

Now, the backup of the DIRECTOR – S system disk is prepared.

*Your Roland dealer will, for a small fee, replace your system disk if it happens to become irreparably damaged.

4. Loading Song Data and Sound Data

After booting the S - 550/330, there exists no sound data or song data exists in its internal memory. Let's load some sound data and the song data to play it.

When using the S - 550

The S - 550 has room for two disks of sound data, and approximately 35,000 steps of song data.

When using the S - 330

The S - 330 has room for one disk of sound data, and approximately 15,000 steps of song data.

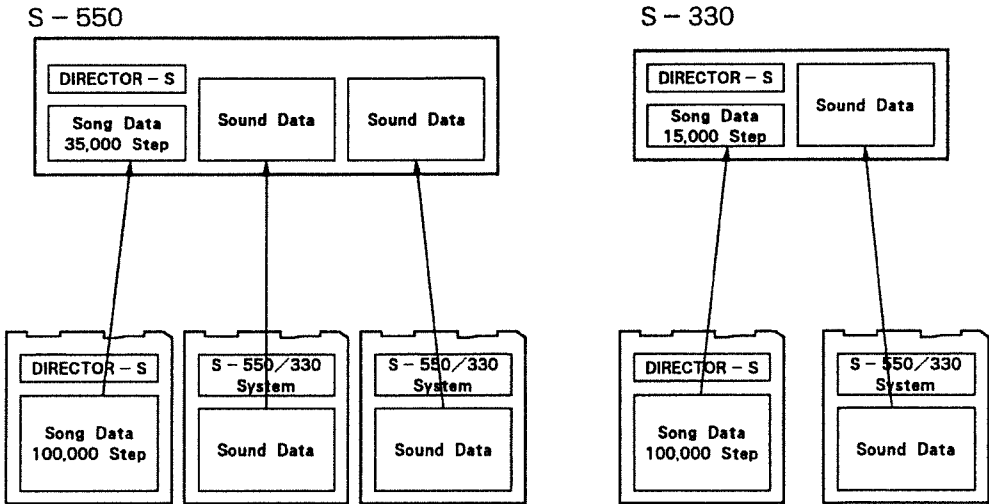

a. Loading Song Data

The internal memory can store up to six songs. Now, we load the song on the DIRECTOR-S system disk first.

- PROCEDURE** ① Make sure that the DIRECTOR-S system disk is inserted in the disk drive, then select "Load Song" in the DISK mode. (See page 14 "How to change Modes and Menus".)

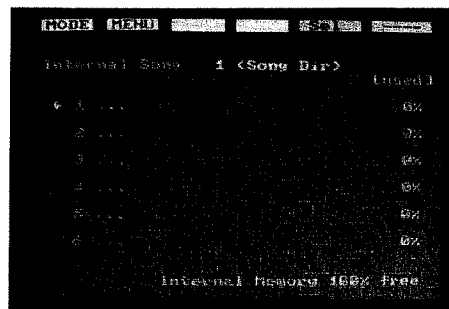

- ② Specify where to load the song. As we are loading it into the first song position, select 1.

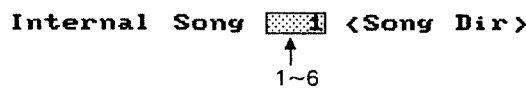

- ③ Cause the Display to show the list of the song names: Press the EXECUTE button, or Press the left button in "Song Dir".



- ④ Select the song to be loaded. The DIRECTOR-S system disk has only one song, therefore skip this and go to the next step.

- ⑤ Open the Command Window, and execute the command. (See page 16 "How to Execute Commands".)

"Now Loading" is shown for a while, then "Complete" when the loading is completed.

b. Loading Sound Data

If sound data is not loaded in the S-550/330, the sound sources cannot be played. Sound data can be loaded from the sound disk (e.g. the system disk of the S-550/330). Now, let's load sound data from the supplied sound disk. This disk contains the sound data programmed for playing the songs on the supplied song disk.

- PROCEDURE**
- ① Insert the supplied sound disk into the disk drive.
 - ② Select "Load Sound" in the DISK mode. (See page 14 "How to change Modes and Menus".)
 - ③ Select "Load Set I" (or "Load Set" for the S-330), and execute it. (See page 16 "How to Execute Commands".)

"Now Loading", then "Complete" appears when the loading is completed.

S-series Disks compatible with the SYS-553/333

With "Load" (page 85) in the DISK mode, sound data can be loaded from the following S-series disks :

S-550 disks (Ver.1.0, 1.1)

S-330 disks

S-50 disks (Ver.1.0, 2.0)

Sound Libraries (L-501 to 509, L-551 and 552)

SYS-503 type A disks

*When loading data from an S-50 disk (Ver.1.0,2.0), Sound Library (L-501 to 509) or SYS-503 type A disk, you do not need to use the Convert function, since the S-550/330 automatically performs conversion itself.

*The function data set in the PLAY mode [Receive channel, Patch, Volume, (Output mode in the S-330) : pages 34 and 35] is written within both the sound and song data. However, the one loaded last will have priority.

When loading sound data then song data

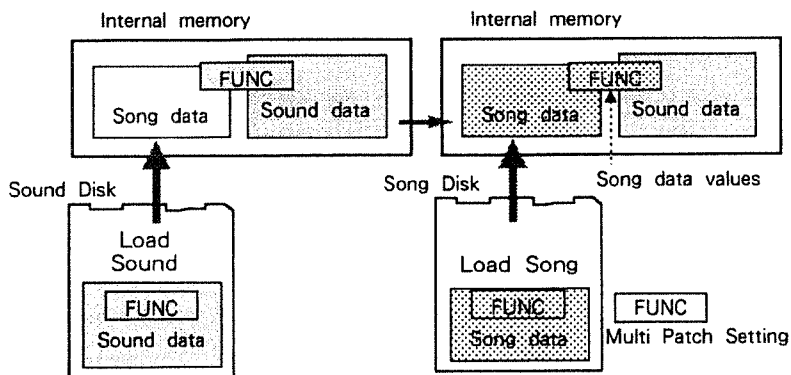

When loading the song data then sound data

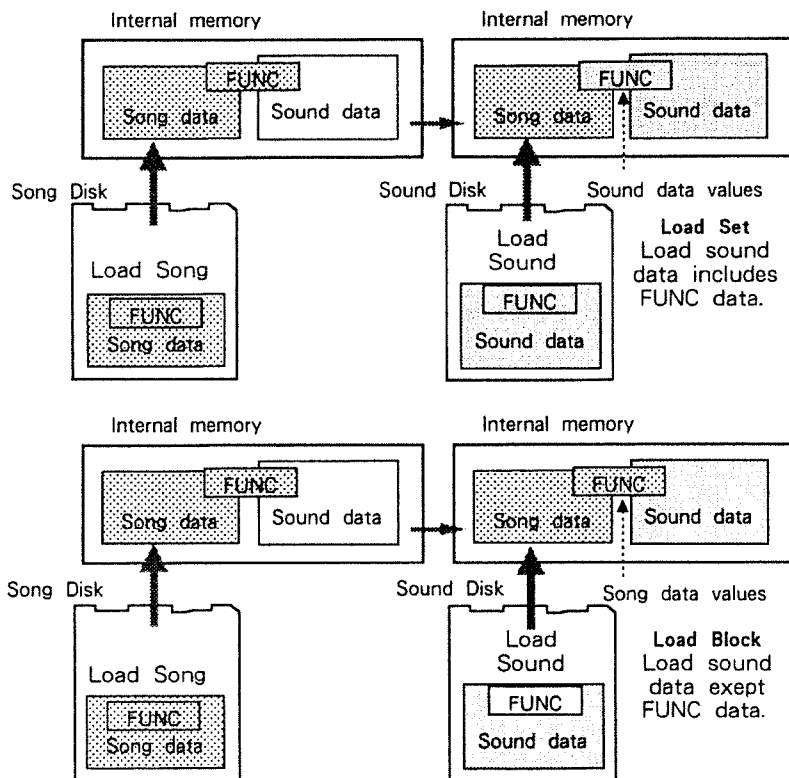

3. SONG PLAY

Sound data and Song data can be played in the PLAY mode.

PROCEDURE ① Call "Keyboard" of the PLAY mode. (See page 14 "How to change Modes and Menus".)

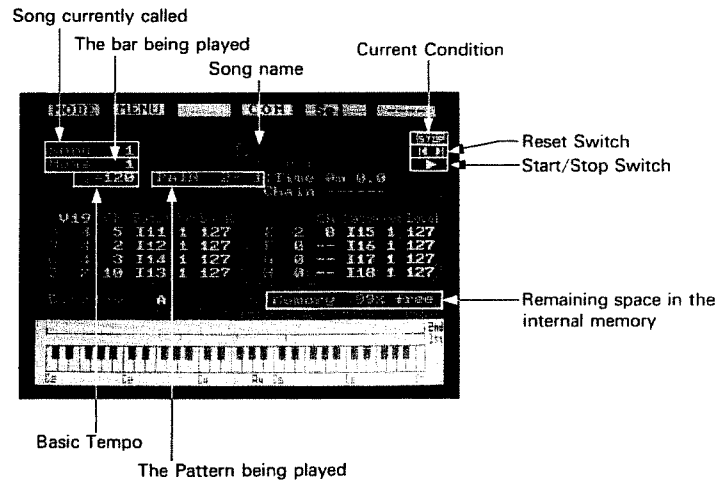

1. Playing a Song

a. Calling a Song to be played

Move the cursor to "Song", then call the song to be played. The name of the song currently selected is displayed.

As we have loaded the song data of the DIRECTOR-S system disk as the first song, select 1 here.

b. Play and Stop

Move the cursor to , then press the left button.

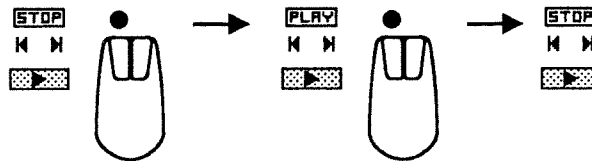

When using the RC - 100

Press the START/STOP button.

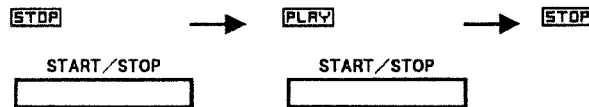

When using the S - 550 or RC - 100

Start/Stop can be controlled with the damper pedal (e.g. DP - 2, BOSS FS - 5U) connected to the DP - 2 socket at the rear of the S - 550 or START/STOP socket at the rear of the RC - 100.

When a damper pedal is connected to the S - 550, and you press the pedal for more than two seconds to stop playing, reset the Song to the beginning, therefore, data is played from the beginning by pressing the pedal once again.

c. Reset the song to the beginning

To reset the song to the beginning, move the cursor to **⏮ ⏭**, and Press the left button. To go to the end of song, Press the right button instead.

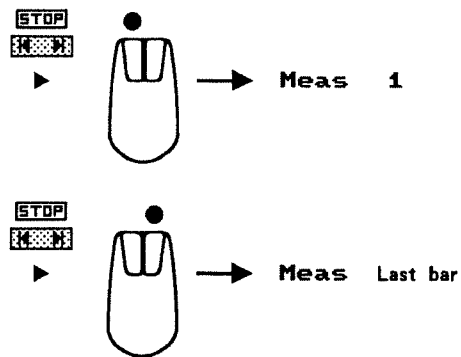

When using the RC - 100

When using the RC - 100, Pressing the INS button returns the song to the beginning and DEL button goes to the end.

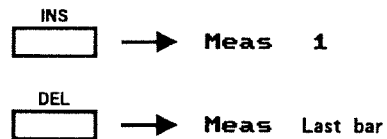

d. Starting from a particular bar

Move the cursor to "Meas", then assign the desired bar number.

e. Changing the tempo

Move the cursor to "♪", then adjust the tempo.

[V1 to V22] (Voice Fix Mode)

In this mode, 16 voices are divided into up to 8 Voice Groups, and a receive channel and a Patch to be played can be set for each Voice Group. There are 22 different ways for dividing voices. If the received note messages exceed the maximum number of voices which can sound, later note messages are ignored.

Voice Mode	1	2	3	4	5	6	7	8	9	10	11
A	16	14	12	12	10	10	10	8	8	8	8
B	0	2	4	2	6	4	2	8	6	4	4
C	0	0	0	2	0	2	2	0	2	4	2
D	0	0	0	0	0	0	2	0	0	0	2
E	0	0	0	0	0	0	0	0	0	0	0
F	0	0	0	0	0	0	0	0	0	0	0
G	0	0	0	0	0	0	0	0	0	0	0
H	0	0	0	0	0	0	0	0	0	0	0

Voice Mode	12	13	14	15	16	17	18	19	20	21	22
A	8	6	6	6	6	6	4	4	4	4	2
B	2	6	6	4	4	2	4	4	4	2	2
C	2	4	2	4	2	2	4	4	2	2	2
D	2	0	2	2	2	2	4	2	2	2	2
E	2	0	0	0	2	2	0	2	2	2	2
F	0	0	0	0	0	2	0	0	2	2	2
G	0	0	0	0	0	0	0	0	0	2	2
H	0	0	0	0	0	0	0	0	0	0	2

*If some of the receive channels of Voice Groups A to H are set to the same number, the sound may be delayed, specially when the voice mode is set to VAL (Last Note Priority : Auto Mode).

b. CH (Receive Channel)

This represents the receive channel of each Voice Group. If it is set to "Off", no MIDI message is received, therefore, no sound is generated. By setting unused Voice Groups to "--" (Off), sound delays can be minimized.

c. Patch (Patch assigned to each Voice Group)

This represents the Patch played by each Voice Group.

*Patches can be changed with MIDI Program Change messages. If you wish to change Patches with MIDI Program Change messages, set the Receive Switch [P.Chg] to ON in the "Message" of the MIDI mode. How the Program Change numbers correspond to the Patch numbers can be monitored or altered in "Prog #" of the MIDI mode.

d. Level (Volume of a Voice Group)

This sets the volume of each Voice Group.

***This parameter can be changed with MIDI Volume messages sent from an external MIDI device. Set the Receive Switch [Vol] to ON with the "Message" in the MIDI mode.**

e. Output Assignment

When using the S - 330

When you use the S-330, you can select either of the output modes ; whether to output each Patch separately or output the mixed signal. Shift the cursor to "Output", then select which you like. The Output 1 Phones socket and the PHONES socket send the same output as the Individual Output socket 1.

[IND] Individual Output

Each Patch (sound) is sent through the output socket assigned. The Output 1 Phones socket and the PHONES socket send the same output as the Individual Output socket 1. This parameter allows you to monitor or alter the output socket assignment for the Patches. If it is set so that each Tone will be output separately (see page 103 in the S-330 owner's manual), "T" will be displayed.

[MIX] Mix Output

A mixed signal is sent through the Output 1 Phones socket, PHONES socket and Individual Output socket 1. The other Individual Output sockets do not send the signal.

SONG PLAY

Patch Disp : Patch List Display

At the bottom of the CRT screen, Patch List are displayed.

Call "Patch Disp" in the PLAY mode.

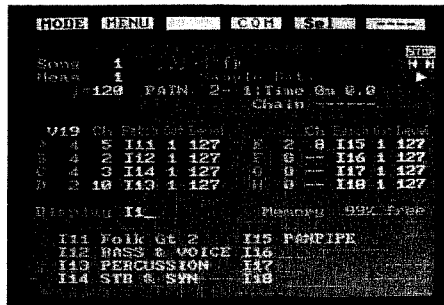

Display

The lower part of the display shows the Patch List specified at the "Display" position.

When using the S - 330

When using the S - 330, display shows not only the patch list but also the Tone list.

Mute Play : Mute playing of sa Voice Group

Any Voice Groups can be muted.

Call "Mute Play" in the PLAY mode.

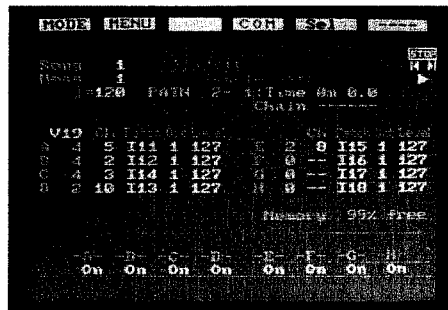

-A- -B- -C- -D- -E- -F- -G- -H-
On On On On On On On On

↑ Muted when this is set to "Off".

When this is set to "Off", the relevant Voice Group is muted.

4. PATTERN PLAY

Songs are made up of patterns. Pattern Write Mode allows you to create and edit these patterns. Although the original pattern may be on disk, always remember that you are working with a copy in the S-550/330's memory. As long as you do not erase the copy on disk, you can reload the original at any time and start over.

PROCEDURE Call the Song you wish to edit in the **PLAY Mode**.
 Since we have loaded the song data of the DIRECTOR - S system disk into the first song position, select 1 here.

Standard : Standard Display of the Pattern Mode

Note messages can be monitored in the keyboard display.

Call "Standard" of the PTRN mode.

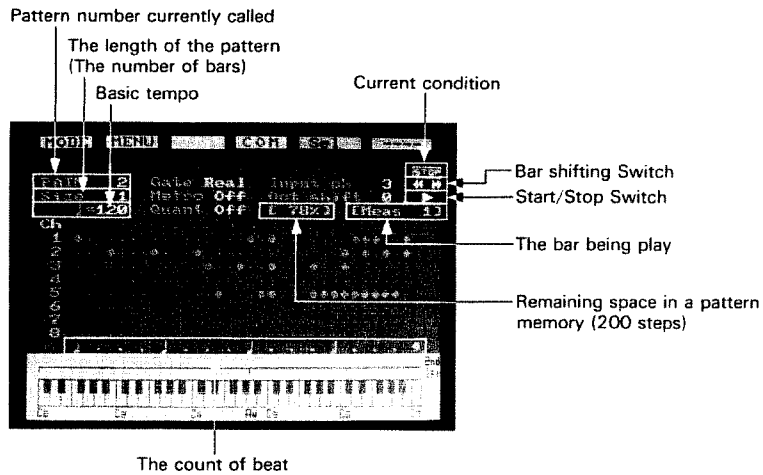

1. Playing Patterns

a. Calling the Pattern to be played

Shift the cursor to "PTRN" and enter the pattern number.

b. Playing a Pattern

Now, start the pattern. When the software reaches the end of the pattern, it automatically starts over from the beginning.

Move the cursor to , then press the left button.

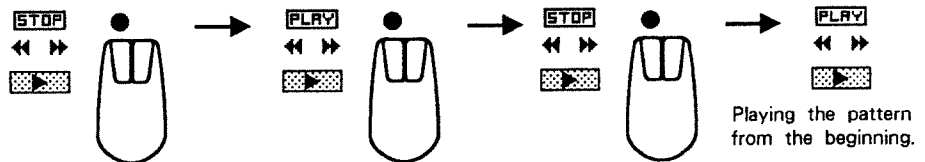

When using the RC - 100

Press the START/STOP button.

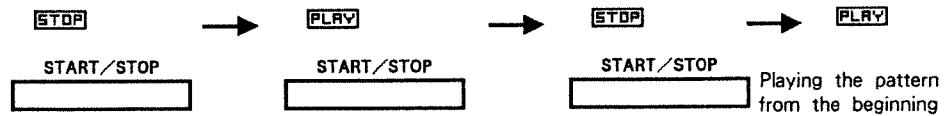

A damper pedal (e.g. DP - 2, BOSS FS - 5U) connected to the START /STOP socket at the rear of the RC - 100 works just like the START /STOP button.

c. Changing the Tempo

Move the cursor to the "J" position, then adjust the tempo.

e. Channel Play and Tone Play

By selecting a Tone from sound data of the S-550/330, you can play it, delete it or see it with the Microscope function.

Selecting a Channel or Tone

Cause the screen to show a Channel or Tone you want, and select it.

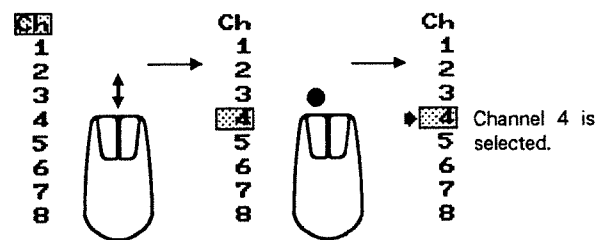

The arrow shows that the indicated Channel or Tone is selected.

Taking the same procedure again will cancel the Tone or Channel you have selected.

*When select a Tone, the software selects the 1st Tone. If the same channel uses more than one Patch, the Tone assigned to the Patch with the smallest number is selected.

Playing the Channel or Tone

After selecting a Tone, simply play it.

You may select a different Tone while the current one is still playing.

After selecting a Channel, simply play it.

You may select a different Channel while the current one is still playing.

5. MICROSCOPE

The Microscope function gives a detailed picture of the data stored in the pattern. This data includes not only the note data, but also such details as after touch, control changes and tempo data etc. This function also allows you to insert, delete, or modify this data.

Microscope screen

Call "Microscope" in the PTRN mode.

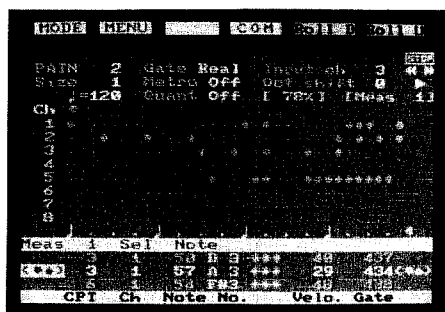

*You can perform Pattern Play in the microscope display. The method is exactly the same as the "Standard".(See page 39.)

1. Screen Layout

PROCEDURE You may scroll through the data by shifting the cursor to <↓↑>. When it comes to the end of the data, the message "End of Data" appears.

Meas The bar count relative to the start of the pattern.

CPT Clock pulse time relative to the start of the bar (0). The timing is fixed at 96 pulses per quarter note (J) for all tempos.

About CPT units

CPT stands for Clock Pulse Time. The DIRECTOR – S unit for timing steps is the clock pulse. The timing is fixed at 96 pulses per quarter note for all tempos.

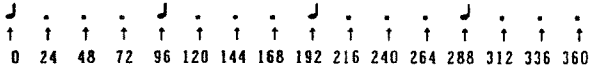
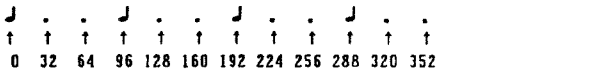
Example 1	
	0 24 48 72 96 120 144 168 192 216 240 264 288 312 336 360
Example 2	
	0 32 64 96 128 160 192 224 256 288 320 352

Length of individual notes

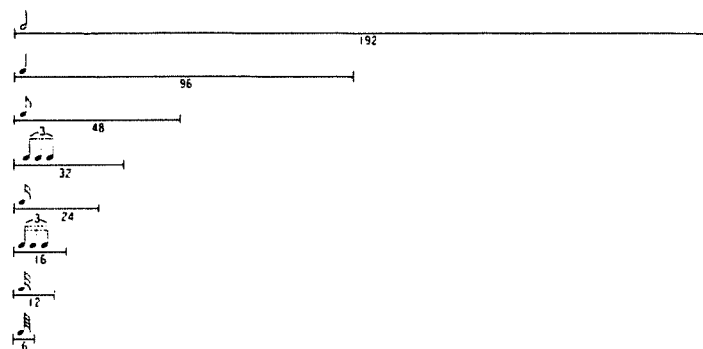

Ch MIDI channel number.

Note No. ... Note number in both octaves and key number notation. Middle C, for example is C4 and No.60.

Velo Velocity (1 – 127) of the recorded note. The relationship between this number and the loudness depends on the sound source.

Gate Note length, from the time the key is pressed until it is released. The timing unit is fixed at the same 96 pulses per quarter note as the CPT.

T , I or II Tone number.
 This is the number of the first tone for the corresponding patch. When the channel of the patch is not set to the same number as the MIDI receive channel of the S – 550 /330, the patch is not played and this column is “* *”.

*Wherever the cursor may reside, pressing the SUB MENU button will send the cursor to the <↓↑> position.(This does not apply during playing.)

2. Data Selection

a. The All Data Microscope

The Microscope function offers a choice of two types of data displays; ALL and SEL. ALL shows a more complete display of the data (all types of data). Move the cursor to the position as shown below and cause "ALL" to appear.

Meas	1	ALL	----			
	0	10	69 A 4 T17	20	12	
<◆◆>	5	10	69 A 4 T17	20	12	<◆◆>
	10	10	69 A 4 T17	20	12	
	CPT	Ch	Note No.	Velo.	Gate	

b. The SEL Data Microscope

The software also allows you to concentrate on a particular type of data. Move the cursor to the position as shown above and cause "SEL" to appear, then move the cursor to the right selecting the type of data.

- Note**.....MIDI Notes.
- PAf**.....MIDI Polyphonic after touch messages (after touch available for each note message separately).
- C.Chg**MIDI Control change messages.
- P.Chg**MIDI Program change messages.
- CAf**MIDI Channel after touch messages.
- PB**MIDI Pitch bender messages.
- Tempo**.....Tempo change data.

Meas	1	Sel	Note			
	0	10	69 A 4 T17	20	12	
<◆◆>	5	10	69 A 4 T17	20	12	<◆◆>
	10	10	69 A 4 T17	20	12	
	CPT	Ch	Note No.	Velo.	Gate	

c. Channel Microscope

Simply select a channel, and only the data of the relevant channel will be displayed.

Ch	1	2	3	4	5	6	7	8
▶	4							
Meas 1 Sel Note								
		0	4	60	C 4	T17	26	12
<▶▶>		5	4	69	A 4	T17	20	12<▶▶>
		10	4	69	A 4	T17	20	12
		CPT	Ch	Note No.		Velo. Gate		

↑

Selecting channel 4 will display only the data of channel 4.

d. Tone Microscope

Simply select a tone, and only the data of the relevant tone will be displayed.

T1	41	42	43	44	45	46	47	48
▶	42							
Meas 1 Sel Note								
		336	4	60	C 4	T42	16	12
<▶▶>		339	4	69	A 4	T42	134	12<▶▶>
		360	4	60	C 4	T42	130	12
		CPT	Ch	Note No.		Velo. Gate		

↑

Selecting T42 will display only the data of T42.

3. Modifying Data in the Microscope Screen

a. Data Modification

The Microscope display provides a functions for changing the data.

- PROCEDURE**
- ① Cause the data you wish to change to appear on the center line of the microscope display.
 - ② Move the cursor to the data item to be changed, and enter the value.

Meas	1	Sel	Note			
0	10	69	A 4	T17	20	12
<▼◆>	<input type="text" value="10"/>	<input type="text" value="69"/>	A 4	T17	<input type="text" value="20"/>	<input type="text" value="12"/> <▼◆>
10	10	69	A 4	T17	20	12
CPT	Ch	Note No.			Velo.	Gate

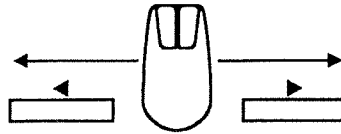

The values of note number and velocity can also be entered from the MIDI controller connected. To enter a note number, move the cursor to the note number position, and play a key on the MIDI controller. To enter a velocity value, move the cursor to the velocity value, then play a key on the MIDI controller.

c. Inserting data

The Microscope display also provides a function for inserting data.

- PROCEDURE
- ① Open the command window and select "Insert".
 - ② Enter the CPT value and data type.

Meas	1	Sel	Note	<Execute>
<◆◆>	<input type="checkbox"/>	Status	Note	<◆◆>
Enter the CPT value .		Select the data type.		
CPT	Ch	Note No.	Velo.	Gate

- ③ To insert the data, Press the EXECUTE button, or move the cursor to < Execute > and Press the left button.

Meas	1	Sel	Note	<Execute>
<◆◆>	94	Status	Note	<◆◆>
CPT	Ch	Note No.	Velo.	Gate



To cancel, Press the COMMAND button, or move the cursor to < Execute > and Press the right button.

The inserted data is shown in the middle of the screen.

This data stores the default values. Move the cursor to the position to be modified and enter a desired value.

Meas	1	Sel	Note	
0	10	69	A 4 T17	20 12
<◆◆>	<input type="text" value="94"/>	<input type="checkbox"/>	<input type="text" value="60"/> C 4 T11	<input type="text" value="64"/> <input type="text" value="1"/>
110	10	69	A 4 T17	20 12
CPT	Ch	Note No.	Velo.	Gate

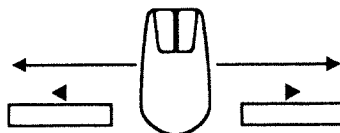

MIDI Note messages

Status	Note	<◆◆>	0	1	60	C 4	T11	64	1	<◆◆>
		CPT	Ch	Note No.				Velo.	Gate	

MIDI Polyphonic aftertouch messages

Status	PAf	<◆◆>	0	1	60	C 4	T11	0	*PAf*	<◆◆>
		CPT	Ch	Note No.				Value	*PAf*	

MIDI Control change messages

Status	C. Chg	<◆◆>	0	1	CTRL change			0	0	<◆◆>
		CPT	Ch		CTRL change			No.	Value	

Control Number

MIDI Program change messages

Status	P. Chg	<◆◆>	0	1	Program change			1	<◆◆>
		CPT	Ch		Program change			No.	

Program Change number

MIDI Channel aftertouch messages

Status	CAf	<◆◆>	0	1	Channel Af			0	<◆◆>
		CPT	Ch		Channel Af			Value	

MIDI Pitch bender messages

Status	PB	<◆◆>	0	1	Pitch bender			0	<◆◆>
		CPT	Ch		Pitch bender			Value	

Tempo change

Status	Tempo	<◆◆>	0	**	Tempo CTRL		0	%	60	<◆◆>
		CPT	Ch		Tempo CTRL		Bias	Ref		

Percentage of change

New tempo

About Tempo Data

Specify the new tempo as a percentage relative to the base tempo [J =] which appears at the upper part of the screen. The software then automatically calculates the tempo and displays it to the right of the percentage.

During playback, an arrow at the base tempo [J =] in the PTRN and PLAY mode indicates whether the tempo is faster (↑) or slower (↓) than the base tempo.

6. RECORDING PATTERN DATA

1. Recording Concept of the DIRECTOR – S

DIRECTOR – S allows you to record patterns and make up a song using those patterns. A pattern consists of up to 16 bars (or up to 200 steps). The same pattern can be used for a song as many times as you like.

In both the S – 550 and S – 330, a song can hold up to 200 patterns, within 35,000 steps (S – 550) or 15,000 steps (S – 330).

You create these patterns with real time recording of MIDI events on separate channels. These events can come from any other MIDI instrument.

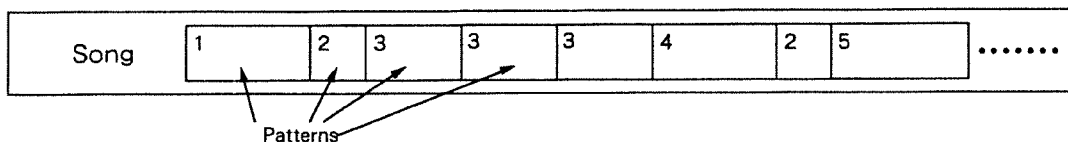

For one MIDI instrument to control another, the second must be receiving on the same channel on which the first is transmitting. Since a DIRECTOR – S song can contain data for up to 16 such channels, the sequencer is capable of simultaneously controlling 16 MIDI sound sources. The process consists of overdubbing for individual channels: you set the keyboard to transmit on the channel on which a particular instrument will be receiving, record the pattern for that instrument, and then repeat the process for the other instruments. The result is a pattern that simultaneously controls individual instruments on separate channels. For example, to record a bass guitar part, match the keyboard transmit channel to the receive channel of the bass guitar patch. Then to record the piano part, match the transmit channel of the keyboard to the receive channel of the piano patch. In this way, bass and piano parts are recorded on two different channels. At any time later, you can view the data in an individual channel, and therefore can modify a specific part or correct or delete data.

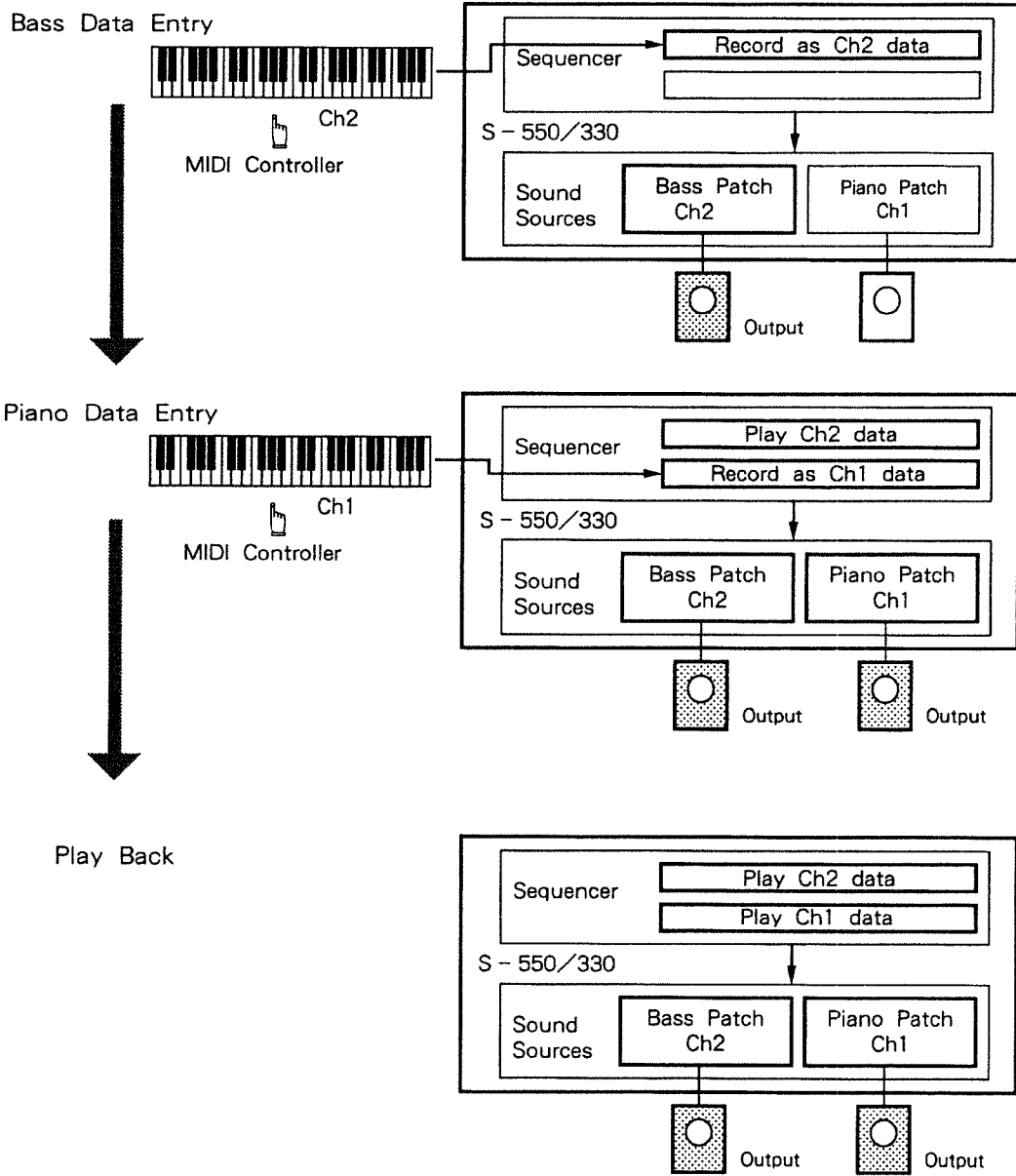

2. Preparing to Record

a. Specifying the sound source

For the best results, you should record each channel with the desired sound source played so that you can check the tone and volume with your own ears. Before proceeding, therefore, load the appropriate sound data into the S-550/330 or set up the MIDI instrument.

Sound data programming can be performed mainly in the Edit mode. However, this system does not allow you to sample wave data, truncate, mix, combine, etc. If you wish to do these things, change to the S-550/330 system using the Change System function (page 88), and use the Utility disk.

b. Clearing data

The S-550/330 has sufficient memory for six songs. Before you can record a new song, you must either select an empty song or erase the data of a current song.

Select an empty song

PROCEDURE ① Select "Keyboard", "Patch Disp" or "Mute Play" in the PLAY mode.
② Move the cursor to "Song" and select a different song.

*"Load Song" in the DISK mode gives you a listing of the songs currently available. "Used" indication shows how much of the available memory space (35,000 for the S-550 and 15,000 for the S-330) these songs occupy. The notation 0% indicates an empty song.

Erasing a Song

The following procedure erases all the data (pattern data, song name, etc.) of the current song. At this point, you may therefore wish to save the old version onto a disk. (See "Song Save" on page 84.)

PROCEDURE ① Select the "Initialize" in the SONG mode.
② Open the command window, select "All Clear", then execute.

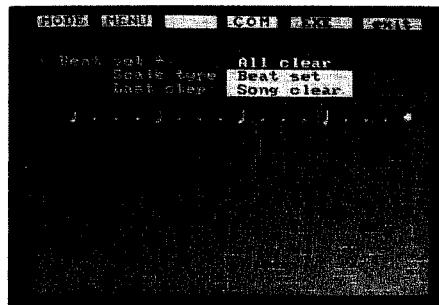

Erasing a Pattern

The following procedure is for erasing an entire pattern.

- PROCEDURE
- ① Select the "Standard" in the PTRN mode.
 - ② Open the command window and select "Delete".
 - ③ Set "Ch" and "Stat" to All.

Delete				<Execute>
[Select]	[Meas]			
Ch	All	From	1	
Stat	All	for	2	
Tone	---			

- ④ To execute erasure, Press the EXECUTE button, or move the cursor to <Execute> and press the left button.

Delete				<Execute>
[Select]	[Meas]			
Ch	All	From	1	
Stat	All	for	2	
Tone	---			



To cancel, Press the COMMAND button, or move the cursor to <Execute> and Press the right button.

Erasing the channel or tone data

The following procedure erases only the data of a tone or channel currently selected.

PROCEDURE Move the cursor to  and turn to the recording mode, then select a tone or channel.

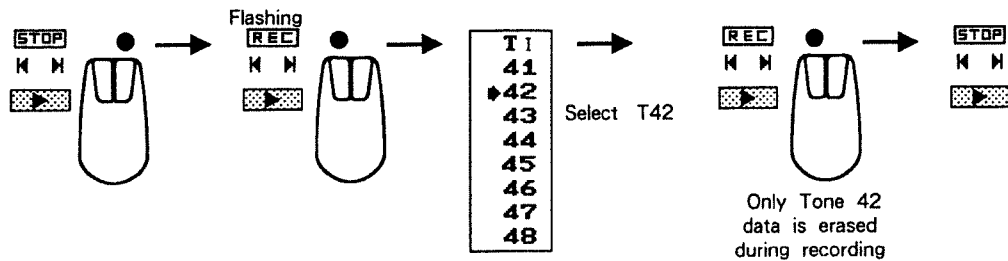
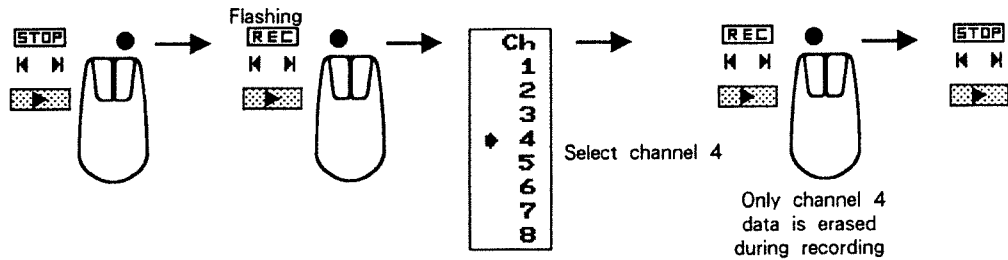

When using the RC - 100

Turn to the recording mode, then select a channel or tone.

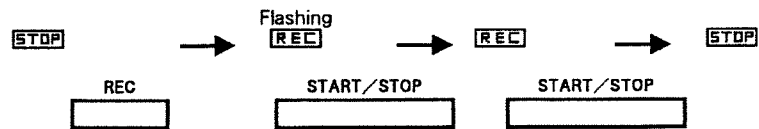

Instead of the above REC or START/STOP buttons, you may use a damper pedal (e.g. DP - 2, BOSS FS - 5U) connected to the REC or START/STOP sockets at the rear of the RC - 100.

When using the S - 550

Instead of the above REC button, you may use a damper pedal (e.g. DP - 2, BOSS FS - 5U) connected to the External Control socket DP - 2 socket at the rear of the S - 550.

c. MIDI Switches

These MIDI switches determine how MIDI messages are communicated.

*MIDI receive parameters in the sound module section of the S - 550 /330 can be performed in the "Message" of the MIDI mode.

MIDI TRANSMIT and RECEIVE Switches

PROCEDURE Select "Song PRM" in the SONG mode.

Data Receive [On/Off]

Turn the Data Receive switch "On" if you wish to control the S - 550/330 from an external MIDI controller (e.g. MIDI mother keyboard, Roland GM - 70, MC - 500). The S - 550/330 ignores messages when it is Off.

*The interface acts on the MIDI clock signals even when this switch is Off.

Data Transmit [On/Off]

Make sure that the TRANSMIT switch is "On" so that the S - 550/330 transmits to the external MIDI sound source.

*The interface transmits its MIDI clock signal even when this switch is Off.

*See "MIDI SYNC Clock" on page 94 for an explanation of the Sync clock switch.

*The software stores these switch settings as song data.

Soft Thru Switch

PROCEDURE Select the "Message" in the MIDI mode.

Software THRU [On/Off]

The DIRECTOR - S defaults the Soft THRU switch "Off", and therefore does not send the MIDI signal fed into the MIDI IN to MIDI OUT. That is, playing the MIDI controller connected to the MIDI IN has no effect on the sound module connected to the MIDI OUT. If you wish to play the sound module connected to the MIDI OUT, change the Soft THRU switch to "On".

d. Recording Switches

The memory available for patterns is limited. Frequent use of the pitch bender and after touch functions greatly increases the amount of data that DIRECTOR – S must store and fills the memory that much more quickly. Shutting off unnecessary functions saves storage space and therefore gives you the maximum possible recording time.

PROCEDURE ① Select “Song PRM” in the SONG mode.

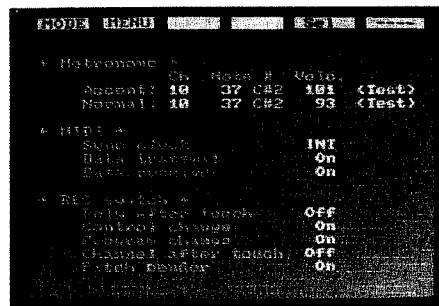

② Set the functions to On or Off.

Poly After Touch MIDI Polyphonic Aftertouch messages	[On/Off]
Control Change MIDI Control Change messages	[On/Off]
Program Change MIDI Program Change messages	[On/Off]
Channel After Touch MIDI Channel Aftertouch messages	[On/Off]
Pitch Bender MIDI Pitch Bender messages	[On/Off]

*The software stores these switch settings with the song data.

e. Metronome

A metronome is a useful adjunct to both playing patterns and recording them. The software does not limit you to a particular sound source. You are free to choose an internal source or an external MIDI source. You can then specify the channel, note number, and velocity (which ultimately determines the volume).

PROCEDURE ① Select the "Song PRM" in the SONG mode.

		Ch	Note #	Velo.	
First beat of the bar	→	Accent: 10	37 C#2	70	<Test>
Other beats	→	Normal: 10	37 C#2	70	<Test>

↑ Transmit channel
 ↑ Note number
 ↑ Velocity

② Enter the channel number, note number, and velocities.

- * The software stores metronome settings together with the song data.
- * Move the cursor to "Test" and press the left button, and you can monitor the sound. This function is not available if the MIDI channel of the unit and the transmit channel are not set to the same number.

		Ch	Note #	Velo.	
		Accent: 10	37 C#2	70	<input type="text" value="Test"/>
		Normal: 10	37 C#2	70	<input type="text" value="Test"/>



③ Select "Standard" or "Microscope" in the PTRN mode.



PTRN	1	Gate	Real	Input	Ch	--
Size	1	Metro	<input type="checkbox"/>	Oct	Shift	0
J =	83	Quant	Off	[77	×][Meas 1]

When the metronome switch is On, the S - 550 / 330 sends the appropriate notes over the MIDI channel specified in step 2.

f. Specifying the time scale

The software allows you to assign a separate time scale to each pattern. The PATTERN WRITE screen will then scales to display exactly one bar, and the bars are all the same signature.

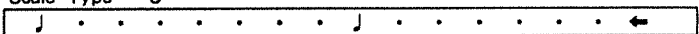
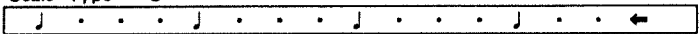
Example for Scale selection and last step setting

● 2/4	Scale Type ... 5 
	Last Step ... 32
● 4/4	Scale Type ... 3 
	Last Step ... 32
● 3/4	Scale Type ... 3 
	Last Step ... 24

Specifying the beat for an entire song

The software allows you to assign a different time scale to each pattern, and also to specify an initial time scale for all the patterns used in a song.

PROCEDURE ① Select "Initialize" in the SONG mode.

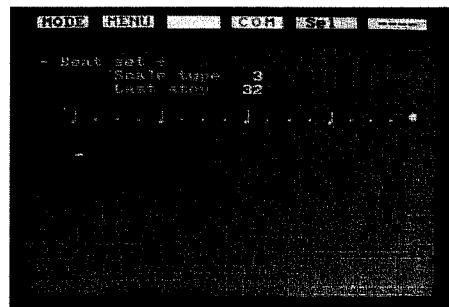

② Set values for "Scale Type" and "Last Step".

Scale Type Last step

③ Open the command window, select "Beat Set", then execute it.

*The above procedure is for initializing only cleared patterns (with no data) ; it does not affect the beat of the patterns (with some data).

Specifying the time scale for the current pattern

Set the time scale for each pattern in the PTRN mode. All bars in the pattern use this time scale.

PROCEDURE ① Select "Standard" in the PTRN mode.



② Open the command window, select "Beat Set", then execute.

③ Set values for "Scale Type" and "Last Step".

④ To execute, Press the EXECUTE button or move the cursor to < Execute > and press the left button.

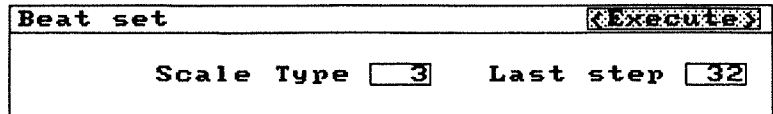

To cancel, Press the COMMAND button or move the cursor to < Execute > and press the right button.

*Reducing the bar length with either Scale Type or Last Step automatically shifts the extra data into subsequent bars, but any data shifted beyond the final bar (as determined by the SIZE parameter described later) is lost. Once it is lost, there is no way to restore it.

g. Pattern Mode Parameters

PROCEDURE Select "Standard" or "Microscope" in the PTRN mode.

PTRN	1	Gate Real	Input Ch	--
Size	1	Metro Off	Oct Shift	0
	J = 83	Quant Off	[77	%]Meas 1]

Pattern Size (Size)

A pattern may be anywhere between 1 and 16 bars long, but there is a limit of 200 steps. (One step corresponds to one line on the MICROSCOPE screen.) Be careful not to make the pattern too long and/or too complicated, you may run out of memory.

Tempo (J)

This figure gives the base tempo for the entire song. Any change therefore affects all other patterns as well.

Tempo can be changed even during recording, but the new tempo is not recorded. If you wish to write the tempo change in a pattern, insert tempo data using the microscope function. (See page 48,49.)

Recording Gate Time (Gate)









The software adjusts the gate time, the gap between the times when you press the key and when you release it, so that it is an even multiple of this value in CPT units. (See page 43 for the definition of these unit.) A value of 96, for example, makes every note a quarter note or multiple thereof. The special value "Real" specifies real-time recording, in which the sequencer records each note exactly as it is played.

Quantize (QUANT)

Real-time recording uses a time unit that corresponds to $1/96$ of a quarter note. This function allows you to smooth the recording by forcing the "Key on" events to align at intervals larger than this base unit.

***The Quantize function is for recording only. It cannot handle existing data.**

Possible quantize units are :

$1/2 \dots$		Half note	$/16 \dots$		Sixteenth - note
$1/4 \dots$		Quarter note	$/24 \dots$		Sixteenth - note triplets
$1/8 \dots$		Eighth note	$/32 \dots$		Thirty - second note
$/12 \dots$		Eighth - note triplets	$/64 \dots$		Sixty - fourth note

Input Channel (Input Ch)

No matter what channel the MIDI controller uses for transmitting, the received channel of the sequencer can be changed to this channel. For example, if the Input Channel is set to 2 and the transmit channel of the MIDI keyboard to 1, the sequencer receives data on channel 2 and therefore records and plays back the received data as channel 2 data.

Octave Shift of the received Note messages (OCT SHIFT)

This parameter can shift the messages fed into MIDI IN one or two octave up or lower. For example, if this parameter is set to "+ 1", and the C4 Note message are received, the software records and plays C5 note.

3. Recording

The DIRECTOR - S is system software that changes your S - 550/330 into a 16 - channel MIDI sequencer capable of controlling other electronic musical instruments using 16 MIDI channels. The recording process consists of overdubbing data for individual sound sources and channels. See page 10.

PROCEDURE Move the cursor to  position, Press the right button then the left button.

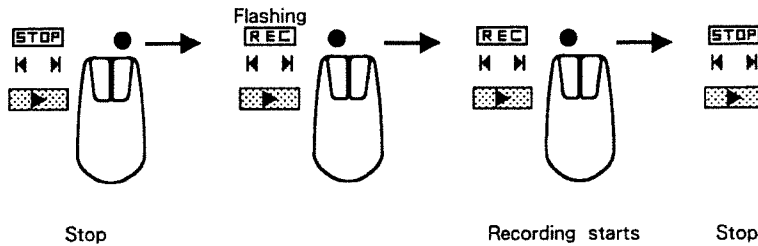

When using the RC - 100

Press the REC button, then the START/STOP button.

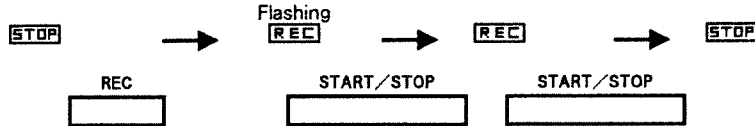

* A pattern may have up to 200 steps. If the current pattern reaches 200 steps, or the memory available for the current song drops to 0%, "Out of Memory" appears on the message line.

* You may change almost any parameter at any time during playback or recording.

* To play the sound sources in the S - 550/330, it is necessary to turn ON the Receive Switches ("Message" in the MIDI mode) of each voice group.

Punch In/Punch Out

The Punch In/Punch Out function switches the sequencer between recording (Punch In) and playback (Punch Out). This is effectively used to re-record a part of the data while playing back.

PROCEDURE

- ① Press the left button to turn to the PLAY mode.
- ② Press the right button where you wish to Punch In for re-recording. Pressing the right button once again will Punch Out, returning to the Play mode.

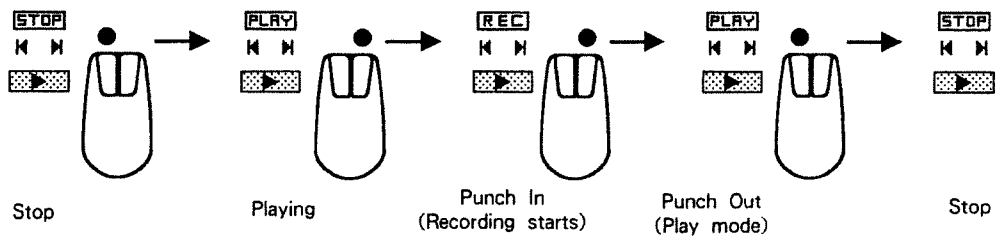

When using the RC - 100

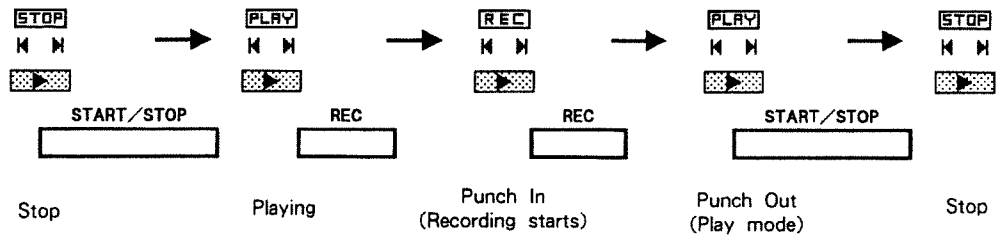

The damper pedal (e.g. DP - 2, BOSS FS - 5U) connected to the REC or START/STOP sockets at the rear of the RC - 100 works just like the REC or START/STOP button.

When using the S - 550

A damper pedal (e.g. DP - 2, BOSS FS - 5U) connected to the DP - 2 socket at the rear of the S - 550 works just like the REC button.

7. EDITING PATTERN DATA

Pattern data can be edited for each channel.

1. Copy

This function allows you to copy the data from another pattern, copy a bar or bars within the current pattern, etc. Using the copy function, it is possible to erase unneeded bars or join patterns.

PROCEDURE ① Select "Standard" in the PTRN mode.

② Open the command window and select "Copy".

Pattern Copy						<Execute>
[Source]	[Select]	[Meas]	[Mode]			
Song	1 Ch	All	From	1	Normal	
PTRN	30 Stat	All	for	1		
Times	1 Tone	---	Shift	0		

③ Set the parameters required.

- [Source]** **Song. PTRN** This determines the source pattern to be copied. Any pattern in the internal memory can be used as a source.
- Times** This sets how many times the source pattern should be copied. For example, if you copy a 1 measure pattern with Times set to 3, the same pattern will be copied three times becoming 3 measures.
- [Select]** **Ch. • Stat** ... These determine the type of data to be copied. To copy the entire data, set both to "All". To copy a particular channel or data, specify the data type (see page 44).
- Tone** When "Stat" has been set to "Note", a Tone number may be selected. The note data that uses the selected tone as the 1st tone will be copied.
- [Meas]** **From** This sets the first bar of the bars should be copied.
- for** This sets how many bars should be copied.
- Shift** When "Shift" has been set to "0", the bar assigned in "From" is copied to the first bar of the destination. When it is set to "1", the same bar is copied to the second bar.
- [mode]** When set to "Normal", the destination pattern currently selected is erased. When it has been set to "Merge", the pattern data is copied without the destination pattern being erased.

Deleting unneeded bars

Using the copy function, you can delete portions of the current pattern. The following example deletes the first bar in the size 4 pattern leaving 2 to 4 bars intact.

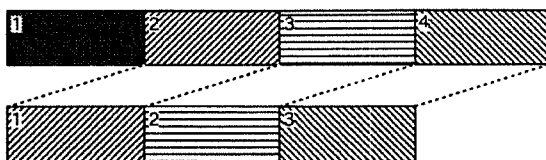

[Source] Song • PATN.....Do not change the setting. (The pattern currently selected is displayed.)

TimesSet to 1.

[Select] Ch • Stat.....Set both to All.

[Meas] FromSet to 2

forSet to 3

Shift.....Set to 0.

[mode]Set to Normal.

④To execute, Press the EXECUTE button, or move the cursor to < Execute > and press the left button.

Pattern Copy					◀Execute
[Source]	[Select]	[Meas]	[Mode]		
Song 1	Ch All	From 1	Normal		
PATN 30	Stat All	for 1			
Times 1	Tone ---	Shift 0			



To cancel, Press the COMMAND button, or move the cursor to < Execute > and press the right button.

2. Delete

This function allows you to delete any number of bars in a pattern data.

PROCEDURE ① Select the "Standard" in the PTRN mode.

② Open the command window and select "Delete".

Delete		<Execute>	
[Select]	[Meas]		
Ch	All	From	1
Stat	All	for	1
Tone	---		

③ Set the parameters required.

[Select] **Ch. • Stat** ... These determine the type of data to be deleted. To delete the entire data, set both to "All".
To delete a particular channel or data, specify the data type (see page 44).

Tone When "Stat" has been set to "Note", a Tone number may be selected. The note data that uses the selected tone as the 1st tone will be deleted.

[Meas] **From** This sets the first bar of the bars should be deleted.
for This sets how many bars should be deleted.

④ To execute, Press the EXECUTE button, or move the cursor to <Execute> and press the left button.

Delete		<Execute>	
[Select]	[Meas]		
Ch	All	From	1
Stat	All	for	1
Tone	---		



To cancel, Press the COMMAND button, or move the cursor to <Execute> and press the right button.

3. Transpose

This function allows you to transpose notes up and down in units of semi-tones. Polyphonic after touch messages will be transposed at the same time.

*Once the data is transposed, Some notes may not be returned to normal. To avoid losing the original data, copy it to a different pattern before transposing.

- PROCEDURE
- ① Select "Standard" in the PTRN mode.
 - ② Open the command window and select "Transpose".

Transpose				<Execute>	
[Select]	[Meas]			[Transpose]	
Ch	All	From	1	◆◆	Bias 0
Stat	****	for	1		
Tone	All				

- ③ Set the parameters required.

- [Select] Ch..... To transpose the entire note data (plus polyphonic after touch messages), set this to "All". To transpose a particular channel, specify the channel number.
- Tone A Tone number can be selected. The note data that uses the selected tone as the 1st tone will be transposed.
- [Meas] From This sets the first bar of the bars should be transposed.
- for This sets how many bars should be transposed.
- Bias This sets how many semi-tones should be transposed up to ±99.

- ④ To execute, Press the EXECUTE button, or move the cursor to < Execute > and press the left button.

Transpose				<Execute>	
[Select]	[Meas]			[Transpose]	
Ch	All	From	1	◆◆	Bias 0
Stat	****	for	1		
Tone	All				



To cancel, Press the COMMAND button, or move the cursor to < Execute > and press the right button.

4. Change Velocity (Chg Velo.)

This function allows you to change note velocities.

The velocity corresponds to the loudness of a note. A dynamic keyboard produces both a note number and a velocity in the range 1 – 127. A keyboard that does not have this capability gives all notes a velocity of 64. The MICROSCOPE display lists the recorded values in its "Velo." column.

Although a higher value generally produces a louder note, the relationship is usually not linear. It depends on the sound source's velocity curve.

A powerful addition to this function is the ability to rescale velocity values with slope and bias specifications.

Slope This parameter allows you to either accentuate or suppress the rate of velocity change. A value of 1.0 produces no change.

Bias This parameter raises or lowers the velocity value by the amount specified.

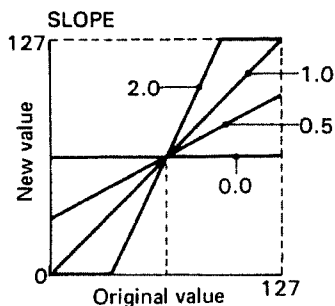

$y = ax + b$
 where y = velocity after change
 x = velocity before change
 a = Slope
 b = Bias

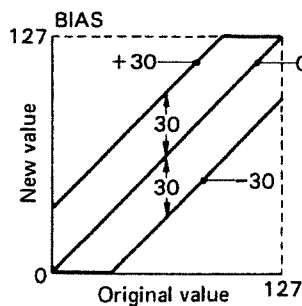

*Once the data is changed with the "Change Velocity" function, the value may not be returned to the previous one. We strongly recommend, therefore, that you always work with a copy instead of the original data.

- PROCEDURE ① Select the "Standard" in the PTRN mode.
 ② Open the command window and select "Chg Velo".

Change Velocity				<Execute>
[Select]	[Meas]			[Change]
Ch	All	From	1	Bias 0
Stat	Note	for	1	Slope 1.0
Tone	All			

- ③ Set the parameters required.

- [Select]** **Ch**.....To change the entire note data, set this to "All". To change the velocity of a particular channel, specify the channel number.
- Tone**.....A Tone number can be selected. The velocity value of note data that uses the selected tone as the 1st tone will be changed.
- [Meas]** **From**.....This sets the first bar of the bars should be changed.
- for**.....This sets how many bars should be changed.
- [Change]** **Bias**.....This sets the bias value.
- Slope**.....This sets the slope value.

- ④ To execute, Press the EXECUTE button, or move the cursor to < Execute > and press the left button.

Change Velocity				<Execute>
[Select]	[Meas]			[Change]
Ch	All	From	1	Bias 0
Stat	Note	for	1	Slope 1.0
Tone	All			



To cancel, Press the COMMAND button, or move the cursor to < Execute > and press the right button.

5. Change MIDI Channels (Chg M.Ch)

This function allows you to modify the MIDI channel numbers stored with the data.

- PROCEDURE**
- ① Select the "Standard" in the PTRN mode.
 - ② Open the command window and select "Chg M.Ch".

Change MIDI Ch					<Execute>
[Select]	[Meas]				[Change]
Ch	All	From	1	♦♦	Ch 1
Stat	All	for	1		
Tone	---				

- ③ Set the parameters required.

- [Select]** **Ch.Stat** These determine the type of data to be modified. To modify the entire data, set both to "All". To modify a particular channel or data, specify the data type (see page 44).
- Tone** When "Stat" has been set to "Note", a Tone number may be selected. The MIDI channel of data that uses the selected tone as the 1st tone will be modified.
- [Meas]** **From** This sets the first bar of the bars that should be changed.
- for** This sets how many bars should be changed.
- [Change]** **Ch** This sets MIDI channel number after changing data.
- ④ To execute, Press the EXECUTE button, or move the cursor to < Execute > and press the left button.

Change MIDI Ch					<Execute>
[Select]	[Meas]				[Change]
Ch	All	From	1	♦♦	Ch 1
Stat	All	for	1		
Tone	---				



To cancel, Press the COMMAND button, or move the cursor to < Execute > and press the right button.

8. SONG WRITE

1. Pattern Set

This function places the patterns in order, to form a song.

Song Write

Select the "Song Write" in the SONG mode.

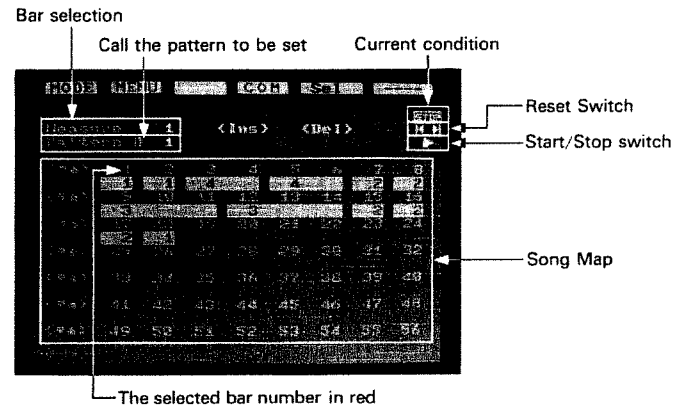

Specifying a bar by "Measure"

① Move the cursor to "Pattern", then specify the pattern number to be set.

② Move the cursor to "Measure" and assign the desired bar.
(The bar number in red.)

```

Measure  10  <Ins>  <Del>
Pattern #  1

<♦♦>   1   2   3   4   5   6   7   8
<♦♦>   9  -10- 11  12  13  14  15  16
    
```

③ Move the cursor to <Ins> and Press either the EXECUTE button or the left button. The pattern is inserted beginning at the bar lit in red.

```

Measure  10  <Ins>  <Del>
Pattern #  1

<♦♦>   1   2   3   4   5   6   7   8
<♦♦>   9  -10- 11  12  13  14  15  16
          [ 1 ]
    
```

Pattern 1 is set in bars 10 and 11.

Move the cursor to and press the EXECUTE button or the left button. The pattern inserted at the bar in red will be deleted, the following patterns shifted forward.

Specifying a bar on a map

- ① Move the cursor to "Pattern", then specify the pattern number to be set.
- ② Move the cursor to the desired bar. If the bar you want is not shown in the screen, move the cursor to <↓↑>, then press the left or the right button.

```

Measure      1    <Ins>  <Del>
Pattern #    1

<▼▲>      1    2    3    4    5    6    7    8
<▼▲>      9    10   11   12   13   14   15   16
    
```

- ③ Press the right button and the pattern is set beginning at that bar.

```

Measure      10   <Ins>  <Del>
Pattern #    1

<▼▲>      1    2    3    4    5    6    7    8
<▼▲>      9    10   11   12   13   14   15   16
    
```

● Pattern 1 is set in bars 10 and 11.



- *The next pattern cannot be set to a bar already used by the previous pattern.
- *To delete a set pattern, move the cursor to the relevant bar, then Press the left button (the bar number in red). Move the cursor to and press the EXECUTE or left button, and the pattern is deleted, the following pattern replacing it.

When using an RC - 100

Move the cursor to the bar where you wish to set the pattern, then Press the INS button. The bar becomes the first bar of the pattern. Move the cursor to the bar where you wish to delete, then Press the DEL button, and the pattern set at that bar is deleted, the following pattern replacing it.

- *An empty bar where no pattern is inserted will become a whole note rest according to the time signature of the previous pattern.

2. Play in the Set Screen

You can play the data from a desired bar and monitor the patterns you have set.

- ① Assign the beginning bar to be played.

Select a bar by "Measure"

Move the cursor to "Measure", and enter the desired bar number.
(The bar number will be in red.)

Select a bar on a map

Move the cursor to the desired bar where you wish to play back.
(the bar number will be in red.)

- ② Move the cursor to  and Press the EXECUTE button or the left button.

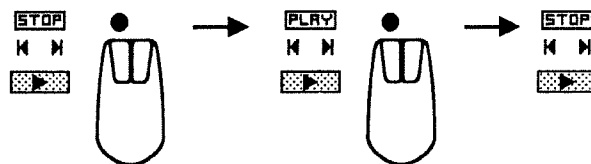

When using the RC - 100

Press the START/STOP button.



3. Song Clear

This function erases the current song data from the screen so that you can start afresh.

- PROCEDURE**
- ① Select "Initialize" in the SONG mode.
 - ② Open the command window, select "Song Clear" and execute.

*Executing this command does not initialize any pattern data, song names or song parameters.

4. Song Name

Song Name

Select the "Song Name" in the Song mode.



This function allows you to assign a 44 – character name to the song. These names make it much easier to select songs for playback or loading from disk.

- PROCEDURE**
- ① Move the cursor to the point where you wish to add characters.
 - ② Specify the character with the DEC or INC button, or right or left button on the mouse.

When using the S – 550 or RC – 100

Using the ten key pad, you can enter numbers and also letters which are shown at the upper right of the keys. The enter key makes a space. When the cursor resides at letters, capitals or small letters are alternately switched by pressing the EXECUTE button.

When using the RC – 100

A space can be inserted at the cursor position by pressing the INS button. The DEL button erases the letter at the cursor position.

9. EDITING THE ENTIRE DATA

Any part of the song data can be edited. In other words, more than one pattern written in the song can be edited at one time. However, note that if the pattern you assigned exists in another part of the song, that will also be edited whether you like it or not.

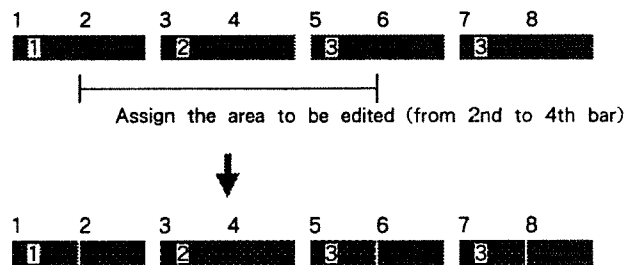

1. Delete

This function allows you to delete any number of bars in the existing data.

- PROCEDURE**
- ① Select the "Song Write" in the SONG mode.
 - ② Open the command window and select "Delete".

Block Delete				<Execute>
[Select]	[Meas]			
Ch	All	From	1	
Stat	All	for	20	
Tone	---	End =	20	

- ③ Set the parameters required.

- [Select]**
- Ch.Stat** These determine the type of data to be deleted. To delete the entire data, set both to "All". To delete a particular channel or data, specify the data type (see page 44).
- Tone** When "Stat" has been set to "Note", a Tone number may be selected. The note data that uses the selected tone as the 1st tone will be deleted.
- [Meas]**
- From** This sets the first bar of the bars should be deleted.
- for** This sets how many bars should be deleted.
The patterns within the specified bars will be deleted.

- ④ To execute, Press the EXECUTE button, or move the cursor to <Execute> and press the left button.

Block Delete				<Execute>
[Select]	[Meas]			
Ch	All	From	1	
Stat	All	for	20	
Tone	---	End =	20	



To cancel, Press the COMMAND button, or move the cursor to <Execute> and press the right button.

2. Transpose

This function allows you to transpose notes up and down in units of semi-tones. Polyphonic after touch messages will be transposed at the same time.

*Once the data is transposed, some notes may not be returned to normal. To avoid losing the original data, copy it to a different pattern before transposing.

- PROCEDURE
- ① Select the "Song Write" in the SONG mode.
 - ② Open the command window and select "Transpose".

Block Transpose				<Execute>
[Select]	[Meas]			[Transpose]
Ch	All	From	1	◆◆ Bias 0
Stat	****	for	1	
Tone	All			

- ③ Set the parameters required.

- [Select] Ch. To transpose the entire note data (plus polyphonic after touch messages), set this to "All". To transpose a particular channel, specify the channel number.
- Tone A Tone number can be selected. The note data that uses the selected tone as the 1st tone will be transposed.
- [Meas] From This sets the first bar of the bars should be transposed.
- for This sets how many bars should be transposed.
The patterns within the specified bars will be transposed.
- Bias This sets how many semi-tones should be transposed up to ± 99.

- ④ To execute, Press the EXECUTE button, or move the cursor to < Execute > and press the left button.

Block Transpose				<Execute>
[Select]	[Meas]			[Transpose]
Ch	All	From	1	◆◆ Bias 0
Stat	****	for	20	
Tone	All	End =	20	



To cancel, Press the COMMAND button, or move the cursor to < Execute > and press the right button.

3. Change Velocity (Chg Velo.)

This function allows you to change note velocities. For a detailed explanation on the Change Velocity function, see page 70.

- PROCEDURE
- ① Select the "Song Write" in the SONG mode.
 - ② Open the command window and select "Chg Velo".

Block Change Velocity				<Execute>
[Select]	[Meas]			[Change]
Ch	All	From	1	Bias 0
Stat	Note	for	1	Slope 1.0
Tone	All			

- ③ Set the parameters required.

[Select] Ch. To modify the velocity values of the entire note data, set this to "All". To change the velocity of a particular channel, specify the channel number.
 Tone A Tone number can be selected. The velocity value of note data that uses the selected tone as the 1st tone will be changed.

[Meas] From This sets the first bar of the bars should be changed.
 for This sets how many bars should be changed.
 The patterns of the specified bars will be modified.

[Change] Bias This sets the bias value.
 Slope This sets the slope value.

- ④ To execute, Press the EXECUTE button, or move the cursor to <Execute> and press the left button.

Block Change Velocity				<Execute>
[Select]	[Meas]			[Change]
Ch	All	From	1	Bias 0
Stat	Note	for	20	Slope 1.0
Tone	All	End =	20	



To cancel, Press the COMMAND button, or move the cursor to <Execute> and press the right button.

4. Change MIDI Channels (Chg M.Ch)

This function allows you to modify the MIDI channel numbers stored with the data.

- PROCEDURE
- ① Select the "Song Write" in the SONG mode.
 - ② Open the command window and select "Chg M.Ch".

Change MIDI Ch					<Execute>
[Select]	[Meas]			[Change]	
Ch	All	From	1	⇨	Ch 1
Stat	All	for	1		
Tone	---				

- ③ Set the parameters required.

- [Select] Ch.Stat These determine the type of data to be modified. To modify the entire data, set both to "All". To modify a particular channel or data, specify the data type (see page 44).
- Tone When "Stat" has been set to "Note", a Tone number may be selected. The MIDI channel of data that uses the selected tone as the 1st tone will be modified.
- [Meas] From This sets the first bar of the bars should be changed.
 for This sets how many bars should be changed.
 The patterns of the specified bars will be modified.
- [Change] Ch This sets MIDI channel number after changing data.

- ④ To execute, Press the EXECUTE button, or move the cursor to <Execute> and press the left button.

Change MIDI Ch					<Execute>
[Select]	[Meas]			[Change]	
Ch	All	From	1	⇨	Ch 1
Stat	All	for	20		
Tone	---	End =	20		



To cancel, Press the COMMAND button, or move the cursor to <Execute> and press the right button.

10. DISK COMMANDS

1. Format

You cannot save data to a new disk or one that has been used with some other equipment. You must first format it — that is, prepare it for use with the S — 550/330. Formatting a disk will erase any data saved on it.

*To save the sound data onto a brand new disk or one that has been used with some other equipment, load the S — 550/330 system using the “Change sys” functions (page 88), then format the disk for the sound data. (See page 139 in the S — 550, and page 135 in the S — 330 owner’s manual.)

*Use only double — sided, double — density, double — track 3.5 — inch floppy disks — for example, Roland MF2 — DD micro floppy disks.

* To execute this command, the owner’s key is necessary.

PROCEDURE ① Select the "Format" in the DISK mode.

*If the window indicates "Check Owner's Key", check the owner's key as explained on page 23.

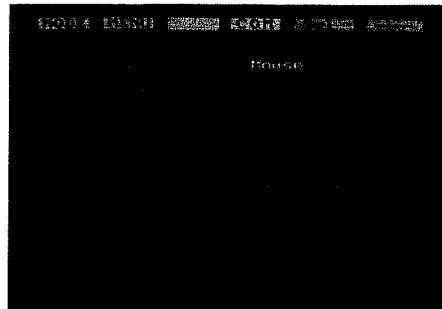

② Set the parameters required.

Save EXT CTRL [Off],[Mouse],[RC - 100]

This determines which of the controllers should be used.

*If you boot the unit using the particular procedures explained on page 20,21, the controller assigned here will be ignored.

Disk Label

A disk can have a label of up to 11 characters. Enter letters as explained on page 76.

③ Set the Protect tab on the disk to be formatted to the "WRITE" position, and insert it into the disk drive.

④ Open the command window, and execute.

The message "Complete" appears when formatting is finished.

2. Save Song

This function allows you to “save” a song data, that is, copy it from the S-550/330’s memory to a floppy disk. Song data cannot be saved on a disk used for storing the sound data of the S-550/330. Use a song disk formatted with the DIRECTOR-S.

* To execute this command, the owner’s key is necessary.

PROCEDURE ① Select “Save Song” in the DISK mode.

*If the window indicates “Check Owner’s Key”, check the owner’s key as explained on page 23.

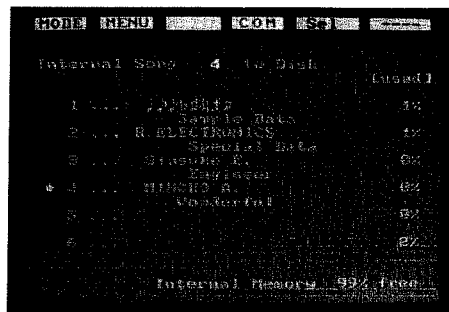

② Select a song to be copied from the song list of the internal memory.

Internal Song 1 to Disk

↑
1~6

*The indication “used” represents the percentage of the memory space (approx. 35,000 steps for the S-550, and 15,000 for the S-330) each song occupies.

③ Open the command window and execute.

The message “Saving” appears first, then “Complete” when the song is copied.

If the same song name has already been used, “Overwrite OK?” appears.

If you wish to overwrite the existing song, Press the left button or the EXECUTE button.

If you wish to cancel, Press the right button or the COMMAND button, then take the saving procedure once again using a different song name.

3. Load Song

This function allows you to "load" a song data, that is, copy it from a floppy disk to the S-550/330's memory.

- ① Insert the disk that contains the song data to be Loaded into the disk drive.
- ② Select the "Load Song" in the DISK mode.



- ③ Select the destination song number from the song listing of the internal memory.

Internal Song 1 <Song Dir>
 ↑
 1~6

- ④ Cause the screen to show the song listing currently available on the disk.

Press the EXECUTE button, or move the cursor to < Song Dir > and press the left button.

- ⑤ Select the song to be Loaded.

When the disk stores more than one song, move the cursor to < ↓ ↑ > then display the song to be Loaded using the buttons on the mouse.

*The indication "used" represents the percentage of the memory space (approx. 35,000 steps for the S-550 and 15,000 for the S-330) each song occupies.

Load... J*****
 ↑
 Display the song to be loaded

- ⑥ Open the command window and execute.

"Complete" appears when loading is finished.

4. Delete Song

This function allows you to delete any song on the song disk.

- PROCEDURE**
- ① Insert the disk that contains the song data to be deleted into the disk drive.
 - ② Select the "Del Song" in the DISK mode.
 - ③ Cause the screen to show the song listing currently available on the disk.
Move the cursor to "Song Dir" and press EXECUTE or the left button.

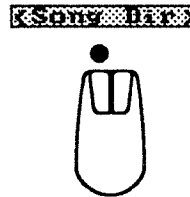

- ④ Select the song to be deleted.

When the disk stores more than one song, move the cursor to <↓↑> then display the song to be deleted at "Delete" using the left or right buttons

*The indication "used" represents the percentage of the memory space (approx. 35,000 steps for the S-550 and 15,000 for the S-330) each song occupies.

Delete J*****

↑
Display the song to be deleted.

- ⑤ Open the command window and execute.

"Working" first appears, then "Complete" when deleting is finished.

5. Save System

This function copies the DIRECTOR – S system program load in the S – 550/330's memory to any floppy formatted for use with the SYS – 553/333.

* To execute this command, the owner's key is necessary.

① Select "Save SYS" in the DISK mode.

* If the window indicates "Check Owner's Key", check the owner's key as explained on page 23.

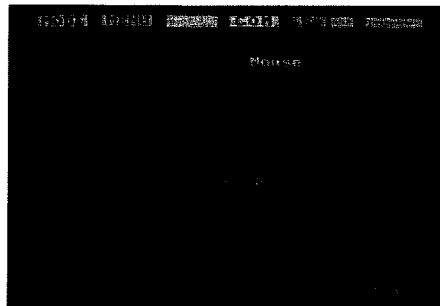

② Set the parameters required.

Save EXT CTRL [Off],[Mouse],[RC – 100]

This determines which of the controllers should be used.

* If you boot the unit using the particular procedure explained on page 20,21, the controller assigned here will be ignored.

Disk Label

A disk can have a label of up to 11 characters. Enter the letters as explained on page 76 .

③ Set the Protect tab on the disk where the system program is to be saved to the "WRITE" position, and insert it into the disk drive.

④ Open the command window, and execute.

The message "Complete" appears when the system saving is finished.

6. Change System

This function allows you to switch to the S - 550/330 sampler system without cutting the power. The main advantage is that the sound data remains in the memory and it can be edited with the Utility Disk. The sampler system provides a similar function for returning to the sequencer.

***The function of Change Systeem does not, however, save the six songs in the S - 550/330 memory. You must, therefore save them to a floppy disk if you want to keep them.**

If you use the S - 550 :

When you boot the S - 550 with the system disk you have, the CRT display shows "S - 550 System Ver.1.* *" according to the version number of your disk. The change system function is not available on Ver.1.00 to 1.09 disks.

If this applies in your case, boot the S - 550 with the utility disk supplied with the DIRECTOR - S package, then execute "Save SYS" to all the S - 550 disks you have. (See page 142 in the S - 550's owner's manual.) Do not use the original utility disk, but make a backup for this.

PROCEDURE ① Select the "Change SYS" in the DISK mode.

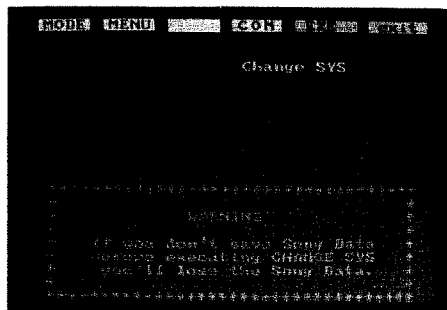

② Insert the S - 550/330 system disk into the disk drive.

③ Open the command window and execute.

"Loading" appears on the message line, showing that the sampler system program of the S - 550/330 is being loaded.

7. Disk Transfer

This function copies songs from a disk to another disk. The process consists of loading the song data on a disk into the internal memory, then save that data onto another disk as many times as required. Change disks as the screen messages tell you.

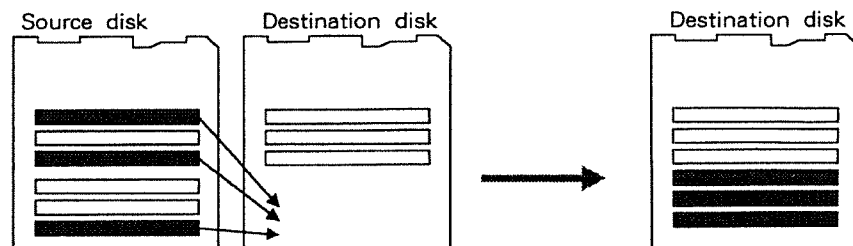

*Use only double - sided, double - density, double - track 3.5 - inch floppy disks - for example, Roland MF2 - DD micro floppy disks.

*To execute this command, the owner's key is necessary.

*Set the Protect tab on the source disk to the "PROTECT" position, and that on the destination disk to "WRITE".

*Executing "Transfer" will erase any sound data stored in the internal memory. If you wish to retain the data, save the sound data onto a disk beforehand.

When using the S - 330

*If you use the S - 330, using the "Transfer" function will erase not only the sound data but also the song data. Save the song data onto a disk, if necessary.

PROCEDURE ① Select the "Transfer" in the TOOL mode.

*If the window indicates "Check Owner's Key", check the owner's key as explained on page 23.

② Make sure that the Protect tab on the source disk is set to the "PROTECT" position, then insert the disk into the disk drive.

③ Cause the screen to show the song listing currently available on the disk.

<Song Dir>



Press the EXECUTE button, or move the cursor to < Song Dir > and press the left button.

④ Select the song to be copied.

In the beginning, all the songs are ready to be copied ("J" mark is indicated at the head of each song name). Erase the songs you do not want to copy.

⑤ Move the cursor to the <↓↑> position, then cause the screen to display the songs not to be copied at "Select" using the button on the mouse.

Select. J*****

↑
Display the song not to be copied.

Press the EXECUTE button, or move the cursor to "Select" and press the left button. This will make the song names black, and the "J" marks at the head of the songs to "rests". Now, those songs are not copied.

Select. !■■■■■■■■■■ Now, the song will not be copied.

↓ Turns black
Turns to a rest mark

- ⑥ Open the command window and execute.

"Working", then "Now Loading" and finally "Insert Dest. Disk" appears.

- ⑦ When the message "Insert Dest.Disk" is shown, press the Eject button to remove the disk, switch the Protect tab on the destination disk to the WRITE position, then insert it into the disk drive.

- ⑧ Press the EXECUTE button or the left button.

"Working", then "Now Saving" and finally "Working" appears.

If the same song name has been used on the destination disk, the message "Overwrite OK?" appears.

If you do not mind erasing the song on the destination disk, Press the EXECUTE or the left button.

If you wish to retain the song on the destination disk, Press the COMMAND or the right button. Pressing the COMMAND button cancels the Transfer command. Pressing the right button saves the next song instead of the current one.

To load this second version, load song data from the source disk with "Load Song", change the song name in the "Song Name" of the SONG mode, then execute "Save Song" onto the destination disk.

When the saving is done, "Complete" appears.

*Your Roland dealer will, for a small fee, replace your system disk should it become irreparably damaged.

11. OTHER FUNCTIONS

1. Chain Play

This function allows you to sequentially play the songs currently in the internal memory.

The Chain Play function plays the songs in numerical order and assumes that they have been loaded in the correct order.

- PROCEDURE**
- ① Call the **PLAY** mode. (Any menu in the **PLAY** mode except "Tone Map")
 - ② Open the command window and execute.

Chain Play Set							<Execute>
Song #	1	2	3	4	5	6	Loop
Switch	Off	Off	Off	Off	Off	Off	Off
Start	Manual						

↓ "On" for playing a song.
 "Auto" for playing a song, then automatically going to the next one.
 "Manual" for playing a song and wait for the next one every time.
 ↓ "On" for returning from the 6th song to the 1st.

- ③ Set the parameter required.

Switch ···· Set this "On" to use the Chain Play function.

Loop ····· Set this "On" to resume playing (1st song after 6th).
 Set this "Off" to stop playing after the last song.

Start ····· Set this to "Auto" for continuous chaining – to play the current song then play the next one in sequence, automatically.

Set this to "Manual" for stepwise chaining – to play the current song, switch to the next song and wait for you to play it.

- ④ To execute, Press the **EXECUTE** button, or move the cursor to <Execute> and Press the left button.

To cancel, Press the **COMMAND** button, or move the cursor to <Execute>, and Press the right button.

- ⑤ Play the song data as explained on page 30.

2. Time Calc

This function works out the time needed for the current song to be played.

Select "Time Calc" in the TOOL mode.

The screen shows the tempo and the valid range for the "Time Calc". Here, the current base tempo and the 1st to last measure of the song.

```

Basic Tempo    120
Measure from   1
for           106 End = 106

```

If you wish to calculate the time in the tempo and the valid range as displayed currently, leave them.

If you wish to change the tempo, change the value of the Basic Tempo.

*When the basic tempo is changed, the tempo of the current song will change.

If you wish to work out the time just for a part of the song data, specify the beginning and the number of bars.

① Open the command window and execute.

```

Basic Tempo    120
Measure from   1
for           106 End = 106
Total Time    3m 30.0s

```

Executing the command will work out the time according to the base tempo, beat and tempo of each bar.

*When the calculated result exceeds 99 minutes and 59.9 seconds, the message "Data Over Flow" appears on the message line, without the time displayed.

2. MIDI SYNC Clock

This function allows you to synchronize the sequencer with other MIDI equipment, making the sequencer either the master or the slave.

*** Sync clock signals are transmitted or received regardless of the MIDI channel setting.**

INT – The S – 550/330 as master

To use the song data of the DIRECTOR – S as master, be sure to set the MIDI Transmit Switch (page 56) to “Off”. Otherwise, the slave instrument will be played with the DIRECTOR – S’s song data.

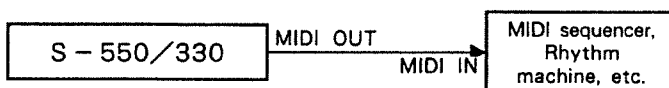

The following procedure is for setting the sequencer so that it uses its own built-in clock.

PROCEDURE ① Select the “Song PRM” in the SONG mode and set “Sync Clock” to INT.

*** Now, the DIRECTOR – S always transmits MIDI sync clock.**

② Set the slave unit so that it can receive the sync clock.

Play a song or pattern on the SYS – 553/333, and the slave unit will sync with it.

EXT - The S - 550/330 as slave

To synchronize the DIRECTOR-S's song data with the external equipment, set the MIDI Receive Switch (page 56) to "Off". Otherwise, the S - 550/330 will be played by the performance data of the master instrument.

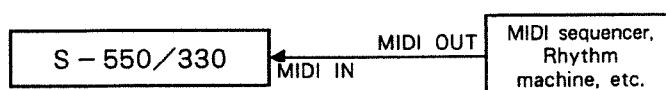

The following procedure is for setting the sequencer so that it will follow the clock of another MIDI instrument.

- PROCEDURE**
- ① Select "Song PRM" in the SONG mode, and set "Sync Clock" to EXT.
 - ② Set the master unit so that it can transmit sync clock.

Set the DIRECTOR - S to "**ETOP**" condition, and play the master instrument, and the DIRECTOR - S will sync with it.

12. APPENDIX

Recording MC – 500 data

The DIRECTOR – S sequencer software stores a song as a list of patterns, and so cannot directly record MIDI data from the MC – 500. There is, however, a simple way around this restriction. The key to the procedure is to find repeating phrases in the MC – 500 data and to record these as DIRECTOR – S patterns. (This approach also saves memory space.)

*The S – 550/330 time signature must match that of the MC – 500 data.

*If the original changes tempo, use the MICROSCOPE display to insert a tempo change line at the appropriate spot.

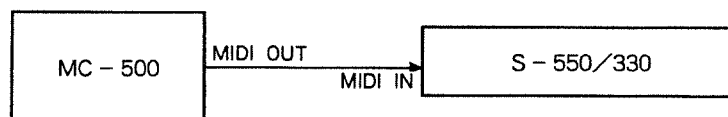

Setting Up the MC – 500

- PROCEDURE
- ① Make sure that the MC – 500 is on STANDBY, press the MIDI, 1, 0, and ENTER keys in order.
 - ② Rotate the alpha dial to turn the TRANSMIT CLK switch ON.
 - ③ Press the STOP key to return to STANDBY, then press  to select the first bar.

Setting Up the DIRECTOR – S

- PROCEDURE
- ① Select a vacant song or make one with the “All Clear” function (page 53).
 - ② Using the “Song PRM” in the SONG mode, set the “Sync Clock” switch to EXT and the “Data Receive” to “On”.
 - ③ If you wish to record the entire MC – 500 data, turn all the recording switches ON. If not, cut unneeded data by setting them to OFF.
 - ④ Select the “Standard” in the PTRN mode and call Pattern 1.

Set GATE to “Real” and “Quantize” to “Off”.

Set the “Size” parameter. Although longer parameters are easier to work with, remember that the limit is 200 steps per pattern and that space requirements depend on data density.

- ⑤ Use the same procedure to set the “Size” parameter to one or two bars longer than you need.

* Making the size too small can produce such problems as (1) when the Note messages are long and stretch to the next pattern, the keyoff data should be recorded at the beginning of the next pattern. (2) When the timing of stopping the MC – 500 performance is delayed, overdubbing from the beginning of the pattern currently set is done.

Recording

PROCEDURE ① Set the S - 550/330 to the recording condition in the PTRN mode.

The mark **REC** flashes on the message line.

② Press the **PLAY** key on the MC - 500 to start both units.

On the S - 550/330, the mark **REC** now stays alight.

③ Press the **STOP** key on the MC - 500 in the bar following the last one desired in the pattern, that is, 2 bars before the end of the pattern.

The MC - 500 plays the rest of the bar and then stops. The S - 550/330 stops at the same time, and the mark on the message line changes to **STOP**.

④ Reduce the pattern size on the S - 550/330 to eliminate the extra bar.

Moving to the Next Pattern

PROCEDURE ① On the S - 550/330, select the pattern number and set the size to one or two bars longer than necessary.

② On the MC - 500, press the **→** **←** keys to make the word MEAS flash, and use the alpha dial or ten - key pad (with ENTER) to move the starting bar.

③ Use the procedure in the preceding section to record this pattern.

When you have finished recording all the patterns, join them together and give the new song a name.

Sequencer section

Function ...		Transmitted	Recognized	Remarks
Basic Channel	Default Changed	all ch x	all ch 1 - 16	not BASIC ch
Mode	Default Messages Altered	x x *****	x x	
Note Number	True voice	0 - 127 *****	0 - 127 0 - 127	
Velocity	Note ON Note OFF	○ x 9n, v = 0	x x	v = 1 - 127
After Touch	Key's Ch's	○ ○	* 1 * 1	
Pitch Bender		○	* 1	
Control Change	0 - 63 64 - 121	○ ○	* 1 * 1	
Prog Change	True #	○ *****	* 1 0 - 127	
System Exclusive		x	x	
System Common	Song pos Song sel Tune	○ (CLOCK = INT) ○ (CLOCK = INT) x	○ (CLOCK = EXT) ○ (CLOCK = EXT) x	
System Real Time	Clock Command	○ (CLOCK = INT) ○ (CLOCK = INT)	○ (CLOCK = EXT) ○ (CLOCK = EXT)	
Aux Messages	Local ON/OFF All Notes OFF Active Sens Reset	x x x x	x x x x	
Notes	* 1 Can be set to ○ or x manually			

Mode 1 : OMNI ON, POLY
 Mode 2 : OMNI ON, MONO

Mode 3 : OMNI OFF, POLY
 Mode 4 : OMNI OFF, MONO

○ : Yes
 x : No

Internal voice section

Function ...		Transmitted	Recognized	Remarks
Basic Channel	Default Changed	x x	1 - 16 * 4 1 - 16 * 4	* 2
Mode	Default Messages Altered	x x *****	MODE 3 x	
Note Number	True voice	x *****	12 - 120 12 - 120	
Velocity	Note ON Note OFF	x x	○ x	v = 1 - 127
After Touch	Key's Ch's	x x	x * 1	
Pitch Bender		x	* 1	
Control Change	1 7 64 100, 101 6, 38	x x x	* 1 * 1 * 1 * 1	Modulation Volume Hold RPC LSB,MSB Data Entry LSB,MSB Number 0 Pitch bend Sensitivity
Prog Change	True #	x *****	* 1 0 - 127 0 - 127	* 3
System Exclusive		x	x	
System Common	Song pos Song sel Tune	x x x	x x x	
System Real Time	Clock Command	x x	x x	
Aux Messages	Local ON/OFF All Notes OFF Active Sens Reset	x x x x	x ○ (123 - 127) x x	
Notes	* 1 Can be set to o or x manually, and memorized by disk. * 2 Memorized by disk. * 3 Program change number for each Patch can be set freely. * 4 Up to 8 differnt channels can be set on SYS - 553.			

Mode 1 : OMNI ON, POLY
Mode 2 : OMNI ON, MONO

Mode 3 : OMNI OFF, POLY
Mode 4 : OMNI OFF, MONO

○ : Yes
x : No

1. TRANSMITTED DATA

- 1.1 All memorized messages are transmitted on Playing
- 1.2 All received messages are transmitted if SOFT THRU is ON.
- 1.3 Created message

■ Mode message

All note off

<u>Status</u>	<u>Second</u>	<u>Third</u>
BnH	7BH	00H

* When all notes turn to off.

■ System common

Song position pointer

<u>Status</u>	<u>Second</u>	<u>Third</u>
F2H	llH	mmH

lll : 0H - 7FH (0 - 127)
 mml : 0H - 7FH (0 - 127)

* When SYNC CLOCK is set at INT.

Song select

<u>Status</u>	<u>Second</u>
F3H	ssH

ssH : 0H - 5H (song 1 - 6)

* When SYNC CLOCK is set at INT.

■ Real time message

Timing clock

<u>Status</u>
F8H

* When SYNC CLOCK is set at INT.

Start

<u>Status</u>
FAH

* When SYNC CLOCK is set at INT.

Continue start

<u>Status</u>
FBH

* When SYNC CLOCK is set at INT.

Stop

<u>Status</u>
FCH

* When SYNC CLOCK is set at INT.

2. RECOGNIZED DATA

2.1 Memorized messages while in RECORD mode

■ Note event

Note off

<u>Status</u>	<u>Second</u>	<u>Third</u>
8nH	kkH	vvH
9nH	kkH	00H

kkH : Note number 00H - 7FH (0 - 127)
 vvH : ignored

Note on

<u>Status</u>	<u>Second</u>	<u>Third</u>
9nH	kkH	vvH

kkH : Note number 00H - 7FH (0 - 127)
 vvH : ignored

■ Poly after touch

<u>Status</u>	<u>Second</u>	<u>Third</u>
AnH	kkH	vvH

kkH : Note number 00H - 7FH (0 - 127)
 vvH : Value 00H - 7FH (0 - 127)

* Only sequencer section.

■ Control change

Continuous controller

<u>Status</u>	<u>Second</u>	<u>Third</u>
BnH	mmH	vvH

mmH = 0H - 7FH (0 - 127)
 vvH = 0H - 7FH (0 - 127)

■ Program change

<u>Status</u>	<u>Second</u>
CnH	ppH

ppH : Program number 0H - 7FH (0 - 127)

■ Channel after touch

<u>Status</u>	<u>Second</u>
DnH	vvH

vvH : Value 0H - 7FH (0 - 127)

■ Pitch bender

<u>Status</u>	<u>Second</u>	<u>Third</u>
EnH	llH	mmH

lll : 0H - 7FH (0 - 127)
 mmH : 0H - 7FH (0 - 127)

2.2 Recognized message for sync.

■ System common

Song position pointer

<u>Status</u>	<u>Second</u>	<u>Third</u>
F2H	llH	mmH

llH : 0H - 7FH (0 - 127)
mmH : 0H - 7FH (0 - 127)

* When SYNC CLOCK is set at EXT.

Song select

<u>Status</u>	<u>Second</u>
F3H	ssH

ssH : 0H - 5H (song 1 - 6)

* When SYNC CLOCK is set at EXT.

■ Real time message

Timing clock

<u>Status</u>
F8H

* When SYNC CLOCK is set at EXT.

Start

<u>Status</u>
FAH

* When SYNC CLOCK is set at EXT.

Continue start

<u>Status</u>
FBH

* When SYNC CLOCK is set at EXT.

Stop

<u>Status</u>
FCH

* When SYNC CLOCK is set at EXT.

INDEX

About tempo data	49	Individual output of a Patch or Tone	19
Back up the DIRECTOR - S system disk	22	Input Ch	63
Booting	20	Input Channel	63
CRT Display	4	Introduction	7
Calling a song to be played	30	Keyboard	35
Calling the pattern to be played	39	Labels for the INC and DEC buttons	4
Caring for your floppy disks	5	Load song	85
Chain play	92	Loading song data and sound data	25
Change system	88	Loading song data	26
Changing the tempo	31	Loading sound data	27
Changing the tempo	39	MIDI Implementation Chart	100
Changing the screen	40	MIDI TRANSMIT and RECEIVE switches	56
Channel play and Tone play	41	MIDI switches	56
Checking the Owner's key	23	MIDI sync clock	94
Clearing data	53	Metronome	58
Connecting a CRT Display	18	Microscope	42
Connections	17	Microscope screen	42
Conneting a MIDI Controller	18	Channel microscope	45
Creating Song Dta	10	Data selection	44
Delete song	86	Deleting data	47
Disk Transfer	89	Inserting data	48
Disk commands	82	Modifying data in the microscope screen	46
Editing Pattern data	66	The SEL Data microscope	44
Change MIDI channels	72	The All data microscope	44
Change Velocity	70	Tone microscope	45
Chg M.Ch	72	Mute Play	36
Copy	66	OCT SHIFT	63
Delete	68	Octave shift of the received note messages	63
Deleting unneeded bars	67	Other Functions	92
Transpose	69	Other types of connections	19
Editing the entire data	77	Output assignment	34
Change MIDI channels	81	Output of mixed signal	17
Change Velocity	80	Owner's key	4
Chg M.Ch	81	Patch Disp	36
Chg Velo.	80	Pattern Play	38
Delete	78	Pattern Writing	10
Transpose	79	Pattern mode parameters	62
Erasing a pattern	54	Pattern set	73
Erasing a song	53	Pattern size	62
Erasing the channel or tone data	55	Playing a Song	11
Features	3	Play and stop	30
Format	82	Play in the set screen	75
Function data set in the play mode	32	Play mode screens	35
Gate	62	Playing a pattern	39
How to change modes and Menus	14	Playing external MIDI sound modules	19
How to change values	15	Playing patterns	39
How to execute commands	16	Playing the channel or tone	41
How to use this Owner's Manual	7	Preparing to play	17
If you use the System Ver.1.0 with the S - 550	5	Preparing to record	52

Punch in - Punch out	65
Quant	63
Quantize	63
Recording	64
Recording MC - 500 data	96
Recording concept of the DIRECTOR - S	50
Recording gate time	62
Recording pattern data	50
Recording switches	57
Reset the song to the beginning	31
S - series disks compatible with the SYS - 553/333	27
Save song	84
Saving and loading data	11
Select an empty song	53
Selecting a channel or tone	41
Sequencer and Sound Sources	9
Size	62
Soft Thru switch	56
Song Name	76
Song Programming	10
Song Write	73
Song clear	75
Song play	29
Song write	73
Specifying the sound source	52
Specifying the time scale	59
Specifying the beat an entire song	60
Specifying the time scale for the current pattern	61
Standard	38
Standard Operation	12
Systyem save	87
Tempo	62
The minimum equipment required for playing ..	17
The minimum equipment required for programming song data	18
Three supplied disks	8
Time calc	93
Tone Map	37
Using foot switch for starting play or record ..	19
Using the Mouse (MU - 1) or RC - 100	19
Voice mode	32
J	62

SPECIFICATIONS

DIRECTOR – S

SYS – 553 : MIDI Sequencer System Software for the S – 550

SYS – 333 : MIDI Sequencer System Software for the S – 330

Memory Capacity

[Internal]	S – 550	S – 330
Songs	6 Songs	6 Songs
Steps	Approx. 35,000 Steps	Approx. 15,000 Steps (Throughout the 6 songs)

[Disk]

Double – sided, double – density, double – track 3.5 inch micro floppy disk

Songs	100 Songs	100 Songs
Steps	Approx. 100,000 Steps	Approx. 100,000 Steps

Song Data

- Pattern Data

Steps in a Pattern	200 Steps	200 Steps
Steps in a Song	Approx. 35,000 Steps	Approx. 15,000 Steps

- Pattern Set

Bars in a Song	400 Bars	400 Bars
Patterns in a Song	200 Patterns	200 Patterns

- Song Name 44 Characters
- Base Tempo Variable from 10 to 250
- MIDI Switches
- Recording Switches
- Metronome

Recording Ability

Resolution	96 per quarter note
Quantize	1/2 to 1/64 (per bar)
Gate Time Constant Input	1 to 9999 (= 96 per quarter note)
External Clock	Corresponding to MIDI Sync Clock and Song Position Pointer

Pattern Editing

- Microscope
 - Edit
 - Delete
 - Insert
- Pattern Edit (The valid area can be set)
 - Copy
 - Delete
 - Transpose
 - Change Velocity
 - Change MIDI Channels
- Song Edit (The valid area can be set)
 - Delete
 - Transpose
 - Change Velocity
 - Change MIDI Channels

MEMO

 Roland®

27013562

UPC

27013562



10981

SYS-553/333

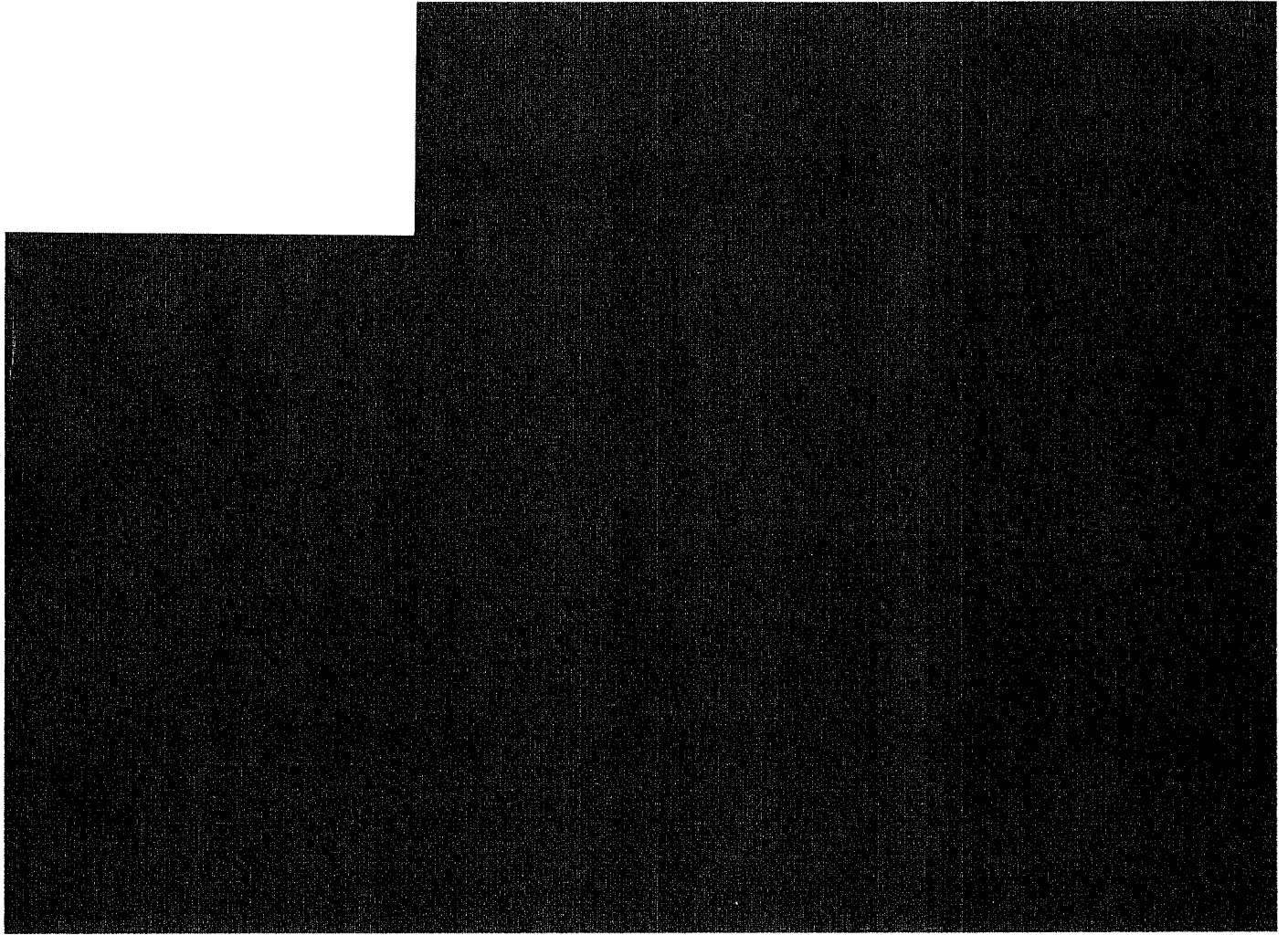

 Roland