

Roland<sup>®</sup>

# SPD-6 PERCUSSION PAD

## Owner's Manual

Thank you and congratulations on your choice of the Roland SPD-6.

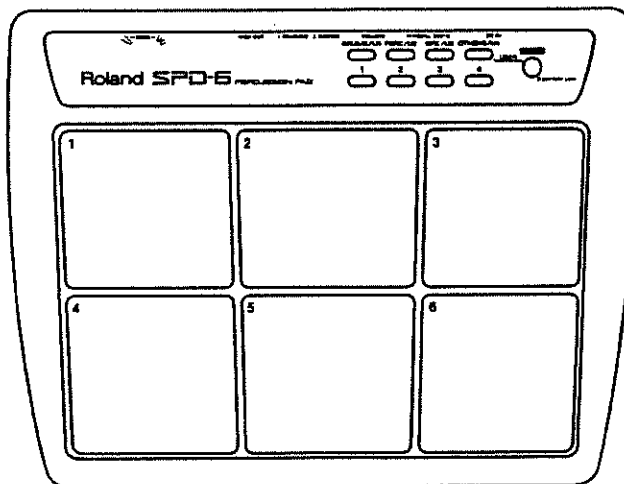
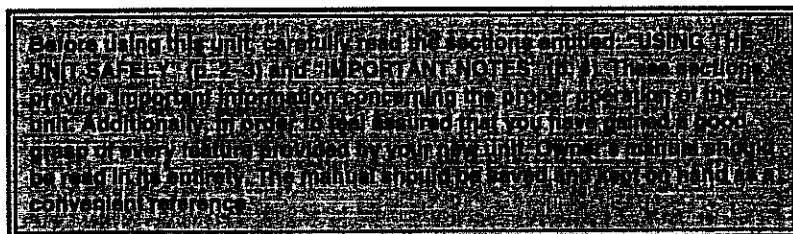

### Terms Used in This Manual

- Names of buttons are enclosed in square brackets; e.g., [DRUMS/U1].
- Patch (sound set) names are listed as DRUMS-1 or U2-2, etc.
- Paragraphs preceded by **NOTE** are notes of caution. Be sure to read them.
- (p. \*\*) indicates a reference page.
- In a table, procedures are summarized as follows.  
[DRUMS/U1]→[1]:
  1. Press the [DRUMS/U1] button.
  2. Press the [1] button.

\* GS (GS) is a registered trademark of Roland Corporation.

Copyright © 2000 ROLAND CORPORATION

All rights reserved. No part of this publication may be reproduced in any form without the written permission of ROLAND CORPORATION.

# USING THE UNIT SAFELY

## INSTRUCTIONS FOR THE PREVENTION OF FIRE, ELECTRIC SHOCK, OR INJURY TO PERSONS

### About ⚠ WARNING and ⚠ CAUTION Notices

|                  |  |
|------------------|--|
| <b>⚠ WARNING</b> | Used for instructions intended to alert the user to the risk of death or severe injury should the unit be used improperly.   |
| <b>⚠ CAUTION</b> | Used for instructions intended to alert the user to the risk of injury or material damage should the unit be used improperly.<br>* Material damage refers to damage or other adverse effects caused with respect to the home and all its furnishings, as well to domestic animals or pets. |

### About the Symbols

|          |  |
|----------|--|
| <b>⚠</b> | The ⚠ symbol alerts the user to important instructions or warnings. The specific meaning of the symbol is determined by the design contained within the triangle. In the case of the symbol at left, it is used for general cautions, warnings, or alerts to danger.         |
| <b>⊘</b> | The ⊘ symbol alerts the user to items that must never be carried out (are forbidden). The specific thing that must not be done is indicated by the design contained within the circle. In the case of the symbol at left, it means that the unit must never be disassembled. |
| <b>⦿</b> | The ⦿ symbol alerts the user to things that must be carried out. The specific thing that must be done is indicated by the design contained within the circle. In the case of the symbol at left, it means that the power-cord plug must be unplugged from the outlet.        |

### ALWAYS OBSERVE THE FOLLOWING

#### ⚠ WARNING

- Before using this unit, make sure to read the instructions below, and the Owner's Manual. 



---

- Do not open (or modify in any way) the unit or its AC adaptor. 

---

- Do not attempt to repair the unit, or replace parts within it (except when this manual provides specific instructions directing you to do so). Refer all servicing to your retailer, the nearest Roland Service Center, or an authorized Roland distributor, as listed on the "Information" page. 

---

- Never use or store the unit in places that are:
  - Subject to temperature extremes (e.g., direct sunlight in an enclosed vehicle, near a heating duct, on top of heat-generating equipment); or are 
  - Damp (e.g., baths, washrooms, on wet floors); or are 
  - Humid; or are
  - Exposed to rain; or are
  - Dusty; or are
  - Subject to high levels of vibration.



---

- This unit should be used only with a rack or stand that is recommended by Roland. 

#### ⚠ WARNING

- When using the unit with a rack or stand recommended by Roland, the rack or stand must be carefully placed so it is level and sure to remain stable. If not using a rack or stand, you still need to make sure that any location you choose for placing the unit provides a level surface that will properly support the unit, and keep it from wobbling. 

---

- Use only the specified AC adaptor (BOSS PSA series), and make sure the line voltage at the installation matches the input voltage specified on the AC adaptor's body. Other AC adaptors may use a different polarity, or be designed for a different voltage, so their use could result in damage, malfunction, or electric shock.   



---

- Do not excessively twist or bend the power cord, nor place heavy objects on it. Doing so can damage the cord, producing severed elements and short circuits. Damaged cords are fire and shock hazards! 







---

- This unit, either alone or in combination with an amplifier and headphones or speakers, may be capable of producing sound levels that could cause permanent hearing loss. Do not operate for a long period of time at a high volume level, or at a level that is uncomfortable. If you experience any hearing loss or ringing in the ears, you should immediately stop using the unit, and consult an audiologist. 





---

- Do not allow any objects (e.g., flammable material, coins, pins); or liquids of any kind (water, soft drinks, etc.) to penetrate the unit.   













### **WARNING**

- Immediately turn the power off, remove the AC adaptor from the outlet, and request servicing by your retailer, the nearest Roland Service Center, or an authorized Roland distributor, as listed on the "Information" page when:
  - The AC adaptor or the power-supply cord has been damaged; or
  - Objects have fallen into, or liquid has been spilled onto the unit; or
  - The unit has been exposed to rain (or otherwise has become wet); or
  - The unit does not appear to operate normally or exhibits a marked change in performance.
- In households with small children, an adult should provide supervision until the child is capable of following all the rules essential for the safe operation of the unit.
- Protect the unit from strong impact. (Do not drop it!)
- Do not force the unit's power-supply cord to share an outlet with an unreasonable number of other devices. Be especially careful when using extension cords—the total power used by all devices you have connected to the extension cord's outlet must never exceed the power rating (watts/amperes) for the extension cord. Excessive loads can cause the insulation on the cord to heat up and eventually melt through.
- Before using the unit in a foreign country, consult with your retailer, the nearest Roland Service Center, or an authorized Roland distributor, as listed on the "Information" page.
- Batteries must never be recharged, heated, taken apart, or thrown into fire or water.

### **CAUTION**

- The unit and the AC adaptor should be located so their location or position does not interfere with their proper ventilation.
- Always grasp only the plug or the body of the AC adaptor when plugging into, or unplugging from, an outlet or this unit.
- Whenever the unit is to remain unused for an extended period of time, disconnect the AC adaptor.
- Try to prevent cords and cables from becoming entangled. Also, all cords and cables should be placed so they are out of the reach of children.

### **CAUTION**

- Never climb on top of, nor place heavy objects on the unit.
- Never handle the AC adaptor body, or its plugs, with wet hands when plugging into, or unplugging from, an outlet or this unit.
- Before moving the unit, disconnect the AC adaptor and all cords coming from external devices.
- Before cleaning the unit, turn off the power and unplug the AC adaptor from the outlet (p. 12).
- Whenever you suspect the possibility of lightning in your area, disconnect the AC adaptor from the outlet.
- If used improperly, batteries may explode or leak and cause damage or injury. In the interest of safety, please read and observe the following precautions.
  - Carefully follow the installation instructions for batteries, and make sure you observe the correct polarity.
  - Avoid using new batteries together with used ones. In addition, avoid mixing different types of batteries.
  - Remove the batteries whenever the unit is to remain unused for an extended period of time.
  - If a battery has leaked, use a soft piece of cloth or paper towel to wipe all remnants of the discharge from the battery compartment. Then install new batteries. To avoid inflammation of the skin, make sure that none of the battery discharge gets onto your hands or skin. Exercise the utmost caution so that none of the discharge gets near your eyes. Immediately rinse the affected area with running water if any of the discharge has entered the eyes.
- Never keep batteries together with metallic objects such as ballpoint pens, necklaces, hairpins, etc.
- Used batteries must be disposed of in compliance with whatever regulations for their safe disposal that may be observed in the region in which you live.
- Should you remove stand holder mounting screws, make sure to put them in a safe place out of children's reach, so there is no chance of them being swallowed accidentally.

# IMPORTANT NOTES

In addition to the items listed under "USING THE UNIT SAFELY" on page 2–3, please read and observe the following:

## Power Supply: Use of Batteries

- Do not use this unit on the same power circuit with any device that will generate line noise (such as an electric motor or variable lighting system).
- The AC adaptor will begin to generate heat after long hours of consecutive use. This is normal, and is not a cause for concern.
- The use of an AC adaptor is recommended as the unit's power consumption is relatively high. Should you prefer to use batteries, please use the alkaline type.
- When installing or replacing batteries, always turn off the power on this unit and disconnect any other devices you may have connected. This way, you can prevent malfunction and/or damage to speakers or other devices.
- Batteries are supplied with the unit. The life of these batteries may be limited, however, since their primary purpose was to enable testing.
- Before connecting this unit to other devices, turn off the power to all units. This will help prevent malfunctions and/or damage to speakers or other devices.

## Placement

- Using the unit near power amplifiers (or other equipment containing large power transformers) may induce hum. To alleviate the problem, change the orientation of this unit; or move it farther away from the source of interference.
- This device may interfere with radio and television reception. Do not use this device in the vicinity of such receivers.
- Do not expose the unit to direct sunlight, place it near devices that radiate heat, leave it inside an enclosed vehicle, or otherwise subject it to temperature extremes. Excessive heat can deform or discolor the unit.
- To avoid possible breakdown, do not use the unit in a wet area, such as an area exposed to rain or other moisture.

## Maintenance

- For everyday cleaning wipe the unit with a soft, dry cloth or one that has been slightly dampened with water. To remove stubborn dirt, use a cloth impregnated with a mild, non-abrasive detergent. Afterwards, be sure to wipe the unit thoroughly with a soft, dry cloth.
- Never use benzine, thinners, alcohol or solvents of any kind, to avoid the possibility of discoloration and/or deformation.

## Additional Precautions

- Please be aware that the contents of memory can be irretrievably lost as a result of a malfunction, or the improper operation of the unit. To protect yourself against the risk of losing important data, we recommend that you write down important data on paper.
- Unfortunately, it may be impossible to restore the contents of data that was stored in the unit's memory once it has been lost. Roland Corporation assumes no liability concerning such loss of data.
- Use a reasonable amount of care when using the unit's buttons, sliders, or other controls; and when using its jacks and connectors. Rough handling can lead to malfunctions.
- When connecting / disconnecting all cables, grasp the connector itself—never pull on the cable. This way you will avoid causing shorts, or damage to the cable's internal elements.
- To avoid disturbing your neighbors, try to keep the unit's volume at reasonable levels. You may prefer to use headphones, so you do not need to be concerned about those around you (especially when it is late at night).
- This instrument is designed to minimize the extraneous sounds produced when it's played. However, since sound vibrations can be transmitted through floors and walls to a greater degree than expected, take care not to allow these sounds to become a nuisance to neighbors, especially when performing at night and when using headphones.
- When you need to transport the unit, package it in the box (including padding) that it came in, if possible. Otherwise, you will need to use equivalent packaging materials.
- Do not strike the pads extremely strong. Be careful to prevent your fingers or hands from injury.

# Contents

|   |           |
|---|-----------|
| <b>USING THE UNIT SAFELY .....</b>                          | <b>2</b>  |
| <b>IMPORTANT NOTES .....</b>                                | <b>4</b>  |
| <b>Contents .....</b>                                       | <b>5</b>  |
| <b>Main Features .....</b>                                  | <b>7</b>  |
| <b>Parts of the SPD-6 and Their Function .....</b>          | <b>8</b>  |
| <b>What Is a Patch? .....</b>                               | <b>10</b> |
| <b>Preparations .....</b>                                   | <b>11</b> |
| Check the Contents of the Box.....                          | 11        |
| Install Batteries.....                                      | 11        |
| About the Auto Power Off Function .....                     | 12        |
| Defeating the Auto Power Off Function .....                 | 12        |
| Using the AC Adaptor .....                                  | 12        |
| Holding the SPD-6.....                                      | 13        |
| Attaching the SPD-6 to a Stand .....                        | 13        |
| Connecting Audio System, or Amp.....                        | 14        |
| Connecting Headphones .....                                 | 14        |
| Connecting a Pedal Switch.....                              | 15        |
| Example of Using Pedal Switch 1 .....                       | 15        |
| Turning the Power On.....                                   | 16        |
| Turning the Power Off .....                                 | 17        |
| <b>Playing .....</b>  | <b>18</b> |
| Playing the SPD-6.....                                      | 18        |
| Select a Patch.....   | 18        |
| Try Selecting Various Patches .....                         | 19        |
| <b>Basic Rhythms for Playing With Other Musicians.....</b>  | <b>20</b> |
| Playing an 8-Beat Rhythm Pattern.....                       | 20        |
| Playing an 8-Beat Fill-in Pattern.....                      | 20        |
| Playing a Salsa Rhythm .....                                | 21        |
| Playing a Samba Rhythm .....                                | 21        |
| <b>Creating Your Own Patch.....</b>                         | <b>22</b> |
| <b>Make Settings for the Pad and the Pedal Switch .....</b> | <b>24</b> |
| Pad Velocity Curve .....                                    | 24        |
| Pedal Switch Velocity .....                                 | 24        |
| <b>Settings for the Entire SPD-6 (System).....</b>          | <b>25</b> |
| Trigger Threshold.....                                      | 25        |
| Trigger Sensitivity (Hand/Stick) .....                      | 25        |

## Contents

|   |           |
|---|-----------|
| <b>Features Using MIDI .....</b>  | <b>26</b> |
| Connecting the SPD-6 to an External MIDI Sound Module.....                          | 26        |
| Other Ways to Use the SPD-6 .....   | 26        |
| How the Sounds Are Produced.....  | 27        |
| Creating Your Own Patch .....   | 27        |
| Make Settings for Each Patch.....   | 28        |
| Specifying the Combination of Program Change and Bank Select to be Transmitted..... | 28        |
| Input the Program Change and Bank Select MSB/LSB .....                              | 29        |
| Make Settings for Each Pad .....  | 30        |
| Changing the Transmitted Note Numbers.....  | 30        |
| Setting the Gate Time .....   | 31        |
| <b>Troubleshooting.....</b>   | <b>32</b> |
| Problems Concerning the Entire SPD-6 .....  | 32        |
| MIDI-Related Problems .....   | 32        |
| Error Message List.....   | 32        |
| <b>Restoring the Factory Settings (Factory Reset) .....</b>                         | <b>33</b> |
| <b>Patch List (Preset Group).....</b>   | <b>34</b> |
| When Playing the Internal Sounds of the SPD-6 .....                                 | 34        |
| When Playing a Drum Set of an External MIDI Sound Module (Via MIDI).....            | 36        |
| <b>Internal Sounds List .....</b>   | <b>38</b> |
| <b>About MIDI .....</b>   | <b>39</b> |
| About MIDI OUT Connector.....   | 39        |
| About General MIDI/General MIDI 2/GS.....   | 39        |
| <b>MIDI Implementation.....</b>   | <b>40</b> |
| <b>Specifications.....</b>  | <b>42</b> |
| <b>Operation List.....</b>  | <b>43</b> |
| Power-on Functions .....  | 43        |
| Edit Functions .....  | 43        |
| <b>Blank Chart.....</b>   | <b>44</b> |
| <b>Index.....</b>   | <b>46</b> |

# Main Features

The SPD-6 is a compact, lightweight percussion pad that you can play with either your hands or with drum sticks.

## Select From 32 Patches

---

The SPD-6 contains a total of 32 patches: 16 patches whose settings cannot be modified (the preset group), and 16 patches whose settings you can modify (the user group).

The patches of the preset group include conventional drum sets, conga and bongo sets, and sound effect sets.

## Selecting and Playing Your Favorite Percussion Instruments or Sound Effects

---

Sixteen of the 32 are User (you!) patches allowing you to select a different sound for each of the six pads, to create your personalized patch.

Select your favorites from the 113 different sounds built into the SPD-6.

## Other Ways to Use the SPD-6

---

### Play Sound Effects Available Only on Electronic Musical Instruments



The SPD-6 can play not only drums and percussion, but also sound effects. This can be helpful in recording or performing.

### Use the SPD-6 As an Addition to Electronic or Acoustic Drums

The SPD-6 can also be used with electronic drum sets or acoustic drums.

By connecting the SPD-6 via MIDI to an external sound module or an electronic drum set use it to play other drum/percussion sounds. Or use the SPD-6 connected to an amp playing the internal sounds as an addition to your acoustic drums.

### Easy Connection to General MIDI 2 ( )/GS ( ) Devices

By using a MIDI cable to connect to a sound module carrying the General MIDI 2 (  )/GS (  ) logos, you can simply select a patch and start playing the SPD-6.

### Using the SPD-6 With Your Computer to Make Music

Since you can specify the note number, program change, and bank select, the SPD-6 is ideal for use with computer based music systems.

### Play Ensembles with an Electronic Piano

Enjoy ensemble playing with various instruments by sounding the drum set of an electronic piano or other instrument, or by using the internal sounds of the SPD-6.

Use audio cables or the included MIDI cable to connect the SPD-6 to your MIDI device.

# Parts of the SPD-6 and Their Function

## Front Panel

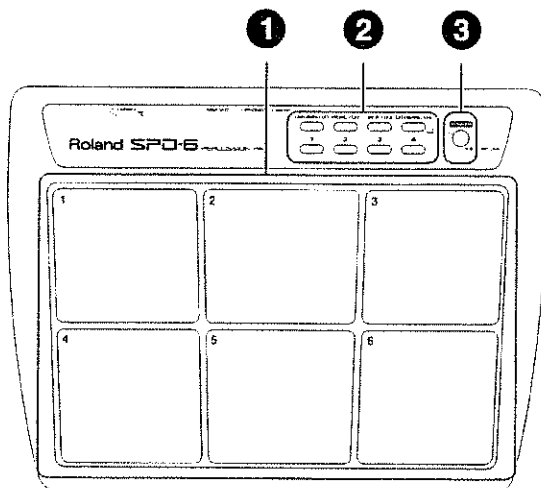

### 1 Pads 1–6

There are six pads; pad 1– pad 6 each pad corresponds to the sounds of the selected patch.

### 2 Patch select buttons

Use the four buttons of the upper row and the four buttons of the lower row to select patches (p. 18).

For advanced operation, these buttons are used to select parameters or values (p. 26).

### 3 [POWER] button

This button turns the power of the SPD-6 on or off (p. 16).

## Bottom Panel

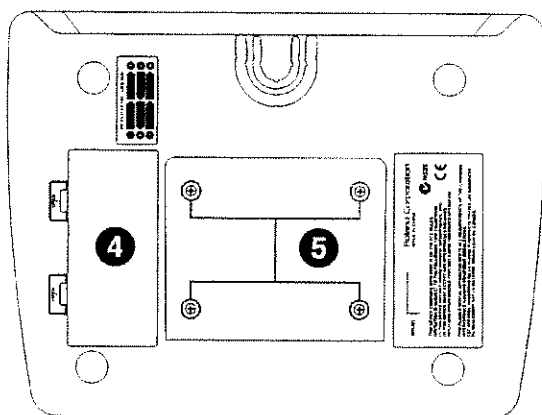

### 4 Battery cover

Open this cover to insert or replace the batteries (p. 11).

### 5 Stand holder mounting screw

Use this when mounting the SPD-6 on a Pad Stand (sold separately: PDS-15) or All Purpose Clamp (sold separately: APC-33) (p. 13).

The screws included with the PDS-15 or APC-33 cannot be used. You must use the stand holder mounting screw.



## Rear Panel

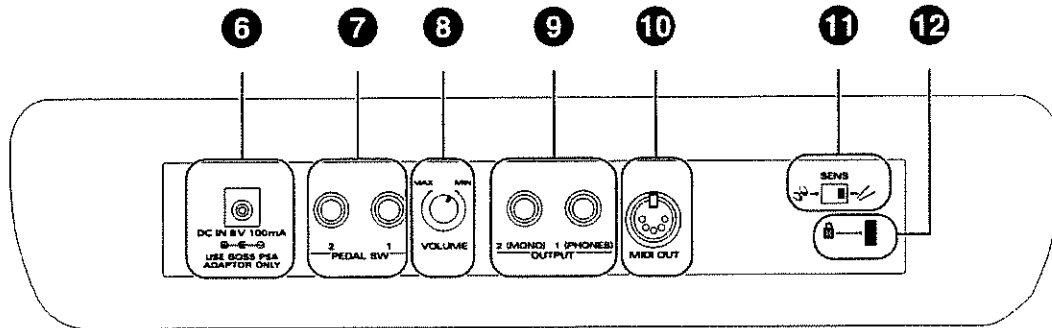

### 6 AC adaptor jack

When using the separately sold AC Adaptor BOSS PSA series, connect it to this jack (p. 12).

### 7 [PEDAL SW] jacks

Pedal switches (sold separately: DP-2) or foot switches (sold separately: BOSS FS-5U) can be connected here to play sounds (p. 15).

### 8 [VOLUME] knob

This knob adjusts the volume of the SPD-6's internal sounds (p. 17).

### 9 [OUTPUT] 1 (PHONES)/2 (MONO) jacks

These jacks output the internal sounds of the SPD-6, and are for connection to external audio devices or amps (p. 14).

If using a single cable for monaural output, you must use the "2 (MONO)" jack.



If using headphones, connect them to the "1 (PHONES)" jack (p. 14). When you use headphones, do not connect anything to the "2 (MONO)" jack.

\* The internal sounds of the SPD-6 will be output in monaural.

### 10 MIDI OUT connector

Connect a MIDI cable to this connector when making connections to an external MIDI device (p. 26).

### 11 [SENS] select switch

This sets the sensitivity of the pads, as you may play with sticks or your hand (p. 18). For hands, set this to the  position. For drumsticks, set this to the  position.

### 12 MicroSaver Security Slot ( )

MicroSaver and Kensington are registered trademarks of Kensington Microware Limited.

© 1997 Kensington Microware Limited

Kensington Microware Limited

2855 Campus Drive

San Mateo, CA 94403 U.S.A.

Web:www.kensington.com

# What Is a Patch?

A patch is a collection of the eight sounds that are played when you strike the six pads or press a pedal switch (sold separately).

The SPD-6 contains a total of 32 patches: 16 patches whose settings cannot be modified (**the preset group**), and 16 patches whose settings you can modify (**the user group**). The selection of whether you will play using preset or user patches is made when you turn on the power of the SPD-6 (p. 16).

For the sounds of the patches in the preset group, refer to "Patch List (Preset Group)" (p. 34).

## Example Patch ("DRUMS-1" of the Preset Group)

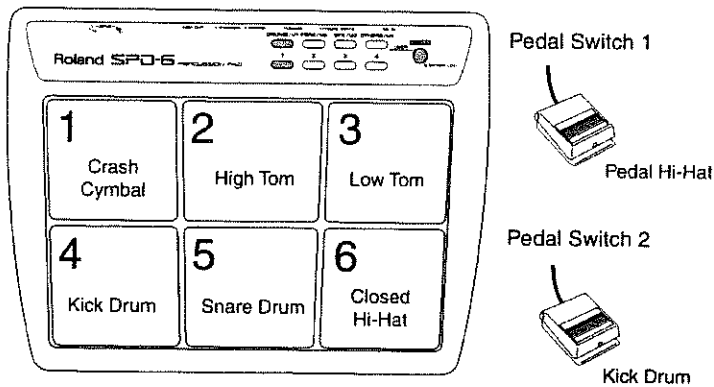

## About the Patch Name

The patch name is shown (for example) as DRUMS-1 or U2-2.

Preset Group: Press the [POWER] button to turn on the power

DRUMS - 1  
↑ Press the [1] button  
Press [DRUMS/U1]

User Group: Hold down the [OTHERS/U4] button and press the [POWER] to turn on the power

U2 - 2  
↑ Press the [2] button  
Press [PERC/U2]

# Preparations

## Check the Contents of the Box

- SPD-6
- MIDI cable
- Dry battery (R6 (AA) type) x 6
- Stand holder mounting screw x 4  
\* Attached to the bottom panel (p. 8)
- Owner's Manual (this manual)

## Install Batteries

Install the included batteries.

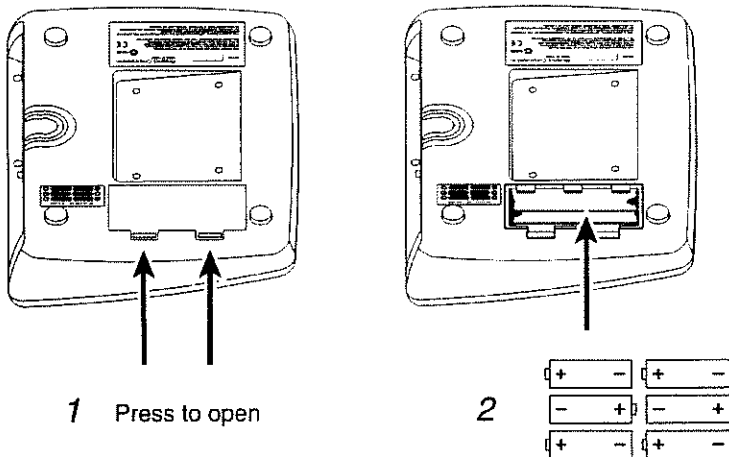

- 1** Open the battery cover (p. 8) located on the back of the SPD-6.
- 2** Insert the six included dry batteries (R6 (AA) type) in the orientation shown by the diagram.



Be careful to observe the correct polarity (+, - direction) of the batteries.

- 3** Close the battery cover.



### Using an AC adaptor (p. 12)

If an AC adaptor is desired, use the separately sold AC adaptor BOSS PSA series.



### Expected battery life under continuous use:

Carbon: 8 hours

Alkaline: 20 hours

*These figures will vary depending on the actual conditions of use.*



- When operating on battery power only, the [POWER] button will blink when battery power gets too low. Replace the battery as soon as possible.
- The settings of the SPD-6 will be remembered even if the batteries run down.

## Preparations

# About the Auto Power Off Function

The power will turn off automatically if the SPD-6 is not used for approximately 10 minutes.

To play the SPD-6, turn on the power once again (p. 16).

## Defeating the Auto Power Off Function

You can defeat the Auto Power Off function by using the following procedure to turn on the SPD-6.

### If playing the preset group patches

Hold down [DRUMS/U1] and press [POWER] to turn on the power.

### If playing the user group patches

Hold down [DRUMS/U1] and [OTHERS/U4], and press [POWER] to turn on the power.



- When using the SPD-6 with batteries, we recommend that you use the Auto Power Off function in order to conserve the batteries.
- The Auto Power Off function is also in effect even when the AC adaptor is used.

## Using the AC Adaptor

You can use a separately sold AC Adaptor BOSS PSA series.

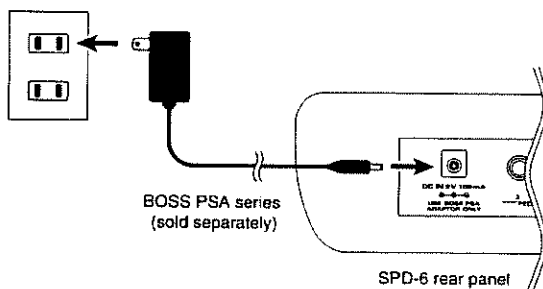

Use only the specified AC Adaptor BOSS PSA series. To purchase this adaptor, contact the dealer where you purchased the SPD-6.

1

Turn off the power of all devices before you make connections.



To prevent malfunction and/or damage to speakers or other devices, always turn down the volume, and turn off the power on all devices before making any connections.

2

Connect the separately sold AC Adaptor BOSS PSA series to the AC adaptor jack (p. 9).

3

Plug the AC adaptor into an AC outlet.

## Holding the SPD-6

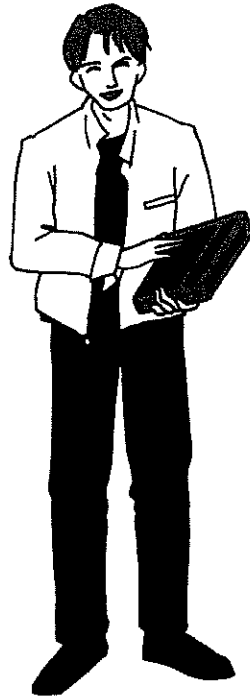

Hold it with your hand



Put it on your lap

**NOTE**

Rubber feet are attached to the bottom side of the SPD-6, but when placing it on a surface such as a table or electronic piano, you should still be careful not to scratch the surface.

## Attaching the SPD-6 to a Stand

You can use a pad stand (sold separately: PDS-15) to set up the SPD-6.

By using the all purpose clamp (sold separately: APC-33), you can attach the SPD-6 to a commercially available tom stand or cymbal stand. It can be attached to a pipe of 10.5 mm–30 mm radius.

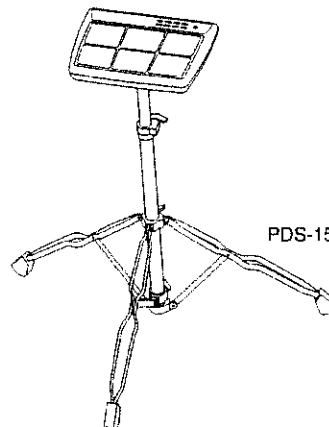
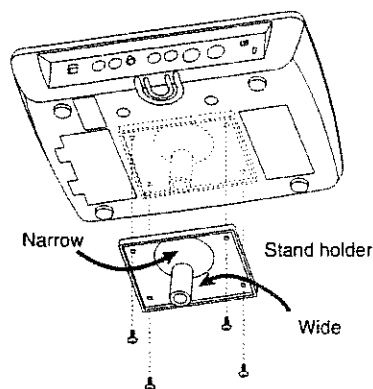

**NOTE**

- The screws included with the PDS-15 or APC-33 cannot be used. To attach the stand holder, remove the four screws from the bottom of the SPD-6 and use them.
- Never attach the SPD-6 to an unstable stand or a stand that is insufficiently strong. It may fall over and damage your equipment or cause personal injury.

## Preparations

# Connecting Audio System, or Amp

The internal sounds of the SPD-6 will be output in monaural.

1

Before making connections, turn off the power of all devices.

**NOTE**

To prevent malfunction and/or damage to speakers or other devices, always turn down the volume, and turn off the power on all devices before making any connections.

2

Use an audio cable to connect the [OUTPUT] jack(s) on the rear panel of the SPD-6 to the input jack(s) of your audio system or amp.

If using one monaural cable to make connections, connect the SPD-6's [OUTPUT] 2 (MONO) jack to the "MONO" jack of your audio system or amp.

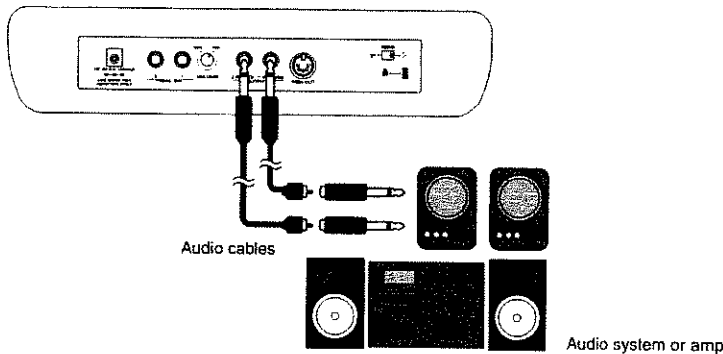

When using one cable for connections

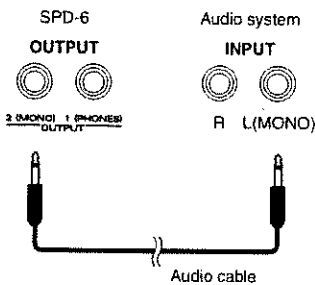

When using two cables for connections

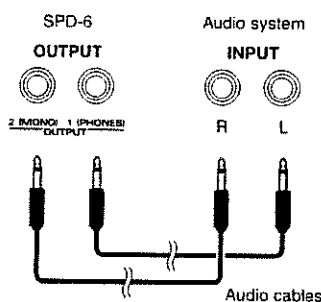

# Connecting Headphones

1

Connect headphones to the [OUTPUT] 1 (PHONES) jack on the rear panel of the SPD-6.

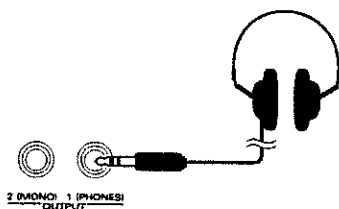

**NOTE**

If you are using headphones, do not connect anything to the [OUTPUT] 2 (MONO) jack.

## Connecting a Pedal Switch

Pedal switches (sold separately: DP-2) or foot switches (sold separately: BOSS FS-5U) can be used as follows.

### Connect to the [PEDAL SW] 1 jack

- When you press the pedal switch, the selected sound will be heard.
- Switch the sound of the pad for which closed hi-hat was selected. This allows you to play both open, pedal and closed hi-hat sounds (like a real hi-hat).

### Connect to the [PEDAL SW] 2 jack

- When you press the pedal switch, the selected sound will be heard.

1

Connect pedal switches to the [PEDAL SW] 1/2 jacks on the rear panel of the SPD-6.

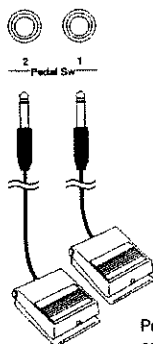

Pedal Switch (sold separately: DP-2)  
or Foot Switch (sold separately: BOSS FS-5U)

## Example of Using Pedal Switch 1

When DRUMS-1 of the preset group is selected, you can play as follows.

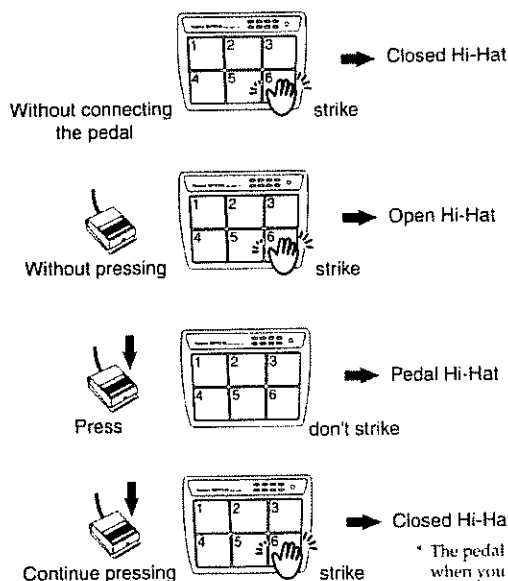

\* The pedal hi-hat sound will be heard when you depress the pedal. If you do not want to play the sound, refer to p. 23.



To control the opening/closing of the hi-hat using pedal switch 1, assign the internal sounds "49 Pedal Hi-Hat," "51 808 Closed Hi-Hat 1," "52 808 Closed Hi-Hat 2," or "114 Off" to pedal switch 1.



You can also control the opening/closing of the hi-hat when using the SPD-6 to sound an external MIDI sound generator (p. 30).



Roland recommends that you use a DP-2 pedal switch or a BOSS FS-5U foot switch. Other brand foot switches may not operate correctly. Inquire about this at the store where you purchased the SPD-6.



For the procedure of selecting DRUMS-1 of the preset group and for more details, refer to p. 18.

## Preparations

# Turning the Power On

### NOTE

Once the connections have been completed (p. 14), turn on power to your various devices in the order specified. By turning on devices in the wrong order, you risk causing malfunction and/or damage to speakers and other devices.

1

Turn the [VOLUME] knob on the rear panel of the SPD-6 all the way toward the left, setting the volume to the minimum position.

SPD-6 [VOLUME] Knob

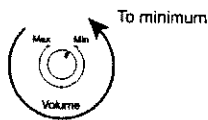

2

Turn the volume down to the minimum on the connected amp or audio system.

3

Turn on the power of the SPD-6.

#### When playing preset group patches

Press [POWER] to turn on the power.

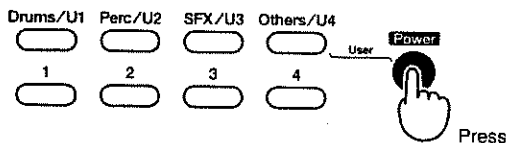

#### When playing user group patches

Hold down [OTHERS/U4] and press [POWER] to turn on the power.

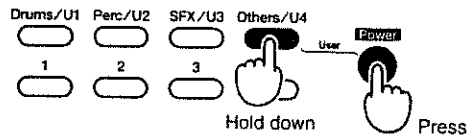

4

Turn on the power of the connected amp or audio system.

### NOTE

This unit is equipped with a protection circuit. A brief interval (a few seconds) after power up is required before the unit will operate normally.

### NOTE

#### When playing a drum set of a MIDI sound module

To specify the drum set used by the MIDI sound module, select a patch on the SPD-6.



5

While playing sounds on the SPD-6, adjust the volume of the connected amp or audio system.

SPD-6 [VOLUME] Knob

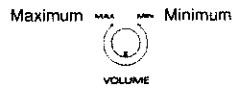

### Caution When Turning on the Power

After turning on the power, touch the pads or pedals until the [DRUMS/U1] button and [1] button light as shown in the following diagram.

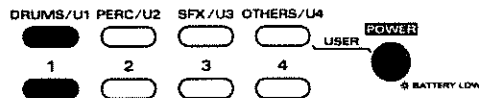

If you touch the pads or pedals before the buttons light, you may experience problems like no sound, or low volume.

## Turning the Power Off

1

Completely turn down the volume of the SPD-6 and any connected external devices.

2

Turn off the power to all external devices.

3

Hold down the SPD-6's [POWER] button for at least a second to turn off the power.



To prevent the power from being turned off accidentally while you are playing the SPD-6, the power is not switched off unless you hold down [POWER] for at least a second.

# Playing

## Playing the SPD-6

The SPD-6 can be struck either with your hand or with drumsticks. Set the rear panel [SENS] select switch (p. 9) to the appropriate setting for the playing method you choose.

When using your hand to play the SPD-6

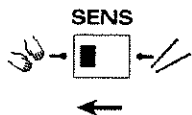

When using drumsticks to play the SPD-6

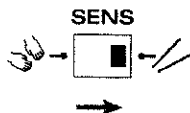

It is possible to make even finer sensitivity adjustments (p. 25).

### Please Note When Playing

- To play the SPD-6, you must accurately strike the center of the pad. If you strike the edge of the pad, a different pad may sound.
- Do not strike the case, buttons, or any other areas other than the pads. Doing so may result in malfunction.

## Select a Patch

As an example, here's how to select preset group DRUMS-1, a patch that lets you play a conventional drum set.

1

Press [DRUMS/U1].

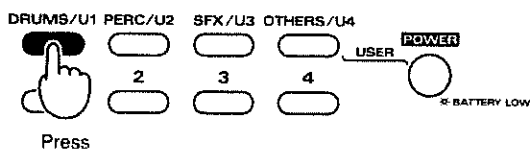

2

Press [1].

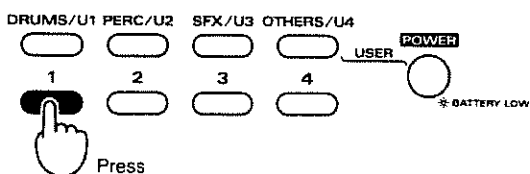

A maximum of four internal sounds can be played simultaneously. If you attempt to play more than four sounds, currently sounding sounds will be turned off, beginning with the one being sounded with the least volume.

## Try Selecting Various Patches

The SPD-6 has 16 patches of the preset group. Let's try playing various patches.



For a list of the sounds in each patch, refer to p. 34.

### The Patches of the Preset Group

**(press [POWER] to turn on the power)**

| Patch name |                            | Description  |
|------------|----------------------------|--|
| DRUMS-1    | Drum Standard              | Conventional drum sounds                                       |
| DRUMS-2    | Drum Power                 | Powerful drum sounds   |
| DRUMS-3    | Drum Brush                 | Drums played with brushes                                      |
| DRUMS-4    | TR-808 (Analog)            | Sounds from older rhythm machines                              |
| PERC-1     | Conga and Bongo            | Conga, Bongo   |
| PERC-2     | Timbales                   | Timbales, Wood Block, Cowbell                                  |
| PERC-3     | Samba                      | Cuica, Agogo, Surdo etc.                                       |
| PERC-4     | Latin Toys                 | Triangle, Guiro, Vibra-Slap etc.                               |
| SFX-1      | Dance                      | Sound effects (Slap, Scratch etc.)                             |
| SFX-2      | Human                      | Sound effects (Foot Step, Heart Beat, Screaming, Door etc.)    |
| SFX-3      | Crash                      | Sound effects (Car-Engine, Car-Crash, Gun Shot etc.)           |
| SFX-4      | Kids                       | Sound effects (Dog, Kitty, Laughing, Thunder etc.)             |
| OTHERS-1   | Drum with Pedal            | Conventional drum sounds (use a pedal switch as the kick drum) |
| OTHERS-2   | Drum Electronic            | Electronic drum sounds   |
| OTHERS-3   | Cymbal Set                 | Various types of cymbal sounds                                 |
| OTHERS-4   | TR-808 (Analog)<br>Tom Set | Various types of tom sounds                                    |

# Basic Rhythms for Playing With Other Musicians

## Playing an 8-Beat Rhythm Pattern

Let's use the preset group DRUMS-1 patch to practice an 8-beat rhythm pattern.  
 Try playing the pads according to the number chart shown in the music score.

Number Chart:

|   |   |   |
|---|---|---|
| 1 | 2 | 3 |
| 4 | 5 | 6 |

Right Hand: ⑥ ⑥ ⑥ ⑥ ⑥ ⑥ ⑥ ⑥ ⑥ ⑥ ⑥ ⑥ ⑥ ⑥ ⑥ ⑥

Left Hand: ④ ⑤ ④ ④ ⑤ ④ ⑤ ④ ④ ⑤

Labels: Closed Hi-Hat, Snare Drum, Kick Drum



When you have a pedal switch connected to the [PEDAL SW] 1 jack  
 Continue pressing the pedal switch to play the closed hi-hat sound.



**8-beat:**  
 This refers to a rhythm that divides four beats into eighth notes. The accent occurs on the second and fourth beats. This is the basic of rock rhythm patterns.

## Playing an 8-Beat Fill-in Pattern

When you are able to play the 8-beat, pattern, try playing along with someone playing the piano or organ. (or any other instrument of course)  
 Try playing a fill-ins as well, using different sounds.

Number Chart:

|   |   |   |
|---|---|---|
| 1 | 2 | 3 |
| 4 | 5 | 6 |

Right Hand: ① ⑥ ⑥ ⑥ ⑥ ⑥ ⑥ ⑥ ⑥ ⑥ ⑥ ⑥ ② ② ③ ③

Left Hand: ④ ⑤ ④ ④ ⑤ ④ ⑤ ④ ④ ⑤

Labels: Crash Symbol, Closed Hi-Hat, High Tom, Low Tom, Snare Drum, Kick Drum



**Fill-in:**  
 A performance technique used mainly in between phrases and/to create dynamics.

## Playing a Salsa Rhythm

Use preset group PERC-1 to practice a salsa rhythm.

The musical notation shows two staves: Bongo and Claves, both in 4/4 time. The Bongo staff has a rhythmic pattern of eighth notes. The Claves staff has a pattern of quarter notes and eighth notes.

Below the notation is a diagram of a bongo set with a 2x3 grid of buttons numbered 1-6. To the right, the right hand sequence is: (2) (2) (2) (2) (2) (2) (3) (2) (2) (2) (2) (2) (2) (3) (2). The left hand sequence is: (1) (1) (1) (1) (1). Brackets indicate that the right hand sequence is for High Bongo and Low Bongo, and the left hand sequence is for Claves.



**Salsa:**

A style of music that originated in Cuba. Its "feature" is a basic pattern played on a cowbell or claves.

## Playing a Samba Rhythm

Use preset group PERC-3 to practice a samba rhythm.

The musical notation shows two staves: Surdo and Agogo, both in 4/4 time. The Surdo staff has a pattern of quarter notes with '+' and 'o' markings above them. The Agogo staff has a pattern of eighth notes.

Below the notation is a diagram of a bongo set with a 2x3 grid of buttons numbered 1-6. To the right, the right hand sequence is: (6) (3) (6) (3). The left hand sequence is: (5) (5) (2) (5) (5) (2) (2). Brackets indicate that the right hand sequence is for Mute Surdo and Open Surdo, and the left hand sequence is for High Agogo and Low Agogo.



**Samba:**

A cheerful two-beat rhythm that originated in Brazil. Its "feature" is the rhythm of the agogo.

# Creating Your Own Patch

There are 16 patches that allow you to choose the sound played on each pad/pedal (User Group).

When you have become familiar with the SPD-6, you can create your very own patches by changing the internal sounds that are played when you strike the pads. You can listen to various percussion instrument sounds and sound effects, and choose your favorite ones to create the desired patch.

**1**

Hold down [OTHERS/U4] and press [POWER] to turn on the power (User Group).

**2**

Press and hold down the two buttons of the user patch that you wish to edit, and release them when [OTHERS/U4], [1], [2] and [3] begin to blink.

Example: When making settings for U1-1

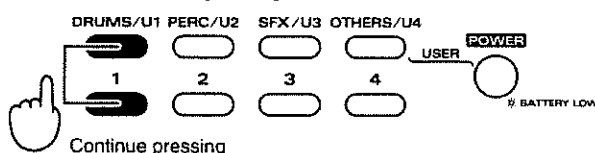

**3**

Press [1].

[OTHERS/U4] begins flashing, and one of the [1]–[4] buttons lights.

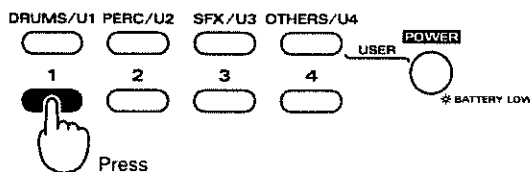

**4**

Strike a pad to select the pad whose sound you wish to change.

Strike the center of the pad accurately, and slightly harder than usual.

Only one of the buttons [1]–[4] will light according to the struck pad or pedal switch setting.

|                 | [1]         | [2]         | [3]        | [4]             |
|-----------------|-------------|-------------|------------|-----------------|
| Internal sounds | Kick, Snare | Tom, Cymbal | Percussion | Dance, SFX, Off |



If you become unable to make settings as desired, you can cancel all current settings of the SPD-6 and return it to the factory-set condition (Factory Reset; p. 33).



The internal sounds of the SPD-6 are shown in the "Internal Sounds List" (p. 38).



To cancel the operation, press [OTHERS/U4] (flashing). The user patch you selected in step 2 can now be played.

## 5

Make the setting for the pad that you selected in step 4.

You can strike the pad to hear the currently selected sound.

The internal sounds will be heard when you operate the buttons, pads, or pedals.

| Operation        | Amount of change   | Range of available instrument numbers | Internal Sounds |
|------------------|--|---------------------------------------|-----------------|
| Press [1]        | Increases by one; after reaching the maximum value, returns to the minimum value | 1-23                                  | Kick, Snare     |
| Press [2]        |  | 24-60                                 | Tom, Cymbal     |
| Press [3]        |  | 61-89                                 | Percussion      |
| Press [4]        |  | 90-114                                | Dance, SFX, Off |
| Press [DRUMS/U1] | Decreases by one; stops at the minimum value                                     | 114-1                                 | All sounds      |
| Press [PERC/U2]  | Increases by one; stops at the maximum value                                     | 1-114                                 | All sounds      |

- The last-played internal sound will be assigned to that pad or pedal switch.
- Continue holding down the button, and the value changes consecutively.
- If you press an unlit button [1]-[4], the minimum internal sound number value that can be set for each button will be set.
- If you hold down [PERC/U2] and press [DRUMS/U1], the value will increase rapidly. If you hold down [DRUMS/U1] and press [PERC/U2], the value will decrease rapidly.

## 6

Repeat steps 4 and 5.

To make settings for a pedal switch, press that pedal switch instead of striking a pad in each step.

When you have finished making settings for all pads, proceed to step 7.

## 7

Press [OTHERS/U4] to save the settings.

After the button flashes, you can perform using the edited settings.



### Canceling changes BEFORE saving

- When you wish to play immediately
  - Hold down [SFX/U3] and press [OTHERS/U4]. After the button corresponding to the value of the setting prior to editing is flashing, the patch you selected in step 2 can be played in its unedited state.
- When you wish to turn off the power
  - Press [POWER] to turn off the power. When you hold down [OTHERS/U4] and turn on the power once again and select the user patch, it can be played in its unedited state.



- When the closed hi-hat sound is assigned to a pad, you can open & close the hi-hat (p. 15) using a pedal switch (DP-2; optionally available). To use this function, assign the internal sounds "49 Pedal Hi-Hat," "51 808 Closed Hi-Hat 1," "52 808 Closed Hi-Hat 2," or "114 Off" to pedal switch 1.
- If you do not want sound to be heard when you press the pedal switch used to control the hi-hat, assign the internal sound "114 Off."



After pressing [OTHERS/U4], make sure you do not turn off the power until after the buttons of the edited patch have lit.

# Make Settings for the Pad and the Pedal Switch

For each pad or pedal, you can adjust the pad velocity curve, and pedal switch velocity.

You can make independent settings for each of the sixteen user patches.



When making these settings, the Auto Power Off function is disabled.

1. Press [POWER] to turn off the power of the SPD-6.
2. Hold down the two buttons of the user patch that you wish to edit, and press the [POWER] to turn on the power.  
The two buttons of the user patch to be edited flash.



To cancel the operation, press [OTHERS/U4]. The user patch you selected can now be played.

3. Hold down [DRUMS/U1] and press [1].  
[OTHERS/U4] flashes, and [DRUMS/U1] and one of the [1]–[4] buttons light.
4. Strike a pad to select the pad that you wish to edit.  
Strike the center of the pad accurately, and slightly harder than usual.  
To make settings for a pedal switch, press that pedal switch instead of striking a pad in each step.  
Only one of the buttons [1]–[4] will light according to the struck pad or pedal switch setting.
5. Refer to the following diagram, and press [1]–[4] to make settings.

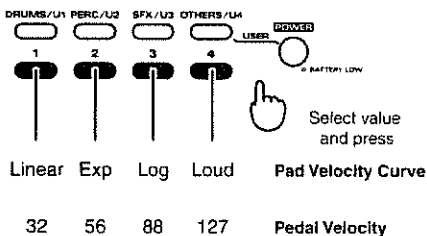

6. Repeat steps 4 and 5.  
When you have finished making settings for all pads, proceed to step 7.
7. Press [OTHERS/U4] (flashing) to save the edited value.  
After the button you selected flashes, you will once again be able to select a parameter (the state of step 2).



Do not turn off the power after pressing [OTHERS/U4] until after the buttons of the patch that you selected in step 2 have flashed.



## Canceling changes BEFORE saving

- If you wish to continue and set other parameters, hold down [SFX/U3] and press [OTHERS/U4]. After the button corresponding to the value of the setting prior to editing is

flashing, you will be able to select the desired parameter. (The two buttons of the user patch that you selected in step 2 flash.)

- If you wish to turn off the power, press [POWER].

8. When you have finished making all settings, press [OTHERS/U4].

Now you can play the user patch that you edited.

## Pad Velocity Curve

This setting adjusts how your playing dynamics affects the volume of the sound being played.

The factory setting is “Linear.”

**Range: Linear, Exponential (Exp), Log, Loud**

### Linear

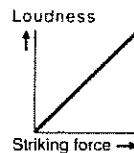

### Exponential

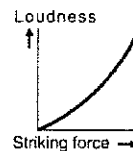

### Log

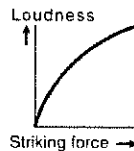

### Loud

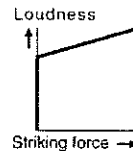

**Linear:** The standard setting. This produces the most natural correspondence between playing dynamics and changes in volume.

**Exponential:** Compared to Linear, the harder you play the change will be more obvious.

**Log:** Compared to Linear, a soft strike will produce a greater change.

**Loud:** Variation in striking force will produce little change, and a constant volume will be maintained.

## Pedal Switch Velocity

You can adjust the volume of the sound assigned to the pedal switch.

The factory setting is “88.”

**Range: 32, 56, 88, 127**



If you do not want sound to be heard when you press the pedal switch used to control the hi-hat, assign it to a note number that produces no sound, or turn the internal sound “114 Off.”



# Settings for the Entire SPD-6 (System)

Here you can make settings for Trigger Threshold and Trigger Sensitivity. For these parameters, a single setting is shared by the entire SPD-6.



When making these settings, the Auto Power Off function is disabled.

1. Press [POWER] to turn off the power of the SPD-6.
2. Hold down [DRUMS/U1] and [1], and press the [POWER] button to turn on the power. [DRUMS/U1] and [1] flash.



- You can make the system settings regardless of the patch you selected.
- To cancel the operation, press [OTHERS/U4]. The user patch you selected can now be played.

3. Refer to the following table, and select the parameter that you wish to edit.

| Parameter                   | SPD-6 operation               |
|-----------------------------|-------------------------------|
| Trigger Threshold           | Press [SFX/U3] and press [1]. |
| Trigger Sensitivity (Hand)  | Press [SFX/U3] and press [2]. |
| Trigger Sensitivity (Stick) | Press [SFX/U3] and press [3]. |

[OTHERS/U4] flashes, and [SFX/U3] lights. Only one of the buttons [1]–[4] will light according to the setting.

4. Set the parameter that you selected in step 3. Refer to the following diagram, and press [1]–[4] to make settings.

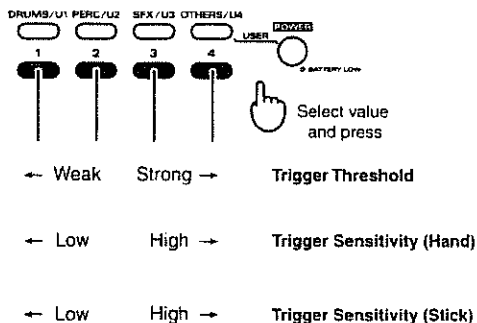

5. Press [OTHERS/U4] (flashing) to save the edited value. After the button you selected flashes, you will once again be able to select a parameter (the state of step 2).



Do not turn off the power after you press [OTHERS/U4] until [DRUMS/U1] and [1] have flashed.



## Canceling changes BEFORE saving

- If you wish to continue and set other parameters, hold down [SFX/U3] and press [OTHERS/U4]. After the button corresponding to the value of the setting prior to editing is flashing, you will be able to select the desired parameter. ([DRUMS/U1] and [1] flash.)
  - If you wish to turn off the power, press [POWER].
6. If you wish to edit other parameters, repeat steps 3–5.
  7. When you have finished making all settings, press [OTHERS/U4].  
Now you can play the user patch that you edited.

## Trigger Threshold

This setting causes the sound to be played only by a strike of the specified force or greater.

If you set this to a high value, it will be difficult to play the sound by a soft strike. In the following example, B will sound but A and C will not sound.

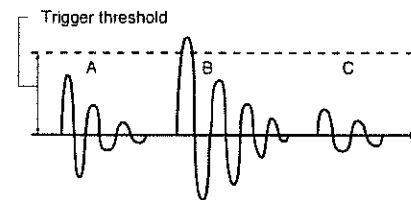

The factory setting is "2."

**Range: 1–4**

A setting of "1" is minimum, and "4" is maximum.

## Trigger Sensitivity (Hand/Stick)

This adjusts the sensitivity of the pads. "Hand" is the sensitivity that pertains to the times the pads are struck by hand, while "Stick" is the sensitivity used when striking the pads with sticks.

The factory setting is "2."

**Range: 1–4**

A setting of "1" produces low sensitivity, and "4" produces high sensitivity.



The [SENS] switch located on the rear panel of the SPD-6 selects the sensitivity specified for Hand or Stick.

# Features Using MIDI

## Connecting the SPD-6 to an External MIDI Sound Module

If you want to use the SPD-6 to sound an external MIDI sound module, use a MIDI cable to make connections.

1. Before making connections, turn off the power of all devices.



To prevent malfunction and/or damage to speakers or other devices, always turn down the volume, and turn off the power on all devices before making any connections.

2. Use the included MIDI cable to connect the MIDI OUT connector on the rear panel of the SPD-6 to the MIDI IN connector of your MIDI sound module.

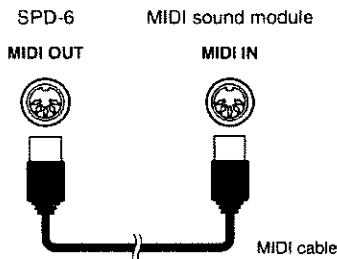

3. Switch on the power to the SPD-6 and the connected MIDI sound module.



If your MIDI sound module has a "Computer switch," set the computer switch to "MIDI" before turning on the power.

4. While playing the SPD-6, adjust the volume of the MIDI sound module.
5. You should also set the MIDI settings as needed.

## Other Ways to Use the SPD-6

Here are some ways in which the SPD-6 can be used together with other MIDI devices.



The MIDI channel on which the SPD-6 transmits music data is fixed at channel 10.



Refer to the owner's manual of your equipment for details on sound module settings.

## Using the SPD-6 With an Electronic Drum Set

You can use the SPD-6 in conjunction with an electronic drum set as supplementary pads. For example you can connect the SPD-6 to the sound module of your electronic drums, which allows you to play different sounds that are not assigned to the pads of your electronic drum set. This is an ideal way to expand the choice of sounds you have at one time.

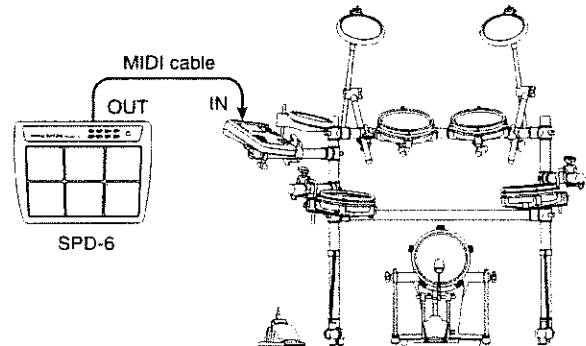

## Striking the SPD-6 to Play a Sound Module

By specifying the Program Change and Bank Select message transmitted by the SPD-6, you can play various drum sets on your sound module.

You can also set the MIDI reception channel of your sound module to channel 10, and use the SPD-6 to play different sounds and/or melodies.

Use a MIDI cable to connect the MIDI OUT connector of the SPD-6 to the MIDI IN connector of your sound module.

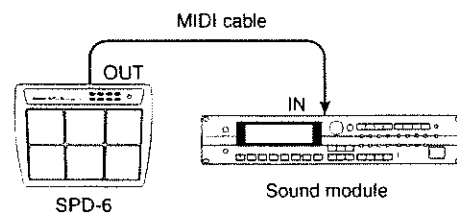

## Play Ensembles with a Roland Digital Piano or Organ

You can use the SPD-6 to play a drum, percussion or sound effect sets on your electronic piano.

Try playing along with someone playing the piano or organ.



If your electronic piano has a "MIDI ensemble function," make settings for connecting a percussion pad.

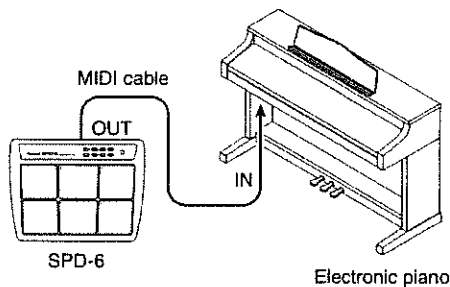

## How the Sounds Are Produced

When you use the SPD-6 to play a drum set of an external MIDI sound module, the sounds are produced as described below.

### Select a Patch

When you select a SPD-6 patch, commands (Program Change and Bank Select messages) are sent from the MIDI OUT connector to the external MIDI sound module, telling it to switch to the corresponding drum set.

The external MIDI sound module receives this command via its MIDI IN connector, and changes the drum set that it will play.

### Play the Pads or Press a Pedal to Play

When you play a pad or press a pedal on the SPD-6, a command (note-on message) is sent from its MIDI OUT connector to the external MIDI sound module, telling it to play the corresponding sound.

The external MIDI sound module receives this command via its MIDI IN connector, and plays the corresponding sound.

## Creating Your Own Patch

There are 16 patches that you can use to change the drum sets/instruments in the external MIDI sound module on the SPD-6 (User Group).

After you have become familiar with the SPD-6, try editing these settings to create your own patches. Listen to the percussion instrument sounds and choose your favorite sounds to create your own patches.

First, select the drum set or SFX set that you wish to play. Next, select the sounds that will be heard when you strike each pad.



If you are unable to make the changes you want, you can return the SPD-6 to the original factory settings. Refer to "Restoring the Factory Settings (Factory Reset)" (p. 33).

### Make Settings for Each Patch

You can set Program Change and Bank Select that each patch transmit.

#### Specifying the Combination of Program Change and Bank Select to be Transmitted

Select the drum set or SFX set of the General MIDI 2 or GS sound module that you want to play from the SPD-6.

1. Hold down [OTHERS/U4] and press [POWER] to turn on the power of the SPD-6. (User Group)
2. Press and hold down the two buttons of the user patch that you wish to edit, and release them when [OTHERS/U4], [1], [2] and [3] begin to blink.



To cancel the operation, press [OTHERS/U4] (flashing). The user patch you selected in step 2 can now be played.

3. Press [3].  
[OTHERS/U4] flashes, and the buttons light according to the drum set setting.
4. In the following table, find the drum set that you wish to use, and successively press the buttons listed beside it. Play the pads or press the pedals to hear the results of editing the drum set.

| Drum sets       | SPD-6 operation  | MSB                            | LSB | PC |
|-----------------|------------------|--------------------------------|-----|----|
| GS Standard Set | [DRUMS/U1] → [1] | 00                             | 00  | 1  |
| GS Room Set     | [DRUMS/U1] → [2] | 00                             | 00  | 9  |
| Power Set       | [DRUMS/U1] → [3] | 00                             | 00  | 17 |
| Electronic Set  | [DRUMS/U1] → [4] | 00                             | 00  | 25 |
| TR-808 Set      | [PERC/U2] → [1]  | 00                             | 00  | 26 |
| Jazz Set        | [PERC/U2] → [2]  | 00                             | 00  | 33 |
| GS Brush Set    | [PERC/U2] → [3]  | 00                             | 00  | 41 |
| Orchestral Set  | [PERC/U2] → [4]  | 00                             | 00  | 49 |
| SFX Set         | [SFX/U3] → [1]   | 00                             | 00  | 57 |
| Standard Set    | [SFX/U3] → [2]   | 00                             | 64  | 1  |
| OFF             | [SFX/U3] → [3]   | Not transmitted                |     |    |
| User Set        | [SFX/U3] → [4]   | Setting Desired Values (p. 29) |     |    |

\* MSB: Transmitted Bank Select MSB (controller number 0)  
 LSB: Transmitted Bank Select LSB (controller number 32)  
 PC: Transmitted Program Change (program number)



- The **OFF** setting prevents the drum set of the electronic piano from changing when you select a patch.
- Use a **User Set** when you wish to use a drum set that does not appear in the table. If you wish to use a user set, edit the user set as described in "Input the Program Change and Bank Select MSB/LSB" (p. 29). For a user set, different settings can be made for each user patch.



- If your electronic piano does not have a standard set ([SFX/U3]→[2]), there may be no sound if you select this set, or a different drum set may sound.
- For SFX set, there may be no sound when you strike the pad. To hear the sound, refer to "Changing the Transmitted Note Numbers" (p. 30) and set the note number.

5. Press [OTHERS/U4] (flashing) to save the settings.

After the buttons that you selected in step 4 flashes, you can perform using the edited settings.



Do not turn off the power after you press [OTHERS/U4] until after the button of the edited patch has lit.



#### Canceling changes BEFORE saving

- When you wish to play immediately  
 → Hold down [SFX/U3] and press [OTHERS/U4]. After the button corresponding to the value of the setting prior to editing is flashing, the patch you selected in step 2 can be played in its unedited state.
- When you wish to turn off the power  
 → Press [POWER] to turn off the power. When you hold down [OTHERS/U4] and turn on the power once again, and select the user patch, it can be played in its unedited state.

## Input the Program Change and Bank Select MSB/LSB

Use decimal notation to input the Program Change and Bank Select MSB/LSB that will be transmitted by the SPD-6 when you select the user patch.

You can make independent settings for each of the sixteen user patches.



- When you make this setting, the settings of "Specifying the Combination of Program Change and Bank Select to be Transmitted" (p. 28) will automatically become the user set.
- When making these settings, the Auto Power Off function is disabled.



For details on the Program Change and Bank Select, refer to the owner's manual of the device connected to the SPD-6.

1. Press [POWER] to turn off the power of the SPD-6.
2. Hold down the two buttons of the user patch that you wish to edit, and press the [POWER] to turn on the power.

The two buttons of the user patch to be edited flash.



To cancel the operation, press [OTHERS/U4]. The user patch you selected in step 2 can now be played.

3. Refer to the following table, and select the parameter that you wish to edit.

| Parameter         | SPD-6 operation                    |
|-------------------|------------------------------------|
| Program Change    | Hold down [PERC/U2] and press [1]. |
| Bank Select (MSB) | Hold down [PERC/U2] and press [2]. |
| Bank Select (LSB) | Hold down [PERC/U2] and press [3]. |

[OTHERS/U4] flashes, and [PERC/U2] lights.

4. Set the parameter that you selected in step 3.  
Use the patch select buttons and the pads to input the Program Change and Bank Select MSB/LSB values.

| Button/pad | Input value |
|------------|-------------|
| [1]        | 1           |
| [2]        | 2           |
| [3]        | 3           |
| [4]        | 4           |
| Pad 1      | 5           |
| Pad 2      | 6           |
| Pad 3      | 7           |
| Pad 4      | 8           |
| Pad 5      | 9           |
| Pad 6      | 0           |

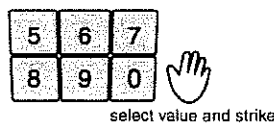
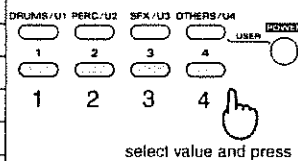

- **Example: Input "127"**  
Press [1] → [2], and strike the Pad 3.
- If you've input the wrong value, press [SFX/U3]. The value that was entered is canceled, and you're given a chance to input the value over again, from the beginning.



When striking a pad to input a value, accurately strike the center of the pad a little more strongly than usual. The setting cannot be made accurately by striking another pad or the case.

5. Press [OTHERS/U4] (flashing) to save the edited value.  
After [PERC/U2] flashes, you will once again be able to select a parameter (the state of step 2).  
At this time, the SPD-6 will transmit the Program Change and Bank Select MSB/LSB (all messages).



Do not turn off the power after pressing [OTHERS/U4] until after the buttons of the patch that you selected in step 2 have flashed.



### Canceling changes BEFORE saving

- If you wish to continue and set other parameters, hold down [SFX/U3] and press [OTHERS/U4]. After the button corresponding to the value of the setting prior to editing is flashing, you will be able to select the desired parameter. (The two buttons of the user patch that you selected in step 2 flash.)
- If you wish to turn off the power, press [POWER].

6. If you wish to edit other parameters, repeat steps 3–5.

7. When you have finished making all settings, press [OTHERS/U4].

Now you can play the user patch that you edited.

### Bank Select MSB/LSB (Controller Number 0/32)

Range: 0–127

### Program Change (Program Number)

Range: 1–128

# Make Settings for Each Pad

## Changing the Transmitted Note Numbers

You can change the sounds that are played by the six pads and two pedal switches (sold separately: DP-2).

### MEMO

You can select note numbers 20–99 of each drum set.

1. Hold down [OTHERS/U4] and press [POWER] to turn on the power of the SPD-6. (User Group)
2. Press and hold down the two buttons of the user patch that you wish to edit, and release them when [OTHERS/U4], [1], [2] and [3] begin to blink.



To cancel the operation, press [OTHERS/U4] (flashing). The user patch you selected in step 2 can now be played.

3. Press [2].  
[OTHERS/U4] flashes and one of the [1]–[4] buttons lights.
4. Strike a pad to select the pad whose sound you wish to change.  
Strike the center of the pad accurately, and slightly harder than usual.  
Only one of the buttons [1]–[4] will light according to the struck pad setting.
5. Make the setting for the pad that you selected in step 4.  
The note number will be sent when you operate the buttons, pads, or pedals.

| Operation        | Amount of change   | Range of available note numbers |
|------------------|--|---------------------------------|
| Press [1]        | Increases by one; after reaching the maximum value, returns to the minimum value | 20–39                           |
| Press [2]        |  | 40–59                           |
| Press [3]        |  | 60–79                           |
| Press [4]        |  | 80–99                           |
| Press [DRUMS/U1] | Decreases by one; stops at the minimum value                                     | 99–20                           |
| Press [PERC/U2]  | Increases by one; stops at the maximum value                                     | 20–99                           |

- The last-transmitted note number will be assigned to the pad or pedal switch.
- Continue holding down the button, and the value changes consecutively.
- If you press an unlit button [1]–[4], the minimum note number value that can be set for each button will be transmitted.
- If you hold down [PERC/U2] and press [DRUMS/U1], the

value will increase rapidly. If you hold down [DRUMS/U1] and press [PERC/U2], the value will decrease rapidly.



- When the note number 42 is assigned to a pad, you can control open (note number 46) and close (note number 42) of the hi-hat using a pedal switch.
- If you do not want sound to be heard when you press the pedal switch used to control the hi-hat, assign it to a note number that produces no sound.

### 6. Repeat steps 4 and 5.

To make settings for a pedal switch, press that pedal switch instead of striking a pad in each step.  
When you have finished making settings for all pads, proceed to step 7.

### 7. Press [OTHERS/U4] (flashing) to save the edited value.

After the button you selected flashes, you can perform using the edited settings.



Do not turn off the power after you press [OTHERS/U4] until the button of the edited patch has lit.



### Canceling changes BEFORE saving

- When you wish to play immediately  
→ Hold down [SFX/U3] and press [OTHERS/U4]. After the button corresponding to the value of the setting prior to editing is flashing, the patch you selected in step 2 can be played in its unedited state.
- When you wish to turn off the power  
→ Press [POWER] to turn off the power. When you hold down [OTHERS/U4] and turn on the power once again, and select the user patch, it can be played in its unedited state.

## Setting the Gate Time

For each pad or pedal, you can specify the length of time the note will “hold” during transmission from MIDI OUT.

General-purpose sound modules or samplers do receive the note-off messages that are transmitted and respond by turning off the sound.

This setting is necessary when playing SFX set or melodic sounds, loops in samplers etc.



When making these settings, the Auto Power Off function is disabled.

1. Press [POWER] to turn off the power of the SPD-6.
2. Hold down the two buttons of the user patch that you wish to edit, and press the [POWER] to turn on the power.  
The two buttons of the user patch to be edited flash.



To cancel the operation, press [OTHERS/U4]. The user patch you selected in step 2 can now be played.

3. Hold down [DRUMS/U1] and press [2].  
[OTHERS/U4] flashes, and [DRUMS/U1] and one of the [1]–[4] buttons light.
4. Strike a pad to select the pad whose sound you wish to change.  
Strike the center of the pad accurately, and slightly harder than usual.  
Only one of the buttons [1]–[4] will light according to the struck pad or pedal switch setting.
5. Refer to the following diagram, and press [1]–[4] to make settings.

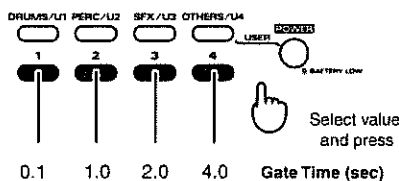

6. Repeat steps 4 and 5.  
To make settings for a pedal switch, press that pedal switch instead of striking a pad in each step.  
When you have finished making settings for all pads, proceed to step 7.

7. Press [OTHERS/U4] (flashing) to save the edited value.  
After the button you selected flashes, you will once again be able to select a parameter (the state of step 2).



Do not turn off the power after pressing [OTHERS/U4] until after the buttons of the patch that you selected in step 2 have flashed.



### Canceling changes BEFORE saving

- If you wish to continue and set other parameters, hold down [SFX/U3] and press [OTHERS/U4]. After the button corresponding to the value of the setting prior to editing is flashing, you will be able to select the desired parameter. (The two buttons of the user patch that you selected in step 2 flash.)
  - If you wish to turn off the power, press [POWER].
8. When you have finished making all settings, press [OTHERS/U4].  
Now you can play the user patch that you edited.

### Gate Time

The factory setting is “2.0 (sec.).”

Range: 0.1, 1.0, 2.0, 4.0 (sec.)

# Troubleshooting

If you have a problem, please check the following points.



Also check the owners manuals for other equipment you might be using. (MIDI or Audio)



You can restore the factory settings of the SPD-6. See "Restoring the Factory Settings (Factory Reset)" (p. 33).

## Problems Concerning the Entire SPD-6

### Power Does Not Turn On

- Are the batteries installed correctly? (p. 11)
- Battery power is weak?  
If battery power is low, the [POWER] button will blink.
- If you are using an AC adapter, is it connected properly? (p. 12)

### Sound is Not Heard

- Just after turning on the power, did you touch a pad before [DRUMS/U1] and [1] were lit?  
Turn the power on once more as explained p. 16.
- Volume level is adjusted correctly on the SPD-6 and your audio system (stereo system/digital piano etc.)? (p. 17)
- Are the SPD-6 and the other device(s) connected correctly? (p. 14)
- Is the power of all devices turned on? (p. 16)
- Did you specify internal sound "114 Off"?  
Specify "114 Off" when you do not want sound to be produced.  
Refer to p.46 and "Internal Sounds List" (p. 38), and select the desired sound.

### Volume is Insufficient When You Play the SPD-6/ The Sound is Not As You Expect

- Is the rear panel [SENS] switch set correctly? (p. 18)
- Are you accurately striking the center of the pad?  
Striking the case or the edge of a pad may cause the sound of another pad to be heard.
- Is the patch (sound set) selected correctly? (p. 18)
- Did you create your own patch?  
Refer to p. 22 and make sure that the patch and sound settings are correct.

### Buttons are Blinking

- Buttons will blink to inform you of an error.

## MIDI-Related Problems

### No Sound When You Play the SPD-6

- Did you create your own patch?  
There may be no sound if you specify a drum set or sound that does not exist on the device connected to the SPD-6. Refer to p. 26–p. 31, and to the owner's manual of the device connected to the SPD-6, and make sure that the patch and sound settings are correct.

## Error Message List

The SPD-6 will indicate an error message by blinking two or more of its buttons.

### The batteries have run down

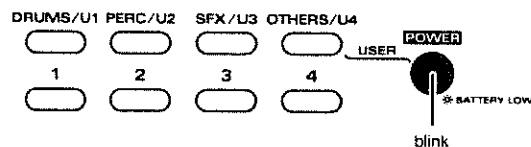

Turn off the power of the SPD-6 (p. 17), and replace the batteries (p. 11). Do not mix new batteries with partially used batteries, and do not mix batteries of differing types.

### It is possible that the internal memory of the SPD-6 has been corrupted

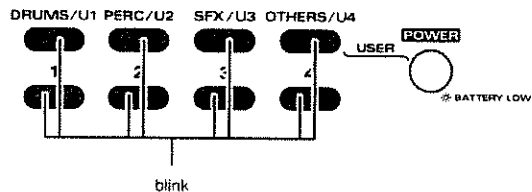

Press one of the Patch select buttons, and you can execute Factory Reset (p. 33). Press [OTHERS/U4] (flashing) to execute the Factory Reset.

If this does not resolve the problem, contact your dealer or a nearby Roland service center.



All settings you've made on the SPD-6 will be lost. All values will revert to what they were originally, when the unit was shipped from the factory.



# Restoring the Factory Settings (Factory Reset)

This procedure restores the original, factory-set values of the MIDI; internal sounds; sensitivity etc. settings stored in the SPD-6.

## NOTE

All settings you've made on the SPD-6 will be lost. All values will revert to what they were originally, when the unit was shipped from the factory. Before you begin the following procedure, make a note of any important settings, so that you will be able to reproduce them.

1

Hold down [DRUMS/U1], [PERC/U2], [SFX/U3], and [OTHERS/U4], and press [POWER] to turn on the power of the SPD-6.

[OTHERS/U4] flashes.

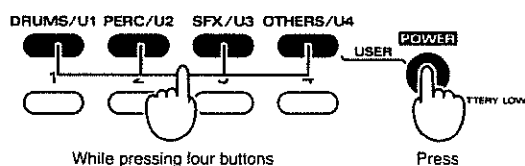

2

Press [OTHERS/U4] (flashes) to execute the operation.

[OTHERS/U4] lights.

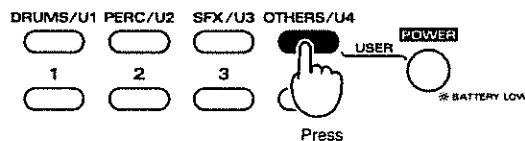

## NOTE

Press [OTHERS/U4], and then do not turn off the power of the SPD-6 until [DRUMS/U1] and [1] have lit.



### To cancel Factory Reset

- When you wish to play immediately  
→ Hold down [SFX/U3] and press [OTHERS/U4].
- When you wish to turn off the power  
→ Press [POWER] to turn off the power.

3

The SPD-6 will return to its factory settings, and can be played.

[DRUMS/U1] and [1] light.

# Patch List (Preset Group)

## When Playing the Internal Sounds of the SPD-6

### How to Use the Table

- The SPD-6 internal sound number is given within the parentheses ( ) next to the sound name.
- \*: When you have a pedal switch connected to the [PEDAL SW] 1 jack, you can switch the sound of the pad.  
When a pedal switch is not connected, the left sound will be heard.
- Order of sound names

Pad 1  
Pad 4  
Pedal Switch 1

Pad 2  
Pad 5

Pad 3  
Pad 6  
Pedal Switch 2

### DRUMS-1 (Drum Standard)

|  |  |  |
|--|--|--|
| Crash Cymbal 1 (54)<br>Kick (1)<br>Pedal Hi-Hat (49) | High Tom 1 (24)<br>Standard Snare (10) | Low Tom 1 (28)<br>Closed Hi-Hat (48) / Open Hi-Hat (50)*<br>Mix Kick (2) |
|--|--|--|

### DRUMS-2 (Drum Power)

|  |  |   |
|--|--|---|
| Crash Cymbal 1 (54)<br>MONDO Kick (5)<br>Pedal Hi-Hat (49) | Power Mid Tom 1 (31)<br>Dance Snare (11) | Power Low Tom 1 (37)<br>Closed Hi-Hat (48) / Open Hi-Hat (50)*<br>HipHop Kick (6) |
|--|--|---|

### DRUMS-3 (Drum Brush)

|   |   |  |
|---|---|--|
| Brush Roll Snare (21)<br>Jazz Kick 1 (3)<br>Pedal Hi-Hat (49) | Brush Swish Snare (22)<br>Brush Slap Snare (23) | Ride Cymbal1 (57)<br>Closed Hi-Hat (48) / Open Hi-Hat (50)*<br>Jazz Kick 2 (4) |
|---|---|--|

### DRUMS-4 (TR-808 (Analog))

|   |                                      |  |
|---|--------------------------------------|--|
| 808 Cymbal (59)<br>808 Kick 1 (7)<br>808 Closed Hi-Hat 1 (51) | 808 Mid Tom 1 (41)<br>808 Snare (16) | 808 Low Tom 1 (43)<br>808 Closed Hi-Hat 2 (52) / 808 Open Hi-Hat (53)*<br>808 Kick 2 (8) |
|---|--------------------------------------|--|

### PERC-1 (Conga and Bongo)

|  |   |  |
|--|---|--|
| Claves (67)<br>Open High Conga (63)<br>Shaker (71) | High Bongo (61)<br>Mute High Conga (64) | Low Bongo (62)<br>Low Conga (65)<br>Cowbell (66) |
|--|---|--|

### PERC-2 (Timbales)

|  |  |   |
|--|--|---|
| High Wood Block (83)<br>Low Timbale (74)<br>Maracas (70) | Low Wood Block (84)<br>High Timbale (73) | Splash Cymbal (56)<br>Cowbell (66)<br>Tambourine (72) |
|--|--|---|

### PERC-3 (Samba)

|  |                                   |   |
|--|-----------------------------------|---|
| Open Cuica (78)<br>Mute Cuica (79)<br>Whistle (82) | Low Agogo (77)<br>High Agogo (76) | Open Surdo (80)<br>Mute Surdo (81)<br>Shaker (71) |
|--|-----------------------------------|---|

### PERC-4 (Latin Toys)

|   |                                     |   |
|---|-------------------------------------|---|
| Vibra-Slap (75)<br>Open Triangle (86)<br>Maracas (70) | Short Guiro (69)<br>Long Guiro (68) | Tambourine (72)<br>Hand Clap (90)<br>Bell Tree (85) |
|---|-------------------------------------|---|

## Patch List (Preset Group)

### SFX-1 (Dance)

|   |                                  |  |
|---|----------------------------------|--|
| Slap (95)<br>Hand Clap (90)<br>String Slap (97) | Guitar Slide (96)<br>High Q (94) | Scratch Push (93)<br>Scratch Pull (92)<br>Scratch (91) |
|---|----------------------------------|--|

### SFX-2 (Human)

|   |                                |   |
|---|--------------------------------|---|
| Foot Step (106)<br>Door Creaking (104)<br>Thunder (111) | Heart Beat (107)<br>Door (105) | Screaming (108)<br>Punch (109)<br>Car-Crash (103) |
|---|--------------------------------|---|

### SFX-3 (Crash)

|   |                                  |  |
|---|----------------------------------|--|
| Car-Engine (101)<br>Telephone (98)<br>High Q (94) | Car-Stop (102)<br>Gun Shot (112) | Car-Crash (103)<br>Lasergun (113)<br>Slap (95) |
|---|----------------------------------|--|

### SFX-4 (Kids)

|   |                                     |   |
|---|-------------------------------------|---|
| Dog (99)<br>Thunder (111)<br>Hand Clap (90) | Kitty (100)<br>Metronome Click (89) | Laughing (110)<br>Metronome Bell (88)<br>Heart Beat (107) |
|---|-------------------------------------|---|

### OTHERS-1 (Drum with Pedal)

|   |   |  |
|---|---|--|
| Crash Cymbal 1 (54)<br>Standard Snare (10)<br>Pedal Hi-Hat (49) | High Tom 1 (24)<br>Closed Hi-Hat (48) / Open Hi-Hat (50)* | Mid Tom 1 (26)<br>Low Tom 1 (28)<br>Mix Kick (2) |
|---|---|--|

### OTHERS-2 (Drum Electronic)

|  |  |  |
|--|--|--|
| Crash Cymbal 1 (54)<br>808 Kick 1 (7)<br>Pedal Hi-Hat (49) | Electronic Mid Tom (46)<br>Electronic Snare 1 (17) | Electronic Low Tom (47)<br>Closed Hi-Hat (48) / Open Hi-Hat (50)*<br>Electronic Kick (9) |
|--|--|--|

### OTHERS-3 (Cymbal Set)

|   |   |   |
|---|---|---|
| Crash Cymbal 1 (54)<br>808 Cymbal (59)<br>Pedal Hi-Hat (49) | Crash Cymbal 2 (55)<br>Splash Cymbal (56) | Ride Cymbal 1 (57)<br>Ride Cymbal 2 (58)<br>808 Closed Hi-Hat1 (51) |
|---|---|---|

### OTHERS-4 (TR-808 (Analog) Tom Set)

|   |   |  |
|---|---|--|
| 808 High Tom 1 (39)<br>808 Mid Tom 2 (42)<br>808 Kick 1 (7) | 808 High Tom 2 (40)<br>808 Low Tom 1 (43) | 808 Mid Tom 1 (41)<br>808 Low Tom 2 (44)<br>808 Kick 2 (8) |
|---|---|--|

## Patch List (Preset Group)

# When Playing a Drum Set of an External MIDI Sound Module (Via MIDI)

When you connect the SPD-6 to a General MIDI 2/GS sound module, you can play with following instruments.

### How to Use the Table

- The name of the drum set used is listed beside the patch name.
- From the left, the parentheses ( ) beside the drum set name give the bank select MSB, bank select LSB, and program number.
- The note number transmitted by the SPD-6 is given within the parentheses ( ) next to the sound name.
- \*: When you have a pedal switch connected to the [PEDAL SW] 1 jack, you can switch the sound of the pad. When a pedal switch is not connected, the left sound will be heard.
- Order of sound names

| Pad 1<br>Pad 4<br>Pedal Switch 1                              | Pad 2<br>Pad 5                            | Pad 3<br>Pad 6<br>Pedal Switch 2   |
|---|---|--|
| <b>DRUMS-1 (Drum Standard)</b>                                | <b>GS Standard Set (00, 00, 1)</b>        |  |
| Crash Cymbal 1 (49)<br>Std Kick 1 (36)<br>Pedal Hi-Hat 1 (44) | High Tom 1 (50)<br>Snare Drum 1 (38)      | Low Tom 1 (43)<br>Closed Hi-hat 1 (42) / Open Hi-Hat 1 (46)*<br>Std Kick 2 (35)      |
| <b>DRUMS-2 (Drum Power)</b>                                   | <b>Power Set (00, 00, 17)</b>             |  |
| Crash Cymbal 1 (49)<br>MONDO Kick (36)<br>Pedal Hi-Hat (44)   | Room Mid Tom 1 (47)<br>Dance Snare (38)   | Room Low Tom 1 (43)<br>Closed Hi-Hat 1 (42) / Open Hi-Hat 1 (46)*<br>Std Kick 2 (35) |
| <b>DRUMS-3 (Drum Brush)</b>                                   | <b>GS Brush Set (00, 00, 41)</b>          |  |
| Brush Swirl (40)<br>Std Kick 1 (36)<br>Pedal Hi-Hat 1 (44)    | Brush Tap (38)<br>Brush Slap (39)         | Ride Cymbal1 (51)<br>Closed Hi-Hat 1 (42) / Open Hi-Hat 2 (46)*<br>Std Kick 2 (35)   |
| <b>DRUMS-4 (TR-808 (Analog))</b>                              | <b>TR-808 Set (00, 00, 26)</b>            |  |
| 808 Cymbal (49)<br>808 Bass Drum 1 (36)<br>808 CHH (44)       | 808 Mid Tom 1 (47)<br>808 Snare Drum (38) | 808 Low Tom 1 (43)<br>808 CHH (42) / 808 OHH (46)*<br>808 Bass Drum 1 (36)           |
| <b>PERC-1 (Conga and Bongo)</b>                               | <b>GS Standard Set (00, 00, 1)</b>        |  |
| Claves (75)<br>Open High Conga (63)<br>Shaker (82)            | High Bongo (60)<br>Mute High Conga (62)   | Low Bongo (61)<br>Low Conga (64)<br>Cowbell (56)                                     |
| <b>PERC-2 (Timbales)</b>                                      | <b>GS Standard Set (00, 00, 1)</b>        |  |
| High Wood Block (76)<br>Low Timbale (66)<br>Maracas (70)      | Low Wood Block (77)<br>High Timbale (65)  | Splash Cymbal (55)<br>Cowbell (56)<br>Tambourine (54)                                |
| <b>PERC-3 (Samba)</b>   | <b>GS Standard Set (00, 00, 1)</b>        |  |
| Open Cuica (79)<br>Mute Cuica (78)<br>Long Low Whistle (72)   | Low Agogo (68)<br>High Agogo (67)         | Open Surdo (87)<br>Mute Surdo (86)<br>Shaker (82)                                    |
| <b>PERC-4 (Latin Toys)</b>                                    | <b>GS Standard Set (00, 00, 1)</b>        |  |
| Vibra-Slap (58)<br>Open Triangle (81)<br>Maracas (70)         | Short Guiro (73)<br>Long Guiro (74)       | Tambourine (54)<br>Hand Clap (39)<br>Bell Tree (84)                                  |

## Patch List (Preset Group)

### SFX-1 (Dance)

### SFX Set (00, 00, 57)

Slap (40)  
Sticks (43)  
String slap of double bass (50)

Guitar Sliding Finger (47)  
High Q (39)

Scratch Push (41)  
Scratch Pull (42) / Metronome Bell (46)\*  
Scratch (61)

### SFX-2 (Human)

### SFX Set (00, 00, 57)

Footsteps 1 (56)  
Door Creaking (59)  
Thunder (80)

Heart Beat (55)  
Door (60)

Screaming (53)  
Punch (54)  
Car-Crash (66)

### SFX-3 (Crash)

### SFX Set (00, 00, 57)

Car-Engine (63)  
Siren (67)  
High Q (39)

Car-Stop (64)  
Gun Shot (72)

Car-Crash (66)  
Lasergun (74)  
Slap (40)

### SFX-4 (Kids)

### SFX Set (00, 00, 57)

Dog (76)  
Thunder (80)  
Slap (40)

Cat (85)  
Metronome Click (45)

Laughing (52)  
Metronome Bell (46)  
Heart Beat (55)

### OTHERS-1 (Drum with Pedal)

### GS Standard Set (00, 00, 1)

Crash Cymbal 1 (49)  
Snare Drum 1 (38)  
Pedal Hi-Hat 1 (44)

High Tom 1 (50)  
Closed Hi-Hat 1 (42) / Open Hi-Hat 1 (46)\*

Mid Tom 1 (47)  
Low Tom 1 (43)  
Std Kick 2 (35)

### OTHERS-2 (Drum Electronic)

### Electronic Set (00, 00, 25)

Crash Cymbal 1 (49)  
Elec BD (36)  
Pedal Hi-Hat 1 (44)

Elec Mid Tom 1 (47)  
Elec SD (38)

Elec Low Tom 1 (43)  
Closed Hi-Hat 1 (42) / Open Hi-Hat 1 (46)\*  
Std Kick 2 (35)

### OTHERS-3 (Cymbal Set)

### GS Standard Set (00, 00, 1)

Crash Cymbal 1 (49)  
Chinese Cymbal (52)  
Pedal Hi-Hat 1 (44)

Crash Cymbal 2 (57)  
Splash Cymbal (55)

Ride Cymbal 1 (51)  
Ride Cymbal 2 (59)  
Ride Bell (53)

### OTHERS-4 (TR-808 (Analog) Tom Set) TR-808 Set (00, 00, 26)

808 High Tom 1 (50)  
808 Mid Tom 2 (45)  
Std Kick 2 (35)

808 High Tom 2 (48)  
808 Low Tom 1 (43)

808 Mid Tom 1 (47)  
808 Low Tom 2 (41)  
808 Bass Drum 1 (36)

# Internal Sounds List

## Kick

- 1 Kick
- 2 Mix Kick
- 3 Jazz Kick 1
- 4 Jazz Kick 2
- 5 MONDO Kick
- 6 HipHop Kick
- 7 808 Kick 1
- 8 808 Kick 2
- 9 Electronic Kick

## Snare

- 10 Standard Snare
- 11 Dance Snare
- 12 HipHop Snare 1
- 13 HipHop Snare 2
- 14 Dopin' Snare
- 15 Gated Snare
- 16 808 Snare
- 17 Electronic Snare 1
- 18 Electronic Snare 2
- 19 Cross Stick
- 20 Snare Roll
- 21 Brush Roll Snare
- 22 Brush Swish Snare
- 23 Brush Slap Snare

## Tom

- 24 High Tom 1
- 25 High Tom 2
- 26 Mid Tom 1
- 27 Mid Tom 2
- 28 Low Tom 1
- 29 Low Tom 2
- 30 Room High Tom
- 31 Room Mid Tom
- 32 Room Low Tom
- 33 Power High Tom 1
- 34 Power High Tom 2
- 35 Power Mid Tom 1
- 36 Power Mid Tom 2
- 37 Power Low Tom 1
- 38 Power Low Tom 2
- 39 808 High Tom 1
- 40 808 High Tom 2
- 41 808 Mid Tom 1
- 42 808 Mid Tom 2
- 43 808 Low Tom 1
- 44 808 Low Tom 2
- 45 Electronic High Tom
- 46 Electronic Mid Tom
- 47 Electronic Low Tom

## Hi-Hat

- 48 Closed Hi-Hat [EXC 1]
- 49 Pedal Hi-Hat [EXC 1]
- 50 Open Hi-Hat [EXC 1]
- 51 808 Closed Hi-Hat 1 [EXC 1]
- 52 808 Closed Hi-Hat 2 [EXC 1]
- 53 808 Open Hi-Hat [EXC 1]

## Cymbal

- 54 Crash Cymbal 1
- 55 Crash Cymbal 2
- 56 Splash Cymbal
- 57 Ride Cymbal 1
- 58 Ride Cymbal 2
- 59 808 Cymbal
- 60 Reverse Cymbal

## Percussion

- 61 High Bongo
- 62 Low Bongo
- 63 Open High Conga
- 64 Mute High Conga
- 65 Low Conga
- 66 Cowbell
- 67 Claves
- 68 Long Guiro [EXC 2]
- 69 Short Guiro [EXC 2]
- 70 Maracas
- 71 Shaker
- 72 Tambourine
- 73 High Timbale
- 74 Low Timbale
- 75 Vibra-Slap
- 76 High Agogo
- 77 Low Agogo
- 78 Open Cuica [EXC 3]
- 79 Mute Cuica [EXC 3]
- 80 Open Surdo [EXC 4]
- 81 Mute Surdo [EXC 4]
- 82 Whistle
- 83 High Wood Block
- 84 Low Wood Block
- 85 Bell Tree
- 86 Open Triangle [EXC 5]
- 87 Mute Triangle [EXC 5]
- 88 Metronome Bell
- 89 Metronome Click

## Dance

- 90 Hand Clap
- 91 Scratch
- 92 Scratch Pull [EXC 6]
- 93 Scratch Push [EXC 6]
- 94 High Q
- 95 Slap
- 96 Guitar Slide
- 97 String Slap

## SFX

- 98 Telephone
- 99 Dog
- 100 Kitty
- 101 Car-Engine
- 102 Car-Stop
- 103 Car-Crash
- 104 Door Creaking
- 105 Door
- 106 Foot Step
- 107 Heart Beat
- 108 Screaming
- 109 Punch
- 110 Laughing
- 111 Thunder
- 112 Gun Shot
- 113 Lasergun

## No Sound

- 114 Off

### MEMO

[EXC \*]: Sounds of the same number will not play simultaneously.

# About MIDI

**MIDI (Musical Instrument Digital Interface)** is a standard that allows performance data and other information to be exchanged among electronic musical instruments and computers. By using a MIDI cable to connect devices that have MIDI connectors, you can create an ensemble in which a single MIDI keyboard can play multiple instruments, or change settings automatically as the song progresses.

Detailed knowledge of MIDI is not necessary when you use a MIDI cable to connect the SPD-6 to a GM2/GS devices, or when playing the SPD-6's internal sounds.

## About MIDI OUT Connector



This connector is used to transmit MIDI messages to an external MIDI device. This connector transmits messages that select drum sets on the device connected to the SPD-6's MIDI OUT connector, and messages that indicate pad strikes.



The MIDI channel on which the SPD-6 transmits music data is fixed at channel 10.

## About General MIDI/ General MIDI 2/GS

The SPD-6 is designed to be easily used in conjunction with a GM2/GS-compatible device.

### GM/General MIDI ( )

General MIDI is a set of recommendations which seeks to provide a way to go beyond the limitations of proprietary designs, and standardize the MIDI capabilities of sound generating devices. Sound generating devices and music files that meet the General MIDI standard bear the General MIDI logo (  ). Music files bearing the General MIDI logo can be played back using any General MIDI sound generating unit to produce essentially the same musical performance.

### GM2/General MIDI 2 ( )

The upwardly compatible General MIDI 2 (  ) recommendations pick up where the original General MIDI left off, offering enhanced expressive capabilities, and even greater compatibility. Issues that were not covered by the original General MIDI recommendations, such as how sounds are to be edited, and how effects should be handled, have now been precisely defined. Moreover, the available sounds have been expanded. General MIDI 2 compliant sound generators are capable of reliably playing back music files that carry either the General MIDI or General MIDI 2 logo. In some cases, the conventional form of General MIDI, which does not include the new enhancements, is referred to as "General MIDI 1" as a way of distinguishing it from General MIDI 2.

### GS Format ( )

The GS Format (  ) is Roland's set of specifications for standardizing the performance of sound generating devices. In addition to including support for everything defined by the General MIDI, the highly compatible GS Format additionally offers an expanded number of sounds, provides for the editing of sounds, and spells out many details for a wide range of extra features, including effects such as reverb and chorus. Designed with the future in mind, the GS Format can readily include new sounds and support new hardware features when they arrive.

# MIDI Implementation

Model SPD-6  
Version 1.00  
October.18.2000

## Transmit data

### ■Channel Voice Messages

#### ●Note off

Status            2nd byte            3rd byte  
8nH                kkH                vvH  
n = MIDI channel number:            9H (ch.10)  
kk = note number:                    14H - 63H (20 - 99)  
vv = note off velocity:                40H (64)

- \* Transmitted after the Gate Time specified for the pad.
- \* Transmitted as the note number specified for the pad.

#### ●Note on

Status            2nd byte            3rd byte  
9nH                kkH                vvH  
n = MIDI channel number:            9H (ch.10)  
kk = note number:                    14H - 63H (20 - 99)  
vv = note on velocity:                01H - 7FH (1 - 127)

- \* Note On message is transmitted when you strike the pad.
- \* Transmitted as the note number specified for the pad.

#### ●Control Change

##### ○Bank Select (Controller number 0, 32)

Status            2nd byte            3rd byte  
BnH                00H                mmH  
BnH                20H                llH  
n = MIDI channel number:            9H (ch.10)

mm = Bank number MSB.

ll = Bank number LSB.

mm, ll = Bank number:                00 00H - 7F 7FH (bank.1 - bank.16384)

- \* When a patch is selected, the bank select corresponding to the Drum Set number for the patch will be transmitted.
- \* The bank select messages corresponding to the Drum Set number are as follows.

| Drum Set No.      | Bank Select |     | Program No.  |
|-------------------|-------------|-----|--------------|
|                   | MSB         | LSB |              |
| 1:GS Standard Set | 00H         | 00H | 1(00H)       |
| 2:GS Room Set     | 00H         | 00H | 9(08H)       |
| 3:Power Set       | 00H         | 00H | 17(10H)      |
| 4:Electronic Set  | 00H         | 00H | 25(18H)      |
| 5:TR-808 Set      | 00H         | 00H | 26(19H)      |
| 6:Jazz Set        | 00H         | 00H | 33(20H)      |
| 7:GS Brush Set    | 00H         | 00H | 41(28H)      |
| 8:Orchestra Set   | 00H         | 00H | 49(30H)      |
| 9:SFZ Set         | 00H         | 00H | 57(38H)      |
| 10:Standard Set   | 00H         | 40H | 1(00H)       |
| 11:OFF            | ---         | --- | ----- *1     |
| 12:USER SET       | mmH         | llH | pp        *2 |

- \* 1: Not transmitted.
- \* 2: Transmit the values of the Bank Select MSB, Bank Select LSB, and Program Number parameter settings of the patch.
- \* The bank select and program number of each patch are as follows.

| Group     | Patch No. | Bank Select MSB | Bank Select LSB | Program No. | Drum Set No.      |
|-----------|-----------|-----------------|-----------------|-------------|-------------------|
| DRUMS/U1  | 1         | 00H             | 00H             | 1(00H)      | 1:GS Standard Set |
|           | 2         | 00H             | 00H             | 17(10H)     | 3:Power Set       |
|           | 3         | 00H             | 00H             | 41(28H)     | 7:GS Brush Set    |
|           | 4         | 00H             | 00H             | 26(19H)     | 5:TR-808 Set      |
| PERC/U2   | 1         | 00H             | 00H             | 1(00H)      | 1:GS Standard Set |
|           | 2         | 00H             | 00H             | 1(00H)      | 1:GS Standard Set |
|           | 3         | 00H             | 00H             | 1(00H)      | 1:GS Standard Set |
|           | 4         | 00H             | 00H             | 1(00H)      | 1:GS Standard Set |
| SFZ/U3    | 1         | 00H             | 00H             | 57(38H)     | 9:SFZ Set         |
|           | 2         | 00H             | 00H             | 57(38H)     | 9:SFZ Set         |
|           | 3         | 00H             | 00H             | 57(38H)     | 9:SFZ Set         |
|           | 4         | 00H             | 00H             | 57(38H)     | 9:SFZ Set         |
| OTHERS/U4 | 1         | 00H             | 00H             | 1(00H)      | 1:GS Standard Set |
|           | 2         | 00H             | 00H             | 25(18H)     | 4:Electronic Set  |
|           | 3         | 00H             | 00H             | 1(00H)      | 1:GS Standard Set |
|           | 4         | 00H             | 00H             | 26(19H)     | 5:TR-808 Set      |

#### ●Program Change

Status            2nd byte  
CnH                ppH  
n = MIDI channel number:            9H (ch.10)  
pp = Program number:                00H - 7FH (prog.1 - prog.128)

- \* When a patch is selected, the program number for the Drum Set assigned to the patch will be transmitted.

### ■System Realtime Messages

#### ●Active Sensing

Status  
FEH

- \* This will be transmitted constantly at intervals of approximately 200ms.



**MIDI Implementation**

PERCUSSION PAD  
Model SPD-6

Date : Oct. 18, 2000  
Version : 1.00

## MIDI Implementation Chart

| Function...   | Transmitted   | Recognized                 | Remarks           |
|---|---|----------------------------|-------------------|
| Basic Channel<br>Default Changed  | 10<br>X   | X<br>X                     |                   |
| Mode<br>Default Messages Altered  | Mode 3<br>X<br>*****  | X<br>X                     |                   |
| Note Number : True Voice  | 20-99<br>*****  | X<br>X                     |                   |
| Velocity<br>Note On<br>Note Off   | <input type="radio"/> 99H, v=1-127<br><input type="radio"/> 89H, v=64 | X<br>X                     |                   |
| After Touch<br>Key's<br>Channel's   | X<br>X  | X<br>X                     |                   |
| Pitch Bend  | X   | X                          |                   |
| Control Change<br><br>0, 32   | <input type="radio"/>   | X                          | Bank select       |
| Program Change : True Number  | <input type="radio"/><br>0-127  | X<br>X                     | Program No. 1-128 |
| System Exclusive  | X   | X                          |                   |
| System Common<br>: Song Position<br>: Song Select<br>: Tune Request   | X<br>X<br>X   | X<br>X<br>X                |                   |
| System Real Time<br>: Clock<br>: Commands   | X<br>X  | X<br>X                     |                   |
| Aux Messages<br>: All Sound Off<br>: Reset All Controllers<br>: Local On/Off<br>: All Notes Off<br>: Active Sensing<br>: System Reset | X<br>X<br>X<br>X<br><input type="radio"/><br>X                        | X<br>X<br>X<br>X<br>X<br>X |                   |
| Notes   |   |                            |                   |

Mode 1 : OMNI ON, POLY  
Mode 3 : OMNI OFF, POLY

Mode 2 : OMNI ON, MONO  
Mode 4 : OMNI OFF, MONO

: Yes  
 : No

# Specifications

## SPD-6: Percussion Pad

### Number of Pads

6 (velocity sensitive)

### MIDI Control

MIDI Channel: 10 (Fixed)

Note Number: 20-99

Bank Select MSB (CC0): 0-127

Bank Select LSB (CC32): 0-127

Program Change: 1-128

### Maximum Polyphony

4 voices

### Internal Sounds

113

### Patches

Preset patches: 16

User patches: 16

### Panel Control

Volume knob: 1

Sensitivity select switch: 1

Patch select buttons: 8

Power button: 1

### Connectors

Output jacks: 1 (PHONES), 2 (MONO)

MIDI OUT connector

Pedal switch jacks: 1, 2

AC adaptor jack

### Power Supply

DC 9 V: Dry battery (R6 (AA) type x 6) or AC adaptor



Expected battery life under continuous use:

Carbon: 8 hours

Alkaline: 20 hours

*These figures will vary depending on the actual conditions of use.*

### Current Draw

100 mA

### Dimensions

318 (W) x 241 (D) x 67 (H) mm

12-9/16 x 9-1/2 x 2-11/16 inches

### Weight

1.6 kg (including batteries)

3 lbs 9 oz

### Accessories

MIDI cable

Dry battery (R6 (AA) type) x 6

Stand holder mounting screw (M5 x 20) x 4

*\* Attached to the bottom panel*

Owner's Manual

### Options

AC adaptor (BOSS PSA series)

Pedal Switch (DP-2)

Foot Switch (BOSS FS-5U)

Pad Stand (PDS-15)

All Purpose Clamp (APC-33)



In the interest of product improvement, the specifications and/or appearance of this unit are subject to change without prior notice.

# Operation List

## Power-on Functions

| Operations when the power is turned on | Patch        | Auto Power Off |
|--|--------------|----------------|
|  | Preset Group | ○              |
|  | User Group   | ○              |
|  | Preset Group | X              |
|  | User Group   | X              |

## Edit Functions

### 1. Turn on the power.

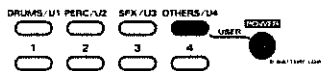

### 2. Hold down the two buttons of the user patch.

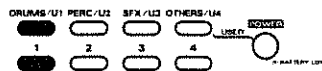

### 3. Select the parameter.

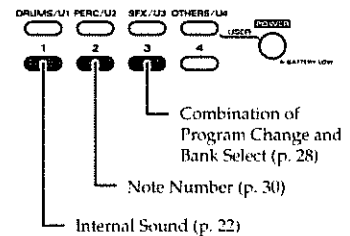

### 1. Hold down two buttons of the user patch, and press [POWER].

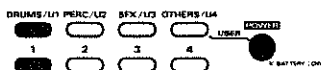

### 2. Select the parameter.

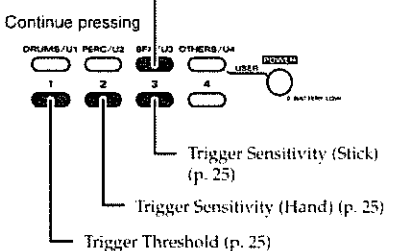
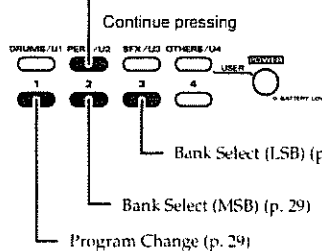
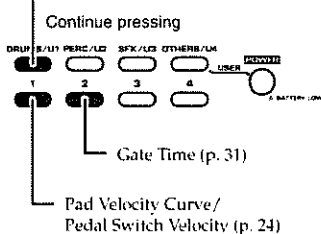
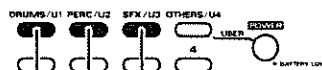

# Blank Chart

| Instrument No. | Note No. | Velocity Curve/<br>Velocity | Gate Time | Drum Set No. | User Set           |                    |
|----------------|----------|-----------------------------|-----------|--------------|--------------------|--------------------|
|                |          |                             |           |              | Bank Select<br>MSB | Bank Select<br>LSB |
| U2-1           | Pad 1    |                             |           |              |                    |                    |
|                | Pad 2    |                             |           |              |                    |                    |
|                | Pad 3    |                             |           |              |                    |                    |
|                | Pad 4    |                             |           |              |                    |                    |
|                | Pad 5    |                             |           |              |                    |                    |
|                | Pad 6    |                             |           |              |                    |                    |
| U2-2           | Pedal 1  |                             |           |              |                    |                    |
|                | Pedal 2  |                             |           |              |                    |                    |
|                | Pad 1    |                             |           |              |                    |                    |
|                | Pad 2    |                             |           |              |                    |                    |
|                | Pad 3    |                             |           |              |                    |                    |
|                | Pad 4    |                             |           |              |                    |                    |
| U2-3           | Pad 5    |                             |           |              |                    |                    |
|                | Pad 6    |                             |           |              |                    |                    |
|                | Pedal 1  |                             |           |              |                    |                    |
|                | Pedal 2  |                             |           |              |                    |                    |
|                | Pad 1    |                             |           |              |                    |                    |
|                | Pad 2    |                             |           |              |                    |                    |
| U2-4           | Pad 3    |                             |           |              |                    |                    |
|                | Pad 4    |                             |           |              |                    |                    |
|                | Pad 5    |                             |           |              |                    |                    |
|                | Pad 6    |                             |           |              |                    |                    |
|                | Pedal 1  |                             |           |              |                    |                    |
|                | Pedal 2  |                             |           |              |                    |                    |

| Instrument No. | Note No. | Velocity Curve/<br>Velocity | Gate Time | Drum Set No. | User Set           |                    |
|----------------|----------|-----------------------------|-----------|--------------|--------------------|--------------------|
|                |          |                             |           |              | Bank Select<br>MSB | Bank Select<br>LSB |
| U1-1           | Pad 1    |                             |           |              |                    |                    |
|                | Pad 2    |                             |           |              |                    |                    |
|                | Pad 3    |                             |           |              |                    |                    |
|                | Pad 4    |                             |           |              |                    |                    |
|                | Pad 5    |                             |           |              |                    |                    |
|                | Pad 6    |                             |           |              |                    |                    |
| U1-2           | Pedal 1  |                             |           |              |                    |                    |
|                | Pedal 2  |                             |           |              |                    |                    |
|                | Pad 1    |                             |           |              |                    |                    |
|                | Pad 2    |                             |           |              |                    |                    |
|                | Pad 3    |                             |           |              |                    |                    |
|                | Pad 4    |                             |           |              |                    |                    |
| U1-3           | Pad 5    |                             |           |              |                    |                    |
|                | Pad 6    |                             |           |              |                    |                    |
|                | Pedal 1  |                             |           |              |                    |                    |
|                | Pedal 2  |                             |           |              |                    |                    |
|                | Pad 1    |                             |           |              |                    |                    |
|                | Pad 2    |                             |           |              |                    |                    |
| U1-4           | Pad 3    |                             |           |              |                    |                    |
|                | Pad 4    |                             |           |              |                    |                    |
|                | Pad 5    |                             |           |              |                    |                    |
|                | Pad 6    |                             |           |              |                    |                    |
|                | Pedal 1  |                             |           |              |                    |                    |
|                | Pedal 2  |                             |           |              |                    |                    |

|                   |                            |                             |
|-------------------|----------------------------|-----------------------------|
| Trigger Threshold | Trigger Sensitivity (Hand) | Trigger Sensitivity (Stick) |
|-------------------|----------------------------|-----------------------------|

| Instrument No. | Note No. | Velocity Curve/<br>Velocity | Gate Time | Drum Set No. | User Set           |     | Program Change |
|----------------|----------|-----------------------------|-----------|--------------|--------------------|-----|----------------|
|                |          |                             |           |              | Bank Select<br>MSB | LSB |                |
| U4-1           | Pad 1    |                             |           |              |                    |     |                |
|                | Pad 2    |                             |           |              |                    |     |                |
|                | Pad 3    |                             |           |              |                    |     |                |
|                | Pad 4    |                             |           |              |                    |     |                |
|                | Pad 5    |                             |           |              |                    |     |                |
|                | Pad 6    |                             |           |              |                    |     |                |
|                | Pedal 1  |                             |           |              |                    |     |                |
|                | Pedal 2  |                             |           |              |                    |     |                |
| U4-2           | Pad 1    |                             |           |              |                    |     |                |
|                | Pad 2    |                             |           |              |                    |     |                |
|                | Pad 3    |                             |           |              |                    |     |                |
|                | Pad 4    |                             |           |              |                    |     |                |
|                | Pad 5    |                             |           |              |                    |     |                |
|                | Pad 6    |                             |           |              |                    |     |                |
|                | Pedal 1  |                             |           |              |                    |     |                |
|                | Pedal 2  |                             |           |              |                    |     |                |
| U4-3           | Pad 1    |                             |           |              |                    |     |                |
|                | Pad 2    |                             |           |              |                    |     |                |
|                | Pad 3    |                             |           |              |                    |     |                |
|                | Pad 4    |                             |           |              |                    |     |                |
|                | Pad 5    |                             |           |              |                    |     |                |
|                | Pad 6    |                             |           |              |                    |     |                |
|                | Pedal 1  |                             |           |              |                    |     |                |
|                | Pedal 2  |                             |           |              |                    |     |                |
| U4-4           | Pad 1    |                             |           |              |                    |     |                |
|                | Pad 2    |                             |           |              |                    |     |                |
|                | Pad 3    |                             |           |              |                    |     |                |
|                | Pad 4    |                             |           |              |                    |     |                |
|                | Pad 5    |                             |           |              |                    |     |                |
|                | Pad 6    |                             |           |              |                    |     |                |
|                | Pedal 1  |                             |           |              |                    |     |                |
|                | Pedal 2  |                             |           |              |                    |     |                |

| Instrument No. | Note No. | Velocity Curve/<br>Velocity | Gate Time | Drum Set No. | User Set           |     | Program Change |
|----------------|----------|-----------------------------|-----------|--------------|--------------------|-----|----------------|
|                |          |                             |           |              | Bank Select<br>MSB | LSB |                |
| U3-1           | Pad 1    |                             |           |              |                    |     |                |
|                | Pad 2    |                             |           |              |                    |     |                |
|                | Pad 3    |                             |           |              |                    |     |                |
|                | Pad 4    |                             |           |              |                    |     |                |
|                | Pad 5    |                             |           |              |                    |     |                |
|                | Pad 6    |                             |           |              |                    |     |                |
|                | Pedal 1  |                             |           |              |                    |     |                |
|                | Pedal 2  |                             |           |              |                    |     |                |
| U3-2           | Pad 1    |                             |           |              |                    |     |                |
|                | Pad 2    |                             |           |              |                    |     |                |
|                | Pad 3    |                             |           |              |                    |     |                |
|                | Pad 4    |                             |           |              |                    |     |                |
|                | Pad 5    |                             |           |              |                    |     |                |
|                | Pad 6    |                             |           |              |                    |     |                |
|                | Pedal 1  |                             |           |              |                    |     |                |
|                | Pedal 2  |                             |           |              |                    |     |                |
| U3-3           | Pad 1    |                             |           |              |                    |     |                |
|                | Pad 2    |                             |           |              |                    |     |                |
|                | Pad 3    |                             |           |              |                    |     |                |
|                | Pad 4    |                             |           |              |                    |     |                |
|                | Pad 5    |                             |           |              |                    |     |                |
|                | Pad 6    |                             |           |              |                    |     |                |
|                | Pedal 1  |                             |           |              |                    |     |                |
|                | Pedal 2  |                             |           |              |                    |     |                |
| U3-4           | Pad 1    |                             |           |              |                    |     |                |
|                | Pad 2    |                             |           |              |                    |     |                |
|                | Pad 3    |                             |           |              |                    |     |                |
|                | Pad 4    |                             |           |              |                    |     |                |
|                | Pad 5    |                             |           |              |                    |     |                |
|                | Pad 6    |                             |           |              |                    |     |                |
|                | Pedal 1  |                             |           |              |                    |     |                |
|                | Pedal 2  |                             |           |              |                    |     |                |

# Index

|  |        |
|--|--------|
| <b>A</b>                               |        |
| AC adaptor                             |        |
| AC adaptor jack .....                  | 9      |
| Connection .....                       | 12     |
| Auto Power Off Function .....          | 12     |
| <b>B</b>                               |        |
| Bank select MSB/LSB .....              | 29     |
| Battery                                |        |
| Battery cover .....                    | 8      |
| Getting too low .....                  | 32     |
| Install .....                          | 11     |
| Blank chart .....                      | 44     |
| Bottom panel .....                     | 8      |
| <b>C</b>                               |        |
| Controller Numbers 0/32 .....          | 29     |
| <b>E</b>                               |        |
| Error message .....                    | 32     |
| <b>F</b>                               |        |
| Factory reset .....                    | 33     |
| Front panel .....                      | 8      |
| <b>G</b>                               |        |
| Gate time (duration) .....             | 31     |
| GM (General MIDI) .....                | 39     |
| GM2 (General MIDI 2) .....             | 39     |
| GS Format .....                        | 39     |
| <b>H</b>                               |        |
| Headphones .....                       | 14     |
| <b>I</b>                               |        |
| Internal sounds                        |        |
| Internal sounds list .....             | 38     |
| Selecting the internal sounds .....    | 22     |
| <b>M</b>                               |        |
| MicroSaver Security Slot .....         | 9      |
| MIDI .....                             | 39     |
| MIDI implementation .....              | 40     |
| MIDI OUT connector .....               | 9, 39  |
| <b>N</b>                               |        |
| Note number .....                      | 30     |
| <b>O</b>                               |        |
| OUTPUT 1(PHONES)/2(MONO) jacks .....   | 9      |
| <b>P</b>                               |        |
| Pad .....                              | 8      |
| Pad velocity curve .....               | 24     |
| Patch                                  |        |
| About the Patch Name .....             | 10     |
| Patch select buttons .....             | 8      |
| Selecting .....                        | 18     |
| What is a patch? .....                 | 10     |
| Patch list                             |        |
| Internal sounds .....                  | 34     |
| Via MIDI .....                         | 36     |
| Pedal switch                           |        |
| Connecting .....                       | 15     |
| PEDAL SW jacks .....                   | 9      |
| Using .....                            | 15     |
| Pedal switch velocity .....            | 24     |
| Power                                  |        |
| POWER button .....                     | 8      |
| Power off .....                        | 17     |
| Power on .....                         | 16     |
| Program change (program number) .....  | 27, 29 |
| <b>R</b>                               |        |
| Rear panel .....                       | 9      |
| Restoring the factory settings .....   | 33     |
| <b>S</b>                               |        |
| SENS select switch .....               | 9      |
| Stand                                  |        |
| Attaching .....                        | 13     |
| Stand holder mounting screw .....      | 8      |
| <b>T</b>                               |        |
| Trigger sensitivity (Hand/Stick) ..... | 25     |
| Trigger threshold .....                | 25     |
| <b>V</b>                               |        |
| VOLUME knob .....                      | 9      |



For EU Countries

This product complies with the requirements of European Directive 89/336/EEC.

For the USA

## FEDERAL COMMUNICATIONS COMMISSION RADIO FREQUENCY INTERFERENCE STATEMENT

This equipment has been tested and found to comply with the limits for a Class B digital device, pursuant to Part 15 of the FCC Rules. These limits are designed to provide reasonable protection against harmful interference in a residential installation. This equipment generates, uses, and can radiate radio frequency energy and, if not installed and used in accordance with the instructions, may cause harmful interference to radio communications. However, there is no guarantee that interference will not occur in a particular installation. If this equipment does cause harmful interference to radio or television reception, which can be determined by turning the equipment off and on, the user is encouraged to try to correct the interference by one or more of the following measures:

- Reorient or relocate the receiving antenna.
- Increase the separation between the equipment and receiver.
- Connect the equipment into an outlet on a circuit different from that to which the receiver is connected.
- Consult the dealer or an experienced radio/TV technician for help.

Unauthorized changes or modification to this system can void the users authority to operate this equipment.  
This equipment requires shielded interface cables in order to meet FCC class B Limit.

For Canada

### NOTICE

This Class B digital apparatus meets all requirements of the Canadian Interference-Causing Equipment Regulations.

### AVIS

Cet appareil numérique de la classe B respecte toutes les exigences du Règlement sur le matériel brouilleur du Canada.

## Information

When you need repair service, call your nearest Roland Service Center or authorized Roland distributor in your country as shown below.

### AFRICA

#### EGYPT

**Al Fanny Trading Office**  
P.O. Box 2904,  
El Horrieh Heliopols, Cairo,  
EGYPT  
TEL: (02) 4185531

#### REUNION

**Maison FO - YAM Marcel**  
25 Rue Jules Hermann,  
Chaudron - BP79 97 491  
Ste Clotilde Cedex,  
REUNION ISLAND  
TEL: 28 29 16

#### SOUTH AFRICA

**That Other Music Shop  
(PTY) Ltd.**  
11 Melle St., Braamfontein,  
Johannesburg  
Republic of SOUTH AFRICA

P.O. Box 32918, Braamfontein 2017  
Republic of SOUTH AFRICA  
TEL: (011) 403 4105

**Paul Bothner (PTY) Ltd.**  
17 Werdmuller Centre Claremont  
7700  
Republic of SOUTH AFRICA

P.O. Box 23032  
Claremont, Cape Town  
SOUTH AFRICA, 7735  
TEL: (021) 674 4030

### ASIA

#### CHINA

**Beijing Xinghai Musical  
Instruments Co., Ltd.**  
6 Huangmichang Chao Yang  
District, Beijing, CHINA  
TEL: (010) 6774 7491

#### HONG KONG

**Tom Lee Music Co., Ltd.  
Service Division**  
22-32 Pun Shan Street, Tsuen  
Wan, New Territories,  
HONG KONG  
TEL: 2415 0911

#### INDIA

**Rivera Digitec (India) Pvt. Ltd.**  
409, Nirman Kendra Mahalaxmi  
Flats Compound Off. Dr. Edwin  
Moses Road, Mumbai-400011,  
INDIA  
TEL: (022) 498 3079

#### INDONESIA

**PT Citra Inti Rama**  
Jl. Cideng Timur No. 151-150  
Jakarta Pusat  
INDONESIA  
TEL: (021) 6324170

#### KOREA

**Cosmos Corporation**  
1461-9, Seocho-Dong,  
Seocho Ku, Seoul, KOREA  
TEL: (02) 3486-8855

#### MALAYSIA

**Bentley Music SDN BHD**  
140 & 142, Jalan Bukit Bintang  
55100 Kuala Lumpur, MALAYSIA  
TEL: (03) 2443333

#### PHILIPPINES

**G.A. Yupangco & Co. Inc.**  
339 Gil J. Payat Avenue  
Makati, Metro Manila 1200,  
PHILIPPINES  
TEL: (02) 899 9801

#### SINGAPORE

**Swee Lee Company**  
150 Sims Drive,  
SINGAPORE 387381  
TEL: 748-1669

**CRISTOFORI MUSIC PTE  
LTD**  
Blk 3014, Bedok Industrial Park E,  
#02-2148, SINGAPORE 489980  
TEL: 243 9555

#### TAIWAN

**ROLAND TAIWAN  
ENTERPRISE CO., LTD.**  
Room 5, 9th No. 112 Chung Shan  
N. Road Sec. 2, Taipei, TAIWAN,  
R.O.C.  
TEL: (02) 2561 3339

#### THAILAND

**Theera Music Co., Ltd.**  
330 Verng Nakorn Kasem, Soi 2,  
Bangkok 10100, THAILAND  
TEL: (02) 2248821

#### VIETNAM

**Saigon Music**  
138 Tran Quang Khai St.,  
District 1  
Ho Chi Minh City  
VIETNAM  
TEL: (08) 844-4068

### AUSTRALIA/ NEW ZEALAND

#### AUSTRALIA

**Roland Corporation  
Australia Pty., Ltd.**  
38 Campbell Avenue  
Dee Why West, NSW 2099  
AUSTRALIA  
TEL: (02) 9982 8266

#### NEW ZEALAND

**Roland Corporation (NZ) Ltd.**  
97 Mt. Eden Road, Mt. Eden,  
Auckland 3, NEW ZEALAND  
TEL: (09) 3098 715

### CENTRAL/LATIN AMERICA

#### ARGENTINA

**Instrumentos Musicales S.A.**  
Florida 656 2nd Floor  
Office Number 206A  
Buenos Aires  
ARGENTINA, CP1005  
TEL: (54-11) 4- 393-6057

#### BRAZIL

**Roland Brasil Ltda.**  
R. Coronel Octaviano da Silveira  
203 05522-010  
Sao Paulo BRAZIL  
TEL: (011) 3743 9377

#### COSTA RICA

**JUAN Bansbach  
Instrumentos Musicales**  
Ave. 1, Calle 11, Apartado 10237,  
San Jose, COSTA RICA  
TEL: (506) 258-0211

#### CHILE

**Comercial Fancy S.A.**  
Avenida Rancagua #0330  
Providencia Santiago, CHILE  
TEL: 56-2-373-9100

#### EL SALVADOR

**OMNI MUSIC**  
75 Avenida Notre YY Alameda,  
Juan Pablo 2, No. 4010  
San Salvador, EL SALVADOR  
TEL: (503) 262-0788

#### MEXICO

**Casa Veerkamp, s.a. de c.v.**  
Av. Toluca No. 323, Col. Olivar  
de los Padres 01780 Mexico D.F.  
MEXICO  
TEL: (525) 668 04 80

**La Casa Wagner de  
Guadalajara s.a. de c.v.**  
Av. Corona No. 202 S.J.  
Guadalajara, Jalisco Mexico  
C.P. 44100 MEXICO  
TEL: (3) 613 1414

#### PANAMA

**SUPRO MUNDIAL, S.A.**  
Boulevard Andrews, Albrook,  
Panama City,  
REP. DE PANAMA  
TEL: (507) 315-0101

#### PARAGUAY

**Distribuidora De  
Instrumentos Musicales**  
J.E. Olear y ESQ. Manduvira  
Edificio, El Dorado Planta Baja  
Asuncion PARAGUAY  
TEL: 595-21-492147

#### PERU

**VIDEO Broadcast S.A.**  
Portinari 199 (ESQ. HALS),  
San Borja, Lima 41,  
REP. OF PERU  
TEL: 51-14-758226

#### URUGUAY

**Todo Musica S.A.**  
Cuareim 1844, Munlevideo,  
URUGUAY, CP11200  
TEL: 5982-924-2335

#### VENEZUELA

**Musiland Digital C.A.**  
Av. Francisco de Miranda,  
Centro Parque de Cristal, Nivel  
C2 Local 20 Caracas  
VENEZUELA  
TEL: (02) 285 9218

### EUROPE

#### AUSTRIA

**Roland Austria GES.M.B.H.**  
Siemensstrasse 4, P.O. Box 74,  
A-6063 RUM, AUSTRIA  
TEL: (0512) 26 44 260

#### BELGIUM/HOLLAND/ LUXEMBOURG

**Roland Benelux N. V.**  
Houtstraat 3, B-2260, Oevel  
(Westerlo) BELGIUM  
TEL: (014) 575811

#### DENMARK

**Roland Scandinavia A/S**  
Nordhavnsvej 7, Postbox 880,  
DK-2100 Copenhagen  
DENMARK  
TEL: (039)16 6200

#### FRANCE

**Roland France SA**  
4, Rue Paul Henri SPAAK,  
Parc de l'Esplanade, F 77 462 St.  
Thibault, Lagny Cedex FRANCE  
TEL: 01 600 73 500

#### FINLAND

**Roland Scandinavia As,  
Filial Finland**  
Lautasaarentie 54 B  
Fin-00201 Helsinki, FINLAND  
TEL: (9) 682 4020

#### GERMANY

**Roland Elektronische  
Musikinstrumente HmbH.**  
Oststrasse 96, 22844 Norderstedt,  
GERMANY  
TEL: (040) 52 60090

#### GREECE

**STOLLAS S.A.**  
Music Sound Light  
155, New National Road  
26422 Patras, GREECE  
TEL: 061-435400

#### HUNGARY

**Intermusica Ltd.**  
Warehouse Area "DEPO" Pf.83  
H-2046 Torokbalint, HUNGARY  
TEL: (23) 511011

#### IRELAND

**Roland Ireland**  
Audio House, Belmont Court,  
Donnybrook, Dublin 4  
Republic of IRELAND  
TEL: (01) 2603501

#### ITALY

**Roland Italy S. p. A.**  
Viale delle Industrie 8,  
20020 Arese, Milano, ITALY  
TEL: (02) 937-78300

#### NORWAY

**Roland Scandinavia Avd.  
Kontor Norge**  
Lilleakerveien 2 Postboks 95  
Lilleaker N-0216 Oslo  
NORWAY  
TEL: 273 0074

#### POLAND

**P. P. H. Brzostowicz**  
UL. Gibraltarska 4,  
PL-03664 Warszawa POLAND  
TEL: (022) 679 44 19

#### PORTUGAL

**Tecnologias Musica e Audio,  
Roland Portugal, S.A.**  
RUA DE SANTA CARARINA  
131/133, 4000-450 PORTO  
PORTUGAL  
TEL: (022) 208 4456

#### ROMANIA

**FBS LINES**  
Plata Libertatii 1,  
RD-4200 Clougheni  
TEL: (066) 164-609

#### RUSSIA

**Slami Music Company**  
Sadogava-Triumfalnaja st., 16  
103006 Moscow, RUSSIA  
TEL: 095 209 2193

#### SPAIN

**Roland Electronics  
de España, S. A.**  
Calle Bolivia 239, 08020  
Barcelona, SPAIN  
TEL: (93) 308 1000

#### SWEDEN

**Roland Scandinavia A/S  
SWEDISH SALES OFFICE**  
Danvik Center 28, 2 tr.  
S-131 30 Nacka SWEDEN  
TEL: (08) 702 0020

#### SWITZERLAND

**Roland (Switzerland) AG  
Musitronic AG**  
Gerberstrasse 5, Postfach,  
CH-4410 Liestal, SWITZERLAND  
TEL: (061) 921 1615

#### UKRAINE

**TIC-TAC**  
Mira Str. 19/108  
P.O. Box 180  
295400 Munkachevo, UKRAINE  
TEL: (03131) 414-40

#### UNITED KINGDOM

**Roland (U.K.) Ltd.**  
Atlantic Close, Swansea  
Enterprise Park, SWANSEA  
SA7 9FJ,  
UNITED KINGDOM  
TEL: (01792) 700139

### MIDDLE EAST

#### BAHRAIN

**Moon Stores**  
Bab Al Bahrain Road,  
P.O. Box 20077  
State of BAHRAIN  
TEL: 211 005

#### CYPRUS

**Radex Sound Equipment Ltd.**  
17 Diagonou St., P.O. Box 2046,  
Nicosia CYPRUS  
TEL: (02) 453 426

#### ISRAEL

**Halilit P. Greenspoon &  
Sons Ltd.**  
8 Retzif Haraliya Hashnya St.  
Tel-Aviv-Yafa ISRAEL  
TEL: (03) 6823666

#### JORDAN

**AMMAN Trading Agency**  
Prince Muhammed St. P.O. Box  
825 Amman 11118 JORDAN  
TEL: (06) 4641200

#### KUWAIT

**Easa Husain Al-Yousifi**  
Abdullah Salem Street,  
Safar KUWAIT  
TEL: 5719499

#### LEBANON

**A. Chahine & Fils**  
P.O. Box 16-5857 Gergi Zeidan St.  
Chahine Building, Achrafieh  
Beirut, LEBANON  
TEL: (01) 335799

#### QATAR

**Al Emadi Co. (Badie Studio  
& Stores)**  
P.O. Box 62,  
DOHA QATAR  
TEL: 4423-554

#### SAUDI ARABIA

**aDawlah Universal  
Electronics APL**  
Corniche Road, Aldersary Bldg.,  
1st Floor  
SAUDI ARABIA

P.O. Box 2154, Alkthobar 31952  
SAUDI ARABIA  
TEL: (03) 898 2081

#### SYRIA

**Technical Light & Sound  
Center**  
Khaled Ibn Al Walid St.  
P.O. Box 13520  
Damascus - SYRIA  
TEL: (011) 2235 384

#### TURKEY

**Barkat muzik aletleri ithalat  
ve ihracat Ltd Sti**  
Siraselviler cad. Guney is hani 84-  
86/6, Taksim, Istanbul, TURKEY  
TEL: (0212) 2499324

#### U.A.E.

**Zak Electronics & Musical  
Instruments Co. L.L.C.**  
Zabael Road, Al Shercoq Bldg.,  
No. 14, Grand Floor DUBAI  
U.A.E.  
TEL: (04) 3360715

### NORTH AMERICA

#### CANADA

**Roland Canada Music Ltd.  
(Head Office)**  
5480 Parkwood Way Richmond  
B. C., V6V 2M4 CANADA  
TEL: (0604) 270 6626

#### Roland Canada Music Ltd.

**(Toronto Office)**  
Unit 2, 109 Woodbine Downs  
Blvd, Etobicoke, ON  
M9W 6Y1 CANADA  
TEL: (0416) 213 9707

#### U. S. A.

**Roland Corporation U.S.**  
5100 S. Eastern Avenue  
Los Angeles, CA 90040-2938,  
U. S. A.  
TEL: (323) 890 3700

As of November 1, 2000 (Roland)





 Roland®

02562267

UPC

02562267



1898:

 Roland®