

Each Multi-Effects Parameters

The multi-effects feature 90 different kinds of effects. Some of the effects consist of two or more different effects connected in series or in parallel.

Parameters marked with a sharp “#” can be controlled using a specified controller (Two setting items will change simultaneously for “#1” and “#2”).

1: STEREO EQ	(p. 3)	46: REVERSE DELAY	(p. 52)
2: OVERDRIVE	(p. 4)	47: SHUFFLE DELAY	(p. 54)
3: DISTORTION	(p. 5)	48: 3D DELAY	(p. 56)
4: PHASER	(p. 6)	49: 3VOICE PITCH SHIFTER.....	(p. 58)
5: SPECTRUM	(p. 7)	50: LOFI COMPRESS	(p. 59)
6: ENHANCER.....	(p. 8)	51: LOFI NOISE.....	(p. 60)
7: AUTO WAH.....	(p. 9)	52: SPEAKER SIMULATOR.....	(p. 62)
8: ROTARY	(p. 10)	53: OVERDRIVE 2.....	(p. 63)
9: COMPRESSOR.....	(p. 11)	54: DISTORTION 2	(p. 64)
10: LIMITER.....	(p. 12)	55: STEREO COMPRESSOR.....	(p. 65)
11: HEXA-CHORUS.....	(p. 13)	56: STEREO LIMITER	(p. 66)
12: TREMOLO CHORUS.....	(p. 14)	57: GATE	(p. 67)
13: SPACE-D.....	(p. 15)	58: SLICER	(p. 68)
14: STEREO CHORUS.....	(p. 16)	59: ISOLATOR.....	(p. 69)
15: STEREO FLANGER.....	(p. 17)	60: 3D CHORUS.....	(p. 70)
16: STEP FLANGER	(p. 19)	61: 3D FLANGER.....	(p. 71)
17: STEREO DELAY	(p. 20)	62: TREMOLO	(p. 73)
18: MODULATION DELAY	(p. 22)	63: AUTO PAN.....	(p. 74)
19: TRIPLE TAP DELAY.....	(p. 24)	64: STEREO PHASER 2	(p. 75)
20: QUADRUPLE TAP DELAY.....	(p. 25)	65: STEREO AUTO WAH.....	(p. 77)
21: TIME CONTROL DELAY	(p. 27)	66: ST FORMANT FILTER	(p. 78)
22: 2VOICE PITCH SHIFTER	(p. 28)	67: MULTI TAP DELAY 2	(p. 79)
23: FBK PITCH SHIFTER.....	(p. 30)	68: REVERSE DELAY 2.....	(p. 80)
24: REVERB.....	(p. 31)	69: SHUFFLE DELAY 2.....	(p. 82)
25: GATED REVERB	(p. 32)	70: 3D DELAY 2	(p. 83)
26: OVERDRIVE -> CHORUS.....	(p. 33)	71: ROTARY 2	(p. 85)
27: OVERDRIVE -> FLANGER	(p. 34)	72: ROTARY MULTI	(p. 87)
28: OVERDRIVE -> DELAY	(p. 35)	73: KEYBOARD MULTI.....	(p. 89)
29: DISTORTION -> CHORUS.....	(p. 36)	74: RHODES MULTI	(p. 92)
30: DISTORTION -> FLANGER.....	(p. 36)	75: JD MULTI.....	(p. 94)
31: DISTORTION -> DELAY	(p. 36)	76: STEREO LOFI COMPRESS	(p. 96)
32: ENHANCER -> CHORUS.....	(p. 37)	77: STEREO LOFI NOISE	(p. 97)
33: ENHANCER -> FLANGER.....	(p. 38)	78: GUITAR AMP SIMULATOR.....	(p. 99)
34: ENHANCER -> DELAY	(p. 39)	79: STEREO OVERDRIVE	(p. 101)
35: CHORUS -> DELAY	(p. 40)	80: STEREO DISTORTION.....	(p. 102)
36: FLANGER -> DELAY	(p. 41)	81: GUITAR MULTI A	(p. 103)
37: CHORUS -> FLANGER.....	(p. 42)	82: GUITAR MULTI B.....	(p. 106)
38: CHORUS/DELAY.....	(p. 43)	83: GUITAR MULTI C	(p. 109)
39: FLANGER/DELAY.....	(p. 43)	84: CLEAN GUITAR MULTI A	(p. 112)
40: CHORUS/FLANGER	(p. 43)	85: CLEAN GUITAR MULTI B.....	(p. 114)
41: STEREO PHASER.....	(p. 44)	86: BASS MULTI	(p. 117)
42: KEYSYNC FLANGER.....	(p. 46)	87: ISOLATOR 2.....	(p. 120)
43: FORMANT FILTER.....	(p. 48)	88: STEREO SPECTRUM	(p. 122)
44: RING MODULATOR.....	(p. 49)	89: 3D AUTO SPIN	(p. 123)
45: MULTI TAP DELAY	(p. 50)	90: 3D MANUAL	(p. 124)

Modulation (Effects that modulate the sound)

- 4: PHASER
- 7: AUTO WAH
- 41: STEREO PHASER
- 42: KEYSYNC FLANGER
- 43: FORMANT FILTER
- 44: RING MODULATOR
- 64: STEREO PHASER 2
- 65: STEREO AUTO WAH
- 66: ST FORMANT FILTER

Delay (Effects that delay the sound)

- 17: STEREO DELAY
- 18: MODULATION DELAY
- 19: TRIPLE TAP DELAY
- 20: QUADRUPLE TAP DELAY
- 21: TIME CONTROL DELAY
- 22: 2VOICE PITCH SHIFTER
- 23: FBK PITCH SHIFTER
- 34: ENHANCER -> DELAY
- 45: MULTI TAP DELAY
- 46: REVERSE DELAY
- 47: SHUFFLE DELAY
- 48: 3D DELAY
- 49: 3VOICE PITCH SHIFTER
- 67: MULTI TAP DELAY 2
- 68: REVERSE DELAY 2
- 69: SHUFFLE DELAY 2
- 70: 3D DELAY 2

Keyboard (Effects useful for the keyboard)

- 08: ROTARY
- 71: ROTARY 2
- 72: ROTARY MULTI
- 73: KEYBOARD MULTI
- 74: RHODES MULTI
- 75: JD MULTI

LoFi

(Effects that intentionally degrades the sound quality)

- 50: LOFI COMPRESS
- 51: LOFI NOISE
- 76: STEREO LOFI COMPRESS
- 77: STEREO LOFI NOISE

Guitar and Bass

(Effects useful for the Guitar and Bass)

- 2: OVERDRIVE
- 3: DISTORTION
- 26: OVERDRIVE -> CHORUS
- 27: OVERDRIVE -> FLANGER
- 28: OVERDRIVE -> DELAY
- 29: DISTORTION -> CHORUS
- 30: DISTORTION -> FLANGER
- 31: DISTORTION -> DELAY
- 52: SPEAKER SIMULATOR

- 53: OVERDRIVE 2
- 54: DISTORTION 2
- 78: GUITAR AMP SIMULATOR
- 79: STEREO OVERDRIVE
- 80: STEREO DISTORTION
- 81: GUITAR MULTI A
- 82: GUITAR MULTI B
- 83: GUITAR MULTI C
- 84: CLEAN GUITAR MULTI A
- 85: CLEAN GUITAR MULTI B
- 86: BASS MULTI

Compressor (Effects in which the loudness becomes difficult to change)

- 9: COMPRESSOR
- 10: LIMITER
- 55: STEREO COMPRESSOR
- 56: STEREO LIMITER
- 57: GATE
- 58: SLICER

Chorus (Effects that broaden the sound)

- 11: HEXA-CHORUS
- 12: TREMOLO CHORUS
- 13: SPACE-D
- 14: STEREO CHORUS
- 15: STEREO FLANGER
- 16: STEP FLANGER
- 32: ENHANCER -> CHORUS
- 33: ENHANCER -> FLANGER
- 35: CHORUS -> DELAY
- 36: FLANGER -> DELAY
- 37: CHORUS -> FLANGER
- 38: CHORUS/DELAY
- 39: FLANGER/DELAY
- 40: CHORUS/FLANGER
- 60: 3D CHORUS
- 61: 3D FLANGER

Dimension

(Effects that control the location of the sound)

- 62: TREMOLO
- 63: AUTO PAN
- 89: 3D AUTO SPIN
- 90: 3D MANUAL

Filter (Effects that modify the sound character)

- 1: STEREO EQ
- 5: SPECTRUM
- 6: ENHANCER
- 59: ISOLATOR
- 87: ISOLATOR 2
- 88: STEREO SPECTRUM

Reverb (Effects that reverberate the sound)

- 24: REVERB
- 25: GATED REVERB

1: STEREO EQ (Stereo Equalizer)

This is a four-band stereo equalizer (low, mid x 2, high).

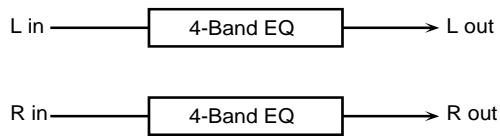

Freq/Gain

LowFreq (Low Frequency)

Select the frequency of the low range (200 Hz/400 Hz).

LowGain

Adjust the gain of the low frequency.

Mid1 Freq (Middle 1 Frequency)

Adjust the frequency of Middle 1 (mid range).

Mid1 Gain (Middle1 Gain)

Adjust the gain for the area specified by the Middle 1 Frequency and Q settings.

Mid2 Freq (Middle 2 Frequency)

Adjust the frequency of Middle 2 (mid range).

Mid2 Gain (Middle 2 Gain)

Adjust the gain for the area specified by the Middle 2 Frequency and Q settings.

High Freq (High Frequency)

Select the frequency of the high range (4000 Hz/8000 Hz).

High Gain

Adjust the gain of the high frequency.

Band Width

Mid1 Q (Middle 1 Q)

This parameter adjusts the width of the area around the Middle 1 Frequency that will be affected by the Gain setting. Higher values of Q will result in a narrower area being affected.

Mid2 Q (Middle 2 Q)

This parameter adjusts the width of the area around the Middle 2 Frequency that will be affected by the Gain setting. Higher values of Q will result in a narrower area being affected.

Output

Level (Output Level)

Adjust the output level.

2: OVERDRIVE

This effect creates a soft distortion similar to that produced by vacuum tube amplifiers.

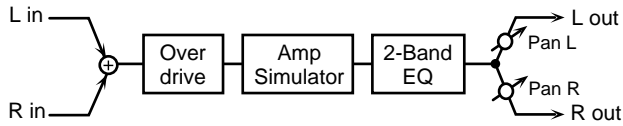

Overdrive

Drive

Adjust the degree of distortion. The volume will change together with the degree of distortion.

Amp Simulator

Type (Amp Simulator Type)

Select the type of guitar amp.

SMALL: small amp

BUILT-IN: single-unit type amp

2-STACK: large double stack amp

3-STACK: large triple stack amp

EQ Gain

Low (Low Gain)

Adjust the gain of the low frequency range.

High (High Gain)

Adjust the gain of the high frequency range.

Output

Level (Output Level)

Adjust the output level.

Pan (Output Pan)

Adjust the stereo location of the output sound. L64 is far left, 0 is center, and 63R is far right.

3: DISTORTION

This effect produces a more intense distortion than Overdrive.

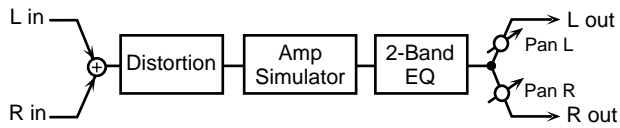

Distortion

Drive

Adjust the degree of distortion. The volume will change together with the degree of distortion.

Amp Simulator

Type (Amp Simulator Type)

Select the type of guitar amp.

SMALL: small amp

BUILT-IN: single-unit type amp

2-STACK: large double stack amp

3-STACK: large triple stack amp

EQ Gain

Low (Low Gain)

Adjust the gain of the low frequency range.

High (High Gain)

Adjust the gain of the high frequency range.

Output

Level (Output Level)

Adjust the output level.

Pan (Output Pan)

Adjust the stereo location of the output sound. L64 is far left, 0 is center, and 63R is far right.

4: PHASER

A phaser adds a phase-shifted sound to the original sound, producing a twisting modulation that creates spaciousness and depth.

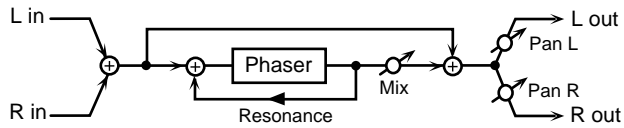

Phaser

Manual

Adjust the basic frequency from which the sound will be modulated.

Rate

Adjust the frequency (period) of modulation.

Depth

Adjust the depth of modulation.

Resonance

Adjust the amount of feedback for the phaser.

Mix Level

Adjust the ratio with which the phase-shifted sound is combined with the direct sound.

Output

Level (Output Level)

Adjust the output level.

Pan (Output Pan)

Adjust the stereo location of the output sound. L64 is far left, 0 is center, and 63R is far right.

5: SPECTRUM

Spectrum is a type of filter which modifies the timbre by boosting or cutting the level at specific frequencies. It is similar to an equalizer, but has 8 frequency points fixed at locations most suitable for adding character to the sound.

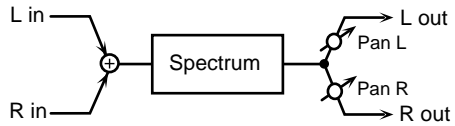

Gain

250Hz (Band 1 Gain)

Adjust the 250 Hz level.

500Hz (Band 2 Gain)

Adjust the 500 Hz level.

1000Hz (Band 3 Gain)

Adjust the 1000 Hz level.

1250Hz (Band 4 Gain)

Adjust the 1250 Hz level.

2000Hz (Band 5 Gain)

Adjust the 2000 Hz level.

3150Hz (Band 6 Gain)

Adjust the 3150 Hz level.

4000Hz (Band 7 Gain)

Adjust the 4000 Hz level.

8000Hz (Band 8 Gain)

Adjust the 8000 Hz level.

Band Width

Q

Simultaneously adjust the width of the adjusted areas for all the frequency bands.

Output

Level (Output Level)

Adjust the output level.

Pan (Output Pan)

Adjust the stereo location of the output sound. L64 is far left, 0 is center, and 63R is far right.

6: ENHANCER

The Enhancer controls the overtone structure of the high frequencies, adding sparkle and tightness to the sound.

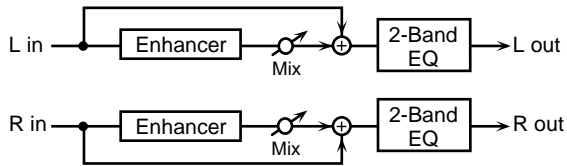

Enhancer

Sens (Sensitivity)

Adjust the sensitivity of the enhancer.

Mix Level

Adjust the ratio with which the overtones generated by the enhancer are combined with the direct sound.

EQ Gain

Low (Low Gain)

Adjust the gain of the low frequency range.

High (High Gain)

Adjust the gain of the high frequency range.

Output

Level (Output Level)

Adjust the output level.

7: AUTO WAH

The Auto Wah cyclically controls a filter to create cyclic change in timbre.

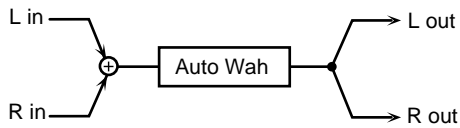

Auto Wah

Filter (Filter Type)

Select the type of filter.

LPF:The wah effect will be applied over a wide frequency range.

BPF:The wah effect will be applied over a narrow frequency range.

Sens

Adjust the sensitivity with which the filter is controlled.

Manual

Adjust the center frequency from which the effect is applied.

Peak

Adjust the amount of the wah effect that will occur in the area of the center frequency. Lower settings will cause the effect to be applied in a broad area around the center frequency. Higher settings will cause the effect to be applied in a more narrow range.

Rate (LFO Rate)#

Adjust the frequency of the modulation.

Depth (LFO Depth)

Adjust the depth of the modulation.

Output

Level (Output Level)

Adjust the output level.

8: ROTARY

The Rotary effect simulates the sound of the rotary speakers often used with the electric organs of the past. Since the movement of the high range and low range rotors can be set independently, the unique type of modulation characteristic of these speakers can be simulated quite closely. This effect is most suitable for electric organ Patches.

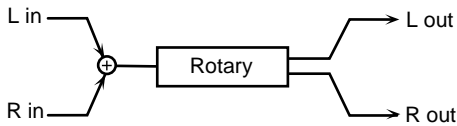

Rotary

Speed

Simultaneously switch the rotational speed of the low frequency rotor and high frequency rotor.

SLOW: Slow down the rotation to the specified speed (the Low Slow / Hi Slow values).

FAST: Speed up the rotation to the specified speed (the Low Fast / Hi Fast values).

Woofers

Slow Rate (Low Frequency Slow Rate)

Adjust the slow speed (SLOW) of the low frequency rotor.

Fast Rate (Low Frequency Fast Rate)

Adjust the fast speed (FAST) of the low frequency rotor.

Acceleration (Low Frequency Acceleration)

Adjust the time it takes the low frequency rotor to reach the newly selected speed when switching from fast to slow (or slow to fast) speed. Lower values will require longer times.

Level (Low Frequency Level)

Adjust the volume of the low frequency rotor.

Separation

Separation

Adjust the spatial dispersion of the sound.

Tweeter

Slow Rate (High Frequency Slow Rate)

Adjust the slow speed (SLOW) of the high frequency rotor.

Fast Rate (High Frequency Fast Rate)

Adjust the fast speed (FAST) of the high frequency rotor.

Acceleration (High Frequency Acceleration)

Adjust the time it takes the high frequency rotor to reach the newly selected speed when switching from fast to slow (or slow to fast) speed. Lower values will require longer times.

Level (High Frequency Level)

Adjust the volume of the high frequency rotor.

Output

Level (Output Level)

Adjust the output level.

9: COMPRESSOR

The Compressor flattens out high levels and boosts low levels, smoothing out unevenness in volume.

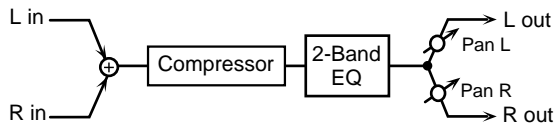

Compressor

Attack

Adjust the attack time of an input sound.

Sustain

Adjust the time over which low level sounds are boosted until they reach the specified volume.

Post Gain

Adjust the output gain.

EQ Gain

Low (LowGain)

Adjust the low frequency gain.

High (High Gain)

Adjust the high frequency gain.

Output

Level (Output Level)

Adjust the output level.

Pan (Output Pan)

Adjust the stereo location of the output sound. L64 is far left, 0 is center, and 63R is far right.

10: LIMITER

The Limiter compresses signals that exceed a specified volume level, preventing distortion from occurring.

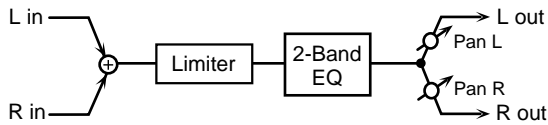

Limiter

Threshold (Threshold Level)

Adjust the volume at which compression will begin.

Ratio (Compression Ratio)

Adjust the compression ratio.

Release (Release Time)

Adjust the time from when the volume falls below the Threshold Level until compression is no longer applied.

Post Gain

Adjust the output gain.

EQ Gain

Low (LowGain)

Adjust the low frequency gain.

High (High Gain)

Adjust the high frequency gain.

Output

Level (Output Level)

Adjust the output level.

Pan (Output Pan)

Adjust the stereo location of the output sound. L64 is far left, 0 is center, and 63R is far right.

11: HEXA-CHORUS

Hexa-chorus uses a six-phase chorus (six layers of chorused sound) to give richness and spatial spread to the sound.

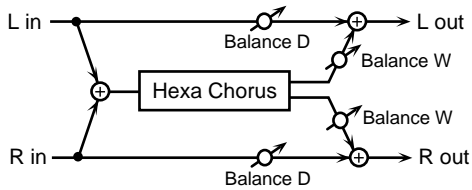

Hexa Chorus

Rate

Adjust the rate of modulation.

Depth

Adjust the depth of modulation.

Depth Dev (Depth Deviation)

Adjust the difference in modulation depth between each chorus sound.

Pre Delay (Pre Delay Time)

Adjust the time delay from when the direct sound begins until the chorus sound is heard.

Pre Delay Dev (Pre Delay Deviation)

Pre Delay determines the time from when the direct sound begins until the processed sound is heard. Pre Delay Deviation adjusts the differences in Pre Delay between each chorus sound.

Pan Dev (Pan Deviation)

Adjust the difference in stereo location between each chorus sound. With a setting of 0, all chorus sounds will be in the center. With a setting of 20, each chorus sound will be spaced at 60 degree intervals relative to the center.

Balance

Balance (Effect Balance)

Adjust the volume balance between the direct sound and the chorus sound. With a setting of D100:0W only the direct sound will be output, and with a setting of D0:100W only the chorus sound will be output.

Output

Level (Output Level)

Adjust the output level.

12: TREMOLO CHORUS

Tremolo Chorus is a chorus effect with added Tremolo (cyclic modulation of volume).

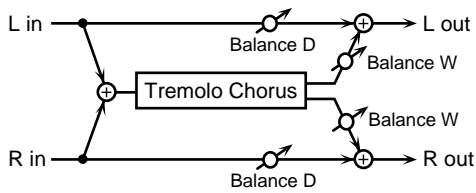

Chorus

Rate (Chorus Rate)

Adjust the modulation speed of the chorus effect.

Depth (Chorus Depth)

Adjust the modulation depth of the chorus effect.

Pre Delay (Pre Delay Time)

Adjust the time delay from when the direct sound begins until the chorus sound is heard.

Tremolo

Rate (Tremolo Rate)

Adjust the modulation speed of the tremolo effect.

Phase (Tremolo Phase)

Adjust the spread of the tremolo effect.

Separation (Tremolo Separation)

Adjust the spread of the tremolo effect.

Balance

Balance (Effect Balance)

Adjust the volume balance between the direct sound and the tremolo chorus sound. With a setting of D100:0W only the direct sound will be output, and with a setting of D0:100W only the tremolo chorus sound will be output.

Output

Level (Output Level)

Adjust the output level.

13: SPACE-D

Space-D is a multiple chorus that applies two-phase modulation in stereo. It gives no impression of modulation, but produces a transparent chorus effect.

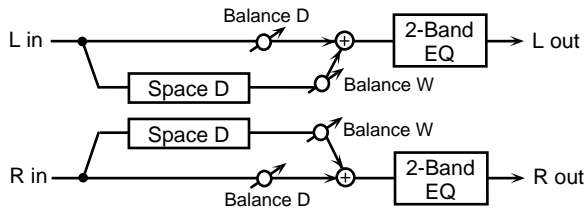

Chorus

Rate

Adjust the rate of modulation.

Depth

Adjust the depth of modulation.

Phase

Adjust the spatial spread of the sound.

Pre Delay (Pre Delay Time)

Adjust the time delay from when the direct sound begins until the processed sound is heard.

EQ Gain

Low (Low Gain)

Adjust the gain of the low frequency range.

High (High Gain)

Adjust the gain of the high frequency range.

Balance

Balance (Effect Balance)

Adjust the volume balance between the direct sound and the chorus sound. With a setting of D100:0W only the direct sound will be output, and with a setting of D0:100W only the chorus sound will be output.

Output

Level (Output Level)

Adjust the output level.

14: STEREO CHORUS

This is a stereo chorus. A filter is provided so that you can adjust the timbre of the chorus sound.

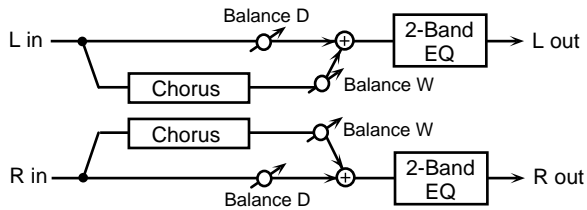

Chorus

Rate

Adjust the rate of modulation.

Depth

Adjust the depth of modulation.

Phase

Adjust the spatial spread of the sound.

Pre Delay (Pre Delay Time)

Adjust the time delay from when the direct sound begins until the processed sound is heard.

Filter

Type (Filter Type)

Select the type of filter.

OFF:a filter will not be used

LPF:cut the frequency range above the cutoff frequency

HPF:cut the frequency range below the cutoff frequency

Cutoff (Cutoff Frequency)

Adjust the basic frequency of the filter.

EQ Gain

Low (LowGain)

Adjust the gain of the low frequency range.

High (High Gain)

Adjust the gain of the high frequency range.

Balance

Balance (Effect Balance)

Adjust the volume balance between the direct sound and the chorus sound. With a setting of D100:0W only the direct sound will be output, and with a setting of D0:100W only the chorus sound will be output.

Output

Level (Output Level)

Adjust the output level.

15: STEREO FLANGER

This is a stereo flanger. (The LFO has the same phase for left and right.) It produces a metallic resonance that rises and falls like a jet airplane taking off or landing. A filter is provided so that you can adjust the timbre of the flanged sound.

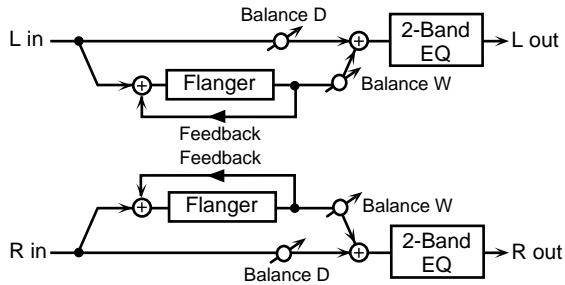

Flanger

Rate (LFO Rate)

Adjust the rate of modulation.

Depth (LFO Depth)

Adjust the depth of modulation.

Feedback (Feedback Level)

Adjust the amount (%) of the processed sound that is returned (fed back) into the input. Positive (+) settings will return the sound in phase, and negative (-) settings will return the sound in reverse phase.

Phase

Adjust the spatial spread of the sound.

Pre Delay (Pre Delay Time)

Adjust the time delay from when the direct sound begins until the flanger sound is heard.

Filter

Type

Select the type of filter.

OFF: a filter will not be used

LPF: cut the frequency range above the cutoff frequency

HPF: cut the frequency range below the cutoff frequency

Cutoff (Cutoff Frequency)

Adjust the basic frequency of the filter.

EQ Gain

Low (LowGain)

Adjust the gain of the low frequency range.

High (High Gain)

Adjust the gain of the high frequency range.

Balance

Balance (Effect Balance)

Adjust the volume balance between the direct sound and the flanger sound. With a setting of D100:0W only the direct sound will be output, and with a setting of D0:100W only the flanger sound will be output.

Output

Level (Output Level)

Adjust the output level.

16: STEP FLANGER

The Step Flanger effect is a flanger in which the flanger pitch changes in steps. The speed at which the pitch changes can also be specified in terms of a note-value of a specified tempo.

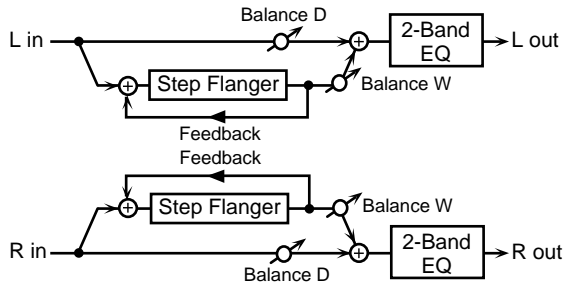

Flanger

Rate (LFO Rate)

Adjust the rate of modulation.

Depth (LFO Rate)

Adjust the depth of modulation.

Fbk (Feedback Level)

Adjust the amount (%) of the flanger sound that is returned (fed back) into the input. Negative (-) settings will invert the phase.

Feedback

Adjust the amount (%) of the processed sound that is returned (fed back) into the input. Positive (+) settings will return the sound in phase, and negative (-) settings will return the sound in reverse phase.

Phase

Adjust the spatial spread of the sound.

Pre Delay (Pre Delay Time)

Adjust the time delay from when the direct sound begins until the flanger sound is heard.

Step Rate

Step Rate

Adjust the rate (period) of pitch change. This parameter can be set as a note-value of a specified tempo. In this case, specify the value of the desired note.

EQ Gain

Low (LowGain)

Adjust the gain of the low frequency range.

High (High Gain)

Adjust the gain of the high frequency range.

Balance

Balance (Effect Balance)

Adjust the volume balance between the direct sound and the flanger sound. With a setting of D100:0W only the direct sound will be output, and with a setting of D0:100W only the chorus sound will be output.

Output

Level (Output Level)

Adjust the output level.

17: STEREO DELAY

This is a stereo delay.

When Feedback Mode is **NORMAL**:

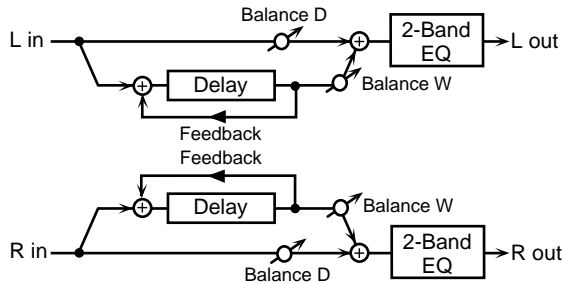

When Feedback Mode is **CROSS**:

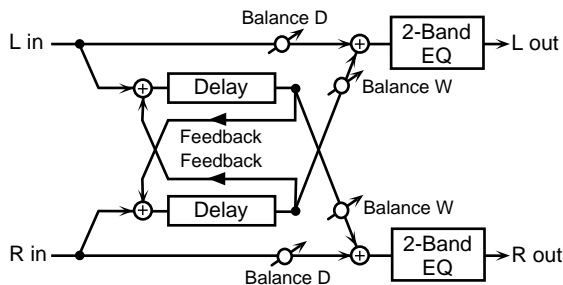

Delay

Left (Delay Time Left)

Adjust the time from the original sound until when the left delay sound is heard.

Right (Delay Time Right)

Adjust the time from the original sound until when the right delay sound is heard.

HF Damp

Adjust the frequency above which sound fed back to the effect will be cut. If you do not want to cut the high frequencies of the feedback, set this parameter to **BYPASS**.

Feedback

Adjust the proportion (%) of the delay sound that is fed back into the effect. Negative (-) settings will invert the phase.

FBK Mode (Feedback Mode)

Select the way in which delay sound is fed back into the effect.

NORMAL:The left delay sound will be fed back into the left delay, and the right delay sound into the right delay.

CROSS:The left delay sound will be fed back into the right delay, and the right delay sound into the left delay.

Phase

Phase Left

Select the phase of the left delay sound.

NORMAL:Phase is not changed.

INVERT:Phase is inverted.

Phase Right

Select the phase of the right delay sound.

NORMAL:Phase is not changed.

INVERT:Phase is inverted.

EQ Gain**Low (LowGain)**

Adjust the gain of the low frequency range.

High (High Gain)

Adjust the gain of the high frequency range.

Balance**Balance (Effect Balance) #**

Adjust the volume balance between the direct sound and the delay sound. With a setting of D100:0W only the direct sound will be output, and with a setting of D0:100W only the delay sound will be output.

Output**Level (Output Level)**

Adjust the output level.

18: MODULATION DELAY

This effect adds modulation to the delayed sound, producing an effect similar to a flanger.

When Feedback Mode is NORMAL:

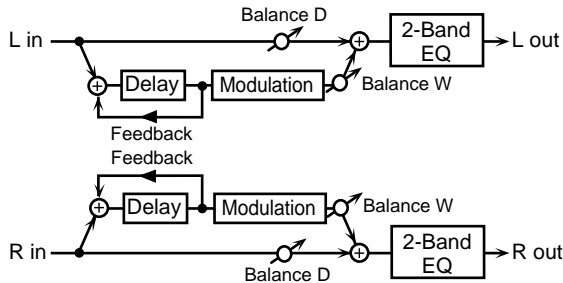

When Feedback Mode is CROSS:

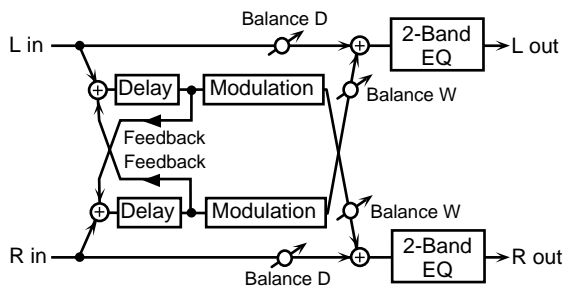

Delay

Left (Delay Time Left)

Adjust the time from the original sound until when the left delay sound is heard.

Right (Delay Time Right)

Adjust the time from the original sound until when the right delay sound is heard.

HF Damp

Adjust the frequency above which sound fed back to the effect will be cut. If you do not want to cut the high frequencies of the feedback, set this parameter to BYPASS.

Feedback (Feedback Level)

Adjust the proportion (%) of the delay sound that is fed back into the effect. Negative (-) settings will invert the phase.

FBK Mode (Feedback Mode)

Select the way in which delay sound is fed back into the effect.

NORMAL:The left delay sound will be fed back into the left delay, and the right delay sound into the right delay.

CROSS:The left delay sound will be fed back into the right delay, and the right delay sound into the left delay.

Modulation

Rate

Adjust the speed of the modulation.

Depth

Adjust the depth of the modulation.

Phase

Adjust the spatial spread of the sound.

EQ Gain**Low (Low Gain)**

Adjust the gain of the low frequency range.

High (High Gain)

Adjust the gain of the high frequency range.

Balance**Balance (Effect Balance) #**

Adjust the volume balance between the direct sound and the modulation delay sound. With a setting of D100:0W only the direct sound will be output, and with a setting of D0:100W only the modulation delay sound will be output.

Output**Level (Output Level)**

Adjust the output level.

19: TRIPLE TAP DELAY

The Triple Tap Delay produces three delay sounds; center, left and right. The center delay time can be specified as a note value of a specified tempo.

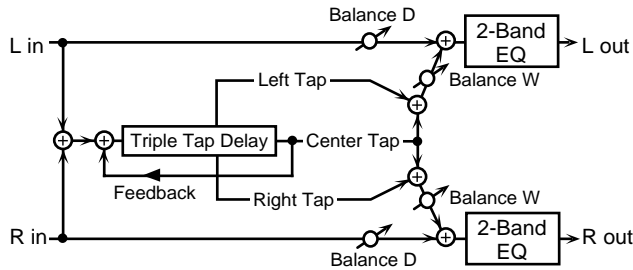

Delay

Center (Delay Time Center)

Left (Delay Time Left)

Right (Delay Time Right)

Adjust the time delay from the direct sound until when the delay sound is heard. This parameter can be set as a note-value of a specified tempo. In this case, specify the value of the desired note.

HF Damp

Adjust the frequency above which sound fed back to the effect will be cut. If you do not want to cut the high frequencies of the feedback, set this parameter to BYPASS.

Feedback

Adjust the proportion (%) of the delay sound that is fed back into the effect. Negative (-) settings will invert the phase.

Delay Level

Center (Center Level)

Left (Left Level)

Right (Right Level)

Adjust the volume of each delay sound.

EQ Gain

Low (Low Gain)

Adjust the gain of the low frequency range.

High (High Gain)

Adjust the gain of the high frequency range.

Balance

Balance (Effect Balance)

Adjust the volume balance between the direct sound and the delay sound. With a setting of D100:0W only the direct sound will be output, and with a setting of D0:100W only the delay sound will be output.

Output

Level (Output Level)

Adjust the output level.

20: QUADRUPLE TAP DELAY

The Quadruple Tap Delay has four delays. Each of the Delay Time parameters can be specified as a note length of the selected tempo.

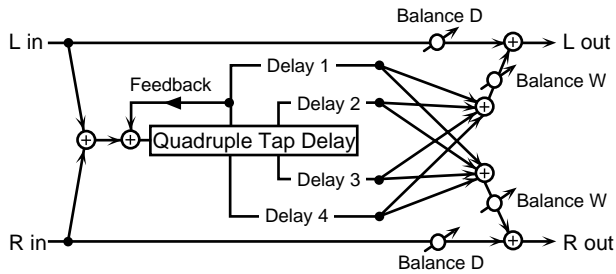

The stereo location of each delay sound is as follows.

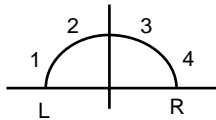

Delay

Delay 1 (Delay Time 1)

Delay 2 (Delay Time 2)

Delay 3 (Delay Time 3)

Delay 4 (Delay Time 4)

Adjust the time delay from the direct sound until when each delay sound is heard. These parameters can be set as a note-value of a specified tempo. In this case, specify the value of the desired note.

HF Damp

Adjust the frequency above which sound fed back to the effect will be cut. If you do not want to cut the high frequencies of the feedback, set this parameter to BYPASS.

Feedback (Feedback Level)

Adjust the proportion (%) of the delay sound that is fed back into the effect. Negative (-) settings will invert the phase.

Delay Level

Level 1

Level 2

Level 3

Level 4

Adjust the volume of each delay sound.

Balance

Balance (Effect Balance)

Adjust the volume balance between the direct sound and the delay sound. With a setting of D100:0W only the direct sound will be output, and with a setting of D0:100W only the delay sound will be output.

Output

Level (Output Level)

Adjust the output level.

21: TIME CONTROL DELAY

This effect allows you to use a specified controller (the controller selected in EFX Control Source) to control the delay time and pitch in realtime. Lengthening the delay will lower the pitch, and shortening it will raise the pitch.

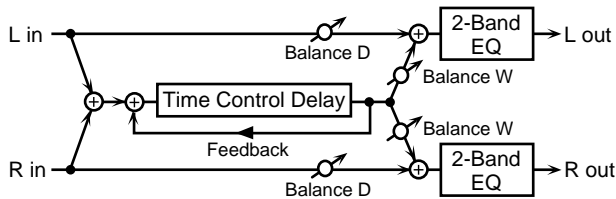

Delay

Time (Delay time)

Adjust the time delay from the direct sound until when each delay sound is heard.

Acceleration

This parameter adjusts the time over which the Delay Time will change from the current setting to a newly specified setting. The rate of change for the Delay Time directly affects the rate of pitch change.

HF Damp

Adjust the frequency above which sound fed back to the effect will be cut. If you do not want to cut the high frequencies of the feedback, set this parameter to BYPASS.

Feedback

Adjust the proportion (%) of the delay sound that is fed back into the effect. Negative (-) settings will invert the phase.

EQ Gain

Low (Low Gain)

Adjust the gain of the low frequency range.

High (High Gain)

Adjust the gain of the high frequency range.

Balance

Balance (Effect Balance)

Adjust the volume balance between the direct sound and the delay sound. With a setting of D100:0W only the direct sound will be output, and with a setting of D0:100W only the delay sound will be output.

Output

Level (Output Level)

Adjust the output level.

Pan (Output Pan)

Adjust the stereo location of the delay sound. L64 is far left, 0 is center, and 63R is far right.

22: 2VOICE PITCH SHIFTER

A Pitch Shifter shifts the pitch of the original sound. This 2-voice pitch shifter has two pitch shifters, and can add two pitch shifted sounds to the original sound.

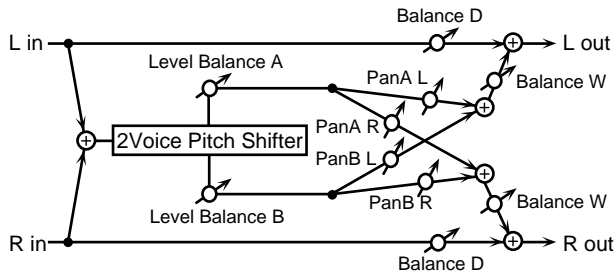

Pitch A

Coarse (Coarse Pitch A) #1

Adjust the pitch of Pitch Shift A in semitone steps (-2-+1 octaves).

Fine (Fine Pitch A) #1

Make fine adjustments to the pitch of Pitch Shift A in 2-cent steps (-100-+100 cents).

One cent is 1/100th of a semitone.

Pan (Output Pan A)

Adjust the stereo location of the Pitch Shift A sound. L64 is far left, 0 is center, and 63R is far right.

Pre Delay (Pre Delay Time A)

Adjust the time delay from when the direct sound begins until the Pitch Shift A sound is heard.

Pitch shift

Mode (Pitch Shifter Mode)

Higher settings of this parameter will result in slower response, but steadier pitch.

Pitch B

Coarse (Coarse Pitch B) #2

Adjust the pitch of Pitch Shift B in semitone steps (-2-+1 octaves).

Fine (Fine Pitch B) #2

Make fine adjustments to the pitch of Pitch Shift B in 2-cent steps (-100-+100 cents).

One cent is 1/100th of a semitone.

Pan (Output Pan B)

Adjust the stereo location of the Pitch Shift B sound. L64 is far left, 0 is center, and 63R is far right.

Pre Delay (Pre Delay Time B)

Adjust the time delay from when the direct sound begins until the Pitch Shift A sound is heard.

Level Balance

Level Balance

Adjust the volume balance between the Pitch Shift A and Pitch Shift B sounds.

Balance

Balance (Effect Balance)

Adjust the volume balance between the direct sound and the pitch shift sound. With a setting of D100:0W only the direct sound will be output, and with a setting of D0:100W only the pitch shift sound will be output.

Output

Level (Output Level)

Adjust the output level.

23: FBK PITCH SHIFTER (Feedback Pitch Shifter)

This pitch shifter allows the pitch shifted sound to be fed back into the effect.

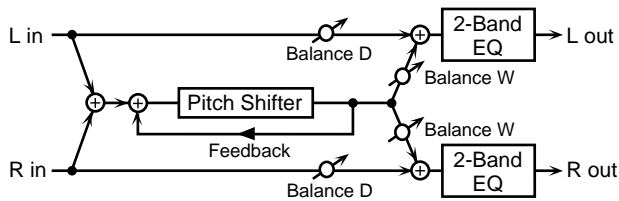

Pitch

Coarse (Coarse Pitch) #1

Adjust the pitch of the pitch shifted sound in semitone steps (-2--+1 octaves).

Fine (Fine Pitch) #1

Make fine adjustments to the pitch of the pitch shifted sound in 2-cent steps (-100--+100 cents).
One cent is 1/100th of a semitone.

Pre Delay (Pre Delay Time)

Adjust the time delay from when the direct sound begins until the pitch shifted sound is heard.

Mode (Pitch Shifter Mode)

Higher settings of this parameter will result in slower response, but steadier pitch.

Feedback (Feedback Level)

Adjust the proportion (%) of the pitch shift sound that is fed back into the effect. Negative (-) settings will invert the phase.

EQ Gain

Low (LowGain)

Adjust the gain of the low frequency range.

High (High Gain)

Adjust the gain of the high frequency range.

Balance

Balance (Effect Balance)

Adjust the volume balance between the direct sound and the pitch shift sound. With a setting of D100:0W only the direct sound will be output, and with a setting of D0:100W only the pitch shift sound will be output.

Output

Level (Output Level)

Adjust the output level.

Pan (Output Pan)

Adjust the stereo location of the pitch shifted sound. L64 is far left, 0 is center, and 63R is far right.

24: REVERB

The Reverb effect adds reverberation to the sound, simulating an acoustic space.

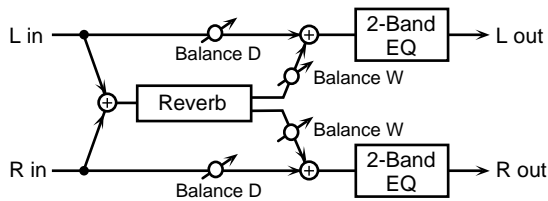

Reverb

Type (Reverb Type)

Select the type of Reverb effect.

ROOM1:dense reverb with short decay

ROOM2:sparse reverb with short decay

STAGE1:reverb with greater late reverberation

STAGE2:reverb with strong early reflections

HALL1:reverb with clear reverberance

HALL2:reverb with rich reverberance

Pre Delay (Pre Delay Time)

Adjust the time delay from when the direct sound begins until the reverb sound is heard.

Time (Reverb Time)

Adjust the time length of reverberation.

HF Damp

Adjust the frequency above which the reverberant sound will be cut. As the frequency is set lower, more of the high frequencies will be cut, resulting in a softer and more muted reverberance. If you do not want the high frequencies to be cut, set this parameter to BYPASS.

EQ Gain

Low (Low Gain)

Adjust the gain of the low frequency range.

High (High Gain)

Adjust the gain of the high frequency range.

Balance

Balance (Effect Balance)

Adjust the volume balance between the direct sound and the reverb sound. With a setting of D100:0W only the direct sound will be output, and with a setting of D0:100W only the reverb sound will be output.

Output

Level (Output Level)

Adjust the output level.

25: GATED REVERB

Gate Reverb is a special type of reverb in which the reverberant sound is cut off before its natural length.

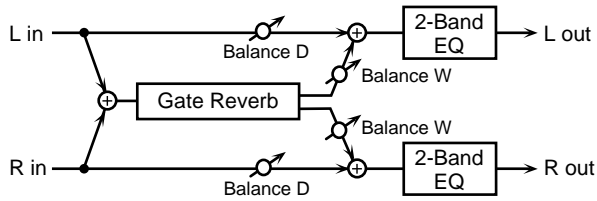

Reverb

Type (Gate Reverb Type)

Select the type of reverb.

NORMAL:conventional gate reverb

REVERSE:backwards reverb

SWEEP1:the reverberant sound moves from right to left

SWEEP2:the reverberant sound moves from left to right

Pre Delay (Pre Delay Time)

Adjust the time delay from when the direct sound begins until the reverb sound is heard.

Gate Time

Adjust the time from when the reverb is heard until when it disappears.

EQ Gain

Low (Low Gain)

Adjust the gain of the low frequency range.

High (High Gain)

Adjust the gain of the high frequency range.

Balance

Balance (Effect Balance)

Adjust the volume balance between the direct sound and the reverb sound. With a setting of D100:0W only the direct sound will be output, and with a setting of D0:100W only the reverb sound will be output.

Output

Level (Output Level)

Adjust the output level.

26: OVERDRIVE→CHORUS

This effect connects an overdrive and a chorus in series.

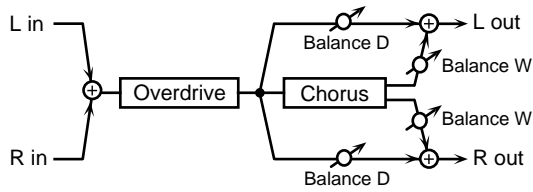

Overdrive

Drive

Adjust the degree of overdrive distortion. The volume will change together with the degree of distortion.

Pan (Overdrive Pan)

Adjust the stereo location of the overdrive sound. L64 is far left, 0 is center, and 63R is far right.

Chorus

Pre Delay (Chorus Pre Delay Time)

Adjust the time delay from when the direct sound begins until the chorus sound is heard.

Rate (Chorus Rate)

Adjust the modulation speed of the chorus effect.

Depth (Depth Rate)

Adjust the modulation depth of the chorus effect.

Balance (Chorus Balance)

Adjust the volume balance between the overdrive sound that is sent through the chorus and the overdrive sound that is not sent through the chorus. With a setting of "D100: 0W," only the overdrive sound will be output. With a setting of "D0: 100W," only the overdrive sound that is sent through the chorus will be output.

Output

Level (Output Level)

Adjust the output level.

27: OVERDRIVE→FLANGER

This effect connects an overdrive and a flanger in series.

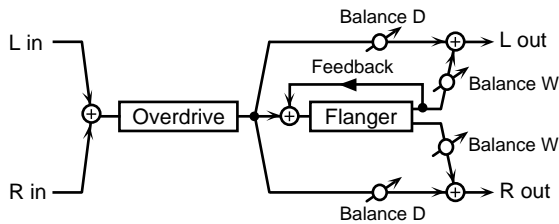

Overdrive

Drive

Adjust the degree of overdrive distortion. The volume will change together with the degree of distortion.

Pan (Overdrive Pan)

Adjust the stereo location of the overdrive sound. L64 is far left, 0 is center, and 63R is far right.

Flanger

Pre Delay (Flanger Pre Delay Time)

Adjust the time delay from when the direct sound begins until the flanger sound is heard.

Rate (Flanger Rate)

Adjust the modulation speed of the flanger effect.

Depth (Flanger Depth)

Adjust the modulation depth of the flanger effect.

Feedback (Flanger Feedback)

Adjust the proportion (%) of the flanger sound that is fed back into the effect. Negative (-) settings will invert the phase.

Balance (Flanger Balance)

Adjust the volume balance between the overdrive sound that is sent through the flanger and the overdrive sound that is not sent through the flanger. With a setting of "D100: 0W," only the overdrive sound will be output. With a setting of "D0: 100W," only the overdrive sound that is sent through the flanger will be output.

Output

Level (Output Level)

Adjust the output level.

28: OVERDRIVE→DELAY

This effect connects an overdrive and a delay in series.

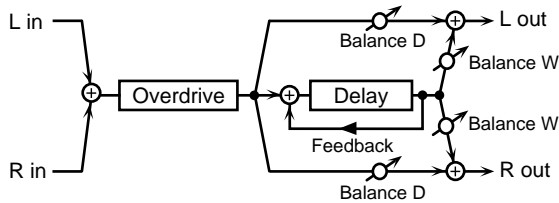

Overdrive

Drive

Adjust the degree of overdrive distortion. The volume will change together with the degree of distortion.

Pan (Overdrive Pan)

Adjust the stereo location of the overdrive sound. L64 is far left, 0 is center, and 63R is far right.

Delay

Time (Delay Time)

Adjust the time delay from when the direct sound begins until the delay sound is heard.

Feedback (Delay Feedback)

Adjust the proportion (%) of the delay sound that is fed back into the effect. Negative (-) settings will invert the phase.

HF Damp (Delay HF Damp)

Adjust the frequency above which delayed sound fed back to the effect will be cut. If you do not want to cut the high frequencies of the feedback, set this parameter to BYPASS.

Balance (Delay Balance)

Adjust the volume balance between the overdrive sound that is sent through the delay and the overdrive sound that is not sent through the delay. With a setting of "D100: 0W," only the overdrive sound will be output. With a setting of "D0: 100W," only the overdrive sound that is sent through the delay will be output.

Output

Level (Output Level)

Adjust the output level.

29: DISTORTION→CHORUS

This effect connects distortion and chorus in series. The parameters are essentially the same as “26: OVERDRIVE?CHORUS,” with the exception of the following two.

Drive → Specify the amount of distortion.

Pan → Specify the stereo location of the distortion sound.

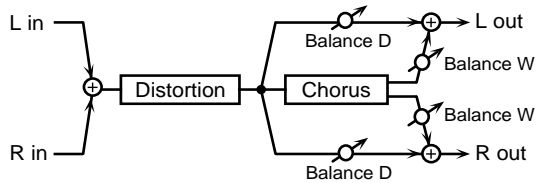

30: DISTORTION→FLANGER

This effect connects distortion and flanger in series. The parameters are essentially the same as in “27: OVERDRIVE?FLANGER,” with the exception of the following two.

Drive → Specify the amount of distortion.

Pan → Specify the stereo location of the distortion sound.

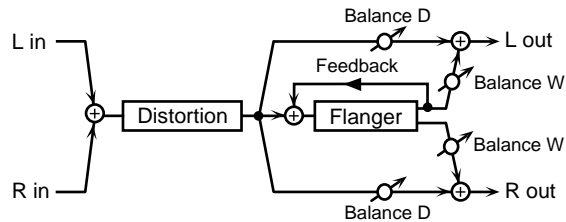

31: DISTORTION→DELAY

This effect connects distortion and delay in series. The parameters are essentially the same as in “28: OVERDRIVE?DELAY,” with the exception of the following two.

Drive → Specify the amount of distortion.

Pan → Specify the stereo location of the distortion sound.

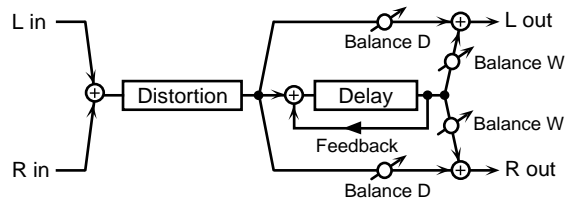

32: ENHANCER→CHORUS

This effect connects an enhancer and a chorus in series.

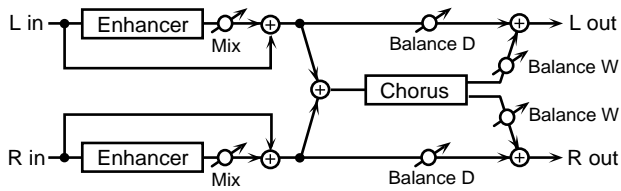

Enhancer

Sens (Enhancer Sens)

Adjust the sensitivity of the enhancer.

Mix Level (Enhancer Mix Level)

Adjust the ratio with which the overtones generated by the enhancer are combined with the direct sound.

Chorus

Pre Delay (Chorus Pre Delay Time)

Adjust the time delay from when the direct sound begins until the chorus sound is heard.

Rate (Chorus Rate)

Adjust the modulation speed of the chorus effect.

Depth (Chorus Depth)

Adjust the modulation depth of the chorus effect.

Balance (Chorus Balance)

Adjust the volume balance between the enhancer sound that is sent through the chorus and the enhancer sound that is not sent through the chorus. With a setting of "D100: 0W," only the enhancer sound will be output. With a setting of "D0: 100W," only the enhancer sound that is sent through the chorus will be output.

Output

Level (Output Level)

Adjust the output level.

33: ENHANCER→FLANGER

This effect connects an enhancer and a flanger in series.

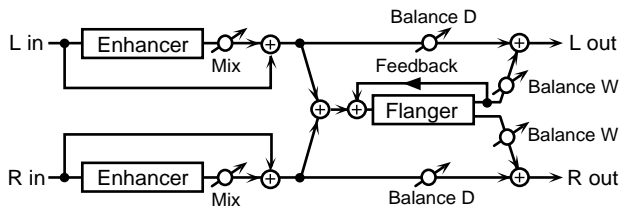

Enhancer

Sens

Adjust the sensitivity of the enhancer.

Mix Level (Enhancer Mix Level)

Adjust the ratio with which the overtones generated by the enhancer are combined with the direct sound.

Flanger

Pre Delay (Flanger Pre Delay Time)

Adjust the time delay from when the direct sound begins until the flanger sound is heard.

Rate (Flanger Rate)

Adjust the modulation speed of the flanger effect.

Depth (Flanger Depth)

Adjust the modulation depth of the flanger effect.

Feedback (Flanger Feedback Level)

Adjust the proportion (%) of the flanger sound that is fed back into the effect. Negative (-) settings will invert the phase.

Balance (Flanger Balance)

Adjust the volume balance between the enhancer sound that is sent through the flanger and the enhancer sound that is not sent through the flanger. With a setting of "D100: 0W," only the enhancer sound will be output. With a setting of "D0: 100W," only the enhancer sound that is sent through the flanger will be output.

Output

Level (Output Level)

Adjust the output level.

34: ENHANCER→DELAY

This effect connects an enhancer and a delay in series.

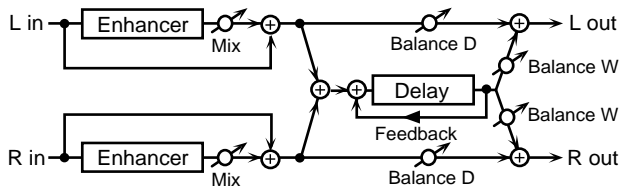

Enhancer

Sens

Adjust the sensitivity of the enhancer.

Mix Level (Enhancer Mix Level)

Adjust the ratio with which the overtones generated by the enhancer are combined with the direct sound.

Delay

Time (Delay Time)

Adjust the time delay from when the direct sound begins until the delay sound is heard.

Feedback (Delay Feedback)

Adjust the proportion (%) of the delay sound that is fed back into the delay input. Negative (-) settings will invert the phase.

HF Damp (Delay HF Damp)

Adjust the frequency above which delayed sound fed back to the delay input will be cut. If you do not want to cut the high frequencies of the delay feedback, set this parameter to BYPASS.

Balance (Delay Balance)

Adjust the volume balance between the enhancer sound that is sent through the delay and the enhancer sound that is not sent through the delay. With a setting of "D100: 0W," only the enhancer sound will be output. With a setting of "D0: 100W," only the enhancer sound that is sent through the delay will be output.

Output

Level (Output Level)

Adjust the output level.

35: CHORUS→DELAY

This effect connects a chorus and a delay unit in series.

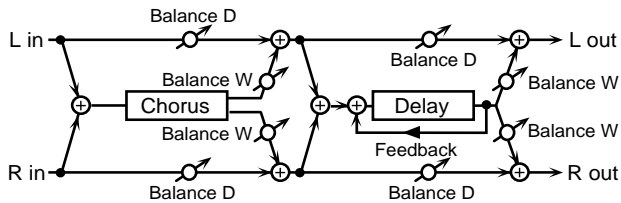

Chorus

Pre Delay (Chorus Pre Delay Time)

Adjust the time delay from when the direct sound begins until the chorus sound is heard.

Rate (Chorus Rate)

Adjust the modulation speed of the chorus effect.

Depth (Chorus Depth)

Adjust the modulation depth of the chorus effect.

Balance (Chorus Balance)

Adjust the volume balance between the direct sound and the chorus sound. With a setting of "D100: 0W," only the direct sound will be output. With a setting of "D0: 100W," only the chorus sound will be output.

Delay

Time (Delay Time)

Adjust the time delay from when the direct sound begins until the delay sound is heard.

Feedback (Delay Feedback)

Adjust the proportion (%) of the delay sound that is fed back into the delay input. Negative (-) settings will invert the phase.

HF Damp (Delay HF Damp)

Adjust the frequency above which delayed sound fed back to the delay input will be cut. If you do not want to cut the high frequencies of the feedback, set this parameter to BYPASS.

Balance (Delay Balance)

Adjust the volume balance between the chorus sound that is sent through the delay and the chorus sound that is not sent through the delay. With a setting of "D100: 0W," only the chorus sound will be output. With a setting of "D0: 100W," only the chorus sound that is sent through the delay will be output.

Output

Level (Output Level)

Adjust the output level.

36: FLANGER→DELAY

This effect connects a flanger and a delay in series.

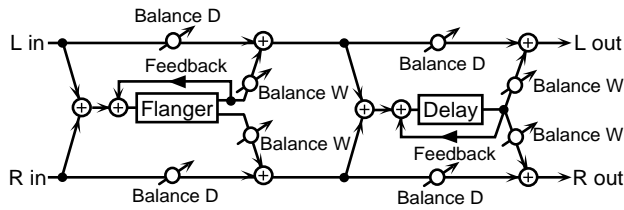

Flanger

Pre Delay (Flanger Pre Delay Time)

Adjust the time delay from when the direct sound begins until the flanger sound is heard.

Rate (Flanger Rate)

Adjust the modulation speed of the flanger effect.

Depth (Flanger Depth)

Adjust the modulation depth of the flanger effect.

Feedback (Flanger Feedback)

Adjust the proportion (%) of the flanger sound that is fed back into the effect. Negative (-) settings will invert the phase.

Balance (Flanger Balance)

Adjust the volume balance between the direct sound and the flanger sound. With a setting of "D100: 0W," only the direct sound will be output. With a setting of "D0: 100W," only the flanger sound will be output.

Delay

Time (Delay Time)

Adjust the time delay from when the direct sound begins until the delay sound is heard.

Feedback (Delay Feedback)

Adjust the proportion (%) of the delay sound that is fed back into the delay input. Negative (-) settings will invert the phase.

HF Damp (Delay HF Damp)

Adjust the frequency above which delayed sound fed back to the delay input will be cut. If you do not want to cut the high frequencies of the delay feedback, set this parameter to BYPASS.

Balance

Adjust the volume balance between the flanger sound that is sent through the delay and the flanger sound that is not sent through the delay. With a setting of "D100: 0W," only the flanger sound will be output. With a setting of "D0: 100W," only the flanger sound that is sent through the delay will be output.

Output

Level (Output Level)

Adjust the output level.

37: CHORUS→FLANGER

This effect connects a chorus and a flanger in series.

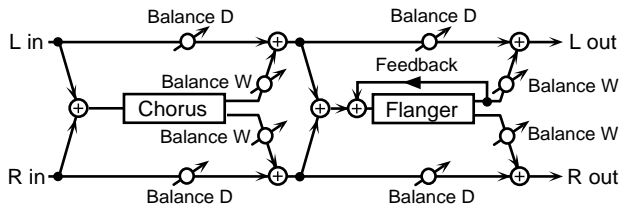

Chorus

Pre Delay (Chorus Pre Delay Time)

Adjust the time delay from when the direct sound begins until the chorus sound is heard.

Rate (Chorus Rate)

Adjust the modulation speed of the chorus effect.

Depth (Chorus Depth)

Adjust the modulation depth of the chorus effect.

Balance (Chorus Balance)

Adjust the volume balance between the direct sound and the chorus sound. With a setting of "D100: 0W," only the direct sound will be output. With a setting of "D0: 100W," only the chorus sound will be output.

Flanger

Pre Delay (Flanger Pre Delay Time)

Adjust the time delay from when the direct sound begins until the flanger sound is heard.

Rate (Flanger Rate)

Adjust the modulation speed of the flanger effect.

Depth (Flanger Depth)

Adjust the modulation depth of the flanger effect.

Feedback (Flanger Feedback Level)

Adjust the proportion (%) of the flanger sound that is fed back into the effect. Negative (-) settings will invert the phase.

Balance (Flanger Balance)

Adjust the volume balance between the chorus sound and the chorus sound that is passed through the flanger. With a setting of "D100: 0W," only the chorus sound will be output. With a setting of "D0: 100W," only the chorus sound that passes through the flanger will be output.

Output

Level (Output Level)

Adjust the output level.

38: CHORUS/DELAY

This effect connects a chorus and a delay in parallel. The parameters are the same as for “35: CHORUS→DELAY.” However, the Delay Balance parameter adjusts the volume balance between the direct sound and the delay sound.

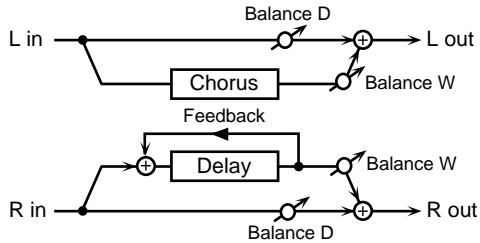

39: FLANGER/DELAY

This effect connects a flanger and a delay in parallel. The parameters are the same as for “36: FLANGER→DELAY.” However, the Delay Balance parameter adjusts the volume balance between the direct sound and the delay sound.

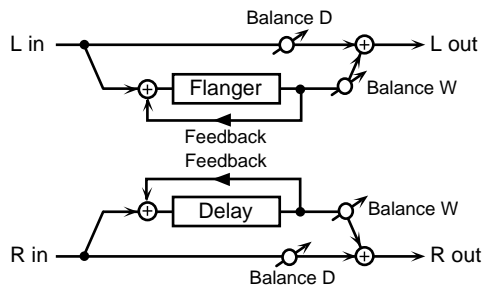

40: CHORUS/FLANGER

This effect connects a chorus and a flanger in parallel. The parameters are the same as for “37: CHORUS→FLANGER.” However, the Flanger Balance parameter adjusts the volume balance between the direct sound and the flanger sound.

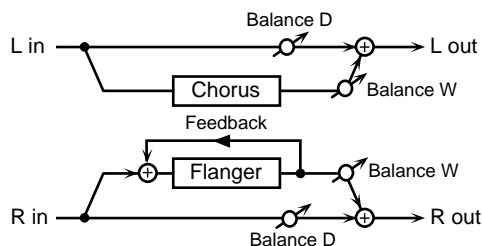

41:STEREO PHASER

This is a stereo phaser. With the Step effects, you can also make stepped changes in the pitch of sounds to which the Phaser effect is applied.

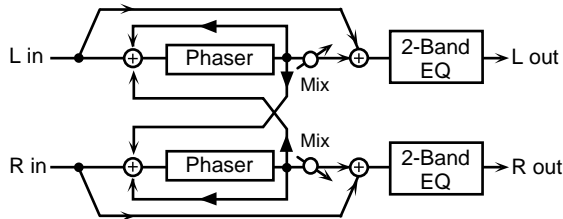

Phaser

Type (Phaser Type)

Selects the type of Phaser.

Type 2 adds more of the Phaser effect to the high frequencies than Type 1.

Mode

Selects the number of stages in the phaser (4/8-STAGE).

Polarity

Selects whether the left and right phase of the modulation will be the same or the opposite.

INVERSE:The left and right phase will be opposite. When using a mono source, this spreads the sound.

SYNCHRO:The left and right phase will be the same. Select this when inputting a stereo source.

Manual

Adjusts the center frequency to which the phase effect is applied.

Rate (Phaser Rate)

Adjust the frequency of modulation.

Depth (Phaser Depth)

Adjust the depth of modulation.

Resonance (Phaser Resonance)

Adjust the amount of feedback for the phaser. Higher settings will give the sound a stronger character.

X-Feedback (Cross Feedback Level)

Adjust the proportion (%) of the phaser sound that is to be returned to the input. Positive (+) settings will return the signal to the input with the original phase, while negative (-) settings produce an inverted phase.

Mix Level

Adjust the volume of the phase-shifted sound, relative to the direct sound.

Step Rate

Switch

This setting determines whether the pitch is changed in a stepped fashion (ON) or not (OFF).

Rate (Step Rate)

Adjust the frequency of pitch change.

EQ Gain

Low (Low Gain)

Adjust the low frequency gain (amount of boost or cut).

Positive (+) settings will emphasize (boost) the low frequency range.

High (High Gain)

Adjust the high frequency gain (amount of boost or cut).

Positive (+) settings will emphasize (boost) the high frequency range.

Output

Level (Output Level)

Adjust the output level.

42:KEYSYNC FLANGER

Keysync FLanger controls the Flanger by resetting the effect at the volume of the sound input to the effects device, restarting from the same pitch each time the Flanger is reset.

This parameter lets your playing dynamics on the keyboard control the flanger effect.

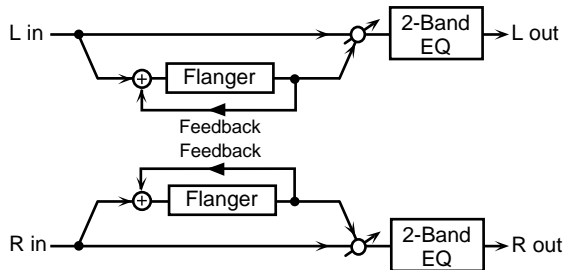

Flanger

PrDly (Pre Delay Time)

Adjust the time delay from the original sound until the flanger sound is heard.

Rate (LFO Rate)

Adjust the modulation frequency of the flanger sound.

Depth (LFO Depth)

Adjust the modulation depth of the flanger sound.

Fbk

Adjust the proportion (%) of the flanger sound that is to be returned to the input. Positive (+) settings will return the signal to the input with the original phase, while negative (-) settings produce an inverted phase. Higher settings will produce a more distinctive sound.

Phase

Adjust the spaciousness of the flanger sound.

Filter

Type

OFF:A filter will not be used.

LPF:the frequency region above the Cutoff Freq setting will be cut.

HPF:The frequency region below the Cutoff Freq setting will be cut.

Cutoff (Cutoff Frequency)

Sets the cutoff frequency when a specific frequency band is cut off by a filter.

Step Rate

Switch

This setting determines whether the pitch is changed in a stepped fashion (ON) or not (OFF).

Rate (Step Rate)

Adjust the frequency of pitch change.

Keysync

Switch (Keysync Switch)

Determines whether the Flanger LFO is reset according to the input sound (ON) or not (OFF).

Thre (Keysync Threshold)

Adjust the volume level for which reset will be applied.

Thres (Keysync Thres)

Sets the LFO phase when the LFO is reset.

Phase (Keysync Phase)

Sets the LFO phase when the LFO is reset.

EQ Gain

Low (Low Gain)

Adjust the low frequency range gain (amount of boost or cut).

Positive (+) settings will emphasize (boost) the low frequency range.

High (High Gain)

Adjust the high frequency gain (amount of boost or cut).

Positive (+) settings will emphasize (boost) the high frequency range.

Balance

Balance

Adjusts the volume balance between the direct sound and the flanger sound.

With a setting of D100:0W only the direct sound will be output, and with a setting of D0:100W only the flanger sound will be output.

Output

Level (Output Level) 0–127

Adjust the output level.

43:FORMANT FILTER

This adds a vowel character to the sound, making it similar to a human voice.

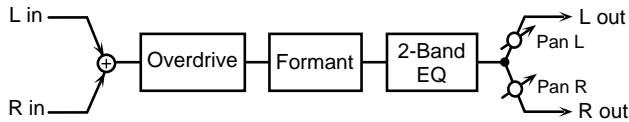

Overdrive

Switch

Determines whether the Overdrive is reset according to the input sound (ON) or not (OFF).

Drive

Turns Drive on/off.

Specifies the depth of distortion. The volume will change together with the degree of distortion.

Filter

Vowel 1, 2

Selects the vowel. The left setting is the vowel 1. The right setting is the vowel 2.

Rate

Sets the frequency at which the two vowels will be switched.

Depth

Sets the effect depth.

Manual

Sets the point at which the two vowels will be switched. When set to 50, Vowels 1 and 2 switched in the same amount of time. Setting this higher than 50 increases the time for Vowel 1; setting this lower than 50 decreases the time for Vowel 1.

Keysync

Switch (Keysync Switch)

Determines whether the LFO for switching the vowels is reset according to the input sound (ON) or not (OFF).

Thres (Keysync Threshold)

Specifies the volume level for which reset will be applied.

EQ Gain

Low (Low Gain)

Specifies the low frequency gain (amount of boost or cut).

Positive (+) settings will emphasize (boost) the low frequency range.

High (High Gain)

Specifies the high frequency gain (amount of boost or cut).

Positive (+) settings will emphasize (boost) the high frequency range.

Output

Level (Output Level)

Specifies the output volume.

Pan (Output Pan)

Specifies the stereo location of the output sound. L64 is far left, 0 is center, and 63R is far right.

44:RING MODULATOR

Ring Modulator is an effect which applies amplitude modulation (AM) to the input signal, producing bell-like sounds.

You can also change the modulation frequency according to the volume of the sound input to the effects device.

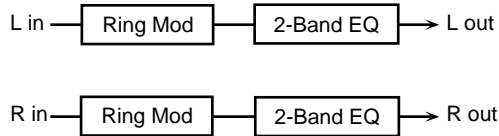

Ring Modulator

Freq (Frequency)

Sets the frequency at which modulation will be applied.

Modulator (Modulator Source)

Selects the input of the source sound for the envelope controlling the modulation.

When set to SOURCE, the frequency is modulated according to the envelope of the sound input to the multi-effects.

Modulator Monitor

Determines whether the input sound used as the modulator is output (ON) or not (OFF).

Sens

Sets the amount of frequency modulation applied.

Polarity

Determines whether the frequency modulation moves towards higher frequencies (UP) or lower frequencies (DOWN).

EQ Gain

Low (Low Gain)

Specifies the low frequency gain (amount of boost or cut).

Positive (+) settings will emphasize (boost) the low frequency range.

High (High Gain)

Specifies the high frequency gain (amount of boost or cut).

Positive (+) settings will emphasize (boost) the high frequency range.

Balance

Balance (Effect Balance)

Sets the volume balance between the source sound and the effect sound.

With a setting of D100:0W only the direct sound will be output, and with a setting of D0:100W the effect sound will be output.

Output

Level (Output Level)

Adjust the output level.

45: MULTI TAP DELAY

The Multi Tap Delay has four delays. Each of the Delay Time parameters can be specified as a note length of the selected tempo. You can also set the panning and level of each delay sound.

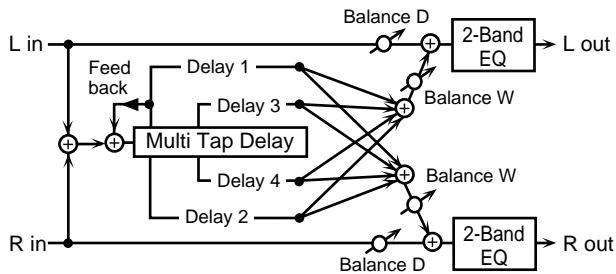

Delay

1 (Delay Time 1)

Adjust the delay time from the original sound until the delay 1 sound is heard.

2 (Delay Time 2)

Adjust the delay time from the original sound until the delay 2 sound is heard.

3 (Delay Time 3)

Adjust the delay time from the original sound until the delay 3 sound is heard.

4 (Delay Time 4)

Adjust the delay time from the original sound until the delay 4 sound is heard.

Feedback

Adjust the proportion (%) of the delay sound that is to be returned to the input. Positive (+) settings will return the signal to the input with the original phase, while negative (-) settings produce an inverted phase.

HF Damp

Adjust the frequency at which the high frequency range of the delayed sound returned to the input will be cut. If you do not want to cut the high frequencies of the feedback, set this parameter to BYPASS.

Level

1 (Level 1)

Adjust the output level of delay 1.

2 (Level 2)

Adjust the output level of delay 2.

3 (Level 3)

Adjust the output level of delay 3.

4 (Level 4)

Adjust the output level of delay 4.

Pan

1 (Output Pan 1)

Sets the stereo position of the delay sound (Delay 1). A setting of L64 is far left, 0 is center, and 63R is far right.

2 (Output Pan 2)

Sets the stereo position of the delay sound (Delay 2). A setting of L64 is far left, 0 is center, and 63R is far right.

3 (Output Pan 3)

Sets the stereo position of the delay sound (Delay 3). A setting of L64 is far left, 0 is center, and 63R is far right.

4 (Output Pan 4)

Sets the stereo position of the delay sound (Delay 4). A setting of L64 is far left, 0 is center, and 63R is far right.

EQ Gain**Low (Low Gain)**

Adjust the low frequency gain (amount of boost or cut).

Positive (+) settings will emphasize (boost) the low frequency range.

High (High Gain)

Adjust the high frequency gain (amount of boost or cut).

Positive (+) settings will emphasize (boost) the high frequency range.

Balance**Balance (Effect Balance) #**

Sets the volume balance between the source sound and the effect sound.

With a setting of D100:0W only the direct sound will be output, and with a setting of D0:100W only the effect sound will be output.

Output**Level (Output Level)**

Adjust the output level.

46: REVERSE DELAY

Reverse Delay is a delay effect that adds the reverse of the input sound as the delay sound.

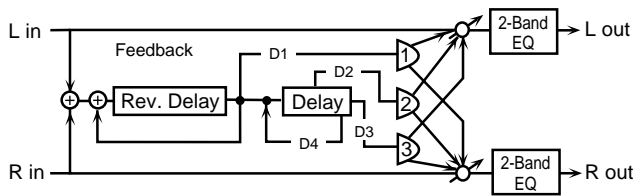

Delay

1 (Delay Time 1)

Adjust the delay time from the original sound until the delay 1 sound is heard.

2 (Delay Time 2)

Adjust the delay time from the original sound until the delay 2 sound is heard.

3 (Delay Time 3)

Adjust the delay time from the original sound until the delay 3 sound is heard.

4 (Delay Time 4)

Adjust the delay time from the original sound until the delay 4 sound is heard.

Feedback

Feedback 1:4

Adjust the proportion (%) of the delay 1 and 4 sound that is fed back into the effect. Positive (+) settings will return the signal to the input with the original phase, while negative (-) settings produce an inverted phase.

HF Damp

HF Damp 1:4

Adjust the frequency above which delayed sound (Delay 1, 4) fed back to the delay input will be cut. If you do not want to cut the high frequencies of the feedback, set this parameter to BYPASS.

Level 1:2:3

Adjust the output level of delay 1, 2 and 3.

Pan 1:2:3 (Output Pan 1:2:3)

Adjust the pan of delay sound (Delay 1, 2, 3). A setting of L64 is far left, 0 is center, and 63R is far right.

Threshold

Thresh (Threshold Level)

Specify the volume level at which the reverse delay will begin to apply.

EQ Gain

Low (Low Gain)

Adjust the low frequency gain (amount of boost or cut). Positive (+) settings will emphasize (boost) the low frequency range.

High (High Gain)

Adjust the high frequency gain (amount of boost or cut). Positive (+) settings will emphasize (boost) the high frequency range.

Balance

Balance (Effect Balance) #

Sets the volume balance between the source sound and the effect sound.

With a setting of D100:0W only the direct sound will be output, and with a setting of D0:100W only the effect sound will be output.

Output

Level (Output Level)

Adjust the output level.

47:SHUFFLE DELAY

Shuffle Delay adds a shuffle to the delay sound, giving the sound a bouncy delay effect with a swing feel.

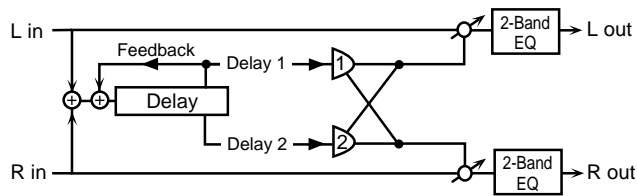

Delay

Time (Delay Time)

Adjust the delay time from the original sound until the delay sound is heard.

Shuffle Rate

Sets the ratio (as a percentage) of the time that elapses before the sound plays in Delay B relative to the time that elapses before the sound plays in Delay A. When set to 100%, the delay times are the same.

Acceleration

Adjust the time over which the Delay Time will change from the current setting to a newly specified setting. The rate of change for the Delay Time directly affects the rate of pitch change.

Feedback

Adjust the proportion (%) of the delay sound that is to be returned to the input. Positive (+) settings will return the signal to the input with the original phase, while negative (-) settings produce an inverted phase.

HF Damp

Adjust the frequency above which delayed sound fed back to the delay input will be cut. If you do not want to cut the high frequencies of the feedback, set this parameter to BYPASS.

Pan

A (Pan A)

Adjust the pan of the delay A sound.

B (Pan B)

Adjust the pan of the delay B sound.

Balance

Balance (Level Balance)

Sets the balance for the levels of the delay A and the delay B.

EQ Gain

Low (Low Gain)

Adjust the low frequency gain (amount of boost or cut). Positive (+) settings will emphasize (boost) the low frequency range.

High (High Gain)

Adjust the high frequency gain (amount of boost or cut). Positive (+) settings will emphasize (boost) the high frequency range.

Balance

Balance (Effect Balance)

Sets the volume balance between the source sound and the effect sound.

With a setting of D100:0W only the direct sound will be output, and with a setting of D0:100W only the effect sound will be output.

Output

Level (Output Level)

Adjust the output level.

48:3D DELAY

This applies a 3D effect to the delay sound. The delay sound will be positioned 90 degrees left and 90 degrees right.

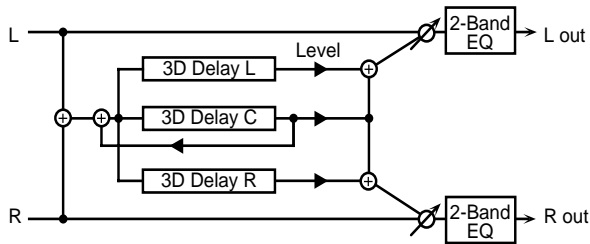

Delay

Center (Delay Time Center)

Adjust the delay time from the original sound until the center delay sound is heard.

Left (Delay Time Left)

Adjust the delay time from the original sound until the left delay sound is heard.

Right (Delay Time Right)

Adjust the delay time from the original sound until the right delay sound is heard.

HF Damp

Adjust the frequency above which delayed sound fed back to the delay input will be cut.

If you do not want to cut the high frequencies of the feedback, set this parameter to BYPASS.

Feedback

Adjust the proportion (%) of the delay sound that is to be returned to the input. Positive (+) settings will return the signal to the input with the original phase, while negative (-) settings produce an inverted phase.

Delay Level

Center (Level Center)

Adjust the volume of the left delay sound.

Left (Level Left)

Adjust the volume of the center delay sound.

Right (Level Right)

Adjust the volume of the right delay sound.

EQ Gain

Low (Low Gain)

Adjust the low frequency gain (amount of boost or cut).

Positive (+) settings will emphasize (boost) the low frequency range.

High (High Gain)

Adjust the high frequency gain (amount of boost or cut).

Positive (+) settings will emphasize (boost) the high frequency range.

Balance

Balance (Effect Balance) #

Sets the volume balance between the source sound and the effect sound.

With a setting of D100:0W only the direct sound will be output, and with a setting of D0:100W only the effect sound will be output.

Output

Out (Output Mode)

Adjust the method that will be used to hear the sound that is output to the OUTPUT jacks. The optimal 3D effect will be achieved if you select SPEAKER when using speakers, or PHONES when using headphones.

Level (Output Level)

Adjust the output level.

49:3VOICE PITCH SHIFTER

A Pitch Shifter shifts the pitch of the original sound. This 3-voice pitch shifter has three pitch shifters, and can add three pitch shifted sounds to the original sound.

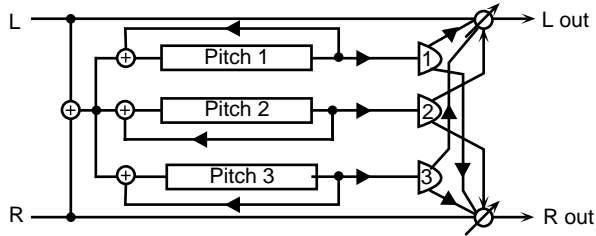

Pch Coarse

1:2:3 (Coarse Pitch 1:2:3) #1

Specify the pitch in semitones for pitch shift 1-3.

Pch Fine

1:2:3 (Fine Pitch 1:2:3) #1

Make fine adjustments to the pitch of the pitch shift 1-3 in 2-cent steps.

Pitch Shift

Mode (Pitch Shifter Mode)

Higher settings of this parameter will result in slower response, but steadier pitch.

Fbk 1:2:3 (Feedback Level 1:2:3)

Adjust the proportion (%) of the pitch shift 1-3 sound that is fed back into the effect.

Pre Delay 1:2:3 (Pre Delay Time 1:2:3)

Specify the time delay from the original sound until the pitch shift 1-3 sound is heard.

Balance

Balance (Effect Balance)

Sets the volume balance between the source sound and the effect sound.

With a setting of D100:0W only the direct sound will be output, and with a setting of D0:100W the effect sound will be output.

Level (Output Level)

Specifies the output volume.

Pan 1:2:3 (Output Pan 1:2:3)

Specify the stereo location of the pitch shift 1-3 sound. L64 is far left, 0 is center, and 63R is far right.

Output

Level (Output Level)

Adjust the output level.

50:LOFI COMPRESS

This is an effect that intentionally degrades the sound quality.

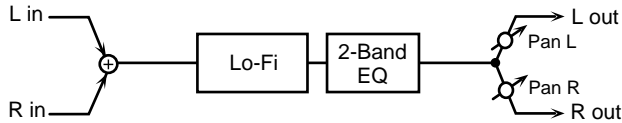

Lo-Fi

Type (LoFi Type)

Lowers the audio quality. The audio quality will worsen as this setting is increased.

Pre Filter

Type (Pre Filter Type)

Adjust the type of filter that will be applied before the sound passes through the Lo-Fi effect.

Post Filter 1

Type (Post Filter 1 Type)

Adjust the type of filter that will be applied after the sound passes through the Lo-Fi effect.

Post Filter 2

Type (Post Filter 2 Type)

OFF: A post filter 2 will not be used.

LPF: The frequency region above the Cutoff Freq setting will be cut.

HPF: The frequency region below the Cutoff Freq setting will be cut.

Cutoff (Cutoff Frequency)

Sets the cutoff frequency when a specific frequency band is cut off by a filter.

EQ Gain

Low (Low Gain)

Adjust the low frequency gain (amount of boost or cut).

Positive (+) settings will emphasize (boost) the low frequency range.

High (High Gain)

Adjust the high frequency gain (amount of boost or cut).

Positive (+) settings will emphasize (boost) the high frequency range.

Balance

Balance (Effect Balance)

Sets the volume balance between the source sound and the effect sound.

With a setting of D100:0W only the direct sound will be output, and with a setting of D0:100W only the effect sound will be output.

Output

Level (Output Level)

Adjust the output level.

Pan (Output Pan)

Adjust the stereo location of the output sound. A setting of L64 is far left, 0 is center, and 63R is far right.

51:LOFI NOISE

In addition to a Lo-Fi effect, this effect also generates various types of noise, such as radio noise and disc noise.

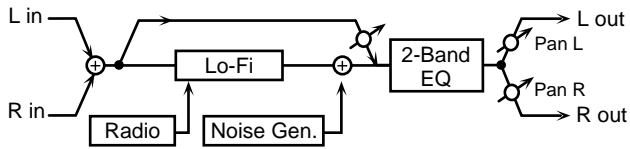

Lo-Fi

Type (LoFi Type)

Lowers the audio quality. The audio quality will worsen as this setting is increased.

Post Filter

Type (Post Filter Type)

OFF:A filter will not be used.

LPF:The frequency region above the Cutoff Freq setting will be cut.

HPF:The frequency region below the Cutoff Freq setting will be cut.

Cutoff (Cutoff Frequency)

Adjust the frequency at which the filter will begin cutting.

Radio Noise

Detune

Simulates the tuning noise of a radio. As this value is raised, the tuning will drift further.

Level

Adjust the volume of the radio noise.

Disc Noise

Type (Disc Noise Type)

Selects the type of record noise. The frequency at which the noise is heard will depend on the selected type.

LPF

Adjust the cutoff frequency of the low pass filter that is applied to the record noise.

Level (Disc Noise Level)

Adjust the volume of the record noise.

EQ Gain

Low (Low Gain)

Adjust the low frequency gain (amount of boost or cut).

Positive (+) settings will emphasize (boost) the low frequency range.

High (High Gain)

Adjust the high frequency gain (amount of boost or cut).

Positive (+) settings will emphasize (boost) the high frequency range.

Balance

Balance (Effect Balance) #

Sets the volume balance between the source sound and the effect sound.

With a setting of D100:0W only the direct sound will be output, and with a setting of D0:100W only the effect sound will be output.

Output

Level (Output Level)

Adjust the output level.

Pan (Output Pan)

Adjust the stereo position of the delay sound. A setting of L64 is far left, 0 is center, and 63R is far right.

52:SPEAKER SIMULATOR

Speaker Simulator is an effect that simulates the speaker type and mic settings used to record the speaker sound.

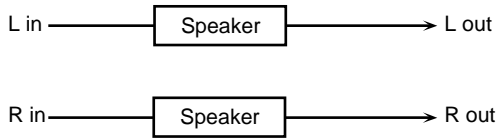

Speaker

Type (Speaker Type)

Select the type of speaker. The specifications of each type are as follows. The speaker column indicates the diameter of each speaker unit (in inches) and the number of units.

Type	Cabinet	Speaker	Microphone
SMALL 1	small open-back enclosure	10	dynamic mic
SMALL 2	small open-back enclosure	10	dynamic mic
MIDDLE	open back enclosure	12 x 1	dynamic mic
JC-120	open back enclosure	12 x 2	dynamic mic
BUILT IN 1	open back enclosure	12 x 2	dynamic mic
BUILT IN 2	open back enclosure	12 x 2	condenser mic
BUILT IN 3	open back enclosure	12 x 2	condenser mic
BUILT IN 4	open back enclosure	12 x 2	condenser mic
BUILT IN 5	open back enclosure	12 x 2	condenser mic
BG STACK 1	sealed enclosure	12 x 2	condenser mic
BG STACK 2	large sealed enclosure	12 x 2	condenser mic
MS STACK 1	large sealed enclosure	12 x 4	condenser mic
MS STACK 2	large sealed enclosure	12 x 4	condenser mic
METAL STACK	large double stack	12 x 4	condenser mic
2-STACK	large double stack	12 x 4	condenser mic
3-STACK	large triple stack	12 x 4	condenser mic

Mic

Setting (Mic Setting)

Adjust the location of the mic that is recording the sound of the speaker. This can be adjusted in three steps, with the mic becoming more distant in the order of 1, 2, and 3.

Level

Adjust the volume of the microphone.

Direct Level

Adjust the volume of the direct sound.

Output

Level (Output Level)

Adjust the output level.

53:OVERDRIVE 2

This is an overdrive that provides heavy distortion.

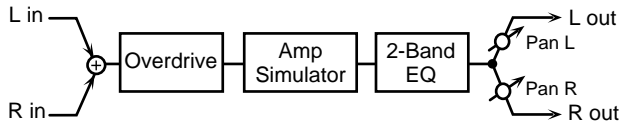

Overdrive

Drive

Adjust the amount of distortion. The volume will change together with the degree of distortion.

Tone

Adjust the sound quality of the Overdrive effect.

Amp Simulator

Switch

Turns the Amp Simulator on/off.

Type (Amp Simulator Type)

Adjust the type of guitar amp.

SMALL : small amp

BUILT-IN : single-unit type amp

2-STACK: large double stack amp

3-STACK: large triple stack amp

EQ Gain

Low (Low Gain)

Adjust the low frequency gain (amount of boost or cut).

Positive (+) settings will emphasize (boost) the low frequency range.

High (High Gain)

Adjust the high frequency gain (amount of boost or cut).

Positive (+) settings will emphasize (boost) the high frequency range.

Output

Level (Output Level)

Adjust the output level.

Pan (Output Pan)

Adjust the stereo location of the output sound. A setting of L64 is far left, 0 is center, and 63R is far right.

54: DISTORTION 2

This is a distortion effect that provides heavy distortion.

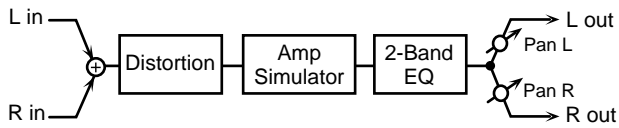

Distortion

Drive

Adjust the amount of distortion. The volume will change together with the degree of distortion.

Tone

Adjust the sound quality of the Overdrive effect.

Amp Simulator

Switch

Turns the Amp Simulator on/off.

Type (Amp Simulator Type)

Adjust the type of guitar amp.

SMALL : small amp

BUILT-IN : single-unit type amp

2-STACK: large double stack amp

3-STACK: large triple stack amp

EQ Gain

Low (Low Gain)

Adjust the low frequency gain (amount of boost or cut).

Positive (+) settings will emphasize (boost) the low frequency range.

High (High Gain)

Adjust the high frequency gain (amount of boost or cut).

Positive (+) settings will emphasize (boost) the high frequency range.

Output

Level (Output Level)

Adjust the output level.

Pan (Output Pan)

Adjust the stereo location of the output sound. A setting of L64 is far left, 0 is center, and 63R is far right.

55:STEREO COMPRESSOR

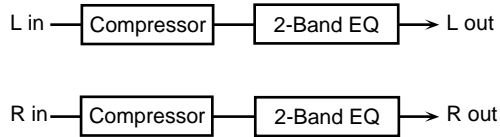

Compressor

Attack

Adjust the attack time of an input sound.

Sustain

Adjust the time over which low level sounds are boosted until they reach the specified volume.

Post Gain

Adjust the output gain.

EQ Gain

Low (Low Gain)

Adjust the low frequency gain (amount of boost or cut).

Positive (+) settings will emphasize (boost) the low frequency range.

High (High Gain)

Adjust the high frequency gain (amount of boost or cut).

Positive (+) settings will emphasize (boost) the high frequency range.

Output

Level (Output Level)

Adjust the output level.

56:STEREO LIMITER

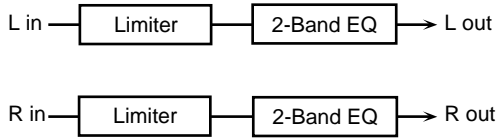

Limiter

Threshold (Threshold Level)

Adjust the volume at which compression will begin.

Ratio (Compression Ratio)

Adjust the compression ratio.

Release (Release Time)

Adjust the time from when the volume falls below the Threshold Level until compression is no longer applied.

Post Gain

Adjust the output gain.

EQ Gain

Low (Low Gain)

Adjust the low frequency gain.

High (High Gain)

Adjust the high frequency gain.

Output

Level (Output Level)

Adjust the output level.

57:GATE

The Gate effect cuts the reverb's delay according to the volume of the sound input to the effects device. Use this in situations such as when you want to force a decrease in the decay sound.

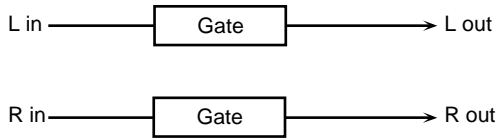

Gate

Mode

GATE (Gate Reverb):

When the source volume falls below a certain level, the gate closes, giving the effect of the reverb sound being cut with a gate reverb.

DUCK (Ducking Reverb):

When the source volume gets high enough, the gate closes, which gives a ducking reverb-type effect. Stop the reverb sound only when input loud sound so that prevent the play sound become unclear.

Attack Time

Sets the time it takes the gate fully opens after being triggered.

Hold Time

Sets the time it takes the gate starts closing after the instant the source sound goes under the threshold level.

Release Time

Sets the time it takes the gate fully closes after passes by the hold time.

Gate Key

Key

Selects the input of the sound that acts as the trigger closing the gate.

When set to SOURCE, the gate is closed by the sound input to the Multi-effects.

Threshold (Key Threshold)

Sets the volume level at which the gate begins to close.

Monitor (Key Monitor)

Determines whether the sound used as the gate trigger is output (ON) or not (OFF).

Balance

Balance (Effect Balance)

Sets the volume balance between the source sound and the effect sound.

With a setting of D100:0W only the direct sound will be output, and with a setting of D0:100W only the effect sound will be output.

Output

Level (Output Level)

Adjust the output level.

58:SLICER

By applying successive cuts to the sound, this effect turns a conventional sound into a sound that appears to be played as a backing phrase. This is especially effective when applied to sustain-type sounds.

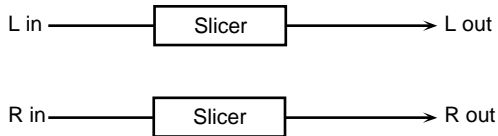

Level 1–4

Beat 1–4

For a single measure containing four quarter notes, this sets the level of each sixteenth-note when the measure is divided into sixteenth notes. When set to 0, no sound is output.

Rate

Rate

Determines the cycle for one measure.

Attack

Attack

Sets the speed at which the volume changes between beats. The higher the value, the faster the volume changes.

Reset

Trigger

Selects the input of the sound that acts as the trigger resetting the one-measure pattern.

When set to OFF, the pattern is not reset, even if the input is present. When set to Source, the pattern is reset by the sound input to the multi-effects. When RESET is selected as the MFX Control parameter, you can then use an external MIDI device to reset the pattern.

Threshold (Reset Threshold)

Sets the volume level at which the reset begins.

Monitor (Reset Monitor)

Determines whether the sound used as the reset trigger is output (ON) or not (OFF). This parameter is disabled when Reset is set to OFF or Source.

Beat Change

Mode

Sets the manner in which the volume changes as one beat progresses to the next.

LEGATO:

The change in volume from one beat's level to the next remains unaltered. If the level of a following beat is the same as the one preceding it, then there is no change in volume.

SLASH:

The level is momentarily set to 0 before progressing to the level for the next beat. This change in volume occurs even if the level of a following beat is the same as the one preceding it.

Shuffle

Sets the timing of volume changes in levels for even-numbered Beats (Beat 1-2/Beat 1-4/Beat 2-2/...). The higher the value selected, the later the timing with which the beat progresses.

Output

Level (Output Level)

Adjust the output level.

59:ISOLATOR

An equalizer which cuts the volume greatly, allowing you to add a special effect to the sound by cutting the volume in varying ranges.

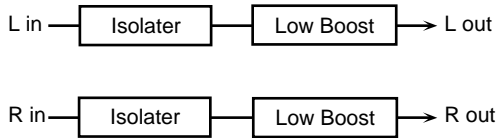

Boost/Cut

Low (Level Low) #

Mid (Level Middle) #

High (Level High) #

These boost and cut each of the High, Middle, and Low frequency ranges. At -60 dB, the sound becomes inaudible. 0 dB is equivalent to the input level of the sound.

Anti Phase Low

Switch (Anti Phase Low Switch)

This turns the Anti-Phase function on and off and sets the level settings for the Low frequency ranges. When turned on, the counter-channel of stereo sound is inverted and added to the signal.

Level (Anti Phase Low Level)

Adjusting these levels for certain frequencies allows you to lend emphasis to specific parts. (This is effective only for stereo source.)

Anti Phase Mid

Switch (Anti Phase Middle Switch)

This turns the Anti-Phase function on and off and sets the level settings for the Middle frequency ranges. When turned on, the counter-channel of stereo sound is inverted and added to the signal.

Level (Anti Phase Middle Level)

Adjusting these levels for certain frequencies allows you to lend emphasis to specific parts. (This is effective only for stereo source.)

Low Boost

Switch (Low Booster Switch)

Adjust whether Low Booster will be used (ON) or not (OFF). This emphasizes the bottom to create a heavy bass sound.

Increasing this value gives you a heavier low end. (Depending on the Isolator and filter settings this effect may be hard to distinguish.)

Level (Low Booster Level)

Adjust the level.

Output

Level (Output Level)

Adjust the output level.

60:3D CHORUS

This applies a 3D effect to the chorus sound. The chorus sound will be positioned 90 degrees left and 90 degrees right.

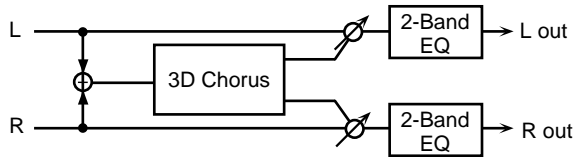

Chorus

Rate (LFO Rate)

Adjust the modulation frequency of the chorus sound.

Depth (LFO Depth)

Adjust the modulation depth of the chorus sound.

Phase

Adjust the spaciousness of the chorus sound.

Pre Delay (Pre Delay Time)

Adjust the delay time from the original sound until when the chorus sound is heard.

Filter

Type

OFF:A filter will not be used.

LPF:The frequency region above the Cutoff Freq setting will be cut.

HPF:The frequency region below the Cutoff Freq setting will be cut.

Cutoff (Cutoff Frequency)

Sets the cutoff frequency when a specific frequency band is cut off by a filter.

EQ Gain

Low (Low Gain)

Adjust the low frequency gain (amount of boost or cut).

Positive (+) settings will emphasize (boost) the low frequency range.

High (High Gain)

Adjust the high frequency gain (amount of boost or cut).

Positive (+) settings will emphasize (boost) the high frequency range.

Balance

Balance

Adjust the volume balance between the original sound and the flanger sound.

With a setting of D100:0W only the direct sound will be output, and with a setting of D0:100W only the flanger sound will be output.

Output

Out (Output Mode)

Adjust the method that will be used to hear the sound that is output to the OUTPUT jacks. The optimal 3D effect will be achieved if you select SPEAKER when using speakers, or PHONES when using headphones.

Level (Output Level)

Adjust the output level.

61:3D FLANGER

This applies a 3D effect to the flanger sound. The flanger sound will be positioned 90 degrees left and 90 degrees right.

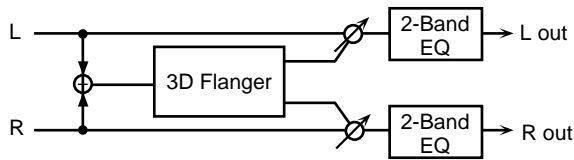

Flanger

Rate (LFO Rate)

Adjust the modulation speed of the flanger sound.

Depth (LFO Depth)

Adjust the modulation depth of the flanger sound.

Feedback

Adjust the proportion (%) of the flanger sound that is to be returned to the input. Positive (+) settings will return the signal to the input with the original phase, while negative (-) settings produce an inverted phase. Higher settings will produce a more distinctive sound.

Phase

Adjust the spaciousness of the flanger sound.

PrDly (Pre Delay Time)

Adjust the time delay from the direct sound until the flanger sound is heard.

Filter

Type

OFF:No filter is used.

LPF:The frequency region above the Cutoff Freq setting will be cut.

HPF:The frequency region below the Cutoff Freq setting will be cut.

Cutoff (Cutoff Frequency)

Sets the cutoff frequency when a specific frequency band is cut off by a filter.

Step Rate

Switch (Step Rate Switct)

Determines whether the pitch is changed in a stepped fashion (ON) or not (OFF).

Step Rate (Step Rate)

And adjust the rate at which the pitch will change.

EQ Gain

Low (Low Gain)

Adjust the low frequency gain (amount of boost or cut).

Positive (+) settings will emphasize (boost) the low frequency range.

High (High Gain)

Adjust the high frequency gain (amount of boost or cut).

Positive (+) settings will emphasize (boost) the high frequency range.

Balance

Balance

Adjust the volume balance between the original sound and the flanger sound.

With a setting of D100:0W only the direct sound will be output, and with a setting of D0:100W only the flanger sound will be output.

Output

Output (Output Mode)

Adjust the method that will be used to hear the sound that is output to the OUTPUT jacks. The optimal 3D effect will be achieved if you select SPEAKER when using speakers, or PHONES when using headphones.

Level (Output Level)

Adjust the output level.

62:TREMOLO

Tremolo cyclically modulates the volume to add tremolo effect to the sound.

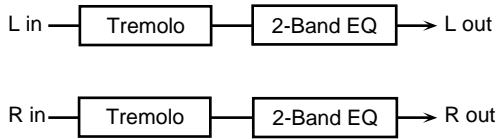

Tremolo

Mod Wave (Modulation Wave)

TRI: The sound will be modulated like a triangle wave.

SQR: The sound will be modulated like a square wave.

SIN: The sound will be modulated like a sine wave.

SAW1/2: The sound will be modulated like a sawtooth wave. The teeth in SAW1 and SAW2 point at opposite directions.



Rate

Adjust the frequency (speed) of the change.

Depth

Sets the depth to which the effect is applied.

EQ Gain

Low (Low Gain)

Adjust the low frequency gain (amount of boost or cut).

Positive (+) settings will emphasize (boost) the low frequency range.

High (High Gain)

Adjust the high frequency gain (amount of boost or cut).

Positive (+) settings will emphasize (boost) the high frequency range.

Output

Level (Output Level)

Adjust the output level.

63:AUTO PAN

The Auto Pan effect cyclically modulates the stereo location of the sound.

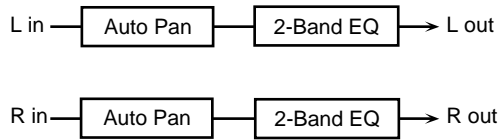

Auto Pan

Mod Wave (Modulation Wave)

TRI: The sound will be modulated like a triangle wave.

SQR: The sound will be modulated like a square wave.

SIN: The sound will be modulated like a sine wave.

SAW1/2: The sound will be modulated like a sawtooth wave. The teeth in SAW1 and SAW2 point at opposite directions.



Rate

Adjust the frequency (speed) of the change.

Depth

Sets the depth to which the effect is applied.

EQ Gain

Low (Low Gain)

Adjust the low frequency gain (amount of boost or cut).

Positive (+) settings will emphasize (boost) the low frequency range.

High (High Gain)

Adjust the high frequency gain (amount of boost or cut).

Positive (+) settings will emphasize (boost) the high frequency range.

Output

Level (Output Level)

Adjust the output level.

64: STEREO PHASER 2

This is a stereo phaser.

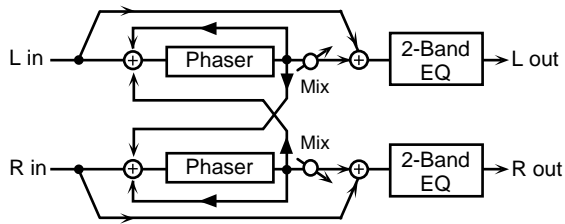

Phaser

Type (Phaser Type)

Selects the type of Phaser.

Type 2 adds more of the Phaser effect to the high frequencies than Type 1.

Mode

Selects the number of stages in the phaser (4/8/12/16).

Polarity

Selects whether the left and right phase of the modulation will be the same or the opposite.

INVERSE: The left and right phase will be opposite. When using a mono source, this spreads the sound.

SYNCHRO: The left and right phase will be the same. Select this when inputting a stereo source.

Manual

Adjusts the center frequency to which the phase effect is applied.

Rate (Phaser Rate)

Specifies the frequency of modulation.

Depth (Phaser Depth)

Adjusts the depth of modulation.

Resonance (Phaser Resonance)

Adjusts the amount of feedback for the phaser. Higher settings will give the sound a stronger character.

X-Feedback (Cross Feedback Level)

Adjusts the proportion (%) of the phaser sound that is to be returned to the input. Positive (+) settings will return the signal to the input with the original phase, while negative (-) settings produce an inverted phase.

Mix Level (Mix Level)

Specifies the volume of the phase-shifted sound, relative to the direct sound.

Step Rate

Switch (Step Switch)

Determines whether the pitch is changed in a stepped fashion (ON) or not (OFF).

Rate (Step Rate)

Adjusts the rate (period) of pitch change.

EQ Gain

Low (Low Gain)

Adjusts the gain of the low frequency range.

Positive (+) settings will emphasize (boost) the low-frequency range.

High (High Gain)

Adjusts the gain of the high frequency range.

Positive (+) settings will emphasize (boost) the high-frequency range.

Output

Level (Output Level)

Adjusts the output level.

65: STEREO AUTO WAH

This is a stereo auto wah.

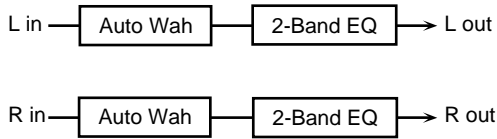

Auto Wah

Filter Type

Selects the type of filter.

LPF: The wah effect will be applied over a wide frequency range.

BPF: The wah effect will be applied over a narrow frequency range.

Sens

Adjusts the sensitivity with which the filter is controlled.

Manual

Adjusts the center frequency from which the wah effect is applied.

Peak

Adjusts the amount of the wah effect that will occur in the area of the center frequency.

Lower settings will cause the effect to be applied in a broad area around the center frequency. Higher settings will cause the effect to be applied in a more narrow range.

Rate (LFO Rate)

Adjusts the frequency of the modulation.

Depth (LFO Depth)

Adjusts the depth of the modulation.

Polarity (Auto Wah Polarity)

Sets the direction in which the frequency will change when the auto-wah filter is modulated. With a setting of Up, the filter will change toward a higher frequency. With a setting of Down, it will change toward a lower frequency.

Phase

Sets the degree of phase shift of the left and right sounds when the wah effect is applied.

EQ Gain

Low

Adjusts the gain of the low frequency range.

Positive (+) settings will emphasize (boost) the low-frequency range.

High

Adjusts the gain of the high frequency range.

Positive (+) settings will emphasize (boost) the high-frequency range.

Output

Level (Output Level)

Adjusts the output level.

66: ST FORMANT FILTER (Stereo Formant Filter)

This is a stereo formant filter.

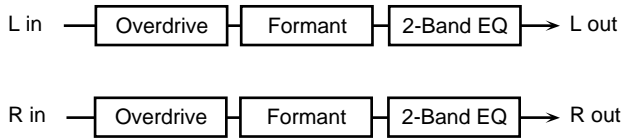

Overdrive

Switch (Drive Switch)

Turns Drive on/off.

Drive

Adjusts the degree of distortion. The volume will change together with the degree of distortion.

Filter

Vowel1

Selects vowel 1.

Vowel2

Selects vowel 2.

Rate

Sets the frequency at which the two vowels will be switched.

Depth

Sets the effect depth.

Manual

Sets the point at which the two vowels will be switched. When set to 50, Vowels 1 and 2 are switched after the same amount of time. Setting this higher than 50 increases the time for Vowel 1; setting this lower than 50 decreases the time for Vowel 1.

Phase

Sets the phase shift of the left and right sounds when the two vowels are switched.

Keysync

Switch (Keysync Switch)

Determines whether the LFO for switching the vowels is reset according to the input sound (ON) or not (OFF).

Thres

Adjusts the volume level at which reset will be applied.

EQ Gain

Low

Adjusts the gain of the low frequency range.

Positive (+) settings will emphasize (boost) the low-frequency range.

High

Adjusts the gain of the high frequency range.

Positive (+) settings will emphasize (boost) the high-frequency range.

Output

Level (Output Level)

Adjusts the output level.

67: MULTI TAP DELAY 2

This allows you to set even longer delay times (max. 3000 ms) for the Multi-Tap Delay function.

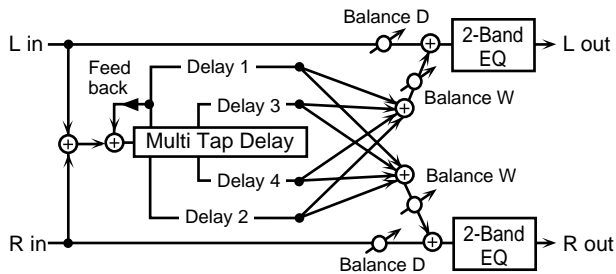

Delay

1–4 (Delay Time 1–4)

Adjusts the delay time from the direct sound until the delay 1 – 4 sound is heard.

Feedback

Adjusts the proportion (%) of the delay sound that is fed back into the delay input. Positive (+) settings will return the signal to the input with the original phase, while negative (-) settings produce an inverted phase.

HF Damp

Adjusts the frequency above which delayed sound fed back to the delay input will be cut. If you do not want to damp the high frequencies, set this parameter to BYPASS.

Level

1–4 (Delay Level 1–4)

Adjusts the output level of delay 1 – 4.

Pan

1–4 (Output Pan 1–4)

Sets the stereo position of the delay sound (Delay 1 – 4). L64 is far left, 0 is center, and 63R is far right.

EQ Gain

Low (Low Gain)

Adjusts the gain of the low frequency range. Positive (+) settings will emphasize (boost) the low-frequency range.

High (High Gain)

Adjusts the gain of the high frequency range. Positive (+) settings will emphasize (boost) the high-frequency range.

Balance

Balance (Effect Balance)

Sets the volume balance between the direct sound and the effect sound.

With a setting of D100:0W only the direct sound will be output, and with a setting of D0:100W only the effect sound will be output.

Output

Level (Output Level)

Adjusts the output level.

68: REVERSE DELAY 2

This allows you to set even longer delay times (max. 1500 ms) for the Multi-Tap Delay function.

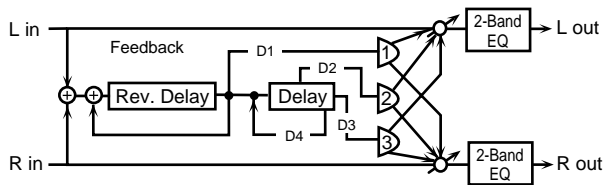

Delay

1-4 (Delay Time 1-4)

Adjusts the delay time from the direct sound until the delay 1 - 4 sound is heard.

Feedback

1, 4 (Feedback 1, 4)

Adjusts the proportion (%) of the delay 1 sound that is fed back into the effect. Positive (+) settings will return the signal to the input with the original phase, while negative (-) settings produce an inverted phase.

HF Damp

1, 4 (HF Damp 1, 4)

Adjusts the frequency above which delayed sound (delay 1, 4) fed back to the delay input will be cut. If you do not want to damp the high frequencies, set this parameter to BYPASS.

Level

1-3 (Delay Level 1-3)

Sets the volume level of the delay sound (Delay 1 - 3).

Pan

1-3 (Output Pan 1-3)

Sets the stereo position of the delay sound (Delay 1). L64 is far left, 0 is center, and 63R is far right.

Threshold

Value

Specifies the volume level at which the reverse delay will begin to apply.

EQ Gain

Low (Low Gain)

Adjusts the gain of the low frequency range.

Positive (+) settings will emphasize (boost) the low-frequency range.

High (High Gain)

Adjusts the gain of the high frequency range.

Positive (+) settings will emphasize (boost) the high-frequency range.

Balance

Balance (Effect Balance) #

Sets the volume balance between the direct sound and the effect sound.

With a setting of D100:0W only the direct sound will be output, and with a setting of D0:100W the effect sound will be output.

Output

Level (Output Level)

Adjusts the output level.

69: SHUFFLE DELAY 2

This allows you to set even longer delay times (max. 3000 ms) for the Shuffle Delay function.

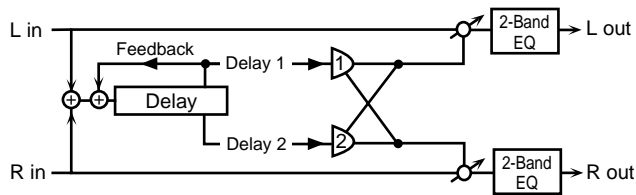

Delay

Time (Delay Time)

Adjusts the delay time from the direct sound until the delay sound is heard.

Shuffle Rate

Sets the ratio (as a percentage) of the time that elapses before the sound plays in Delay B relative to the time that elapses before the sound plays in Delay A. When set to 100%, the delay times are the same.

Acceleration

Adjusts the time over which the Delay Time will change from the current setting to a newly specified setting.

Feedback

Adjusts the proportion (%) of the delay sound that is fed back into the delay input. Positive (+) settings will return the signal to the input with the original phase, while negative (-) settings produce an inverted phase.

HF Damp

Adjusts the frequency above which delayed sound fed back to the delay input will be cut.

If you do not want to damp the high frequencies, set this parameter to BYPASS.

Pan

A, B (Pan A, B)

Adjusts the pan of the delay A, B sound.

Balance

Balance (Level Balance)

Sets the balance for the levels of the delay A and the delay B.

EQ Gain

Low (Low Gain)

Adjusts the gain of the low frequency range.

Positive (+) settings will emphasize (boost) the low-frequency range.

High (High Gain)

Adjusts the gain of the high frequency range.

Positive (+) settings will emphasize (boost) the high-frequency range.

Balance

Balance (Effect Balance)

Sets the volume balance between the direct sound and the effect sound.

With a setting of D100:0W only the direct sound will be output, and with a setting of D0:100W only the effect sound will be output.

Output

Level (Output Level)

Adjusts the output level.

70: 3D DELAY 2

This allows you to set even longer delay times (max. 3000 ms) for the 3D Delay function.

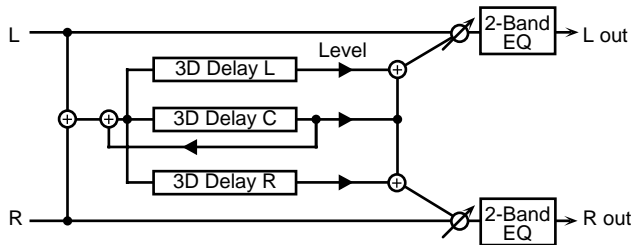

Delay

Center (Delay Time Center)

Adjusts the delay time from the direct sound until the center delay sound is heard.

Left (Delay Time Left)

Adjust the delay time from the original sound until the left delay sound is heard.

Right (Delay Time Right)

Adjust the delay time from the direct sound until the right delay sound is heard.

HF Damp

Adjusts the frequency above which delayed sound fed back to the delay input will be cut.

If you do not want to damp the high frequencies, set this parameter to BYPASS.

Feedback

Adjusts the proportion (%) of the delay sound that is fed back into the delay input. Positive (+) settings will return the signal to the input with the original phase, while negative (-) settings produce an inverted phase.

Delay Level

Center (Delay Level Center)

Adjusts the volume of the center delay sound.

Left (Delay Level Left)

Adjusts the volume of the left delay sound.

Right (Delay Level Right)

Adjusts the volume of the right delay sound.

EQ Gain

Low (Low Gain)

Adjusts the gain of the low frequency range.

Positive (+) settings will emphasize (boost) the low-frequency range.

High (High Gain)

Adjusts the gain of the high frequency range.

Positive (+) settings will emphasize (boost) the high-frequency range.

Balance

Balance (Effect Balance)

Sets the volume balance between the direct sound and the effect sound.

With a setting of D100:0W only the direct sound will be output, and with a setting of D0:100W the effect sound will be output.

Output

Out (Output Mode)

Specifies the method that will be used to reproduce the sound that is output to the OUTPUT jacks. The optimal 3D effect will be achieved if you select **SPEAKER** when using speakers, or **PHONES** when using headphones.

Level (Output Level)

Adjusts the output level.

71: ROTARY 2

This type provides modified response for the rotary speaker, with the low end boosted further.

This effect features the same specifications as the VK-7's built-in rotary speaker.

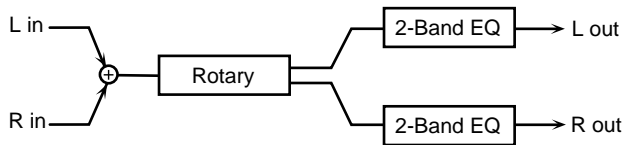

Rotary

Speed

Switches the rotational speed of the rotating speaker.

SLOW: The woofer rotates at the speed determined by the Woofer Speed Slow setting, and the tweeter rotates at the speed determined by the Tweeter Speed Slow setting.

FAST: The woofer rotates at the speed determined by the Woofer Speed Fast setting, and the tweeter rotates at the speed determined by the Tweeter Speed Fast setting.

Brake

Switches the rotation of the rotary speaker.

When this is turned on, the rotation will gradually stop. When it is turned off, the rotation will gradually resume.

Spread

Value

Sets the rotary speaker stereo image. The higher the value set, the wider the sound is spread out.

Woofer

Slow (Woofer Slow Rate)

Specifies the low-speed rotation speed of the woofer.

Fast (Woofer Fast Rate)

Specifies the high-speed rotation speed of the woofer.

Level (Woofer Level)

Sets the volume of the woofer.

Trans Up (Woofer Transition Up)

Sets the rate at which the woofer rotation speeds up when the rotation is switched from Slow to Fast. The higher the value, the faster the transition occurs.

Trans Down (Woofer Transition Down)

Sets the rate at which the woofer rotation speeds up when the rotation is switched from Fast to Slow. The higher the value, the faster the transition occurs.

Tweeter

Slow (Tweeter Slow Rate)

Specifies the low-speed rotation speed of the tweeter.

Fast (Tweeter Fast Rate)

Specifies the high-speed rotation speed of the tweeter.

Tweeter (Tweeter Level)

Specifies the volume of the tweeter.

Trans Up (Tweeter Transition Up)

Sets the rate at which the tweeter rotation speeds up when the rotation is switched from Slow to Fast. The higher the value, the faster the transition occurs.

Trans Down (Tweeter Transition Down)

Sets the rate at which the tweeter rotation speeds up when the rotation is switched from Fast to Slow. The higher the value, the faster the transition occurs.

EQ Gain

Low (Low Gain)

Adjusts the gain of the low frequency range.

Positive (+) settings will emphasize (boost) the low-frequency range.

High (High Gain)

Adjusts the gain of the high frequency range.

Positive (+) settings will emphasize (boost) the high-frequency range.

Output

Level (Output Level) #

Adjusts the output level.

72: ROTARY MULTI

This connects Overdrive/Distortion (ODDS), 3-band equalizer (EQ), and Rotary (RT) effects in series.

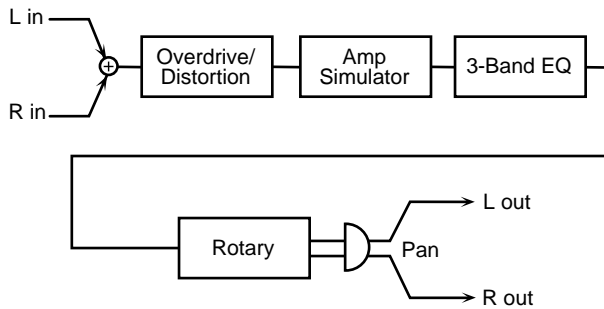

Sequence

OD/Dist (Overdrive/Distortion Switch)

Turns the Overdrive or Distortion on/off.

Amp Sim (Amp Simulator Switch)

Turns the Amp Simulator on/off.

3 Band EQ (3 Band EQ Switch)

Turns the 3 Band EQ on/off.

Rotary (Rotary Switch)

Turns the Rotary on/off.

Overdrive/Distortion

Type

Selects whether to use Overdrive or Distortion.

Drive

Adjusts the degree of distortion. The volume will change together with the degree of distortion.

Tone

Adjusts the sound quality of the Overdrive/Distortion effect.

Level

Adjusts the Overdrive/Distortion output level.

Amp Simulator

Type (Amp Type)

Selects the type of guitar amp.

EQ Gain

Low (EQ Low Gain)

Adjusts the low-range gain of the equalizer.

Mid (EQ Mid Gain)

Adjusts the gain of the area specified by the EQ M Fq parameter and the EQ M Q parameter.

High (EQ High Gain)

Adjusts the high-range gain of the equalizer.

Mid

Mid Freq (EQ Mid Frequency)

Sets the center frequency for the equalizer mid-range.

Mid Q (EQ Mid Q)

Adjusts the width of the area centered at the EQ M Fq setting in which the gain will be affected. Higher values of Q will result in a narrower area being affected.

Rotary

Speed

Simultaneously switch the rotational speed of both the low-range and the high-range rotors.

Slow: Slow down the rotation to the specified speeds (RT L Slow parameter/RT H Slow parameter values).

Fast: Speed up the rotation to the specified speeds (RT L Fast parameter/RT H Fast parameter values).

Separation

Adjusts the spatial spread of the rotary sound.

Woofers

Slow (Low Frequency Slow Rate)

Adjusts the speed of the low-range rotor for the slow-speed setting.

Fast (Low Frequency Fast Rate)

Adjusts the speed of the low-range rotor for the fast-speed setting.

Accel (Low Frequency Acceleration)

Adjusts the time over which the rotation speed of the low-range rotor will change from slow-speed to fast-speed (or fast-speed to slow-speed) rotation. Lower values will require longer times.

Level (Low Frequency Level)

Adjusts the volume of the low-range rotor.

Tweeter

Slow (High Frequency Slow Rate)

Adjusts the speed of the high-range rotor for the slow-speed setting.

Fast (High Frequency Fast Rate)

Adjusts the speed of the high-range rotor for the fast-speed setting.

Accel (High Frequency Acceleration)

Adjusts the time over which the rotation speed of the high-range rotor will change from slow-speed to fast-speed (or fast-speed to slow-speed) rotation. Lower values will require longer times.

Level (RT High Frequency Level)

Adjusts the volume of the high-range rotor.

Output

Level (Output Level)

Adjusts the output level.

Pan (Output Pan)

Adjusts the stereo location of the output sound.

73: KEYBOARD MULTI

Keyboard Multi provides Ring Modulator (RM), Equalizer (EQ), Pitch Shifter (PS), Phaser (PH) and Delay (Dly) effects connected in series.

Ring Modulator is an effect that applies amplitude modulation (AM) to the input signal, producing bell-like sounds.

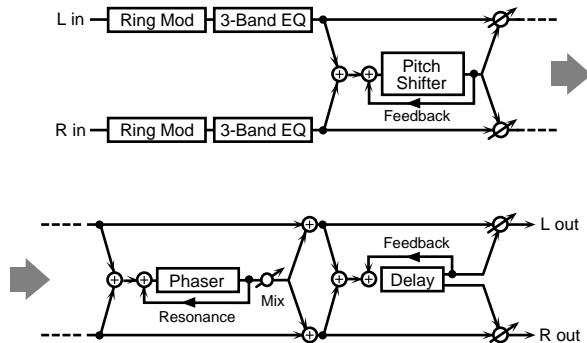

Sequence

Ring Mod (Ring Modulator Switch)

Turns the Ring Modulator on/off.

3 Band EQ Sw (3 Band EQ Switch)

Turns the equalizer on/off.

Pch Shift (Pitch Shifter Switch)

Turns the Pitch Shifter on/off.

Phaser (Phaser Switch)

Turns the Phaser on/off.

Delay (Delay Switch)

Turns the delay on/off.

* After turning the VALUE dial to select the effect, you can press [F1] or [F2] to rearrange the order in which effects are connected.

Ring Modulator

Freq (RM Frequency)

Sets the frequency at which modulation will be applied.

Balance (RM Balance)

Adjusts the balance between the direct and the ring modulated sound.

EQ Gain

Low (EQ Low Gain)

Adjusts the low-range gain of the equalizer.

Mid (EQ Mid Gain)

Adjusts the gain of the area specified by the EQ M Fq parameter and the EQ M Q parameter.

High (EQ High Gain)

Adjusts the high-range gain of the equalizer.

Mid (EQ Mid Frequency)

Sets the center frequency for the equalizer mid-range.

Mid Q (EQ Mid Q)

Adjusts the width of the area centered at the EQ M Fq setting in which the gain will be affected. Higher values of Q will result in a narrower area being affected.

Pitch Shifter

Mode (PS Shifter Mode)

Higher settings of this parameter will result in slower response, but steadier pitch.

Coarse Tune (PS Coarse Pitch) # *1

Adjusts the pitch of the pitch-shifted sound in semitone steps (-2- +1 octaves).

Fine Tune (PS Fine Pitch) # *1

Makes fine adjustments to the pitch of the pitch shifted sound in 2-cent steps (-100- +100 cents).

Delay (PS PreDelay)

Adjusts the time delay from when the direct sound begins until the pitch-shifted sound is heard.

Feedback (PS Feedback)

Adjusts the proportion (%) of the processed sound that is fed back into the effect.

Balance (PS Balance)

Adjusts the volume balance between the direct sound and the pitch shifted sound.

Phaser

Mode (Phaser Mode)

Selects the number of stages in the phaser.

Manual (Phaser Manual) #

Sets the center frequency at which the phaser sound will be modulated.

Rate (Phaser Rate) #

Adjusts the frequency of modulation.

Depth (Phaser Depth)

Specifies the depth of modulation.

Resonance (Phaser Resonance)

Adjusts the emphasis for the region around the center frequency specified by the PH Man parameter.

Mix Level(Phaser Mix)

Adjusts the proportion by which the phase-shifted sound is combined with the direct sound.

Delay

Left Time (Delay Time Left)

Adjusts the delay time from the original sound until the left delay sound is heard.

Right Time (Delay Time Right)

Adjusts the delay time from the direct sound until the right delay sound is heard.

Feedback (Delay Feedback Level)

Adjusts the proportion (%) of the delay sound that is fed back into the delay input.

HF Damp

Adjusts the frequency above which sound fed back to the effect will be cut. If you do not want to damp the high frequencies, set this parameter to BYPASS.

Balance (Delay Balance) #

Adjusts the volume balance between the direct sound and the delay sound.

Output**Level (Output Level)**

Adjusts the output level.

*1 .. In Realtime Control, the selected pitch is controlled with these parameters.

74: RHODES MULTI

Rhodes Multi provides Enhancer (EH), Phaser (PH), Chorus or Flanger (CF), and Tremolo or Pan (TP) effects connected in series.

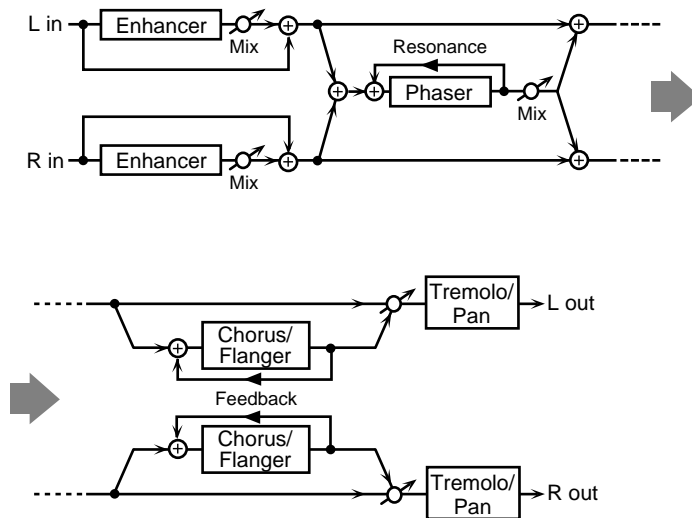

Sequence

Enhancer (Enhancer Switch)

Turns the Enhancer on/off.

Phaser (Phaser Switch)

Turns the Phaser on/off.

CF Sw (CF Switch)

Turns the chorus/flanger on/off.

TP Sw (TP Switch)

Turns tremolo or pan on/off.

Enhancer

Sens (Enhancer Sens)

Adjusts the sensitivity of the enhancer.

Mix Level (Enhancer Mix Level)

Adjusts the proportion by which the overtones generated by the enhancer are combined with the direct sound.

Phaser

Mode (Phaser Mode)

Selects the number of stages in the phaser.

Manual (Phaser Manual)

Sets the center frequency at which the phaser sound will be modulated.

Mix Level (Phaser Mix)

Adjusts the proportion by which the phase-shifted sound is combined with the direct sound.

Rate (Phaser Rate)

Specifies the frequency of modulation.

Depth (Phaser Depth)

Adjusts the depth of modulation.

Resonance (Phaser Resonance)

Adjusts the emphasis for the region around the center frequency specified by the PH Man parameter.

Chorus/Flanger**Type**

Selects either Chorus or Flanger.

Rate

Specifies the rate of modulation.

Depth

Specifies the depth of modulation.

Feedback (Feedback Level)

Adjusts the proportion (%) of the flanger sound that is fed back into the effect. Negative (-) settings will invert the phase.

PreDly (Pre Delay)

Adjusts the time from the direct sound until when the chorus or flanger sound is heard.

Balance #

Adjusts the volume balance between the direct sound and the chorus/flanger sound.

Type (Filter Type)

Selects the type of filter.

OFF: No filter is used.

LPF: The frequency region above the Cutoff Freq setting will be cut.

HPF: The frequency region below the Cutoff Freq setting will be cut.

Cutoff (Cutoff Frequency)

Sets the cutoff frequency when a specific frequency band is cut off by a filter.

Tremolo/Pan**Type**

Selects either Tremolo or Pan.

ModWave (Modulation Wave)

Selects the way in which tremolo or pan will be modulated.

Tri:The sound will be modulated like a triangle wave.

Sqr:The sound will be modulated like a square wave.

Sin:The sound will be modulated like a sine wave.

Saw1,2:The sound will be modulated like a sawtooth wave.

The teeth in **SAW1** and **SAW2** point at opposite directions.

Rate (Modulation Rate) #

Specifies the rate of modulation.

Depth (Modulation Depth) #

Specifies the depth of modulation.

Output**Level (Output Level)**

Adjusts the output level.

75: JD MULTI

This allows the Distortion (DS), Phaser (PH), Spectrum (SP), and Enhancer (EH) effects to be connected in series in any desired order.

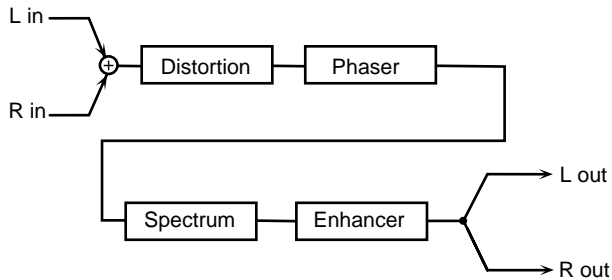

SEQUENCE

Sequence

Rearrange the order of effects (Distortion, Phaser, Spectrum, Enhancer).

Distortion

Switch (Distortion Switch)

Turns the Distortion on/off.

Type (Distortion Type)

Specifies the type of the distortion.

MELLOW DRIVE: A soft, mellow distortion; somewhat dark sounding.

OVERDRIVE: The classic sound of an overdriven tube amp.

CRY DRIVE: Distortion with a high-frequency boost.

MELLOW DIST: Sounds like the distortion you'd get from a really big amp.

LIGHT DIST: A distortion with an intense, brilliant feel.

FAT DIST: Boosted lows and highs gives this one a thick, fat sound.

FUZZ DIST: Like FAT DIST, but with even more distortion.

Drive (Distortion Drive)

Adjusts the degree of distortion.

Level (Distortion Level)

Sets the distortion output level.

Phaser

Switch (Phaser Switch)

Turns the Phaser on/off.

Manual (Phaser Manual)

Specifies the center frequency at which the sound is modulated.

Mix Level

Specifies the volume of the phase-shifted sound, relative to the direct sound.

Rate (Phaser Rate)

Specifies the frequency of modulation.

Depth (Phaser Depth)

Adjusts the depth of modulation.

Resonance (Phaser Resonance) #

Adjusts the amount of feedback for the phaser. Higher settings will give the sound a stronger character.

Spectrum**Switch (Spectrum Switch)**

Turns the Spectrum on/off.

Band Width

Specifies the range of all bands in which the level will be modified.

250Hz (250Hz Gain)

Specifies the gain (amount of boost or cut) at 250 Hz.

500Hz (500Hz Gain)

Specifies the gain (amount of boost or cut) at 500 Hz.

1000Hz (1000Hz Gain)

Specifies the gain (amount of boost or cut) at 1000 Hz.

2000Hz (2000Hz Gain)

Specifies the gain (amount of boost or cut) at 2000 Hz.

4000Hz (4000Hz Gain)

Specifies the gain (amount of boost or cut) at 4000 Hz.

8000Hz (8000Hz Gain)

Specifies the gain (amount of boost or cut) at 8000 Hz.

Enhancer**Switch (Enhancer Switch)**

Turns the Enhancer on/off.

Sens (Enhancer Sens)

Adjusts the sensitivity of the enhancer.

Mix Level #

Determines the proportion at which the overtones generated by the enhancer will be mixed with the original sound.

Output**Level (Output Level)**

Adjusts the output level.

Pan (Output Pan)

Adjusts the stereo location of the output sound.

76: STEREO LOFI COMPRESS

This is a stereo Lo-Fi compress. This is an effect that intentionally degrades the sound quality.

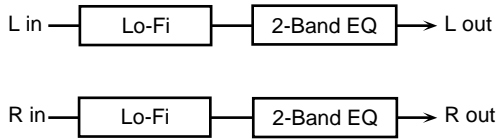

Lo-Fi

Type (LoFi Type)

Degrades the sound quality. The sound quality will become poorer as this value is increased.

Pre Filter

Type

Specifies the type of filter that will be applied before the sound passes through the Lo-Fi effect.

Post Filter 1

Type

Specifies the type of filter that will be applied after the sound passes through the Lo-Fi effect.

Post Filter 2

Type

OFF: A post filter 2 will not be used.

LPF: The frequency region above the Cutoff Freq setting will be cut.

HPF: The frequency region below the Cutoff Freq setting will be cut.

Cutoff (Cutoff Frequency)

Sets the cutoff frequency when a specific frequency band is cut off by a filter.

EQ Gain

Low (Low Gain)

Adjusts the gain of the low frequency range.

Positive (+) settings will emphasize (boost) the low-frequency range.

High (High Gain)

Adjusts the gain of the high frequency range.

Positive (+) settings will emphasize (boost) the high-frequency range.

Balance

Balance

Sets the volume balance between the direct sound and the effect sound.

With a setting of D100:0W only the direct sound will be output, and with a setting of D0:100W only the effect sound will be output.

Output

Level (Output Level)

Adjusts the output level.

77: STEREO LO-FI NOISE

This is a stereo Lo-Fi noise. In addition to a Lo-Fi effect, this effect also generates various types of noise such as radio noise and disc noise.

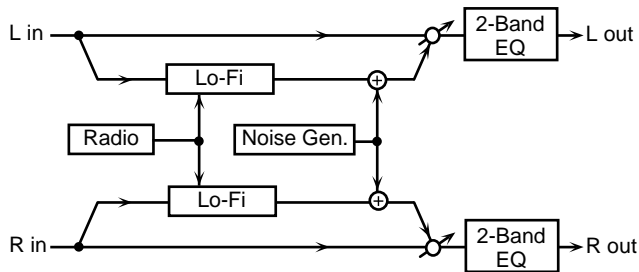

Lo-Fi

Type

Degrades the sound quality. The sound quality will become poorer as this value is increased.

Hum

Type (Hum Noise Type)

Selects the type of hum noise.

LPF (Hum Noise LPF)

Specifies the cutoff frequency of the low pass filter that is applied to the hum noise.

Level (Hum Noise Level)

Specifies the volume of the hum noise.

Post Filter

Type (Post Filter Type)

OFF: No filter is used.

LPF: Frequencies higher than the selected cutoff frequency value are eliminated.

HPF: Frequencies lower than the selected cutoff frequency value are eliminated.

Cutoff (Post Filter Cutoff Frequency)

Sets the cutoff frequency when a specific frequency band is cut off by a filter.

Disc Noise

Disc Noise Type

Selects the type of record noise. The frequency at which the noise is heard will depend on the selected type.

Disc Noise LPF

Specifies the cutoff frequency of the low pass filter that is applied to the record noise.

Disc Noise Level

Specifies the volume of the record noise.

Radio Noise

Detune (Radio Detune)

Simulates the tuning noise of a radio. As this value is raised, the tuning will drift further.

Level (Radio Noise Level)

Specifies the volume of the radio noise.

Noise

Noise Type

Selects either white noise or pink noise.

LPF (White/Pink Noise LPF)

Specifies the cutoff frequency of the low pass filter that is applied to the white noise or pink noise.

Level (White/Pink Noise Level)

Specifies the volume of the white noise or pink noise.

EQ Gain

Low (Low Gain)

Adjusts the gain of the low frequency range.

Positive (+) settings will emphasize (boost) the low-frequency range.

High (High Gain)

Adjusts the gain of the high frequency range.

Positive (+) settings will emphasize (boost) the high-frequency range.

Balance

Balance

Sets the volume balance between the direct sound and the effect sound.

With a setting of D100:0W only the direct sound will be output, and with a setting of D0:100W the effect sound will be output.

Output

Level (Output Level)

Adjusts the output level.

78: GUITAR AMP SIMULATOR

This is an effect that simulates an amp.

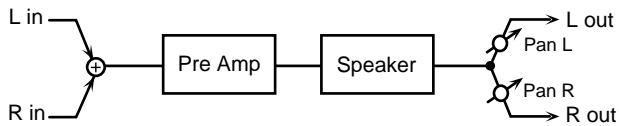

Amp Simulator

Switch (Pre Amp Switch)

Turns the amp switch on/off.

Type (Pre Amp Type)

Selects the type of guitar amp.

Amp Level

Volume (Pre Amp Volume)

Adjusts the volume and the amount of distortion of the amp.

Master (Pre Amp Master Volume)

Adjusts the volume of the entire pre-amp.

Gain (Pre Amp Gain)

Selects the degree of pre-amp distortion between three levels of Low, Middle and High.

Amp Tone

Presence (Pre Amp Presence)

Adjusts the tone for the ultra high frequency range. Normally the range will be 0-127, but when "Match Drive" is selected for the Pre-amp Type parameter, the range will be -127-0.

Bright (Pre Amp Brightness)

Turning this "On" will produce a sharper and brighter sound. This parameter can be set if the Pre-amp Type is set to "JC-120," "Clean Twin," or "BG Lead."

Bass (Pre Amp Bass)

Sets the bass sound quality.

Middle (Pre Amp Middle)

Adjusts the tone of the mid range. If "MAch Drive" is selected for the Pre-amp type parameter, this parameter cannot be set.

Treble (Pre Amp Treble)

Sets the treble sound quality.

Speaker

Switch (Speaker Switch)

Determines whether the signal passes through the speaker (ON), or not (OFF).

Speaker Type

Selects the type of speaker. The specifications of each type are as follows. The “Speaker” column lists the diameter of the speakers (in inches) along with the number of speakers there are.

Type	Cabinet	Speaker	Microphone
SMALL 1	small open-back enclosure	10	dynamic
SMALL 2	small open-back enclosure	10	dynamic
MIDDLE	open back enclosure	12 x 1	dynamic
JC-120	open back enclosure	12 x 2	dynamic
BUILT IN 1	open back enclosure	12 x 2	dynamic
BUILT IN 2	open back enclosure	12 x 2	condenser
BUILT IN 3	open back enclosure	12 x 2	condenser
BUILT IN 4	open back enclosure	12 x 2	condenser
BUILT IN 5	open back enclosure	12 x 2	condenser
BG STACK 1	sealed enclosure	12 x 2	condenser
BG STACK 2	large sealed enclosure	12 x 2	condenser
MS STACK 1	large sealed enclosure	12 x 4	condenser
MS STACK 2	large sealed enclosure	12 x 4	condenser
METAL STACK	large double stack	12 x 4	condenser
2-STACK	large double stack	12 x 4	condenser
3-STACK	large triple stack	12 x 4	condenser

Mic

Setting

Specifies the location of the mic that is recording the sound of the speaker. This can be adjusted in three steps, with the mic becoming more distant in the order of 1, 2, and 3.

Level (Mic Level)

Adjusts the volume of the microphone.

Direct (Direct Level)

Specifies the volume of the direct sound.

Output

Level (Output Level)

Adjusts the output level.

Pan (Output Pan)

Specifies the stereo location of the output sound. L64 is far left, 0 is center, and 63R is far right.

79: STEREO OVERDRIVE

This is a stereo overdrive.

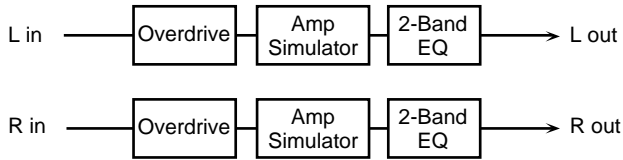

Overdrive

Drive

Adjusts the degree of distortion. The volume will change together with the degree of distortion.

Tone

Specifies the sound quality of the Overdrive effect.

Amp Simulator

Switch (Amp Simulator Switch)

Turns the Amp Simulator switch on/off.

Type (Amp Simulator Type)

Selects the type of guitar amp.

SMALL: small amp

BUILT-IN: single-unit type amp

2-STACK: large double stack amp

3-STACK: large triple stack amp

EQ Gain

Low (Low Gain)

Adjusts the gain of the low frequency range.

Positive (+) settings will emphasize (boost) the low-frequency range.

High (High Gain)

Adjusts the gain of the high frequency range.

Positive (+) settings will emphasize (boost) the high-frequency range.

Output

Level (Output Level)

Adjusts the output level.

You can use the Output Level setting to even out the volume difference between the sound with and without Overdrive.

80: STEREO DISTORTION

This is a stereo distortion.

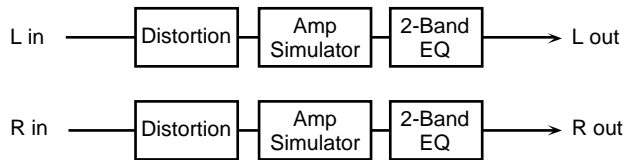

Distortion

Drive

Adjusts the degree of distortion. The volume will change together with the degree of distortion.

Tone

Adjusts the sound quality of the Distortion effect.

Amp Simulator

Switch (Amp Simulator Switch)

Turns the Amp Simulator switch on/off.

Type (Amp Simulator Type)

Selects the type of guitar amp.

SMALL: small amp

BUILT-IN: single-unit type amp

2-STACK: large double stack amp

3-STACK: large triple stack amp

EQ Gain

Low (Low Gain)

Adjusts the gain of the low frequency range.

Positive (+) settings will emphasize (boost) the low-frequency range.

High (High Gain)

Adjusts the gain of the high frequency range.

Positive (+) settings will emphasize (boost) the high-frequency range.

Output

Level (Output Level)

Adjusts the output level.

81: GUITAR MULTI A

Guitar Multi 1 connects Compressor (Cmp), Overdrive or Distortion (ODDS), Amp Simulator (Amp), Delay (Dly), and Chorus or Flanger (CF) effects in series.

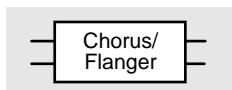
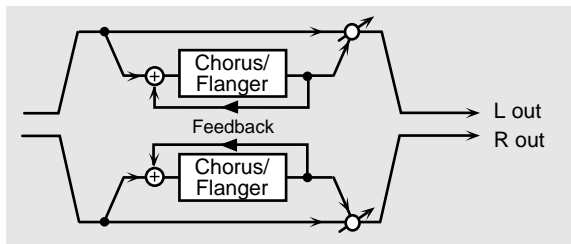
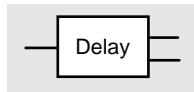
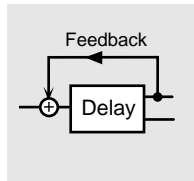
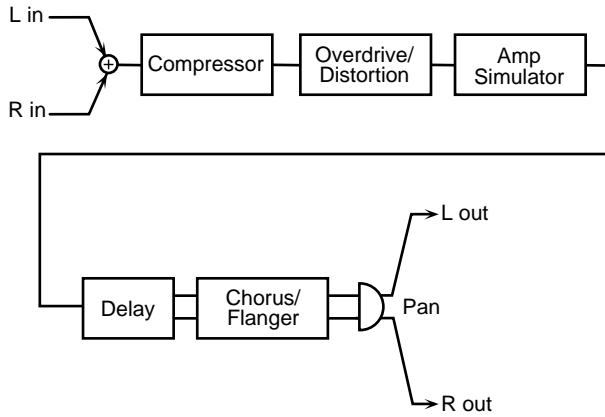

* In this section, the Delay and Chorus/Flanger are depicted in diagrams. When these same effects are discussed later, these diagrams are used.

Sequence

Comp (Compressor Switch)

Turns the Compressor on/off.

OD/Dist (Overdrive/Distortion Switch)

Turns the Overdrive/Distortion on/off.

Amp Sim (Amp simulator Switch)

Turns the Compressor on/off.

Delay (Delay Switch)

Turns the Delay on/off.

Cho/Flg (Chorus/Flanger Switch)

Turns the Chorus/Flanger on/off.

Compressor

Attack (Compressor Attack)

Specifies the duration of the attack when sound is input.

Sustain (Compressor Sustain)

Specifies the time over which low-level sounds will be boosted to reach the specified volume. Increasing the value will shorten the time. When the value is modified, the level will also change.

Level (Compressor Level) #

Sets the volume of the compressor sound.

Overdrive/Distortion

Type

Selects either Overdrive or Distortion.

Drive #

Adjusts the degree of distortion. The volume will change together with the degree of distortion.

Tone (Overdrive/Distortion Tone)

Adjusts the sound quality of the Overdrive/Distortion effect.

Level

Adjusts the Overdrive/Distortion output level.

Amp Simulator

Amp Type (Amp Simulator Type)

Selects the type of guitar amp.

Small:small amp

Bltn:built-in type amp

2-Stk:large double stack amp

3-Stk:large triple stack amp

Delay

Left Time (Delay Time Left)

Adjust the delay time from the original sound until the left delay sound is heard.

Right Time (Delay Time Right)

Adjust the delay time from the direct sound until the right delay sound is heard.

Feedback (Delay Feedback Level)

Adjusts the proportion (%) of the delay sound that is fed back into the delay input.

HF Damp

Adjusts the frequency above which sound fed back to the effect will be cut. If you do not want to damp the high frequencies, set this parameter to BYPASS.

Balance (Delay Balance) #

Adjusts the volume balance between the direct sound and the delay sound.

Chorus/Flanger

Type

Selects either Chorus or Flanger.

Rate

Specifies the rate of modulation.

Depth

Specifies the depth of modulation.

Feedback (CF Feedback)

Adjusts the proportion (%) of the flanger sound that is fed back into the effect. Negative (-) settings will invert the phase.

Pre Delay (Chorus/Flanger Pre Delay Time)

Adjusts the delay time from the direct sound until when the chorus sound is heard.

Balance #

Adjusts the volume balance between the direct sound and the chorus/flanger sound.

Filter

Type

Selects the type of filter.

OFF: No filter is used.

LPF: The frequency region above the Cutoff Freq setting will be cut.

HPF: The frequency region below the Cutoff Freq setting will be cut.

Cutoff (Cutoff Frequency)

Sets the cutoff frequency when a specific frequency band is cut off by a filter.

Output

Level (Output Level)

Adjusts the output level.

Pan (Output Pan) #

Adjusts the stereo location of the output sound.

82: GUITAR MULTI B

Guitar Multi 2 provides Compressor (Cmp), Overdrive or Distortion (ODDS), Amp Simulator (Amp), Equalizer (EQ), and Chorus or Flanger (CF) effects connected in series.

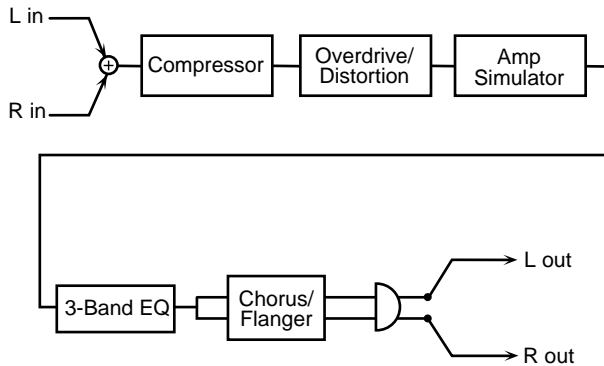

Sequence

Comp (Compressor Switch)

Turns the Compressor on/off.

OD/Dist (OD/Dist Switch)

Turns Overdrive or Distortion on/off.

Amp Sim (Amp Simulator Switch)

Turns the Amp Simulator on/off.

3 Band EQ (3 Band EQ Switch)

Turns the equalizer on/off.

Cho/Flg (Chorus/Flanger Switch)

Turns the chorus/flanger on/off.

Compressor

Attack (Compressor Attack)

Specifies the duration of the attack when sound is input.

Sustain (Compressor Sustain)

Specifies the time over which low-level sounds will be boosted to reach the specified volume. Increasing the value will shorten the time. When the value is modified, the level will also change.

Level (Compressor Level)

Sets the volume of the compressor sound.

Overdrive/Distortion

Type

Selects either Overdrive or Distortion.

Drive

Adjusts the degree of distortion. The volume will change together with the degree of distortion.

Tone (Overdrive/Distortion Tone)

Adjusts the sound quality of the Overdrive/Distortion effect.

Level

Sets the volume of the overdrive sound.

Amp Simulator

Type (Amp Simulator Type)

Selects the type of guitar amp.

Small:small amp

Bltn:built-in type amp

2-Stk:large double stack amp

3-Stk:large triple stack amp

EQ Gain

Low (EQ Low Gain)

Adjusts the low-range gain of the equalizer.

Mid (EQ Mid Gain)

Adjusts the gain of the area specified by the EQ M Fq parameter and the EQ M Q parameter.

High (EQ High Gain)

Adjusts the high-range gain of the equalizer.

Mid

Mid (EQ Mid Frequency)

Sets the center frequency for the equalizer mid-range.

Mid Q (EQ Mid Q)

Adjusts the width of the area centered at the EQ M Fq setting in which the gain will be affected. Higher values of Q will result in a narrower area being affected.

Chorus/Flanger

Type

Selects either Chorus or Flanger.

Rate

Sets the modulation speed for the chorus or flanger.

Depth

Sets the modulation depth for the chorus or flanger.

Feedback

Adjusts the proportion (%) of the flanger sound that is fed back into the effect. Negative (-) settings will invert the phase.

Pre Delay (Chorus/Flanger Pre Delay Time)

Adjusts the delay time from the direct sound until when the chorus sound is heard.

Balance

Adjusts the volume balance between the direct sound and the chorus/flanger sound.

Filter

Type (Filter Type)

Selects the type of filter.

OFF: No filter is used.

LPF: The frequency region above the Cutoff Freq setting will be cut.

HPF: The frequency region below the Cutoff Freq setting will be cut.

Cutoff (Cutoff Frequency)

Sets the cutoff frequency when a specific frequency band is cut off by a filter.

Output

Level (Output Level)

Adjusts the output level.

Pan (Output Pan)

Adjusts the stereo location of the output sound.

83: GUITAR MULTI C

Guitar Multi C connects Overdrive or Distortion (ODDS), Wah (Wah), Amp Simulator (Amp), Delay (Dly), and Chorus or Flanger (CF) effects in series.

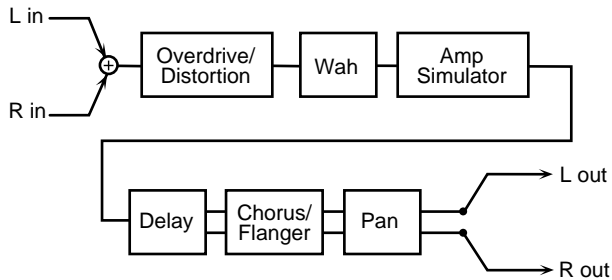

Sequence

Wah Sw (Wah Switch)

Turns the wah on/off.

Amp Sim (Amp Simulator Switch)

Turns the Amp Simulator on/off.

Wah (Wah Switch)

Turns the wah on/off.

Delay (Delay Switch)

Turns the Delay on/off.

Cho/Flg (Chorus/Flanger Switch)

Turns the wah on/off.

Overdrive/Distortion

Type

Selects either Overdrive or Distortion.

Drive

Adjusts the degree of distortion. The volume will change together with the degree of distortion.

Tone

Adjusts the sound quality of the Overdrive/Distortion effect.

Level

Adjusts the Overdrive (or Distortion) output level.

Wah

Filter Type (Wah Filter Type)

Selects the filter type.

LPF: The wah effect will be applied over a wide frequency range.

BPF: The wah effect will be applied over a narrow frequency range.

Rate

Adjusts the frequency of the modulation.

Depth

Adjusts the depth of the modulation.

Sens

Specifies the sensitivity with which the filter will be affected.

Manual #

Sets the center frequency from which the effect is applied.

Peak

Adjusts the amount of the wah effect that will occur in the area of the center frequency. Lower settings will produce a wah effect in a broad area around the center frequency, and higher settings will produce a wah effect in a narrower area around the center frequency.

Amp Simulator

Type (Amp Simulator Type)

Selects the type of guitar amp.

Small:small amp

Bltn:built-in type amp

2-Stk:large double stack amp

3-Stk:large triple stack amp

Delay

Left Time (Delay Time Left)

Adjust the delay time from the original sound until the left delay sound is heard.

Right Time (Delay Time Right)

Adjust the delay time from the direct sound until the right delay sound is heard.

Feedback (Delay Feedback Level)

Adjusts the proportion (%) of the delay sound that is fed back into the delay input.

HF Damp

Adjusts the frequency above which sound fed back to the effect will be cut. If you do not want to damp the high frequencies, set this parameter to BYPASS.

Balance (Delay Balance) #

Adjusts the volume balance between the direct sound and the delay sound.

Chorus/Flanger

Type

Selects either Chorus or Flanger.

Rate

Sets the modulation speed for the chorus or flanger.

Depth

Sets the modulation depth for the chorus or flanger.

Feedback (CF Feedback)

Adjusts the proportion (%) of the flanger sound that is fed back into the effect. Negative (-) settings will invert the phase.

Pre Delay (Chorus/Flanger Pre Delay Time)

Adjusts the delay time from the direct sound until when the chorus sound is heard.

Balance #

Adjusts the volume balance between the direct sound and the chorus/flanger sound.

Filter

Type

Selects the type of filter.

OFF: No filter is used.

LPF: The frequency region above the Cutoff Freq setting will be cut.

HPF: The frequency region below the Cutoff Freq setting will be cut.

Cutoff (Cutoff Frequency)

Sets the cutoff frequency when a specific frequency band is cut off by a filter.

Output

Level (Output Level)

Adjusts the output level.

Pan (Output Pan)

Adjusts the stereo location of the output sound.

84: CLEAN GUITAR MULTI A

Clean Guitar Multi 1 connects Compressor (Cmp), Equalizer (EQ), Delay (Dly), and Chorus or Flanger (CF) effects in series.

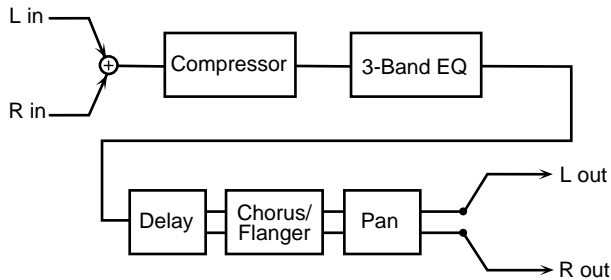

Sequence

Comp (Compressor Switch)

Turns the Compressor on/off.

3 Band EQ (3 Band EQ Switch)

Turns the equalizer on/off.

Delay (Delay Switch)

Turns the Delay on/off.

Cho/Flg (Chorus/Flanger Switch)

Turns the wah on/off.

Compressor

Attack (Compressor Attack)

Specifies the duration of the attack when sound is input.

Sustain (Compressor Sustain)

Specifies the time over which low-level sounds will be boosted to reach the specified volume. Increasing the value will shorten the time.

* *When the value is modified, the level will also change.*

Level (Compressor Level)

Sets the volume of the compressor sound.

EQ Gain

Low (EQ Low Gain)

Adjusts the low-range gain of the equalizer.

EQ M Gain (EQ Mid Gain)

Adjusts the gain of the area specified by the EQ M Fq parameter and the EQ M Q parameter.

High (EQ High Gain)

Adjusts the high-range gain of the equalizer.

Mid

Mid Freq (EQ Mid Frequency)

Sets the center frequency for the equalizer mid-range.

Mid Q (EQ Mid Q)

Adjusts the width of the area centered at the EQ M Fq setting in which the gain will be affected. Higher values of Q will result in a narrower area being affected.

Delay**Left Time (Delay Time Left)**

Adjust the delay time from the original sound until the left delay sound is heard.

Right Time (Delay Time Right)

Adjust the delay time from the direct sound until the right delay sound is heard.

Feedback (Delay Feedback Level)

Adjusts the proportion (%) of the delay sound that is fed back into the delay input.

HF Dump (Delay HF Dump)

Adjusts the frequency above which delayed sound fed back to the delay input will be cut. If you do not want the sound to be cut, select BYPASS.

Balance (Delay Balance) #

Adjusts the volume balance between the direct sound and the delay sound.

Chorus/Flanger**Type**

Selects either Chorus or Flanger.

Rate

Sets the modulation speed for the chorus or flanger.

Depth

Sets the modulation depth for the chorus or flanger.

Feedback (CF Feedback)

Adjusts the proportion (%) of the flanger sound that is fed back into the effect. Negative (-) settings will invert the phase.

Pre Dly (Chorus/Flanger Pre Delay Time)

Adjusts the delay time from the direct sound until when the chorus sound is heard.

Balance #

Adjusts the volume balance between the direct sound and the chorus/flanger sound.

Filter**Type**

Selects the type of filter.

OFF: No filter is used.

LPF: The frequency region above the Cutoff Freq setting will be cut.

HPF: The frequency region below the Cutoff Freq setting will be cut.

Cutoff (Cutoff Frequency)

Sets the cutoff frequency when a specific frequency band is cut off by a filter.

Output**Level (Output Level)**

Adjusts the output level.

Pan (Output Pan)

Adjusts the stereo location of the output sound.

85: CLEAN GUITAR MULTI B

Clean Guitar Multi 2 provides Auto-wah (AW), Equalizer (EQ), Delay (Dly), and Chorus or Flanger (CF) effects connected in series.

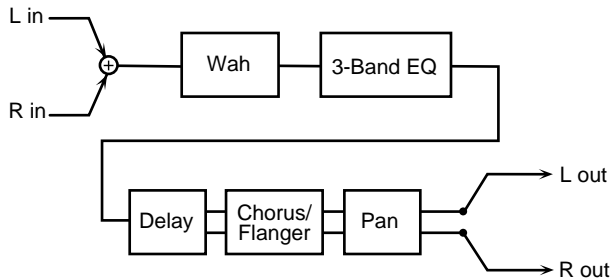

Sequence

Wah (Auto Wah Switch)

Turns the Auto Wah on/off.

3 Band EQ (3 Band EQ Switch)

Turns the 3 Band EQ on/off.

Delay (Delay Switch)

Turns the Delay on/off.

Cho/Flg Sw (Chorus/Flanger Switch)

Turns the Chorus/Flanger on/off.

Wah

Filter Type (Auto Wah Filter Type)

Selects the type of filter for the Auto-wah.

LPF: The wah effect will be applied over a wide frequency range.

BPF: The wah effect will be applied over a narrow frequency range.

Rate (Auto Wah Rate)

Sets the modulation speed of the Auto-wah.

Depth (Auto Wah Depth)

Sets the modulation depth of the Auto-wah.

Sens

Specifies the sensitivity with which the filter will be affected.

Manual (Auto Wah Manual)

Sets the center frequency at which the auto-wah effect will be produced.

Peak (Auto Wah Peak)

Adjusts the amount of the wah effect that will occur in the area of the center frequency. Lower settings will produce a wah effect in a broad area around the center frequency, and higher settings will produce a wah effect in a narrower area around the center frequency.

EQ Gain

Low (EQ Low Gain)

Adjusts the low-range gain of the equalizer.

Mid (EQ Mid Gain)

Adjusts the gain of the area specified by the EQ M Fq parameter and the EQ M Q parameter.

High (EQ High Gain)

Adjusts the high-range gain of the equalizer.

Mid**Mid Freq (EQ Mid Frequency)**

Sets the center frequency for the equalizer mid-range.

Mid Q (EQ Mid Q)

Adjusts the width of the area centered at the EQ M Fq setting in which the gain will be affected. Higher values of Q will result in a narrower area being affected.

Delay**Left Time (Delay Time Left)**

Adjust the delay time from the original sound until the left delay sound is heard.

Right Time (Delay Time Right)

Adjust the delay time from the direct sound until the right delay sound is heard.

Feedback (Delay Feedback Level)

Adjusts the proportion (%) of the delay sound that is fed back into the delay input.

HF Damp (Delay HF Damp)

Adjusts the frequency above which sound fed back to the effect will be cut. If you do not want to damp the high frequencies, set this parameter to BYPASS.

Balance (Delay Balance) #

Adjusts the volume balance between the direct sound and the delay sound.

Chorus/Flanger**Type**

Selects either Chorus or Flanger.

Rate

Sets the modulation speed for the chorus or flanger.

Depth

Sets the modulation depth for the chorus or flanger.

Feedback (CF Feedback)

Adjusts the proportion (%) of the flanger sound that is fed back into the effect. Negative (-) settings will invert the phase.

Pre Dly (Chorus/Flanger Pre Delay Time)

Adjusts the delay time from the direct sound until when the chorus sound is heard.

Balance #

Adjusts the volume balance between the direct sound and the chorus/flanger sound.

Filter

Type (Filter Type)

Selects the type of filter.

OFF: No filter is used.

LPF: The frequency region above the Cutoff Freq setting will be cut.

HPF: The frequency region below the Cutoff Freq setting will be cut.

Cutoff (Cutoff Frequency)

Sets the cutoff frequency when a specific frequency band is cut off by a filter.

Output

Level (Output Level)

Adjusts the output level.

Pan (Output Pan) #

Adjusts the stereo location of the output sound.

86: BASS MULTI

Bass Multi provides Compressor (Comp), Overdrive or Distortion (OD/Dist), Equalizer (3 Band EQ), and Chorus or Flanger (Cho/Flg) effects connected in series.

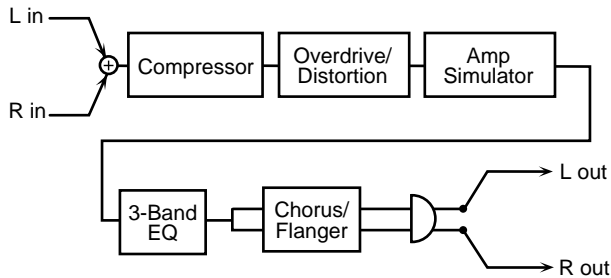

Sequence

Comp (Compressor Switch)

Turns the Compressor on/off.

OD/Dist (Overdrive or Distortion Switch)

Turns the Overdrive or Distortion on/off.

Amp Sim (Amp Simulator)

Turns the Amp Simulator on/off.

3 Band EQ (3 Band EQ Switch)

Turns the 3 Band EQ on/off.

Cho/Flg (Chorus/Flanger Switch)

Turns the Chorus/Flanger on/off.

Compressor

Attack (Compressor Attack)

Specifies the duration of the attack when sound is input.

Sustain (Compressor Sustain)

Specifies the time over which low-level sounds will be boosted to reach the specified volume. Increasing the value will shorten the time.

* *When the value is modified, the level will also change.*

Level (Compressor Level)

Sets the volume of the compressor sound.

Overdrive/Distortion

Type

Selects either Overdrive or Distortion.

Drive

Adjusts the degree of distortion. The volume will change together with the degree of distortion.

Level (Overdrive/Distortion Level)

Sets the volume of the Overdrive/Distortion sound.

Amp Simulator

Type (Amp Simulator Type)

Selects the type of bass amp.

Small:small amp

Bltn:built-in type amp

2-Stk:large double stack amp

3 Band EQ

Low (EQ Low Gain)

Adjusts the low-range gain of the equalizer.

Mid (EQ Mid Gain)

Adjusts the gain of the area specified by the EQ M Fq parameter and the EQ M Q parameter.

High (EQ High Gain)

Adjusts the high-range gain of the equalizer.

Mid

Mid Freq (EQ Mid Frequency)

Sets the center frequency for the equalizer mid-range.

Mid Q (EQ Mid Q)

Adjusts the width of the area centered at the EQ M Fq setting in which the gain will be affected. Higher values of Q will result in a narrower area being affected.

Chorus/Flanger

Type

Selects either Chorus or Flanger.

Rate

Sets the modulation speed for the chorus or flanger.

Depth

Sets the modulation depth for the chorus or flanger.

Feedback (Feedback Level)

Adjusts the proportion (%) of the flanger sound that is fed back into the effect. Negative (-) settings will invert the phase.

Pre Dly (Chorus/Flanger Pre Delay Time)

Adjusts the delay time from the direct sound until when the chorus sound is heard.

Balance

Adjusts the volume balance between the direct sound and the chorus/flanger sound.

Filter

Type

Selects the type of filter.

OFF: No filter is used.

LPF: The frequency region above the Cutoff Freq setting will be cut.

HPF: The frequency region below the Cutoff Freq setting will be cut.

Cutoff (Cutoff Frequency)

Sets the cutoff frequency when a specific frequency band is cut off by a filter.

Output

Level (Output Level)

Adjusts the output level.

Pan (Output Pan) #

Adjusts the stereo location of the output sound.

87: ISOLATOR 2

This adds a filter to the ISOLATOR effect. Isolator is an equalizer which cuts the volume greatly, allowing you to add a special effect to the sound by cutting the volume in varying ranges.

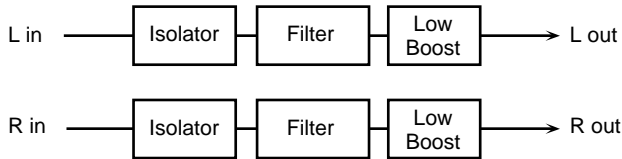

Boost/Cut

Low (Level Low) #

Mid (Level Middle) #

High (Level High) #

These boost and cut the High, Middle, and Low frequency ranges. At -60 dB, the sound becomes inaudible. 0 dB is equivalent to the input level of the sound.

Anti Phase Low

Anti Phase Low Sw (Anti Phase Low Switch)

Anti Phase Low Level

Anti Phase Mid

Switch (Anti Phase Middle Switch)

Level (Anti Phase Middle Level)

This turns the Anti-Phase function on and off and sets the level settings for the Middle and Low frequency ranges.

When turned on, the phases of opposite stereo channels are reversed and then added. Adjusting these levels for certain frequencies allows you to lend emphasis to specific parts. (This is effective only for stereo sources.)

Post Filter

Switch (Filter Switch)

Turns the filter on/off.

Type (Filter Type)

Selects the type of filter.

LPF: Passes frequencies below the cutoff frequency.

BPF: Passes frequencies near the cutoff frequency.

HPF: Passes frequencies above the cutoff frequency.

NOTCH: Passes frequencies other than those near the cutoff frequency.

Cutoff (Filter Cutoff Frequency)

Sets the filter's cutoff frequency. The closer to zero it is set, the lower the cutoff frequency becomes; set it closer to 127, and the cutoff frequency becomes higher.

Resonance (Filter Resonance)

Sets the filter's resonance level. Raising the setting increases resonance near the cutoff frequency, producing a uniquely characteristic sound.

Slope (Filter Slope)

Sets the filter's attenuation slope (-24 dB per octave: steep; -12 dB per octave: gentle).

Gain (Filter Gain)

Compensates for the volume dropped in the cut frequency range with some filters. The level of compensation increases as the value is increased, and raise the volume.

Low Boost**Switch (Low Booster Switch)**

Specifies whether Low Booster will be used (ON), or not (OFF). This emphasizes the bottom to create a heavy bass sound.

Level (Low Boost Level)

Increasing this value gives you a heavier low end. (Depending on the Isolator and filter settings this effect may be hard to distinguish.)

Output**Level (Output Level)**

Adjusts the output level.

88: STEREO SPECTRUM

This is a stereo spectrum. Spectrum is a type of filter which modifies the timbre by boosting or cutting the level at specific frequencies.

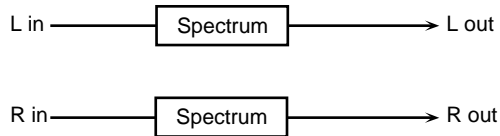

Band Gain

250Hz (250Hz Gain)

Specifies the gain (amount of boost or cut) at 250 Hz.

500Hz (500Hz Gain)

Specifies the gain (amount of boost or cut) at 500 Hz.

1000Hz (1000Hz Gain)

Specifies the gain (amount of boost or cut) at 1000 Hz.

1250 Hz (1250 Hz Gain)

Specifies the gain (amount of boost or cut) at 1250 Hz.

2000 Hz (2000 Hz Gain)

Specifies the gain (amount of boost or cut) at 2000 Hz.

3150 Hz (3150 Hz Gain)

Specifies the gain (amount of boost or cut) at 3150 Hz.

4000 Hz (4000 Hz Gain)

Specifies the gain (amount of boost or cut) at 4000 Hz.

8000 Hz (8000 Hz Gain)

Specifies the gain (amount of boost or cut) at 8000 Hz.

Band Width

Q

Specifies the range of all bands in which the level will be modified.

Output

Level (Output Level) #

Adjusts the output level.

89: 3D AUTO SPIN

The 3D Auto Spin effect rotates the location of the sound.

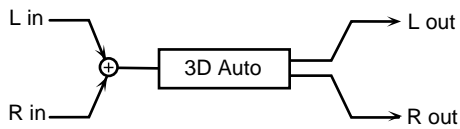

Auto Spin

Azimuth

Sets the location at which the sound will stop when rotation is stopped. A setting of “0” positions the sound in the center.

Speed

Sets the speed of rotation.

Clockwise

Sets the direction of rotation. A setting of “-” produces counterclockwise rotation, while at “+” it will be clockwise.

Turn

Stops or starts the rotation. When this is turned On, the sound will rotate. When turned Off, rotation will stop at the location specified by Azimuth.

Output

Out (Output Mode)

Specifies the method that will be used to reproduce the sound that is output to the OUTPUT jacks. The optimal 3D effect will be achieved if you select SPEAKER when using speakers, or PHONES when using headphones.

Level (Output Level)

Adjusts the output level.

90: 3D MANUAL

This places the 3D effect at a desired location.

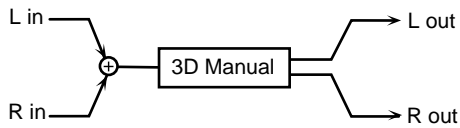

Auto Spin

Azimuth

Specifies the location. A setting of "0" positions the sound in the center.

Output

Out (Output Mode)

Specifies the method that will be used to reproduce the sound that is output to the OUTPUT jacks. The optimal 3D effect will be achieved if you select SPEAKER when using speakers, or PHONES when using headphones.

Level (Output Level)

Adjusts the output level.

When Using 3D Effects

The following 3D effects utilize RSS (Roland Sound Space) technology to create a spaciousness that cannot be produced by delay, reverb, chorus, etc.

- 48: 3D DELAY
- 60: 3D CHORUS
- 61: 3D FLANGER
- 70: 3D DELAY 2
- 89: 3D AUTO SPIN
- 90: 3D MANUAL

When using these effects, we recommend that you place your speakers as follows. Also, make sure that the speakers are at a sufficient distance from the walls on either side.

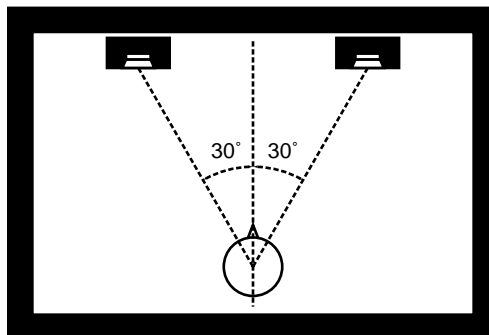

If the left and right speakers are too far apart, or if there is too much reverberation, the full 3D effect may not appear.

Each of these effects has an Out (Output Mode) parameter. If the sound from the OUTPUT jacks is to be heard through speakers, set this parameter to "Speaker." If the sound is to be heard through headphones, set it to "Phones." This will ensure that the optimal 3D effect will be heard. If this parameter is not set correctly, the full 3D effect may not appear