

## R-BUS INTERFACE CARD

# RPC-1

## Owner's Manual

Before using this unit, carefully read the sections entitled: "USING THE UNIT SAFELY" and "IMPORTANT NOTES" (Owner's manual p. 2; Owner's manual p. 3). These sections provide important information concerning the proper operation of the unit. Additionally, in order to feel assured that you have gained a good grasp of every feature provided by your new unit, the Owner's manual should be read in its entirety. The manual should be saved and kept on hand as a convenient reference.

Copyright © 2001 ROLAND CORPORATION

All rights reserved. No part of this publication may be reproduced in any form without the written permission of ROLAND CORPORATION.

Roland Web site <http://www.roland.co.jp/>



# USING THE UNIT SAFELY

## INSTRUCTIONS FOR THE PREVENTION OF FIRE, ELECTRIC SHOCK, OR INJURY TO PERSONS

### About ⚠ WARNING and ⚠ CAUTION Notices

<b>⚠ WARNING</b>	Used for instructions intended to alert the user to the risk of death or severe injury should the unit be used improperly.
<b>⚠ CAUTION</b>	Used for instructions intended to alert the user to the risk of injury or material damage should the unit be used improperly. * Material damage refers to damage or other adverse effects caused with respect to the home and all its furnishings, as well to domestic animals or pets.

### About the Symbols

	The ⚠ symbol alerts the user to important instructions or warnings. The specific meaning of the symbol is determined by the design contained within the triangle. In the case of the symbol at left, it is used for general cautions, warnings, or alerts to danger.
	The ⚡ symbol alerts the user to items that must never be carried out (are forbidden). The specific thing that must not be done is indicated by the design contained within the circle. In the case of the symbol at left, it means that the unit must never be disassembled.
	The ⚡ symbol alerts the user to things that must be carried out. The specific thing that must be done is indicated by the design contained within the circle. In the case of the symbol at left, it means that the power-cord plug must be unplugged from the outlet.

### ALWAYS OBSERVE THE FOLLOWING



#### ⚠ WARNING

- Before using this unit, make sure to read the instructions below, and the Owner's Manual. 



---

- Do not open or perform any internal modifications on the unit. 

---

- Never use or store the unit in places that are:
  - Subject to temperature extremes (e.g., direct sunlight in an enclosed vehicle, near a heating duct, on top of heat-generating equipment); or are 
  - Damp (e.g., baths, washrooms, on wet floors); or are 
  - Humid; or are
  - Exposed to rain; or are
  - Dusty; or are
  - Subject to high levels of vibration.

---

- Do not allow any objects (e.g., flammable material, coins, pins); or liquids of any kind (water, soft drinks, etc.) to penetrate the unit.   



---

- In households with small children, an adult should provide supervision until the child is capable of following all the rules essential for the safe operation of the unit. 

---

- Protect the unit from strong impact. (Do not drop it!) 

#### ⚠ CAUTION

- Try to prevent cords and cables from becoming entangled. Also, all cords and cables should be placed so they are out of the reach of children. 

# IMPORTANT NOTES

In addition to the items listed under “USING THE UNIT SAFELY” on page 2, please read and observe the following:

## Placement

- Do not expose the unit to direct sunlight, place it near devices that radiate heat, leave it inside an enclosed vehicle, or otherwise subject it to temperature extremes. Excessive heat can deform or discolor the unit.
- To avoid possible breakdown, do not use the unit in a wet area, such as an area exposed to rain or other moisture.

## Additional Precautions

- Use a reasonable amount of care when using the unit’s buttons, sliders, or other controls; and when using its jacks and connectors. Rough handling can lead to malfunctions.
- When connecting / disconnecting all cables, grasp the connector itself—never pull on the cable. This way you will avoid causing shorts, or damage to the cable’s internal elements.
- To avoid disturbing your neighbors, try to keep the unit’s volume at reasonable levels (especially when it is late at night).

## Handling CD-ROMs

- Avoid touching or scratching the shiny underside (encoded surface) of the disc. Damaged or dirty CD-ROM discs may not be read properly. Keep your discs clean using a commercially available CD cleaner.

# Contents

USING THE UNIT SAFELY.....	2
IMPORTANT NOTES.....	3
<b>Before you begin.....</b>	<b>5</b>
Check the included items .....	5
Main features.....	5
<b>Names of things and what they do.....</b>	<b>6</b>
<b>Preparations for using the RPC-1 .....</b>	<b>7</b>
Minimum requirements .....	7
Installing the RPC-1 .....	7
Installing the RPC-1 driver (Windows).....	7
Installing the RPC-1 driver (Macintosh) .....	9
About the various RPC-1 drivers.....	10
<b>RPC-1 Control Panel.....</b>	<b>11</b>
Main functions of RPC-1 Control Panel.....	11
Signal flow .....	11
RPC-1 Control Panel .....	11
<b>Connections with other R-BUS devices .....</b>	<b>13</b>
Connections with R-BUS devices.....	13
Connections with the VM-3100Pro .....	13
Connections with the VM-7200/7100.....	14
Connections with the XV-5080 .....	15
Connections with the ADA-7000.....	15
Connections with the AE-7000 .....	15
Connections with the VSR-880 .....	16
Connections with the VS-2480.....	16
<b>Using multiple RPC-1 units.....</b>	<b>17</b>
Settings for using multiple RPC-1 units.....	17
Synchronizing multiple RPC-1 units .....	17
<b>Software settings .....</b>	<b>18</b>
Logic Audio settings .....	18
Cubase VST settings.....	18
Sonar settings (Windows) .....	18
<b>Troubleshooting.....</b>	<b>19</b>
<b>Main specifications .....</b>	<b>20</b>
<b>Information .....</b>	<b>22</b>

# Before you begin

## Check the included items

---

The following items are included with the RPC-1. Immediately after opening the package, please check that all items are included. If any items are missing, please contact the retailer from whom you purchased the RPC-1.

### ■ RPC-1

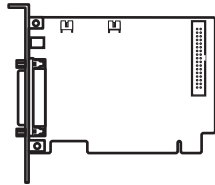

### ■ Drivers/Update CD-ROM

This contains driver software for using the RPC-1, and a system program updater that makes R-BUS devices compatible with the RPC-1.

### ■ RPC-1 Owner's Manual

This document.

### ■ R-BUS cable

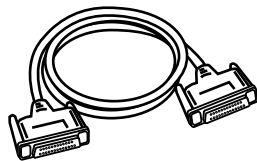

This cable is used to connect the RPC-1 to an R-BUS device.

### ■ Clock cable



This cable is used to synchronize multiple RPC-1 units. For details refer to "Clock In and Clock Out Connectors."

## Main features

---

### ■ Digital multi audio

Eight input and eight output channels of digital audio can be transmitted and received simultaneously (maximum 24 bit, 96 kHz).

### ■ MIDI

The RPC-1 provides 16 channels of MIDI IN/OUT on the R-BUS. This allows MTC synchronization with a connected R-BUS device.

### ■ Included drivers

- Windows 95/98/Me/NT4.0/2000 and Mac OS 8.6/9.0/9.1 are supported
- Windows MME, ASIO2.0, and Apple Sound Manager compatible drivers
- MIDI driver (OMS driver for the Macintosh)



In order to use the RPC-1's **MIDI** functionality on the **Macintosh**, you must install Opcode Corporation's **OMS 2.3.8**. Install it using the "**Drivers/Update**" **CD-ROM** included with the RPC-1. For details, refer to **p. 9 "Installing the RPC-1 driver (Macintosh)."**

# Names of things and what they do

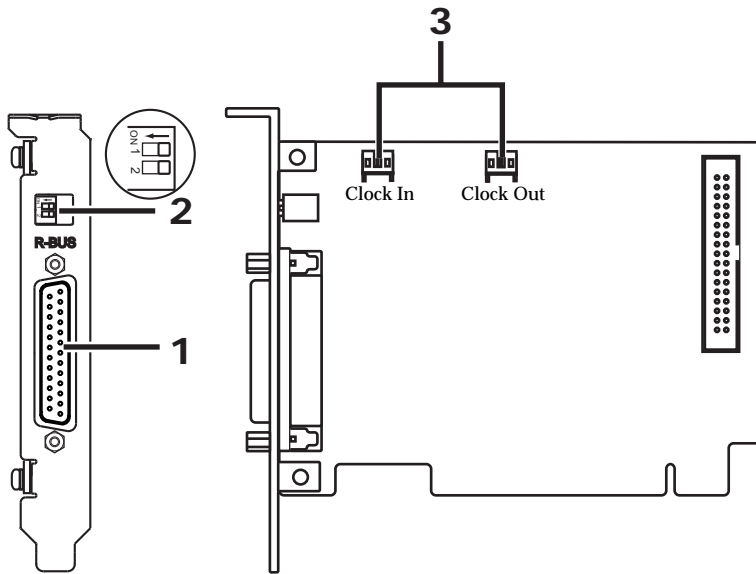

## 1. R-BUS (RMDB2) connector

Connect this to R-BUS devices. This connector carries multi-channel digital audio (8-IN, 8-OUT) in formats up to 24 bit and 96 kHz, as well as one set of MIDI IN/OUT signals.

## 2. DIP switches

The DIP switches are used to specify how the RPC-1 will transmit word clock data. Each switch has the following function.

Number	OFF	ON
SW1	Normal mode	VS-2480 mode (when RPC-1 is slave)
SW2	DIP switch function ON	DIP switch function OFF

Normally, you will leave these set at **SW1: OFF** and **SW2: OFF**.

In the following situations, set SW1: ON.

- When connected to the VS-2480 and using the RPC-1 as **slave**
- When connecting two RPC-1 units to each other (turn SW1 ON only for the slave unit)

## 3. Clock In, Clock Out connectors

Use these to synchronize multiple RPC-1 units. (For details on using multiple units, refer to p. 17 “Using multiple RPC-1 units.”)

To avoid the risk of damage to internal components that can be caused by static electricity, please carefully observe the following whenever you handle the board.

- Before you touch the board, always first grasp a metal object (such as a water pipe), so you are sure that any static electricity you might have been carrying has been discharged.
- When handling the board, grasp it only by the panel or the board’s edges. Avoid touching any of the electronic components or connectors.
- Before you connect any cables, make sure they do not carry a static electricity charge. Such charges can be transmitted, for example, if the other end of the cable has been in contact with a carpet (or other object) where there is a static electricity buildup.
- Save the bag in which the board was originally shipped, and put the board back into it whenever you need to store or transport it.



To prevent malfunction and/or damage to speakers or other devices, always turn down the volume, and turn off the power on all devices before making any connections.

# Preparations for using the RPC-1

## Minimum requirements

In order to install the RPC-1, you must have a computer that has a PCI slot and fulfills the following conditions.



The RPC-1 operates on a 5V PCI bus. It will not operate on a 3.3V PCI bus.

### Windows users

- A PC-compatible computer with **Windows 95/98/Me/NT4.0/2000** installed
  - **Pentium MMX 300 MHz or better** CPU (PentiumII 300 MHz or better is recommended\*)
  - **64 MB or more** RAM (128 MB or more is recommended)
- \* *Pentium III 450MHz with 128MB of RAM or better is recommended for 24bit-88.2/96kHz operation.*

### Macintosh users

- A Power Macintosh with **Mac OS 8.6 or later\*** installed (9.0 or later is recommended)
  - **Power PC G3** or better CPU (G3 300 MHz or better is recommended)
  - **96 MB or more** RAM (128 MB or more is recommended.)
- \* *MacOS X is not supported (will be supported in the near future).*

## Installing the RPC-1

Install the RPC-1 into the PCI slot of your computer. For details on installing a PCI card, refer to your computer's manual.

- Do not touch any of the printed circuit pathways or connection terminals.
- Never use excessive force when installing a circuit board. If it doesn't fit properly on the first attempt, remove the board and try again.
- When circuit board installation is complete, double-check your work.

1. Turn off the power of your computer, and unplug the power cable.
2. Remove the cover of your computer, and remove the cover of the PCI slot in which the RPC-1 will be installed. (The screw that held the cover in place will be used to fasten the RPC-1.)
3. Insert the RPC-1 into the PCI slot. Notice that the RPC-1 cannot be inserted if it is oriented in the wrong direction.
4. Fasten the RPC-1 using the screw that had fastened the PCI slot cover.
5. Re-attach the cover of your computer.

## Installing the RPC-1 driver (Windows)

### Windows95/98

1. When you start up your computer after installing the RPC-1, the RPC-1 will be detected automatically, and the "Add New Hardware wizard" will start up. Then click "Next."
2. Into your **CD-ROM drive**, insert the "Drivers/Update" CD-ROM that was included with the RPC-1.
3. Select "Search for the best driver for your device" and click "Next."
4. Check "Specify a location" and click "Browse," and select the **CD-ROM drive**(Roland\_rpc-1).
5. Select the "95\_98\_Me" folder under "DRIVERS" folder, and click "OK."
6. Click "Next" to begin the installation.
7. When the message of "Windows has finished installing the software you selected that your new hardware device requires" appears, click "Finish."
8. Windows will start up.

### Windows Me

1. When you start up your computer after installing the RPC-1, the RPC-1 will be detected automatically, and the "Add New Hardware wizard" will start up.
2. Into your **CD-ROM drive**, insert the "Drivers/Update" CD-ROM that was included with the RPC-1.
3. Check "Automatic search for a better driver" and click "Next."
4. Two "Roland RPC-1" drivers will be recognized. Select one of them located in "DRIVERS\95\_98\_Me\MA\_DELTA.INF" under **CD-ROM drive**.
5. Click "OK" to begin the installation.
6. When the message of "Roland RPC-1 : Windows has finished installing the software you selected that your new hardware device requires" appears, click "Finish."
7. Windows will start up.

## Preparations for using the RPC-1

### Windows 2000

1. Start up your computer after installing the RPC-1.
2. In order to install the RPC-1 driver, you must be logged onto the system as **Administrator**. For details, contact your system administrator.
3. The RPC-1 will be detected automatically, and the **"Found New Hardware Wizard"** will start up. Click **"Next."**
4. Check **"Search for a suitable driver for my device"** and click **"Next."**
5. The message of **"Insert the manufacturer's installation disk into the drive selected, and then click OK"** appears.
6. Into your **CD-ROM drive**, insert the **"Drivers/Update"** **CD-ROM** that was included with the RPC-1 and click **"OK."**
7. Specify the location of the driver information file. The RPC-1 driver file is located in **"CD-ROM drive(ROLAND\_ RPC-1) > DRIVERS folder > WDM folder."** Select **"RolandRPC-1.inf"** in the above folder and click **"Open."**
8. Click **"OK."**
9. When the message of **"Driver Files Search Results: The wizard has finished searching for driver files for your hardware device"** appears, click **"Next."**
10. Click **"Yes"** if the message of **"Digital signature Not Found....."** appears.
11. The installing will start up.
12. When the message **"Completing the Found New Hardware Wizard : Roland RPC-1"** appears, click **"Finish."**
13. Windows 2000 will start up.

### Windows XP

1. Start up your computer after installing the RPC-1.
2. In order to install the RPC-1 driver, you must be logged onto the system as **Administrator**. For details, contact your system **administrator**.
3. The RPC-1 will be detected automatically, and the **"Found New Hardware Wizard"** will start up.
4. Into your **CD-ROM drive**, insert the **"Drivers/Update"** **CD-ROM** that was included with the RPC-1.
5. Click **"Yes"** if the message of **"Digital signature Not Found....."** appears.
6. The installing will start up.
7. When the message **"Completing the Found New Hardware Wizard : Roland RPC-1"** appears, click **"Finish."**
8. Windows XP will start up.

### Windows NT4.0

1. In order to install the RPC-1 driver, you must be logged onto the system as **Administrator**. For details, contact your system administrator.
2. Into your **CD-ROM drive**, insert the **"Drivers/Update"** **CD-ROM** included with the RPC-1.
3. From the **"Start"** menu, select **"Settings,"** and open the **"Control Panel."**
4. Double-click **"Multimedia."**
5. Click **"Devices,"** and click **"Add."**
6. Select **"Unlisted or updated driver,"** and click **"OK."**
7. When the driver installation window appears, click **"Browse,"** and select the **CD-ROM drive**. Select the **"WINNT"** folder under **"DRIVERS"** folder, and click **"OK."**
8. Select **"Roland RPC-1 Interface Card"** in the **"Add unlisted or updated driver"** window. Click **"OK."**
9. When installation is finished, a message will ask you to restart the system. Click **"Restart Now"** to restart the system.



## Installing the RPC-1 driver (Macintosh)

### Mac OS 8.6 or later

1. Into your **CD-ROM drive**, insert the **"Drivers/Update"** **CD-ROM** included with the RPC-1. Then double-click the **CD-ROM icon** to open it.
2. If you wish to use the MIDI functionality of the RPC-1, install **"OMS 2.3.8."** (If OMS 2.3.8 is already installed, it is not necessary to re-install it.) Open the **"OMS 2.3.8"** folder, start up **"Install OMS 2.3.8,"** and perform the installation as directed by the installer. After Installation, you must **restart** your computer.
3. Open the **"RPC-1 Driver"** folder, and copy the **"Roland RPC-1 Driver"** file into the **"Extensions folder"** of the **"System folder."**
4. If you wish to use software that is compatible with the **ASIO driver**, copy the **"ASIO RPC-1"** file to the location specified by your software (in the case of **Logic Audio** or **Cubase VST**, the **"ASIO Drivers"** folder).
5. Copy the **"RPC-1 Control Panel"** file to your desktop or other desired location (you may place it anywhere).
6. Copy the **"RPC-1 OMS Driver"** file into the **"OMS Folder"** within the **"System folder."**
7. **Restart** your computer.

### NOTE

You must install **OMS 2.3.8** before installing the **"RPC-1 OMS driver."**

### OMS Setup (Macintosh)

1. Start up **"OMS Setup."** **"OMS Setup"** is placed into the **"OMS Applications"** folder in the **"Opcode"** folder.
2. When a dialog box with a message of **"Create a New Studio Setup"** appears, click **"OK."**
3. A dialog to specify the MIDI interface port will appear. Click **"Search."** Neither **Modem** nor **Printer** should be checked.
4. The device list will appear after searching. Click **"OK"** after making sure that **"RPC-1"** is included in the device list. If there is no list, make sure that the **"Roland RPC-1 driver"** or **"RPC-1 OMS driver"** was installed correctly.
5. Check **"RPC-1"** in the MIDI device list, then click **"OK."**
6. When a dialog to save the setup appears, enter a name and then save it.
7. A dialog box showing the setup documents will appear. Double click the keyboard icon with a **"?"** mark to start the setup for the equipment to be connected with the RPC-1.
8. Make sure that this setup is the **"current setup,"** then quit **"OMS setup."**

**"Current Setup"** means the currently active setup from the several setups available. The mark of **"◇"** is indicated in the title bar of the current setup. Select **"Make Current"** in the **File** menu to choose the current setup.

## Preparations for using the RPC-1

### About the various RPC-1 drivers

If the RPC-1 driver is installed, the following drivers can be used.

Refer to the manual for the software you are using, and use the most suitable drivers.

#### ASIO driver

**ASIO** (Audio Stream In/Out) is a driver format promoted by **Steinberg Corporation** for connecting audio software and audio hardware. ASIO supports both Windows and Macintosh platforms, and allows high-quality multi-channel input/output.

The RPC-1 comes with an **ASIO2.0** driver for **Windows (95/ 98/Me/2000)** and **Mac OS (8.6 or later)**.

\* *Name of the ASIO driver for Windows 95/98/Me is "M Audio Delta ASIO."*

For Macintosh, there are three version of the ASIO driver.

**ASIO2:** ASIO2.0 driver

**ASIO:** ASIO2.0 driver without software monitoring

**ASIOv3:** ASIO1 driver for *Digital Performer*.

#### EASI driver

**EASI** (Enhanced Audio Streaming Interface) is a driver format promoted by **E-magic Corporation** for connecting audio software and audio hardware. Like **ASIO**, **EASI** supports both Windows and Macintosh platforms, and allows high-quality multi-channel input/output.

The RPC-1 comes with an EASI driver for **Windows 98/Me/2000**.

\* *Name of the EASI driver for Windows 98/Me is "M Audio Delta EASI."*

#### Windows MME driver (Windows)

**Windows MME** (Multimedia Extensions) is the standard multimedia function extension standard for Windows.

To specify that the RPC-1 is to handle input/output of the system sound, make the following settings.

1. From the "**Start**" menu, select the "**Control Panel**," and open "**Multimedia**."
2. In the "**Audio**" tab, specify the RPC-1 as the preferred input/output device for **playback** and **recording**.

#### Sound Manager driver

Sound Manager is the standard digital sound specification for Mac OS.

To specify the RPC-1 as the output destination of Sound Manager, make the following settings.

1. From the "**control panel**" of the "**Apple menu**," open "**Sound**."
2. From the pull-down menu, choose "**Sound In**" or "**Sound Out**," and select the "**RPC-1**" for input and output.

#### NOTE

For both input and output, Sound Manager is able to handle only **16 bit 2-channel** data.

#### MIDI driver (Windows)

This is a driver for handling the RPC-1's MIDI data in Windows. A Windows MME compatible MIDI driver is included with the RPC-1.

#### MIDI driver (Mac OS)

This is an OMS driver for handling the RPC-1's MIDI data on the Macintosh. OMS 2.3.8 is required in order to use this. Opcode Corporation's OMS 2.3.8 MIDI driver is included with the RPC-1.



**OMS:** This is software provided by Opcode Corporation for setting up a MIDI environment. An "**OMS 2.3.8 installer**" is included on the "**Drivers/Update**" CD-ROM that is supplied with the RPC-1.

# RPC-1 Control Panel

When you install the **RPC-1 driver**, a dedicated RPC-1 application “**RPC-1 Control Panel**” will be installed together with the driver.

## How to start up the “RPC-1 Control Panel”

- **Windows:** “Start” > “Settings” > “Control Panel” > “Roland RPC-1 H/W”
- **Macintosh:** Double click the “RPC-1 Panel” icon copied manually.

## Main functions of RPC-1 Control Panel

- Set parameters for the functions of the RPC-1
- Input/output level meters
- Input/output mixing, etc.

## Signal flow

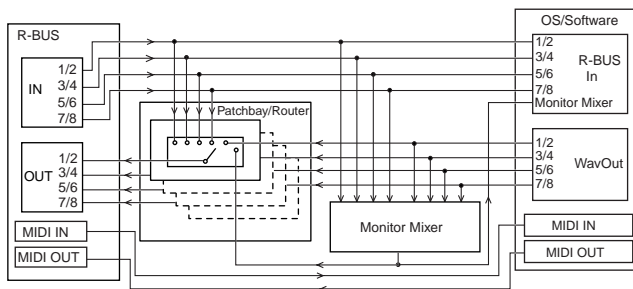

The signal flow is as shown in the diagram.

- R-BUS In
- WavOut
- Monitor Mixer
- MIDI In, MIDI Out

are used as the software input/output.



The signals that are output from the R-BUS of the RPC-1 can be selected in the control panel. For details refer to “Patchbay/Router page” in this chapter.

## RPC-1 Control Panel

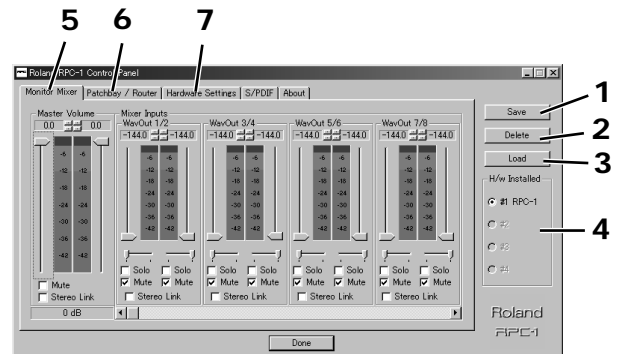

### 1. Save button

Assign a name to the settings and save them. (On the Macintosh, select “Save” from the “File” menu.)

### 2. Delete button

Delete saved settings. (This function does not exist on the Macintosh.)

### 3. Load button

Load the saved settings. (On the Macintosh, select “Open” from the “File” menu.)



The RPC-1 Control Panel always retains the last settings entered. So, you don’t have to save the setting every time you close out the panel. However the Save, Delete, and Load functions expand this capability to store different sets of control panel settings using different configuration file names. These configurations are then available for recall at a later date and time.

### 4. H/W Installed

If multiple RPC-1 units are installed, select the RPC-1 for which you wish to make settings. For details on how the RPC-1 units are numbered, refer to p. 17 “Using multiple RPC-1 units.”

## 5. Monitor Mixer page

You can use the **Monitor Mixer** to mix the input/output into two channels and record or monitor it. Mixing is performed within the RPC-1, and does not burden the CPU.

- **Level meter:** This shows the pre-fader level.
- **Faders:** Adjust the amount sent to Master.
- **Solo:** Solo ON/OFF
- **Mute:** Track mute ON/OFF
- **Stereo Link:** Stereo link ON/OFF
- **Master Volume:** Adjust the amount of Master

The settings here, such as fader and mute, do not affect the **R-BUS In, WavOut** devices



By default, all inputs of the **RPC-1 Monitor Mixer** are muted.

## 6. Patchbay/Router page

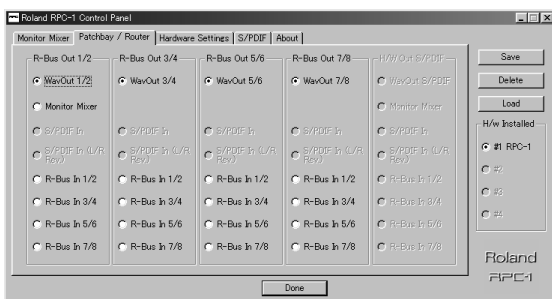

Select the R-BUS output source. “WavOut,” “R-BUS In” will be selected. Normally select “WavOut.” For “R-BUS Out 1/ 2” you can select “Monitor Mixer.”

## 7. Hardware Settings page

In this page you can make various settings for the RPC-1.

### Master Clock

Select the master clock.

- **Int. Clock:** The RPC-1 will be the **word clock master**. In this case, set the connected R-BUS device (or other RPC-1 unit) as the slave.
- **Ext. Clock:** The RPC-1 will be the **word clock slave** (synchronize to another R-BUS device or another RPC-1 unit.) In this case, set the other R-BUS device (or the other RPC-1 unit) as the master.
- **Int.Clock Sample Rate:** Select the sampling frequency used when **Master Clock** is set to **Int. Clock**.
- **Reset Rate When Idle:** If this is checked, the sampling frequency will return to the value that's been selected in the control panel after the device is released by the software.

- **Ext. Clock Sample Rate:** Select the sampling frequency used when **Master Clock** is set to **Ext. Clock**. Only the sampling frequency selected here can be used by the software.



If the master clock is set to **Ext. Clock**, it is not possible to change the sampling frequency using the software.

### DMA Buffer Size

Specify the buffer sizes for **MME** (Windows only), **ASIO**, and **Sound Manager** (Macintosh only). The buffer size is closely related to latency, and latency will decrease as you decrease the buffer size.



Depending on the performance of your computer, the digital data may not be transmitted correctly if the buffer size is too small, and noise may occur. In such cases, increase the buffer size.



Depending on the software you are using, it may be necessary to set the buffer size within the software. For details, refer to the manual for the software you are using.

\* *The default buffer size values are as follows:*

**Windows 95/98/Me/NT:** Latency 20 ms

**Windows 2000 :** Wave 10 ms, ASIO 2700 samples

**Macintosh:** ASIO, Sound Manager 1 024 samples

### Multi-Track Driver Devices (Windows95/98/ Me only)

Specify how software will handle MME devices.

- **Single and In-Sync:** When using one software application to handle all MME devices simultaneously. This guarantees the synchronization of each MME device.
- **Independent:** When using separate software applications to handle each MME device.
- **Multiple Card Sync:** When using multiple RPC-1 units simultaneously for more reliability of synchronization.

### Sound Manager I/O (Macintosh only)

Select the R-BUS channel used by Sound Manager.

### Disable Control of the Monitor Mixer and Patchbay/Router by Audio Applications (Windows95/98/Me only)

Check to disable control of the **Monitor Mixer** and **patchbay/Router** by the applications.

# Connections with other R-BUS devices

## Connections with R-BUS devices

In order to transfer digital audio signals between R-BUS devices, the **sampling frequency** of the devices must match, and they must share the same **word clock**. In order for the word clock to be shared, one device in the system must be the **word clock master**. Other devices must be set to share that clock (i.e., they must be **slaves**). The RPC-1 can function either as the word clock master or slave.

### NOTE

If two or more word clock master devices exist in the system, the word clock will not be shared correctly. In such cases, the digital audio signals will not be transferred accurately, and noise will occur. Be sure that only one device is the word clock master.

## Connections with the VM-3100Pro

### Updating the system program (Ver. 1.052)

In order for the VM-3100Pro to be connected and used with the RPC-1, system program **version 1.052 or later** is required. If your VM-3100Pro is **version 1.04 or earlier**, you must update the system program.

### How to check the software version

When the power is turned on, the lower line of the opening screen will show the version number as (for example) "**Ver. 1.04.**"

### How to update

The directory "**UPDATE > VM-3100**" in the included "**Drivers/Update**" CD-ROM contains the data for the update. Perform the update procedure as directed in the "**readme.doc**" file.

### Example settings

#### RPC-1 settings (in the Control Panel)

- **Master Clock:** Int. Clock
- **Int. Clock Sample Rate:** 44.1 kHz

### MEMO

The VM-3100Pro operates at a sampling frequency of **44.1 kHz**.

### VM-3100Pro settings

Use **Quick Setup** to make VM-3100Pro settings. (For details refer to "**VM-3100Pro Quick Setup**" in this chapter.)

You can use the VM-3100Pro's **inputs 1-8** as inputs of the RPC-1. The outputs of the RPC-1 will be sent to **inputs 13-20** of the VM-3100Pro. You can use the **MIDI faders, transport, and value dial** of the VM-3100Pro to remotely control your sequencer software, and perform **automix** on the VM-3100Pro. For details refer to the following pages of the **VM-3100 user's manual: p. 43 "Controlling a MIDI sequencer," p. 56 "MIDI," and p. 46 "Using a personal computer for auto-fader functionality."** Also refer to the manual of the sequencer software that you are using. You can also use the VM-3100Pro as **MIDI interface** for your computer.

### MEMO

The routing can be changed. For details refer to **VM-3100 user's manual p. 51 "Easy routing."**

### MEMO

In order to use the VM-3100Pro's Digital In, set the master clock of the VM-3100Pro to **DinA or DinB**, and set the master clock of the RPC-1 to **Ext. Clock**.

### NOTE

In order for the VM-3100Pro to control sequencer software, that sequencer software must support **MIDI control of transport, locate, and fader control**. For details refer to the manual of the sequencer software you are using.

### VM-3100Pro Quick Setup

By using Quick Setup, you can instantly recall settings for use with a connected RPC-1. At this time, settings for remotely controlling your sequencer software will also be recalled. The following types of Quick Setup are available.

Software to be controlled	Setting method
Logic Audio	[SHIFT] + [F1]
Cakewalk	[SHIFT] + [F2]
Cubase VST	[SHIFT] + [F3]

When you perform one of the above operations, the display will ask “Load xxxx Configuration?” (xxxx is either **LOGIC**, **CAKEWALK**, or **CUBASE**). Press [ENTER/YES].



When Quick Setup is executed, the following parameters and routings will be changed.

Parameter	Value set	Location	Explanation
M.clk Select	RMDB-2	[Shift] + [Digital in]	Set as slave of RPC-1
Master Source	MIX	Master [Select]	VM-3100Pro monitors the signal sent to the RPC-1
LocatorType	MEASURE	[System]	Use locator to transmit SPP
Control Type	Off	[System] → [F1-F4] → [MIDI]	Don't transmit Audio fader values
Timing Mon.	MEASURE	[System] → [F1-F4] → [MIDI]	Measure is received as timing data
Beat	4/4	[System] → [F1-F4] → [MIDI]	4/4 time signature
R-BUS Target	RPC-1	[System] → [F1-F4] → [MIDI]	Connect with RPC-1
Transport	USER1	[System] → [F1-F4] → [MIDI]	Transmit USER1 note
ShiftKey	OFF or C-1	[System] → [F1-F4] → [MIDI]	OFF for Logic. Otherwise, C-1
USER1	Settings for each program	[System] → [F1-F4] → [MIDI] → [F1-F4]	Overwrite to USER1
EZR SEL	RMDB DIRECT	[EZ Routing]	Send Input 1-8 to R-BUS

### Connections with the VM-7200/7100

In order to connect the VM-7200/7100 with the RPC-1, the **VM-24E I/O expansion board** (an expansion board that adds an R-BUS connector) must be installed in the VM-7200/7100.

#### Updating the system program

In order for the VM-7200/7100 to be connected and used with the RPC-1, system program **version 1.60 or later** is required. If your VM-7200/7100 has **version 1.50 or earlier**, you must update the system program.

#### Checking the version

After starting up the VM-7200/7100 system, press [on Display] and [9]. **Unit 1/2 Version** is the version of the VM-7200/7100.

#### Updating the system program

The directory “**UPDATE > VM-7000**” in the included “**Drivers/Update**” CD-ROM contains the data for the update. Perform the update procedure as directed by the “**readme.doc**” file.

#### Example settings

##### RPC-1 settings (in the Control Panel)

- **Master Clock:** Int. Clock
- **Int. Clock Sample Rate:** either 32, 44.1, or 48 kHz

##### VM-C7200/7100 settings

- **WORD CLOCK SOURCE:** MULTI 1-8

Use the VM-7200/7100 **patchbay** to assign the inputs of the VM-7200/7100 to the RPC-1.

The output of the RPC-1 will be input to **MULTI-IN**. You can also use multiple RPC-1 units simultaneously. For details refer to p. 17 “**Using multiple RPC-1 units.**”

## Connections with the XV-5080

---

### Example settings

#### RPC-1 settings (in the Control Panel)

- **Master Clock:** Int. Clock
- **Int.Clock Sample Rate:** either 44.1 or 48 kHz

### XV-5080 settings

- **Master Clock:** R-BUS

For details on output destination settings of the XV-5080, refer to “**Chapter 3. Setting the output jacks**” in the XV-5080 manual.



The R-BUS of the XV-5080 is for output only. It cannot be used for input to the XV-5080.



It is not possible to make MIDI connections using the R-BUS of the XV-5080. To make MIDI connections, use the MIDI connectors of the XV-5080.

## Connections with the ADA-7000

---

### Updating the system program

The **version 1.02 or later** system program is required in order to connect and use the ADA-7000 with the RPC-1.

### Updating the system program

The directory “**UPDATE > ADA-7000**” in the included “**DRIVER/UPDATE CD-ROM**” contains the data for the update. Perform the update procedure as directed by the “**readme.doc**” file.

### Example settings

#### RPC-1 settings (in the Control Panel)

- **Master Clock:** Int. Clock
- **Int. Clock Sample Rate:** either 32, 44.1, 48, or 96 kHz

### ADA-7000 settings

- **Master Clock:** R-BUS

The analog inputs and outputs of the ADA-7000 can be used as inputs and outputs of the RPC-1.



If you are using a sampling frequency of **96 kHz**, using a five meter R-BUS cable (RBC-5) may cause noise to occur. If you are using a frequency of **96 kHz**, use shorter cable.

## Connections with the AE-7000

---

### Updating the system program

The **version 1.01 or later** system program is required in order to connect and use the AE-7000 with the RPC-1.

### Updating the system program

The directory “**UPDATE > AE-7000**” in the included “**DRIVER/UPDATE CD-ROM**” contains the data for the update. Perform the update procedure as directed in the “**readme.doc**” file.

### Example settings

#### RPC-1 settings (in the Control Panel)

- **Master Clock:** Int. Clock
- **Int. Clock Sample Rate:** either 32, 44.1, or 48 kHz

### AE-7000 settings

- **Master Clock:** R-BUS

### Connections with the VSR-880

#### Updating the system program

System program **version 1.03 or later** is required in order to connect and use the VSR-880 with the RPC-1. If your VSR-880 has **version 1.02 or earlier**, the system program must be updated.

#### Checking the version

When the power is turned on, the lower line of the opening screen will show the version as (for example) “– Ver. 1.02 –.”

#### Updating the system program

The directory “**UPDATE > VSR-880**” in the included “**DRIVER/UPDATE CD-ROM**” contains the data for the update. Perform the update procedure as directed in the “**readme.doc**” file.

#### Example settings

##### RPC-1 settings (in the Control Panel)

- **Master Clock:** Int. Clock
- **Int. Clock Sample Rate:** either 32, 44.1, or 48 kHz (match the setting of the VSR-880)

##### VSR-880 settings

- **Master Clock:** R-BUS
  - **System PRM** → **RBUSMute:** Disable\*
  - Execute **Shutdown**([SHIFT]+[SHUT/EJECT]/(STOP)) whenever you change **RBUSMute**.
- \* **RBUSMute** is a parameter that was newly added in version 1.03 in order to support the RPC-1. If you are connecting an earlier R-BUS device, set **RBUSMute=Enable**.

#### MEMO

The **RBUSMute** parameter applies to the entire system; not to an individual song.

#### MEMO

In order to use the VSR-880's R-BUS input, each input of the input mixer must be set to **R-BUS**. For details, refer to “**Channel condition**” on p. 79 in the “**VSR-880 owner's manual**.”

#### MEMO

If you wish to output each track of the VSR-880 to a separate channel, go to **[LEVEL/BALANCE] → (Parameter)[>] x9** and set “**MST Direct Out = On**.”

### Connections with the VS-2480

#### Example settings

##### RPC-1 settings (in the Control Panel)

- **Master Clock:** Int. Clock
- **Int.Clock Sample Rate:** either 32, 44.1, 48, 88.2 or 96kHz

#### VS-2480 settings

- **Master Clock:** R-BUS

#### MEMO

If you connect two RPC-1 units to a VS-2480, set the VS-2480 as the **word clock master**, and set each of the RPC-1's as its **slave**. And then, turn the **SW-1** on of each RPC-1. Notice that each RPC-1 must receive word clock from R-BUS. For details refer to p. 6 “**Names of Things and what they do**” and p. 17 “**Using multiple RPC-1 units**.”

#### NOTE

If you are using a sampling frequency of **88.2 kHz** or **96 kHz**, it is not possible to use a **clock cable** to synchronize multiple RPC-1 units. Supply the word clock via R-BUS.

#### NOTE

If you are using a sampling frequency of **88.2** or **96 kHz**, using a five meter R-BUS cable (RBC-5) may cause noise to occur. If you are using a frequency of **88.2** or **96 kHz**, use shorter cable.



# Using multiple RPC-1 units

## Settings for using multiple RPC-1 units

Up to four RPC-1 units can be used in a single computer. Each RPC-1 is assigned a number from 1 through 4 in the order in which the card was recognized (in general, starting at the lowest-numbered PCI slot).

Immediately after an additional RPC-1 is added to a computer in which an RPC-1 has already been installed (i.e., immediately after the driver is installed), the highest number will be assigned to that RPC-1. Each subsequent time the computer is started up, the card will be assigned a number in the order in which it was detected.

Settings for each card are made in the RPC-1 Control Panel. For details refer to p. 11 “RPC-1 Control Panel.”

In order to use multiple RPC-1 units simultaneously, all cards and R-BUS devices must be synchronized.

## Synchronizing multiple RPC-1 units

In order to synchronize multiple RPC-1 units, all RPC-1 units must be set to the same sampling frequency, and share the same word clock. The word clock can be shared in the following two ways.

### 1. Supplying the word clock from R-BUS

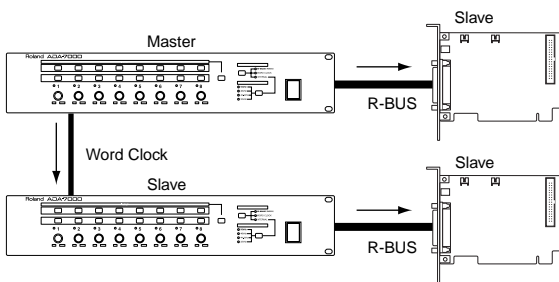

Set an external R-BUS device or one of the RPC-1 units as the **word clock master**, and supply the word clock via the external R-BUS device to the remaining RPC-1 unit(s). Set the master clock to **Ext. Clock** on each **slave** RPC-1 (to which the word clock is supplied).

### MEMO

If Master Clock is set to **Ext. Clock**, and a clock is input from both the **Clock In Connector** and **R-BUS**, the **Clock In Connector** will take priority. If you wish to input the word clock **from R-BUS**, disconnect the **clock cable**.

### 2. Using the included clock cable to supply the word clock

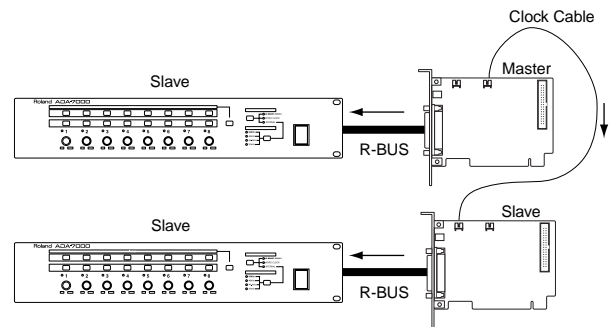

Set an external R-BUS device or one of the RPC-1 units as the **word clock master**, and supply the word clock via the **clock cable** to the other RPC-1 unit(s). In this case, use the included clock cable to connect the **Clock Out Connector** of the device supplying the word clock to the **Clock In Connector** of the device receiving the word clock. Set the master clock to **Ext. Clock** on each **slave** RPC-1 unit that is receiving the word clock.

### NOTE

If you are using a sampling frequency of **88.2 kHz** or **96 kHz**, it is not possible to use a **clock cable** to synchronize multiple RPC-1 units. Supply the word clock via R-BUS.

### MEMO

If Master Clock is set to **Ext. Clock**, and a clock is input from both the **Clock In Connector** and **R-BUS**, the **Clock In Connector** will take priority. If you wish to input the word clock **from R-BUS**, disconnect the **clock cable**.

### NOTE

**RPC-1 Driver ver.1.0.2 for Macintosh** doesn't support simultaneous use of multiple RPC-1 units. This function will be supported in the near future.

# Software settings

This section explains the audio device settings that should be made in order to use the RPC-1 with some representative sequencer programs.

## Logic Audio settings

---

### Audio device settings

#### When using the ASIO driver

1. From the “**Audio**” menu, select “**Audio Hardware & Drivers.**” On the Windows version, click “**Audio Hardware & Drivers2**” tab.
2. Check “**ASIO,**” and from the pull-down menu choose “**Roland RPC-1 ASIO**” (Win) or “**ASIO2 RPC-1**” (Mac).

#### When using the EASI driver (Windows)

1. From the “**Audio**” menu, select “**Audio Hardware & Drivers.**”
2. Check “**PC AV,**” and select “**Roland RPC-1 EASI.**”

#### When using the MME driver (Windows)

1. From the “**Audio**” menu, select “**Audio Hardware & Drivers.**”
2. Check “**PC AV,**” and select “**EASI MME.**”
3. Click the “**Control Panel**” button, and start up “**MME to EASI adapter.**”
4. Check the following devices.
  - **WavOut Roland RPC-1**
  - **R-BUS In Roland RPC-1**
  - **Monitor Mixer Roland RPC-1**

## Cubase VST settings

---

### Audio device settings

1. In the “**Options**” menu, select “**Audio Setup**” and then select “**System.**”
2. Select “**Roland RPC-1 ASIO**”(Win) or “**ASIO RPC-1**” (Mac).

## Sonar settings (Windows)

---

### Audio device settings (Windows 98/ME)

1. From the “**Options**” menu, select “**Audio.**”
2. In the “**Settings**” tab, click “**Devices.**”
3. In the “**Input Device**” area select following device.
  - **PCM In Roland RPC-1**
  - **Mon.Mixer Roland RPC-1**
4. In the “**Output Device**” area select “**WavOut Roland RPC-1.**”
5. Set the “**playback timing master**” to “**WavOut 1/2 Roland RPC-1,**” and the “**recording timing master**” to “**PCM In 1/2 Roland RPC-1.**”
6. Click the “**OK**” button.

### Audio device settings (Windows 2000/XP)

1. From the “**Options**” menu, select “**Audio.**”
2. In the “**Settings**” tab, click “**Devices.**”
3. In the “**Input Device**” area select “**Roland RPC-1 Multichannel 1/2**”–“**Roland RPC-1 Multichannel 9/10.**”
4. In the “**Output Device**” area select “**Roland RPC-1 Multichannel 1/2**”–“**Roland RPC-1 Multichannel 7/8.**”
5. Set the “**playback timing master**” to “**Roland RPC-1 Multichannel 1/2,**” and the “**recording timing master**” to “**Roland RPC-1 Multichannel 1/2.**”
6. Click the “**OK**” button.

# Troubleshooting

Problem	Suggestion
Can't install RPC-1 in computer	Is the RPC-1 oriented correctly?
RPC-1 Control Panel won't start up	Is the RPC-1 inserted correctly in the PCI slot?
	Was the driver installed correctly?
The dialog " <b>Driver Version is older than expected! Please install latest driver.</b> " appears, when the RPC-1 Control Panel starts up. (Windows 2000)	Is the RPC-1 inserted correctly in the PCI slot?
No output/can't input	Is the R-BUS cable connected correctly?
	Are you correctly synchronized with the R-BUS device? For details refer to <b>p. 13 "Connections with R-BUS devices."</b>
	Are the input/output settings of the software correct?
Can't use MIDI	Is the R-BUS cable connected correctly?
	Was the driver installed correctly?
	Are the MIDI settings of the R-BUS device correct?
There is excessive noise or distortion	Are you correctly synchronized with the R-BUS device? For details refer to <b>p. 13 "Connections with R-BUS devices."</b>
	This kind of noise or distortion will occur when your computer has a small size of memory, e.g. less than 64MB RAM. In this case, we strongly recommend you to use more than 128MB RAM.
	Depending on the performance of your computer, the digital data may not be transmitted correctly if the buffer size is too small, and noise may occur. In such cases, increase the buffer size. For details refer to <b>p. 12 "DMA Buffer Size."</b> Depending on the software you are using, it may be necessary to set the buffer size within the software. For details, refer to the manual for the software you are using.

# Main specifications

## ■ General specifications

<b>Sampling frequency [kHz]</b>	8, 9.6, 11.025, 12, 16, 22.05, 24, 32, 44.1, 48, 88.2, 96	
<b>R-BUS</b>	<b>IN</b>	24 bit / 8 channel
	<b>OUT</b>	24 bit / 8 channel
<b>MIDI</b>	One set of IN / OUT	

## ■ Monitor mixer in control panel

<b>Number of input channels</b>	16 channels
<b>Number of output channels</b>	2 channels
<b>Faders</b>	-144 – 0 dB
<b>Level meters</b>	Pre-fader (fixed)
<b>Arithmetic precision</b>	36 bit

\* *In the interest of product improvement, the specifications and/or contents of this package are subject to change without prior notice.*

**...MEMO...**

## Information

When you need repair service, call your nearest Roland Service Center or authorized Roland distributor in your country as shown below.

### AFRICA

#### EGYPT

**Al Fanny Trading Office**  
9, EBN Hagar A1 Askalany Street,  
ARD El Golf, Heliopolis,  
Cairo 11341, EGYPT  
TEL: 20-2-417-1828

#### REUNION

**Maison FO - YAM Marcel**  
25 Rue Jules Hermainn,  
Chaudron - BP79 97 491  
Ste Clotilde Cedex,  
REUNION ISLAND  
TEL: (0262) 218-429

#### SOUTH AFRICA

**That Other Music Shop (PTY) Ltd.**  
11 Melle St., Braamfontein,  
Johannesbourg, SOUTH AFRICA

P.O.Box 32918, Braamfontein 2017  
Johannesbourg, SOUTH AFRICA  
TEL: (011) 403 4105

**Paul Bothner (PTY) Ltd.**  
17 Werdmuller Centre,  
Main Road, Claremont 7708  
SOUTH AFRICA

P.O.Box 23032, Claremont 7735,  
SOUTH AFRICA  
TEL: (021) 674 4030

### ASIA

#### CHINA

**Beijing Xinghai Musical Instruments Co., Ltd.**  
6 Huangmchang Chao Yang  
District, Beijing, CHINA  
TEL: (010) 6774 7491

**Shanghai Xingtong Acoustics Equipment CO., Ltd.**  
5F, No.1500 Pingliang Road  
New East Club Plaza, Shanghai,  
CHINA  
TEL: (021) 5580-0800

#### HONG KONG

**Tom Lee Music Co., Ltd. Service Division**  
22-32 Pun Shan Street, Tsuen  
Wan, New Territories,  
HONG KONG  
TEL: 2415 0911

#### INDIA

**Rivera Digitec (India) Pvt. Ltd.**  
409, Nirman Kendra Mahalaxmi  
Flats Compound Off. Dr. Edwin  
Moses Road, Mumbai-400011,  
INDIA  
TEL: (022) 493 9051

#### INDONESIA

**PT Citra IntiRama**  
Jl. Cideng Timur No. 15J-150  
Jakarta Pusat  
INDONESIA  
TEL: (021) 6324170

#### KOREA

**Cosmos Corporation**  
1461-9, Seocho-Dong,  
Seocho Ku, Seoul, KOREA  
TEL: (02) 3486-8855

#### MALAYSIA

**BENTLEY MUSIC SDN BHD**  
140 & 142, Jalan Bukit Bintang  
55100 Kuala Lumpur, MALAYSIA  
TEL: (03) 2144-3333

#### PHILIPPINES

**G.A. Yupangco & Co. Inc.**  
339 Gil J. Puyat Avenue  
Makati, Metro Manila 1200,  
PHILIPPINES  
TEL: (02) 899 9801

#### SINGAPORE

**Swee Lee Company**  
150 Sims Drive  
SINGAPORE 387381  
TEL: 6846-3676

#### CRISTOFORI MUSIC PTE LTD

Blk 3014, Bedok Industrial Park E,  
#02-2148, SINGAPORE 489980  
TEL: 6243-9555

#### TAIWAN

**ROLAND TAIWAN ENTERPRISE CO., LTD.**  
Room 5, 9fl. No. 112 Chung Shan  
N.Road Sec.2, Taipei, TAIWAN,  
R.O.C.  
TEL: (02) 2561 3339

#### THAILAND

**Theera Music Co., Ltd.**  
330 Verng NakornKasem, Soi 2,  
Bangkok 10100, THAILAND  
TEL: (02) 2248821

#### VIETNAM

**Saigon Music**  
138 Tran Quang Khai St.,  
District 1  
Ho Chi Minh City  
VIETNAM  
TEL: (08) 844-4068

### AUSTRALIA/ NEW ZEALAND

#### AUSTRALIA

**Roland Corporation Australia Pty., Ltd.**  
38 Campbell Avenue  
Dee Why West, NSW 2099  
AUSTRALIA  
TEL: (02) 9982 8266

#### NEW ZEALAND

**Roland Corporation Ltd.**  
32 Shaddock Street, Mount Eden,  
Auckland, NEW ZEALAND  
TEL: (09) 3098 715

### CENTRAL/LATIN AMERICA

#### ARGENTINA

**Instrumentos Musicales S.A.**  
Av.Santa Fe 2055  
(1123) Buenos Aires  
ARGENTINA  
TEL: (011) 4508-2700

#### BRAZIL

**Roland Brasil Ltda**  
Rua San Jose, 780 Sala B  
Parque Industrial San Jose  
Cotia - Sao Paulo - SP, BRAZIL  
TEL: (011) 4615 5666

#### COSTA RICA

**JUAN Bansbach Instrumentos Musicales**  
Ave.1. Calle 11, Apartado 10237,  
San Jose, COSTA RICA  
TEL: 258-0211

#### CHILE

**Comercial Fancy II S.A.**  
Rut.: 96.919.420-1  
Nataníel Cox #739, 4th Floor  
Santiago - Centro, CHILE  
TEL: (02) 688-9540

#### EL SALVADOR

**OMNI MUSIC**  
75 Avenida Norte y Final  
Alameda Juan Pablo II,  
Edificio No.4010 San Salvador,  
EL SALVADOR  
TEL: 262-0788

#### MEXICO

**Casa Veerkamp, s.a. de c.v.**  
Av. Toluca No. 323, Col. Olivar  
de los Padres 01780 Mexico D.F.  
MEXICO  
TEL: (55) 5668-6699

#### PANAMA

**SUPRO MUNDIAL, S.A.**  
Boulevard Andrews, Albrook,  
Panama City, REP. DE PANAMA  
TEL: 315-0101

#### PARAGUAY

**Distribuidora De Instrumentos Musicales**  
J.E. Olear y ESQ. Manduvira  
Asuncion PARAGUAY  
TEL: (021) 492-124

#### URUGUAY

**Todo Musica S.A.**  
Francisco Acuna de Figueroa 1771  
C.P.: 11.800  
Montevideo, URUGUAY  
TEL: (02) 924-2335

#### VENEZUELA

**Mexiland Digital C.A.**  
Av. Francisco de Miranda,  
Centro Parque de Cristal, Nivel  
C2 Local 20 Caracas  
VENEZUELA  
TEL: (212) 285-8586

### EUROPE

#### AUSTRIA

**Roland Austria GES.M.B.H.**  
Siemensstrasse 4, P.O. Box 74,  
A-6063 RUM, AUSTRIA  
TEL: (0512) 26 44 260

#### BELGIUM/HOLLAND/ LUXEMBOURG

**Roland Benelux N. V.**  
Houtstraat 3, B-2260, Oevel  
(Westerlo) BELGIUM  
TEL: (014) 575811

#### DENMARK

**Roland Scandinavia A/S**  
Nordhavnsvej 7, Postbox 880,  
DK-2100 Copenhagen  
DENMARK  
TEL: (039)16 6200

#### FRANCE

**Roland France SA**  
4, Rue Paul Henri SPAAK,  
Parc de l'Esplanade, F 77 462 St.  
Thibault, Lagny Cedex FRANCE  
TEL: 01 600 73 500

#### FINLAND

**Roland Scandinavia As, Filial Finland**  
Lauttasaarentie 54 B  
Fin-00201 Helsinki, FINLAND  
TEL: (9) 682 4020

#### GERMANY

**Roland Elektronische Musikinstrumente HmbH.**  
Oststrasse 96, 22844 Norderstedt,  
GERMANY  
TEL: (040) 52 60090

#### GREECE

**STOLLAS S.A. Music Sound Light**  
155, New National Road  
Patras 26442, GREECE  
TEL: (061) 043-5400

#### HUNGARY

**Intermusica Ltd.**  
Warehouse Area 'DEPO' Pf.83  
H-2046 Torokbalint, HUNGARY  
TEL: (23) 511011

#### IRELAND

**Roland Ireland**  
Audio House, Belmont Court,  
Donnybrook, Dublin 4,  
Republic of IRELAND  
TEL: (01) 2603501

#### ITALY

**Roland Italy S. p. A.**  
Viale delle Industrie 8,  
20020 Arese, Milano, ITALY  
TEL: (02) 937-78300

#### NORWAY

**Roland Scandinavia Avd. Kontor Norge**  
Lilleakerveien 2 Postboks 95  
Lilleaker N-0216 Oslo  
NORWAY  
TEL: 273 0074

#### POLAND

**P. P. H. Brzostowicz**  
UL. Gibraltarska 4,  
PL-03664 Warszawa POLAND  
TEL: (022) 679 44 19

#### PORTUGAL

**Tecnologias Musica e Audio, Roland Portugal, S.A.**  
Cais Das Pedras, 8/9-1 Dto  
4050-465 PORTO  
PORTUGAL  
TEL: (022) 608 00 60

#### ROMANIA

**FBS LINES**  
Piata Libertatii 1,  
RO-4200 Gheorgheni  
TEL: (095) 169-5043

#### RUSSIA

**MuTek**  
3-Bogatyrskaya Str. 1.k.1  
107 564 Moscow, RUSSIA  
TEL: (095) 169 5043

#### SPAIN

**Roland Electronics de España, S. A.**  
Calle Bolivia 239, 08020  
Barcelona, SPAIN  
TEL: (93) 308 1000

#### SWEDEN

**Roland Scandinavia A/S SWEDISH SALES OFFICE**  
Danvik Center 28, 2 tr.  
S-131 30 Nacka SWEDEN  
TEL: (08) 702 0020

#### SWITZERLAND

**Roland (Switzerland) AG Musitronic AG**  
Gerberstrasse 5, Postfach,  
CH-4410 Liestal, SWITZERLAND  
TEL: (061) 927-8383

#### UKRAINE

**TIC-TAC**  
Mira Str. 19/108  
P.O. Box 180  
295400 Munkachevo, UKRAINE  
TEL: (03131) 414-40

#### UNITED KINGDOM

**Roland (U.K.) Ltd.**  
Atlantic Close, Swansea  
Enterprise Park, SWANSEA  
SA7 9FJ,  
UNITED KINGDOM  
TEL: (01792) 700139

### MIDDLE EAST

#### BAHRAIN

**Moon Stores**  
No.16, Bab Al Bahrain Avenue,  
P.O.Box 247, Manama 304,  
State of BAHRAIN  
TEL: 211 005

#### CYPRUS

**Radex Sound Equipment Ltd.**  
17, Diagorou Street, Nicosia,  
CYPRUS  
TEL: (02) 66-9426

#### IRAN

**MOCO, INC.**  
No.41 Nike St., Dr.Shariyati Ave.,  
Roberoye Cerahe Mirdamad  
Tehran, IRAN  
TEL: (021) 285-4169

#### ISRAEL

**Halilit P. Greenspoon & Sons Ltd.**  
8 Retzif Ha'aliya Hashnya St.  
Tel-Aviv-Yafo ISRAEL  
TEL: (03) 6823666

#### JORDAN

**AMMAN Trading Agency**  
245 Prince Mohammad St.,  
Amman 1118, JORDAN  
TEL: (06) 464-1200

#### KUWAIT

**Easa Husain Al-Yousifi**  
Abdullah Salem Street,  
Safat, KUWAIT  
TEL: 243-6399

#### LEBANON

**Chahine S.A.L.**  
Gerge Zeidan St., Chahine Bldg.,  
Achrafieh, P.O.Box: 16-5857  
Beirut, LEBANON  
TEL: (01) 20-1441

#### QATAR

**Al Emadi Co. (Badie Studio & Stores)**  
P.O. Box 62,  
Doha, QATAR  
TEL: 4423-554

#### SAUDI ARABIA

**aDawlah Universal Electronics APL**  
Corniche Road, Aldossary Bldg.,  
1st Floor, Alkhobar,  
SAUDI ARABIA

P.O.Box 2154, Alkhobar 31952  
SAUDI ARABIA  
TEL: (03) 898 2081

#### SYRIA

**Technical Light & Sound Center**  
Khaled Ebn Al Walid St.  
Bldg. No. 47, P.O.Box 13520,  
Damascus, SYRIA  
TEL: (011) 223-5384

#### TURKEY

**Barkat muzik aletleri ithalat ve ihracat Ltd Sti**  
Siraselviler Caddesi Siraselviler  
Pasaji No:74/20  
Taksim - Istanbul, TURKEY  
TEL: (0212) 2499324

#### U.A.E.

**Zak Electronics & Musical Instruments Co. L.L.C.**  
Zabeel Road, Al Sherooq Bldg.,  
No. 14, Grand Floor, Dubai, U.A.E.  
TEL: (04) 3360715

### NORTH AMERICA

#### CANADA

**Roland Canada Music Ltd. (Head Office)**  
5480 Parkwood Way Richmond  
B. C., V6V 2M4 CANADA  
TEL: (604) 270 6626

#### Roland Canada Music Ltd. (Toronto Office)

170 Admiral Boulevard  
Mississauga On L5T 2N6  
CANADA  
TEL: (905) 362 9707

#### U. S. A.

**Roland Corporation U.S.**  
5100 S. Eastern Avenue  
Los Angeles, CA 90040-2938,  
U. S. A.  
TEL: (323) 890 3700

As of May 1, 2002 (Roland)

### RPC-1 driver software support

Phone : 626 - 445 - 8495 (United States)

Fax : 626 - 445 - 7564 (United States)

e-mail : techsupt@midiman.net

- \* Microsoft, Windows, and Windows NT are registered trademarks of Microsoft Corporation.
- \* Windows® 95 is known officially as: "Microsoft® Windows® 95 operating system."
- \* Windows® 98 is known officially as: "Microsoft® Windows® 98 operating system."
- \* Windows NT® is known officially as: "Microsoft® Windows NT® operating system."
- \* Windows® 2000 is known officially as: "Microsoft® Windows® 2000 operating system."
- \* Windows® Me is known officially as: "Microsoft® Windows® Millennium Edition operating system."
- \* Windows® XP is known officially as: "Microsoft® Windows® XP operating system."
- \* Macintosh is a registered trademark of Apple Computer, Inc.
- \* MacOS is a trademark of Apple Computer, Inc.
- \* Pentium is a registered trademark of Intel Corporation.
- \* MMX is a trademark of Intel Corporation.
- \* OMS is a trademark of Opcode System, Inc.
- \* Sonar is a trademark of Twelve Tone Systems, Inc.
- \* Logic Audio and EASI is a trademark of Emagic Soft- und Hardware GmbH.
- \* Cubase VST and ASIO is trademark of Steinberg Media Technologies AG.
- \* All product names mentioned in this document are trademarks or registered trademarks of their respective owners.



For EU Countries

This product complies with the requirements of European Directive 89/336/EEC.

For the USA

## FEDERAL COMMUNICATIONS COMMISSION RADIO FREQUENCY INTERFERENCE STATEMENT

This equipment has been tested and found to comply with the limits for a Class B digital device, pursuant to Part 15 of the FCC Rules. These limits are designed to provide reasonable protection against harmful interference in a residential installation. This equipment generates, uses, and can radiate radio frequency energy and, if not installed and used in accordance with the instructions, may cause harmful interference to radio communications. However, there is no guarantee that interference will not occur in a particular installation. If this equipment does cause harmful interference to radio or television reception, which can be determined by turning the equipment off and on, the user is encouraged to try to correct the interference by one or more of the following measures:

- Reorient or relocate the receiving antenna.
- Increase the separation between the equipment and receiver.
- Connect the equipment into an outlet on a circuit different from that to which the receiver is connected.
- Consult the dealer or an experienced radio/TV technician for help.

This device complies with Part 15 of the FCC Rules. Operation is subject to the following two conditions:

- (1) This device may not cause harmful interference, and
- (2) This device must accept any interference received, including interference that may cause undesired operation.

Tested To Comply With FCC Standards

**FOR HOME OR OFFICE USE**

Unauthorized changes or modification to this system can void the users authority to operate this equipment.  
This equipment requires shielded interface cables in order to meet FCC class B Limit.

For the USA

## Declaration of Conformity COMPLIANCE INFORMATION STATEMENT

Model Name	: RPC-1
Type of Equipment	: R-BUS Interface Card
Responsible Party	: Roland Corporation U.S
Address	: 5100 S. Eastern Avenue, Los Angeles, CA 90040-2938
Telephone	: (323) 890-3700

For Canada

### NOTICE

This Class B digital apparatus meets all requirements of the Canadian Interference-Causing Equipment Regulations.

### AVIS

Cet appareil numérique de la classe B respecte toutes les exigences du Règlement sur le matériel brouilleur du Canada.

This owner's manual is printed on recycled paper.

**Roland Corporation**

40458890 '02-5-GC1-21KS