



DYNAMIC **MIDI** PEDAL

# PK-5

**Owner's Manual**

For West Germany

## Bescheinigung des Herstellers/Importeurs

Hiermit wird bescheinigt, daß der/die/das

**Roland PK-5 Dynamic MIDI Pedal**

(Gerät. Typ. Bezeichnung)

in Übereinstimmung mit den Bestimmungen der

**Amtsbl. Vfg 1046/1984**

(Amtsblattverfügung)

funk-entstört ist.

Der Deutschen Bundespost wurde das Inverkehrbringen dieses Gerätes angezeigt und die Berechtigung zur Überprüfung der Serie auf Einhaltung der Bestimmungen eingeräumt.

**Roland Corporation Osaka/Japan**

Name des Herstellers/Importeurs

For the USA

## RADIO AND TELEVISION INTERFERENCE

**WARNING** — This equipment has been verified to comply with the limits for a Class B computing device, pursuant to Subpart J, of Part 15, of FCC rules. Operation with non-certified or non-verified equipment is likely to result in interference to radio and TV reception.

The equipment described in this manual generates and uses radio frequency energy. If it is not installed and used properly, that is, in strict accordance with our instructions, it may cause interference with radio and television reception. This equipment has been tested and found to comply with the limits for a Class B computing device in accordance with the specifications in Subpart J, of Part 15, of FCC Rules. These rules are designed to provide reasonable protection against such a interference in a residential installation. However, there is no guarantee that the interference will not occur in a particular installation. If this equipment does cause interference to radio or television reception, which can be determined by turning the equipment on and off, the user is encouraged to try to correct the interference by the following measure:

- Disconnect other devices and their input/output cables one at a time. If the interference stops, it is caused by either the other device or its I/O cable. These devices usually require Roland designated shielded I/O cables. For Roland devices, you can obtain the proper shielded cable from your dealer. For non Roland devices, contact the manufacturer or dealer for assistance.
- If your equipment does cause interference to radio or television reception, you can try to correct the interference by using one or more of the following measures:
  - Turn the TV or radio antenna until the interference stops.
  - Move the equipment to one side or the other of the TV or radio.
  - Move the equipment farther away from the TV or radio.
  - Plug the equipment into an outlet that is on a different circuit than the TV or radio. (That is, make certain the equipment and the radio or television set are on circuits controlled by different circuit breakers or fuses.)
  - Consider installing a rooftop television antenna with coaxial cable lead-in between the antenna and TV. If necessary, you should consult your dealer or an experienced radio-television technician for additional suggestions. You may find helpful the following booklet prepared by the Federal Communications Commission: "How to Identify and Resolve Radio — TV Interference Problems"

This booklet is available from the U.S. Government Printing Office, Washington, D.C., 20402, Stock No. 004-000-00345-4.

For Canada

### CLASS B

### NOTICE

This digital apparatus does not exceed the Class B limits for radio noise emissions set out in the Radio Interference Regulations of the Canadian Department of Communications.

### CLASSE B

### AVIS

Cet appareil numérique ne dépasse pas les limites de la classe B au niveau des émissions de bruits radioélectriques fixés dans le Règlement des signaux parasites par le ministère canadien des Communications.

Copyright © 1990 by ROLAND CORPORATION

All rights reserved. No part of this publication may be reproduced in any form without the written permission of ROLAND CORPORATION.

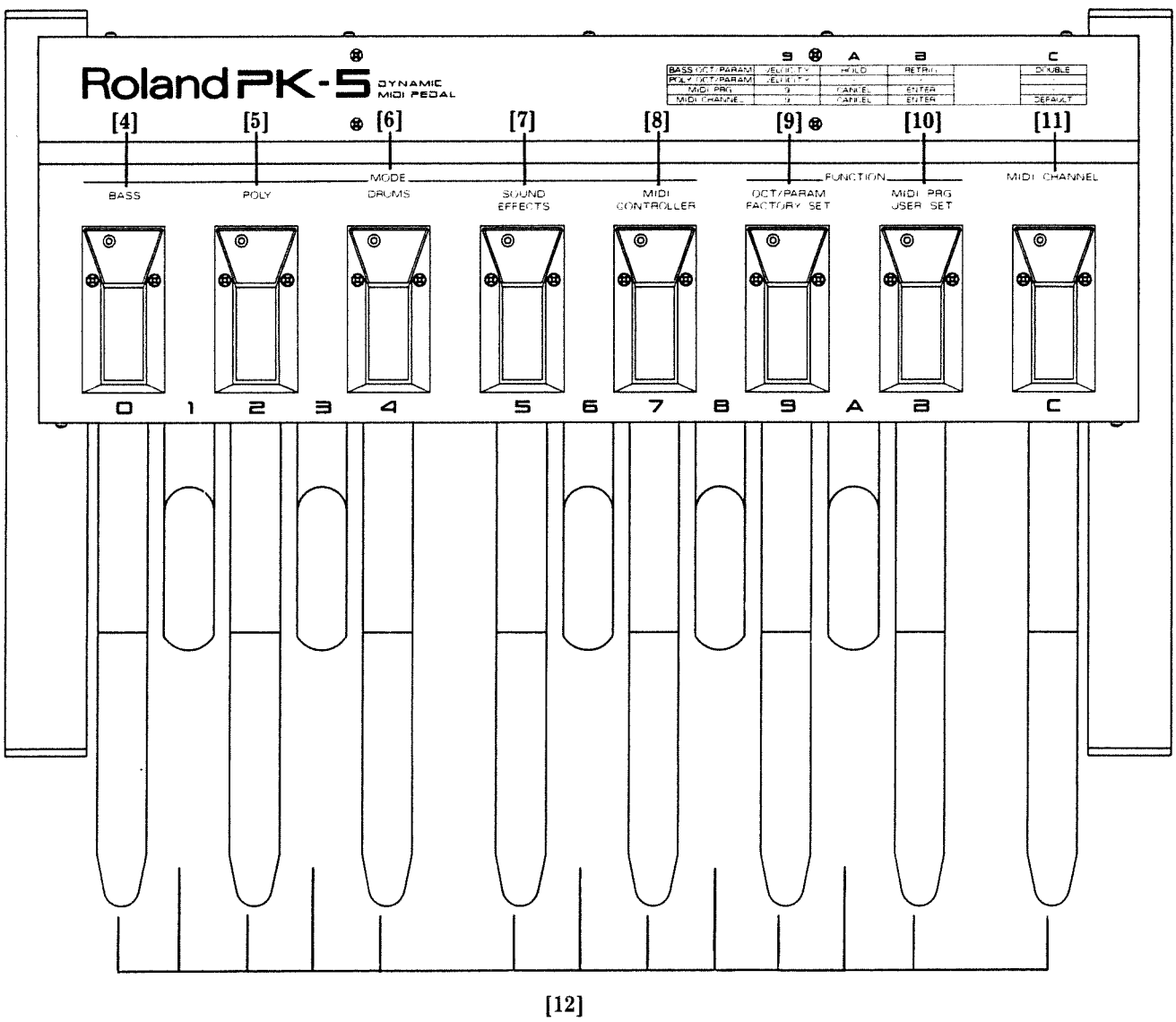
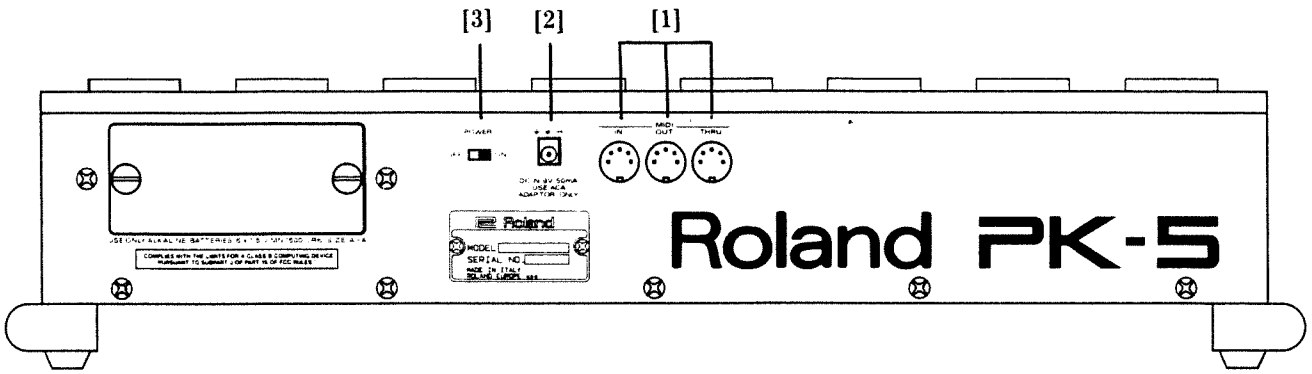

## U.S.A.

Roland Corp. US  
7200 Dominion Circle  
Los Angeles. CA. 90040-3647  
U.S.A.  
☎ (213) 685 - 5141

## CANADA

Roland Canada Music Ltd.  
(Head Office)  
13880 Mayfield Place  
Richmond B.C. V6V 2E4  
CANADA  
☎ (604) 270 - 6626

Roland Canada Music Ltd.  
3469 rue Ashby,  
St. Laurent,  
Quebec H4R 2C1  
CANADA  
☎ (514) 335 - 2009

Roland Canada Music Ltd.  
Unit B - 12. 1515 Matheson Blvd  
Mississauga, Ontario L4W 2P5  
CANADA  
☎ (416) 625 - 4880

## AUSTRALIA

Roland Corporation  
(Australia) Pty. Ltd.  
(Head Office)  
38 Campbell Avenue  
Dee Why West. NSW 2099  
AUSTRALIA  
☎ (02) 982 - 8266

Roland Corporation  
(Australia) Pty. Ltd.  
(Melbourne Office)  
50 Garden Street  
South Yarra, Victoria 3141  
AUSTRALIA  
☎ (03) 241 - 1254

## NEW ZEALAND

Roland Corporation (NZ) Ltd.  
97 Mt. Eden Road, Mt. Eden,  
Auckland 3  
NEW ZEALAND  
☎ (09) 398 - 715

## UNITED KINGDOM

Roland (UK) Ltd.  
Amalgamated Drive  
West Cross Centre, Brentford,  
Middlesex TW8 9EZ,  
UNITED KINGDOM  
☎ (01) 568 - 4578

## WEST GERMANY

Roland Elektronische  
Musikinstrumente  
Handelsgesellschaft mbH  
Oststrasse 96,  
D-2000 Norderstedt  
WEST GERMANY  
☎ 040/52 60 09 25

## BELGIUM / HOLLAND / LUXEMBOURG

Roland Benelex N.V.  
Houtstraat 1  
B - 2431 Oevel-Westerlo  
BELGIUM  
☎ 014 - 58 45 39

## DENMARK

Roland Scandinavia A/S  
Langebrogade 6, Postbox 1937  
DK - 1023 Copenhagen K.  
DENMARK  
☎ (01) 95 31 11

## SWEDEN

Roland Scandinavia A/S  
Swedish Sales Office  
DanvikCenter 28A, 2str.  
S - 131 30 Nacka.  
SWEDEN  
☎ 08 - 702 00 20

## NORWAY

Roland Scandinavia A/S  
(Division Norway)  
Lilleakerveien 2  
N - 0283 Oslo 2  
NORWAY  
☎ (02) 730074

## FINLAND

OY Musiikki Fazer Musik AB  
Takomotie 3  
00380 Helsinki 38  
FINLAND  
☎ 05 56551

## ITALY

Roland Italy S.p.A.  
Via delle Industrie, 8  
20020 Arese (MI)  
ITALY  
☎ 02 - 93581311

## SWITZERLAND

Roland CK (Switzerland) AG  
Hauptstrasse 21  
4456 Tenniken/Switzerland  
☎ 061 - 98 60 55  
Service: Musitronic AG,  
Gerberstrasse 5  
4410 Liestal/Switzerland  
☎ 061 - 921 68 82

## FRANCE

Musikengro  
102, Avenue Jean Jaures  
69367 Lyon Cedex 07  
FRANCE  
☎ (7) 858 - 54 60

Musikengro  
(Paris Office)  
Centre Region Parisienne  
41 rue Charles - Fourier  
94400 Vitry s/Seine  
FRANCE  
☎ (1) 4680 86 62

## SPAIN

Roland Electronics  
de España S.A.  
Bolivia 239  
08020 Barcelona  
SPAIN  
☎ 093 - 308 10 00

## AUSTRIA

E. Dematte & Co.  
Neu Rum Siemens Strasse 4  
A - 6021 Innsbruck Box 591  
AUSTRIA  
☎ 43 (05222) 63 4510

## GREECE

V. Dimitriadis & Co. Ltd.  
2 Fidiou Str.  
106 78 Athens  
GREECE  
☎ 3620130

## PORTUGAL

Casa Caius Instrumentos Musicais Lda.  
Rua de Santa Catarina 131  
Porto  
PORTUGAL  
☎ 2 - 38 44 56

## HUNGARY

Intermusica Ltd.  
Warehouse Area 'DEPO'  
Budapest P.O. Box 3  
2045 Torokbalimt  
Budapest  
HUNGARY  
☎ 1868905

|                |        |    |
|----------------|--------|----|
| English .....  | Page   | 7  |
| Deutsch .....  | Seite  | 21 |
| Français ..... | Page   | 35 |
| Italiano ..... | Pagina | 49 |
| 日本語 .....      | ページ    | 63 |



## CONTENTS

|  |    |
|--|----|
| <b>ROLAND WORLD DISTRIBUTORS</b> .....           | 4  |
| <b>FEATURES</b> .....                            | 8  |
| <b>ACCESSORIES SUPPLIED</b> .....                | 8  |
| <b>PANEL DESCRIPTION</b> .....                   | 8  |
| <b>IMPORTANT NOTES</b> .....                     | 9  |
| <b>THE CARE OF YOUR PK-5</b> .....               | 9  |
| <b>CONNECTIONS</b> .....                         | 9  |
| <b>OPERATION</b> .....                           | 10 |
| <b>MODE:</b>                                     |    |
| <b>Bass</b> .....                                | 10 |
| <b>Poly</b> .....                                | 12 |
| <b>Drums</b> .....                               | 13 |
| <b>Sound Effects</b> .....                       | 14 |
| <b>MIDI Controller</b> .....                     | 16 |
| <b>DEFAULT SETTING</b> .....                     | 17 |
| <b>DYNAMIC SENSITIVITY</b> .....                 | 18 |
| <b>MIDI CONTROLS</b> .....                       | 18 |
| <b>MIDI CONNECTIONS</b> .....                    | 18 |
| <b>IF YOUR INSTRUMENT FAILS TO OPERATE</b> ..... | 18 |
| <b>SPECIFICATIONS</b> .....                      | 19 |
| <b>MIDI IMPLEMENTATION CHART</b> .....           | 77 |

## FEATURES

- The PK-5 is a 13-pedal, monophonic/polyphonic, programmable pedalboard with dynamics.
- The PK-5 is not provided with an internal sound source system.
- LEDs provide information and directions to the player while programming the many features of the PK-5 making operation quicker and easier.
- MIDI connectors are provided for connecting other MIDI devices.

Thank you for purchasing the ROLAND PK-5 Dynamic MIDI Pedal.

The PK-5 is an easy-to-operate pedalboard that anyone can play and it gives you the benefit of ROLAND's superior digital technology.

## ACCESSORIES SUPPLIED

Supplied with your PK-5 are 6 alkaline batteries type MN 1500.

These will be found into the package.

The metal cover of the battery holder can be easily found on the rear part of the instrument.

- Open the cover and take the battery holder out of its location,
- Insert batteries in the appropriate holder.
- Place the holder into the appropriate location and close the metal cover.

## PANEL DESCRIPTION

- [1] MIDI sockets (IN/OUT/THRU)
- [2] AC ADAPTOR SOCKET (OPTIONAL)
- [3] POWER SWITCH

## MODE:

- [4] BASS
- [5] POLY
- [6] DRUMS
- [7] SOUND EFFECTS
- [8] CONTROLLER

## FUNCTION:

- [9] OCTAVE/PARAMETER  
FACTORY SET
- [10] PROGRAM CHANGE  
USER SET
- [11] MIDI CHANNEL
- [12] PEDALS



## **IMPORTANT NOTES**

- If you wish to use the PK-5 with external AC Adaptor type BOSS ACA (optional) please follow these precautions:
- The appropriate power supply for the instrument is shown on the AC ADAPTOR name plate. Please make sure that the line voltage in your country meets the requirements.
- Please do not use the same socket used for any noise generating device (such as a motor, variable lighting system).
- It is normal for this unit to become hot while being operated.
- If the unit is not to be used for a long period of time, unplug the external AC Adaptor from the AC line.
- Disconnect the AC Adaptor immediately in the event of an electrical storm
- Before setting up this keyboard with other MIDI devices, turn this keyboard off along with all other units.
- Be sure to connect the MIDI cables securely. If the MIDI cable is disconnected while the instrument is being played, various troubles will occur (e.g. the note may continue to sound).
- Static electricity may cause the built-in computer to malfunction. Should this occur, simply reset the instrument by turning the power switch off and then after a few seconds, back on.
- This instrument might not operate correctly if turned on immediately after being turned off. If this happens, simply turn it off and after a few seconds later, turn it on again.
- Operating the PK-5 near a neon light, fluorescent lamp, TV or CRT display, may cause noise interference. If so, change the position of the instrument.
- To avoid risk of electric shock, do not perform any servicing. Refer all servicing to qualified service personnel.

## **THE CARE OF YOUR PK-5**

To ensure the best use and full enjoyment of your PK-5, please read this guide carefully and thoroughly.

### **ROOM LOCATION**

Avoid using this instrument in excessive heat or humidity conditions or where it may be affected by direct sunlight or dust and avoid places subject to high vibrations.

### **CABINET CARE**

Use a soft dry cloth for dusting. To remove fingerprints or dulling film, use a soft cloth slightly dampened with water and a little mild detergent. Immediately wipe dry with a soft cloth. Do not use solvents such as paint thinners.

## **CONNECTIONS**

[1] MIDI Sockets (IN/OUT/THRU)

[2] AC Adaptor socket

To connect with household AC current, use only the optional AC ADAPTOR (model BOSS ACA)

[3] POWER ON/OFF switch

## OPERATION

After having inserted the six batteries into the appropriate holder, press the power On/Off switch [3] to operate the PK-5.

To use the PK-5 with the AC Adaptor (optional), connect the AC Adaptor to the 9 Volt DC IN socket [2], located on the rear panel of the instrument.

Make sure that the line voltage in your country meets the requirements. Connect the AC Adaptor to AC line. Press the power on/off switch [3] to activate the instrument.

### [4] BASS:

Pressing this selector [4] the pedalboard is enabled to play monophonically, that is only one note at a time can be played. The PK-5 has been conceived to be used with «E» series instruments, namely: E-20, E-5, E-10, E-30, PRO-E: consequently, its BASS section will be in default position when on MIDI channel no. 2, which is the same Manual Bass MIDI channel of the E-20, E-5, E-10, E-30, PRO-E.

When connecting via MIDI the pedalboard to anyone of these instruments, the Manual Bass mode of an «E» series instrument will be enabled to play.

When in Bass Pedalboard Mode [4], the following features in the FUNCTION section are enabled:

### [9] OCTAVE:

Nine different octave types can be selected by the pedals no. 0, 1, 2, 3, 4, 5, 6, 7, 8.

The octave no. 0 will represent the lowest octave type, and the octave no. 8 represents the highest octave type.

Pressing the OCTAVE selector [9], the corresponding led will light and show the OCTAVE function condition.

At this point the selection of anyone of the 9 octave types will be enabled, by pressing one of the pedals (0-8).

All the leds of the pedalboard will light simultaneously for a second, confirming that a selection has been made.

### [9] PARAMETER

Pressing the PARAMETER selector [9], the corresponding led will light to show the PARAMETER function condition:

When the PARAMETER function is enabled, the following parameters can be selected.

- VELOCITY (pedal marked by no. 9)
- HOLD (pedal marked by «A»)
- RETRIGGER (pedal marked by «B»)
- DOUBLE (pedal marked by «C»)

### VELOCITY:

This function can be selected by pressing the pedal marked by no. 9.

When the selection has been made, all the leds of the pedalboard will light simultaneously for a second.

If this parameter is «ON», the dynamic impulse sent by the pedalboard will have a range from 0 to 127; if this parameter is in «OFF» condition, the fixed value of 64 will be sent by the pedalboard.

To select the VELOCITY parameter in «OFF» condition, press the PARAMETER selector [9] and then press the pedal no. 9 once more.

All the leds of the pedalboard will light simultaneously for a second, confirming that the selection has been made.

### HOLD:

To select this function, press the pedal marked by «A» letter. All the leds of the pedalboard will light for a second, confirming that the selection has been made.

With the HOLD parameter in ON condition, the note pressed on the pedalboard will continue to sound.

Now it will be very easy to play a Bass part in a tied mode, as it is not necessary to continue to hold the pedal to obtain a suspended note.

To disable the note in «HOLD» condition, simply press the BASS selector [4].

To select the HOLD parameter in OFF condition, press the PARAMETER selector [9] and press the pedal marked by «A» letter once more. The leds of the pedalboard will light simultaneously for a second confirming that the selection has been made.

### **RETRIGGER:**

To select this function, press the pedal marked by «B» letter. The leds of the pedalboard will light simultaneously for a second, confirming that the selection has been made.

With this parameter in ON condition, some particular effects can be obtained.

When in Bass mode, the pedalboard is enabled to play monophonically: pressing two pedals simultaneously, only the last note pressed will sound. When this note is released, the note previously pressed will sound, so a pleasant effect of alternance will be obtained.

To select the RETRIGGER parameter in OFF condition, press the PARAMETER selector [9], then press the pedal marked by «B» letter once more. All the leds of the pedalboard will light simultaneously for a second, confirming that the selection has been made.

### **DOUBLE:**

To select this function, press the pedal marked by «C» letter. The leds of the pedalboard will light simultaneously for a second, confirming that the selection has been made.

With this parameter in ON condition, even if a single note is played, two sounds will be heard: the first one is the note played, the second one is the same note, but transposed of an octave higher.

To select the DOUBLE parameter in OFF condition, press the PARAMETER selector [9] and press the pedal marked by «C» letter once more. The leds of the pedalboard will light simultaneously for a second, confirming that the selection has been made.

### **[10] MIDI PROGRAM CHANGE:**

To send a program change number, press the MIDI PROGRAM CHANGE selector [10]; the corresponding led will light.

By pressing the pedals, compose the number you wish to send (e.g. to send the program change no. 123, press the pedals no. 1, 2 and 3 in sequence). Then press the pedal marked by «B» letter (ENTER) to confirm the operation. The leds of the pedalboard will light simultaneously for a second, to confirm that the selection has been made.

If a program change number is erroneously selected, press the pedal marked by «A» letter (CANCEL), to cancel the operation.

If you wish to send again the program change number previously selected, simply press the MIDI PROGRAM CHANGE selector [10] and the pedal marked by «B» letter (ENTER). The leds of the pedalboard will light simultaneously for a second, confirming that the selection has been made.

If a program change number higher than 128 is erroneously selected, the pedalboard will exit automatically this function when the «B» pedal (ENTER) is pressed.

### **[11] MIDI CHANNEL**

To select anyone of the MIDI channels (1-16), press the MIDI CHANNEL selection selector [11] and the corresponding led will light.

By pressing the pedals, compose the number of the MIDI channel you wish to send (e.g. to send the MIDI channel no. 15, press the pedals no. 1 and 5 in sequence). Then press the pedal marked by «B» letter (ENTER) to confirm the operation. The leds of the pedalboard will light simultaneously for a second, confirming that the selection has been made.

If a number is erroneously selected, press the pedal marked by «A» letter (CANCEL), to cancel the operation.

If you wish to select the default MIDI channel (the number 2 when in BASS mode), simply press the MIDI CHANNEL selector [11] and the pedal marked by «C» letter (DEFAULT). The leds of the pedalboard will light simultaneously for a second, confirming that the selection has been made.

If a MIDI channel number higher than 16 is erroneously selected, the pedalboard will exit automatically this function when the «B» pedal (ENTER) is pressed.

## **[5] POLY:**

Pressing this selector [5] the pedalboard will sound poliphonically (that is more notes can be played simultaneously). Connecting the PK-5 to an «E» series instrument, the Poly mode enables the chords to be played by the pedalboard, after having set the Chord Intelligence function of the PRO-E, E-30, etc. in ON position in order to make the operation easier.

The PK-5 is preset for this function, being its default POLY section on MIDI channel no. 1, which is the same MIDI channel of the PRO-E, E-30, etc. «Note To Arranger».

When in POLY pedalboard mode [5], the following functions are enabled in the FUNCTION section:

### **[9] OCTAVE**

A range of 9 different octave types can be selected by no. 1, 2, 3, 4, 5, 6, 7, 8 pedals.

The octave no. «0» will be the lowest octave, the octave no. «8» will indicate the highest octave.

Pressing the OCTAVE selector [9], the corresponding led will light to show that the OCTAVE function has been enabled.

At this point anyone of the 9 octave types can be selected by pressing one of the pedals (0-8). All the leds of the pedalboard will light simultaneously for a second, confirming that the selection has been made.

### **[9] PARAMETER**

Pressing the PARAMETER selector [9] the corresponding led will light to show that the PARAMETER function has been enabled.

With the PARAMETER function enabled, the following selections can be made:

#### **VELOCITY:**

To select this function, press the pedal marked by no. 9. All the leds of the pedalboard will light simultaneously for a second confirming that the selection has been made.

When this parameter is in ON condition, the dynamic value sent by the pedal will have a range from 0 to 127 while when this parameter is in OFF condition, the fixed dynamic value of 64 will be sent.

To select the VELOCITY parameter in OFF condition, simply press the PARAMETER selector [9] and then press the pedal no. 9 once more. All the leds of the pedalboard will light simultaneously for a second, confirming that the selection has been made.

### **[10] MIDI PROGRAM CHANGE**

A MIDI program change number can be sent by pressing the MIDI PROGRAM CHANGE selector [10], the corresponding led will light.

By pressing the pedals, compose the number of the PROGRAM CHANGE you wish to send (e.g. to send the program change no. 105, press the pedals no. 1, 0 and 5 in sequence). Then press the pedal marked by «B» letter (ENTER) to confirm the operation. The leds of the pedalboard will light simultaneously for a second, confirming that the selection has been made.

If a number is erroneously selected, press the pedal marked by «A» letter (CANCEL), to cancel to operation.

If you wish to send again the program change number previously selected, simply press the MIDI PROGRAM CHANGE selector [10] and the pedal marked by «B» letter (ENTER).

The leds of the pedalboard will light simultaneously for a second, confirming that the selection has been made.

If a program change number higher than 128 is erroneously selected, the pedalboard will exit automatically this function when the «B» pedal (ENTER) is pressed.

### **[11] MIDI CHANNEL**

To select anyone of the MIDI channels (1-16), press the MIDI CHANNEL selector [11]; the corresponding led will light.

By pressing the pedals, compose the number of the MIDI channel you wish to send (e.g. to send the MIDI channel no. 12, press the pedals no. 1, and 2 in sequence). Then press the pedal marked by «B» letter (ENTER) to confirm the operation. The leds of the pedalboard will light simultaneously for a second, confirming that the selection has been made.

If a number is erroneously selected, press the pedal marked by «A» letter (CANCEL), to cancel the operation.

If you wish to select the default MIDI channel (the number 1 when in POLY mode), simply press the MIDI CHANNEL selector [11] and the pedal marked by «C» letter (DEFAULT).

The leds of the pedalboard will light simultaneously for a second, confirming that the selection has been made.

If a MIDI channel number higher than 16 is erroneously selected, the pedalboard will exit automatically this function when the «B» pedal (ENTER) is pressed.

## [6] DRUMS:

Pressing this selector [6] the pedalboard will sound in DRUMS Mode.

The PK-5 has been conceived to be used with «E» series instruments: consequently, the DRUMS section will be in default position when on MIDI channel no. 10, that is the same Manual Drums MIDI channel of the E-20, E-5, E-10, E-30, PRO-E.

When connecting the pedalboard via MIDI to anyone of these instruments, the Manual Drums mode of an «E» series instrument will be enabled to play automatically, without performing complicated operations.

When in Drums Pedalboard Mode [6], the following features in the FUNCTION section are enabled:

## [9] FACTORY SET

Pressing the FACTORY SET selector [9] (the corresponding led lights), 13 drum sounds will be available; they represent the FACTORY SET.

The FACTORY SET can't be programmed by the User.

### FACTORY SET:

| Pedal no. | MIDI note | Drums instruments |
|-----------|-----------|-------------------|
| 0         | C 2 36    | Acou BD           |
| 1         | C# 2 37   | Rim Shot          |
| 2         | D 2 38    | Acou SD           |
| 3         | D# 2 39   | Hand Clap         |
| 4         | E 2 40    | Elec SD           |
| 5         | F 2 41    | Acou Low Tom      |
| 6         | F# 2 42   | Clsd Hi Hat       |
| 7         | A 2 45    | Acou Mid Tom      |
| 8         | G# 2 44   | Open Hi Hat 2     |
| 9         | C 3 48    | Acou Hi Tom       |
| A         | A# 2 46   | Open Hi Hat 1     |
| B         | C# 3 49   | Crash Cym         |
| C         | D# 3 51   | Ride Cym          |

## [10] USER SET

Pressing the USER SET selector [10] (the corresponding led lights), 13 drum sounds will be available; they represent the USER SET.

The USER SET can be programmed by the User.

| Pedal no. | MIDI note | Drums instruments |
|-----------|-----------|-------------------|
| 0         | E 4 64    | Low Conga         |
| 1         | D# 4 63   | High Conga        |
| 2         | D 4 62    | Mt High Conga     |
| 3         | C# 4 61   | Low Bongo         |
| 4         | C 4 60    | High Bongo        |
| 5         | F# 4 66   | Low Timbale       |
| 6         | F 4 65    | High Timbale      |
| 7         | F# 3 54   | Tamburine         |
| 8         | A 4 69    | Cabasa            |
| 9         | G# 4 68   | Low Agogo         |
| A         | G 4 67    | High Agogo        |
| B         | B 4 71    | Samba Whis S      |
| C         | A 3 73    | Quijada           |

## PROGRAMMING THE USER SET

Follow this procedure to program the USER SET:

- Connect the MIDI OUT of your keyboard (PRO-E, E-30, etc.) to the MIDI IN of the PK-5.
- Select the same MIDI channel in the keyboard and the PK-5 (MIDI channel no. 10).
- Select the DRUMS [6] pedalboard mode in the PK-5.
- Press and hold for two seconds the USER SET selector [10]; after that, the corresponding led will begin to flash, showing that the instrument is in ready condition for programming.
- Press and hold (from your keyboard), the Drums note you wish to memorize into the USER SET.
- Press (on the PK-5) the pedal into which you wish to memorize the drums note.

At this point release the note played from your keyboard.

All the leds of the pedalboard will light simultaneously for a second, confirming that the programming has been effected.

Repeat the procedure for programming the whole USER SET.

## [11] MIDI CHANNEL

To select the MIDI Channels (1-16), press the MIDI CHANNEL selector [11]: the corresponding led will light.

By pressing the pedals, compose the number of the MIDI channel you wish to send (e.g. to send the MIDI channel no. 16, press the pedals no. 1 and 6 in sequence). Then press the pedal marked by «B» letter (ENTER) to confirm the operation. The leds of the pedalboard will light simultaneously for a second, confirming that the selection has been made.

If a number is erroneously selected, press the pedal marked by «A» letter (CANCEL), to cancel the operation.

If you wish to select the default MIDI channel (the number 10 when in DRUMS condition), simply press the MIDI CHANNEL selector [11] and the pedal marked by «C» letter (DEFAULT).

The leds of the pedalboard will light simultaneously for a second confirming that the selection has been made.

If a MIDI channel number higher than 16 is erroneously selected, the pedalboard will exit automatically this function when the «B» pedal (ENTER) is pressed.

## [7] SOUND EFFECTS:

Pressing the selector [7] the pedalboard is enabled to play in the SOUND EFFECTS mode.

The PK-5 has been conceived to be used with «E» series instruments, such as the E-30, PRO-E, etc.; consequently, the SOUND EFFECTS mode will be in default position when on MIDI channel no. 11, that is the same Sound Effects MIDI channel of the E-30, PRO-E, etc.

When connecting the pedalboard via MIDI to anyone of these instruments, the Sound Effects mode of an «E» series instrument will be enabled to play, without performing complicated operations.

When in SOUND EFFECTS Pedalboard Mode [7] the following features in the FUNCTION section are enabled:

## [9] FACTORY SET

Pressing the FACTORY SET selector [9] (the corresponding led lights), 13 Sound Effects sounds will be available: they represent the FACTORY SET.

The FACTORY SET can't be programmed by the User.

FACTORY SET:

| Pedal no. | MIDI note | Drums instruments |
|-----------|-----------|-------------------|
| 0         | G 7 103   | Rain              |
| 1         | G# 7 104  | Thunder           |
| 2         | A# 7 106  | Waves             |
| 3         | B 7 107   | Stream            |
| 4         | E 5 76    | Laughing          |
| 5         | F 5 77    | Screaming         |
| 6         | A# 5 82   | Applause          |
| 7         | A 6 93    | Jet               |
| 8         | G# 6 92   | Train             |
| 9         | A# 6 94   | Helicopter        |
| A         | D 6 86    | Windchime         |
| B         | D# 8 111  | Thriller          |
| C         | E# 8 112  | Wonderland        |

## [10] USER SET

Pressing the USER SET selector [10] (the corresponding led lights), 13 Sound Effects sounds will be available, they represent the USER SET.

The USER SET can be programmed by the User.

| Pedal no. | MIDI note | Drums instruments |
|-----------|-----------|-------------------|
| 0         | F# 7 102  | Birds             |
| 1         | E 7 100   | Dog               |
| 2         | G 5 79    | Heartbeat         |
| 3         | A 5 81    | Footstep 2        |
| 4         | B 5 83    | Creaking          |
| 5         | C 6 84    | Door              |
| 6         | C# 6 85   | Scratch           |
| 7         | D# 6 87   | Engine            |
| 8         | E 6 88    | Car stop          |
| 9         | F 6 89    | Car pass          |
| A         | G 6 91    | Siren             |
| B         | C 7 96    | Pistol            |
| C         | A 7 105   | Wind              |

## PROGRAMMING THE USER SET

Follow this procedure to program the USER SET:

- Connect the MIDI OUT of your keyboard (PRO-E, E-30, etc.) to the MIDI IN of the PK-5.
- Select the same MIDI channel in the keyboard and the PK-5 (MIDI channel no. 11).
- Select the SOUND EFFECTS pedalboard mode [7] in the PK-5.
- Press and hold for two seconds the USER SET selector [10]; after that, the corresponding led will begin to flash, showing that the instrument is in ready condition for programming.
- Press and hold (from your keyboard), the Sound Effects notes you wish to memorize into the USER SET.
- Press (on the PK-5) the pedal into which you wish to memorize the Sound Effects notes.

At this point release the note played from your keyboard.

All the leds of the pedalboard will light simultaneously for a second, confirming that the programming has been effected.

Repeat the procedure for programming the whole USER SET.

## [11] MIDI CHANNEL

To select the MIDI Channels (1-16), press the MIDI CHANNEL selector [11]: the corresponding led will light.

By pressing the pedals, compose the number of the MIDI channel you wish to send (e.g. to send the MIDI channel no. 16, press the pedals no. 1 and 6 in sequence). Then press the pedal marked by «B» letter (ENTER) to confirm the operation. The leds of the pedalboard will light simultaneously for a second, confirming that the selection has been made.

If a number is erroneously selected, press the pedal marked by «A» letter (CANCEL), to cancel the operation.

If you wish to select the default MIDI channel (the number 11 when in SOUND EFFECTS condition), simply press the MIDI CHANNEL selector [11] and the pedal marked by «C» letter (DEFAULT).

The leds of the pedalboard will light simultaneously for a second confirming that the selection has been made.

If a MIDI channel number higher than 16 is erroneously selected, the pedalboard will exit automatically this function when the «B» pedal (ENTER) is pressed.

## [8] MIDI CONTROLLER:

Pressing this selector [8], the pedalboard is enabled to send MIDI controls.

The PK-5 has been conceived to be used with some «E» series instruments, such as the E-30, PRO-E, etc., consequently, the MIDI CONTROLLER section in the FACTORY SET will be in default position when on MIDI channel no. 10, that is the same Style Program Change MIDI channel of the E-30, PRO-E, etc.

In the USER SET, the MIDI CONTROLLER section is in default setting on MIDI channel no. 1, and it can be multichannel, that is MIDI messages with different MIDI channels can be memorized.

Connecting the PK-5 via MIDI to anyone of «E» series instruments, the pedalboard can be used to enable the Drums Start/Stop, Fill in to Variation, Fill in to Original, Break Mute, Intro and Ending without performing complicated operations.

When in MIDI CONTROLLER Pedalboard Mode [8] the following features in the FUNCTION section are enabled:

## [9] FACTORY SET

Pressing the FACTORY SET selector [9] (the corresponding led lights), the following MIDI controls will be available:

- Start
- Fill in to Variation
- Fill in to Original
- Break Mute
- Intro
- Ending
- Stop

The FACTORY SET can't be programmed by the User.

## FACTORY SET:

| Pedal no. | MIDI Message | Midi Controller      |
|-----------|--------------|----------------------|
| 0         | FA           | Start                |
| 1         | PG. 81       | Fill in to Variation |
| 2         |              |                      |
| 3         | PG. 82       | Fill in to Original  |
| 4         |              |                      |
| 5         |              |                      |
| 6         | PG. 85       | Break Mute           |
| 7         |              |                      |
| 8         | FA + PG. 83  | Intro                |
| 9         |              |                      |
| A         | PG. 84       | Ending               |
| B         |              |                      |
| C         | FC           | Stop                 |

## [11] MIDI CHANNEL

To select the MIDI Channels (1-16), press the MIDI CHANNEL selector [11]: the corresponding led will light.

By pressing the pedals, compose the number of the MIDI channel you wish to send (e.g. to send the MIDI channel no. 16, press the pedals no. 1 and 6 in sequence). Then press the pedal marked by «B» letter (ENTER) to confirm the operation. The leds of the pedalboard will light simultaneously for a second, confirming that the selection has been made.

If a number is erroneously selected, press the pedal marked by «A» letter (CANCEL), to cancel the operation.

If you wish to select the default MIDI channel (the number 10 when in MIDI CONTROLLER mode), (FACTORY SET) simply press the MIDI CHANNEL selector [11] and the pedal marked by «C» letter (DEFAULT).

The leds of the pedal will light simultaneously for a second confirming that the selection has been made.

If a MIDI channel number higher than 16 is erroneously selected, the pedal will exit automatically this function when the «B» pedal (ENTER) is pressed.

\* The MIDI channel change is operating only in the FACTORY SET mode, being the USER SET function multichannel.



## [10] USER SET

Pressing the USER SET selector [10] (the corresponding led lights) the following MIDI Controls are available:

| Pedal no. | MIDI Message | Midi Controller |
|-----------|--------------|-----------------|
| 0         | CC 93        | Chorus ON       |
| 1         | CC 93        | Chorus OFF      |
| 2         | CC 92        | Tremolo ON      |
| 3         | CC 92        | Tremolo OFF     |
| 4         | CC 07        | Volume 00       |
| 5         | CC 07        | Volume 30       |
| 6         | CC 07        | Volume 45       |
| 7         | CC 07        | Volume 64       |
| 8         | CC 07        | Volume 80       |
| 9         | CC 07        | Volume 95       |
| A         | CC 07        | Volume 110      |
| B         | CC 07        | Volume 127      |
| C         | CC 64        | Sustain ON/OFF  |

The USER SET [10] can be programmed by the User.

## PROGRAMMING THE USER SET

Follow this procedure to program the USER SET:

- Connect the MIDI OUT of your keyboard (PRO-E, E-30, etc.) to the MIDI IN of the PK-5.
- Select the same MIDI CONTROLLER pedalboard mode [8] on the PK-5.
- Press and hold for two seconds the USER SET selector [10]; after that, the corresponding led will begin to flash, showing that the instrument is in ready condition for programming.
- Send the MIDI data you wish to memorize in the USER SET to the PK-5, in the MIDI channel in which you wish transmit them.
- Press (from the PK-5) the pedal into which you wish to memorize the MIDI data received.

All the leds of the pedalboard will light simultaneously for a second, confirming that the programming has been effected.

Repeat the procedure for programming the whole USER SET.

At this point release the note played on your keyboard.

Note: While programming, the pedalboard memorizes the last MIDI data received only.

Be sure that the data you wish to hold are the only ones or the last sent to the pedalboard.

## DEFAULT SETTINGS

The PK-5 will always select the following features when it is turned on (unless programmed in a different way):

### BASS

- MIDI Channel 2
- Velocity ON
- Hold OFF
- Retrigger ON
- Double OFF

### POLY

- MIDI Channel 1
- Velocity ON

### DRUMS

MIDI Channel:

- Factory set ch. MIDI 10
- User set ch. MIDI 10

### SOUND EFFECTS

MIDI Channel:

- Factory set ch. MIDI 11
- User set ch. MIDI 11

### MIDI CONTROLLER

MIDI Channel:

- Factory set ch. MIDI 10
- User set ch. MIDI 1

## RESETTING DEFAULT VALUES:

To reset the default values when in anyone of the pedalboard modes, simply turn the instrument on while pressing the mode selector [9].

To reset the default values of all the pedalboard modes, (BASS, POLY, DRUMS, SOUND EFFECTS, MIDI CONTROLLER), simply turn the instrument on while pressing the selector [9].

## DYNAMIC SENSITIVITY:

When the instrument is turned on, 13 different types of DYNAMIC SENSITIVITY curves can be selected.

A single dynamic curve is assigned to each pedal; to recall it, simply press one of the 13 pedals, then turn the instrument on.

The curve with the highest value of dynamic sensitivity is assigned to the pedal no. 0, on the contrary the curve with the lowest value of dynamic sensitivity is assigned to the pedal marked by «C» letter.

The intermediary values of dynamic sensitivity are assigned to the pedals from «O» to «C».

The last dynamic curve selected will be remembered when the instrument is turned off.

## MIDI CONTROL

M.I.D.I. is the acronym for Musical Instrument Digital Interface.

MIDI is a standardized interface by which all digital musical instruments also equipped with MIDI connections can exchange data.

This means that your PK-5 can be used as a MIDI control pedalboard to control other MIDI devices («E» series arrangers, synthesizers, expanders, etc.).

## MIDI CONNECTIONS:

There are three MIDI sockets on the rear panel of the PK-5.

— MIDI IN socket

Use this socket for feeding MIDI signals from an external MIDI device to the PK-5; use this socket for programming the PK-5 USER SET in the DRUMS, SOUND EFFECTS, MIDI CONTROLLER pedalboard modes.

— MIDI OUT socket:

Use this socket for sending MIDI signals from the PK-5 to control external MIDI devices (PRO-E, E-30 etc.).

— MIDI THRU socket:

The exact copy of the signal fed into the MIDI IN is sent out through this socket.

\* The signal fed into MIDI IN is mixed with the Midi messages of the pedalboard and both are sent to MIDI OUT (MIDI SOFT THRU)

\*\* When receiving an Exclusive System, the pedalboard will be disabled until the message is completely received.

## IF YOUR PK-5 FAILS TO OPERATE

Make sure that the 6 Alkaline Batteries (MN 1500) are not below their charge limits.

\* When using the optional AC Adaptor, make sure that the AC Adaptor cord is firmly plugged into the socket on the rear panel [2]. Make sure that the AC cord of the ADAPTOR is firmly plugged into the AC wall outlet. Also check that the AC wall outlet is not faulty. Plug in a lamp or radio to test the wall outlet.

\* Be sure the ON/OFF switch [3] (located on the rear panel) is ON.

\* In the event the instrument is still inoperable, your Roland technician or dealer is best qualified to provide you with competent service. Do not attempt any adjustments or repairs by yourself.

## **SPECIFICATIONS**

### **PEDALBOARD:**

- 13 KEY POLYPHONIC/MONOPHONIC PEDALBOARD
- DYNAMICS (13 different types of dynamic curves which can be selected when the instrument is turned on)
- DYNAMIC ON/OFF condition
- MIDI Soft Thru (the messages received by MIDI IN are sent by MIDI OUT)

### **MODE:**

- BASS (Monophonic)
- POLY
- DRUMS
- SOUND EFFECTS
- MIDI CONTROLLER

### **FUNCTIONS:**

- OCT/PARAMETER  
FACTORY SET
- PROGRAM CHANGE  
USER SET

### **MIDI CHANNEL**

#### **FUNCTIONS:**

##### **BASS:**

- Octave (0-8)
- Parameter (Velocity - Hold - Retrigger - Double Octave)
- Program change numbers (1-128)
- MIDI Channel (1-16)

##### **POLY:**

- Octave (0-8)
- Parameter (Velocity)
- Program change numbers (1-128)
- MIDI Channel (1-16)

##### **DRUMS:**

- Factory Set
- User Set (Programmable)
- MIDI Channel (1-16)

##### **SOUND EFFECTS:**

- Factory Set
- User Set (Programmable)
- MIDI Channel (1-16)

##### **MIDI CONTROLLER:**

- Factory Set
- User Set (Programmable)
- MIDI Channel (1-16)

### **REAR PANEL:**

- AC Adaptor socket
- Power ON/OFF switch
- MIDI sockets (THRU/OUT/IN)

### **DIMENSIONS:**

425 × 560 × 120 mm.

### **WEIGHT:**

Kg. 8

### **OPTIONS:**

BOSS AC Adaptor ACA 220 (9V/300 mA) for 220 V connection  
BOSS AC Adaptor ACA 240 (9V/100 mA) for 240 V connection  
BOSS AC Adaptor ACA 120 (9V/200 mA) for 117 V connection  
BOSS AC Adaptor ACA 100 (9V/150 mA) for 100 V connection





 Roland®

---

**26048193**

UPC

26048193



10981

**Roland**