

MIXING AMPLIFIER

PA-80

OWNER'S MANUAL

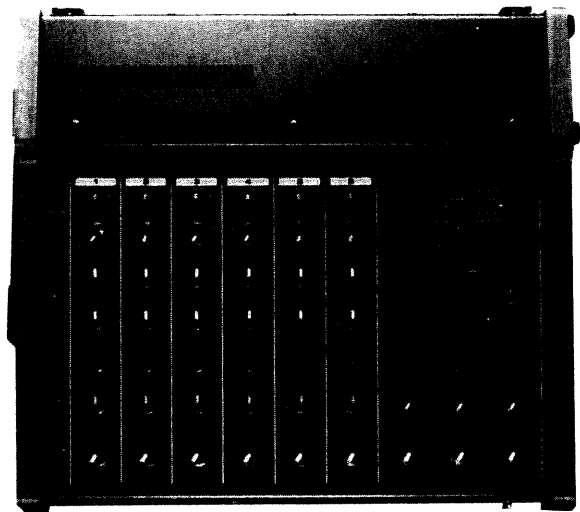

Features

- Six inputs, two outputs.
Built-in power amplifier: 30 watts (8 Ω) per channel (40 watts per channel when using four speakers).
- Attenuator controls for matching input levels. Overload indicators for each input.
- PHONO IN jacks for direct connection of player.
AUX IN jacks for connecting a tape recorder or sub-mixer.
- MASTER OUT and BUSS IN jacks for stacking.
- REC OUT jacks for recording.
- Peak indicating bar LED display.
- Built-in reverberation unit.
- Headphone monitor circuit.

THE CONTROLS AND THEIR FUNCTIONS

CONTROL PANEL

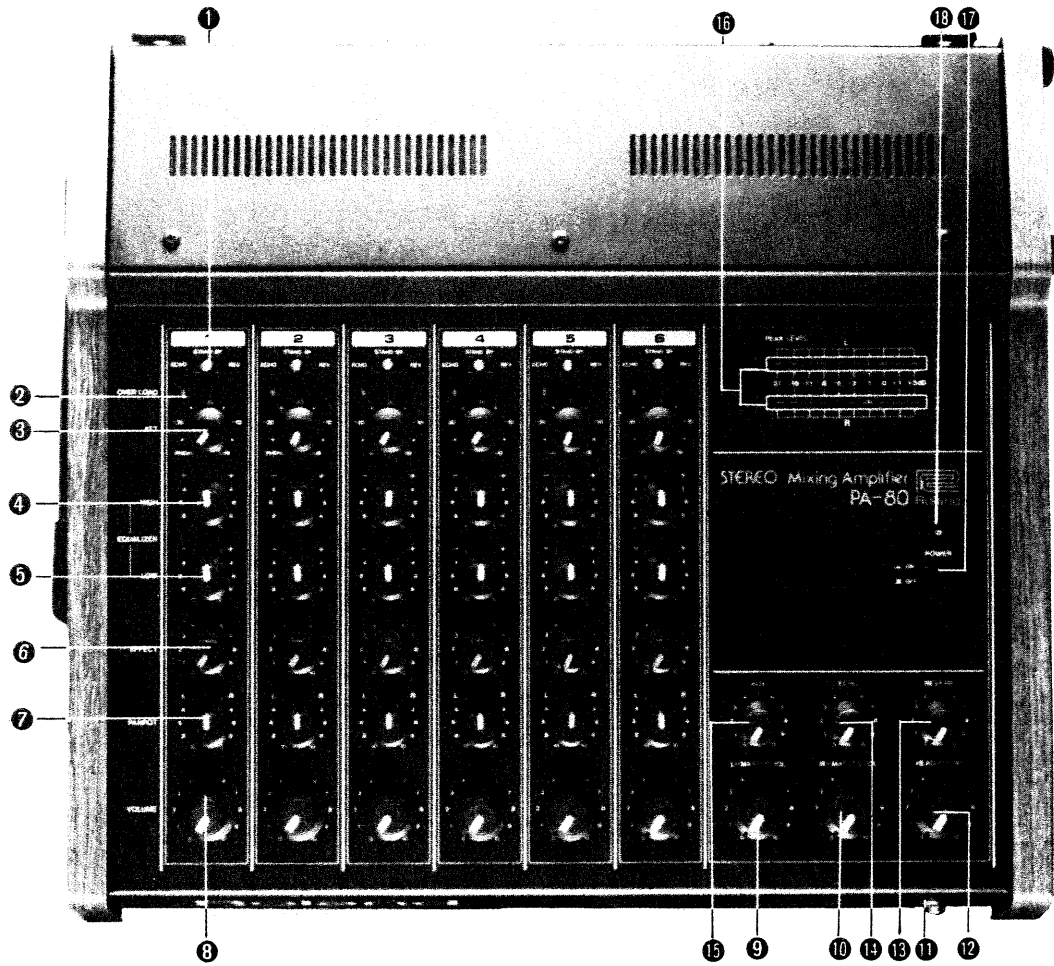

REAR PANEL

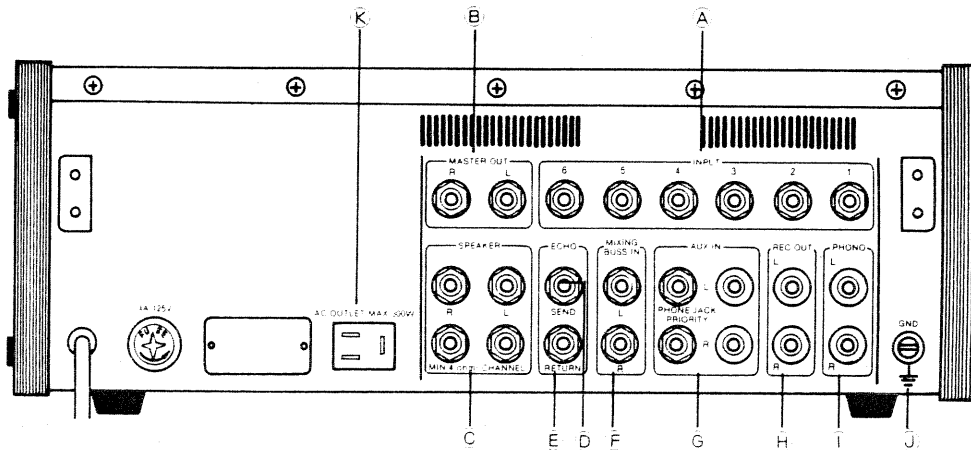

CONTROL PANEL

① STANDBY Switch

Controls the ON/OFF function of each channel, and determines the effect for the channel. At ECHO or REVERB, the channel is ON.

② OVERLOAD Indicator

③ ATTENUATOR Control

Each input channel is equipped with a preamp circuit with a normal input level of -50dBm (microphone level). The ATTENUATOR control ③ allows connection of high level inputs.

When the OVERLOAD indicator ② lights, the input level is too high and distortion may result.

Turning the Channel 1 or 2 ATTENUATOR controls ③ fully counterclockwise activates the record player equalization circuits.

④ EQUALIZER: HIGH Control

⑤ EQUALIZER: LOW Control

Tone controls for the input channels.

⑥ EFFECT Volume

Determines the send level to the effect device selected with the STANDBY switch ①. This output is taken after the VOLUME control ⑧ which means that the send level is affected by changes in the VOLUME control ⑧.

⑦ PANPOT Control

Determines the position of the sound in the stereo field.

⑧ Channel VOLUME Control

Determines the input level for each channel.

⑨ MASTER VOLUME Control (left)

⑩ MASTER VOLUME Control (right)

Controls the overall output level at the speakers and at the MASTER OUTPUT jacks B.

⑪ HEADPHONE Jack

⑫ HEADPHONE VOLUME Control

⑬ REVERB VOLUME Control

⑭ ECHO VOLUME Control

⑮ AUXILIARY VOLUME Control

These controls control the input level from the internal reverberation unit, external echo machine, and auxiliary device.

⑯ PEAK LEVEL Indicators

Shows the output level of the PA-80.

⑰ POWER Switch

⑱ PILOT Lamp

REAR PANEL

A INPUT Jacks

For inputs of -50dBm to -10dBm .

B MASTER OUTPUT Jacks

For stacking mixers or for feeding an external amplifier. The output level is controlled by the MASTER VOLUME controls ⑨ ⑩.

C SPEAKER Jacks

Two speakers can be connected to each output channel as long as the total impedance for each channel is over 4Ω .

D ECHO SEND Jack

E ECHO RETURN Jack

ECHO

SEND—[INPUT OUTPUT]—RETURN

F MIXING BUSS IN Jacks

Direct line level connections to the mixing portion of the system. A second mixer can be connected here to increase the total number of channels available for mixing.

G AUX INPUT Jacks

A line level buss input whose input level is controlled by the AUXILIARY VOLUME Control ⑮.

When the pin jacks and phone jacks are used simultaneously, the phone jacks have priority.

H RECORDING OUT Jacks

For connection to tape recorder LINE IN jacks.

The output level at these jacks is not affected by the MASTER VOLUME controls ⑨ ⑩.

I PHONO Jacks

J GROUND Terminal

For record player grounding. Also for making common ground connections to other equipment when needed to prevent hum.

K AC OUTLET

Maximum output: 300 watts; not affected by POWER switch ⑰.

CONNECTIONS

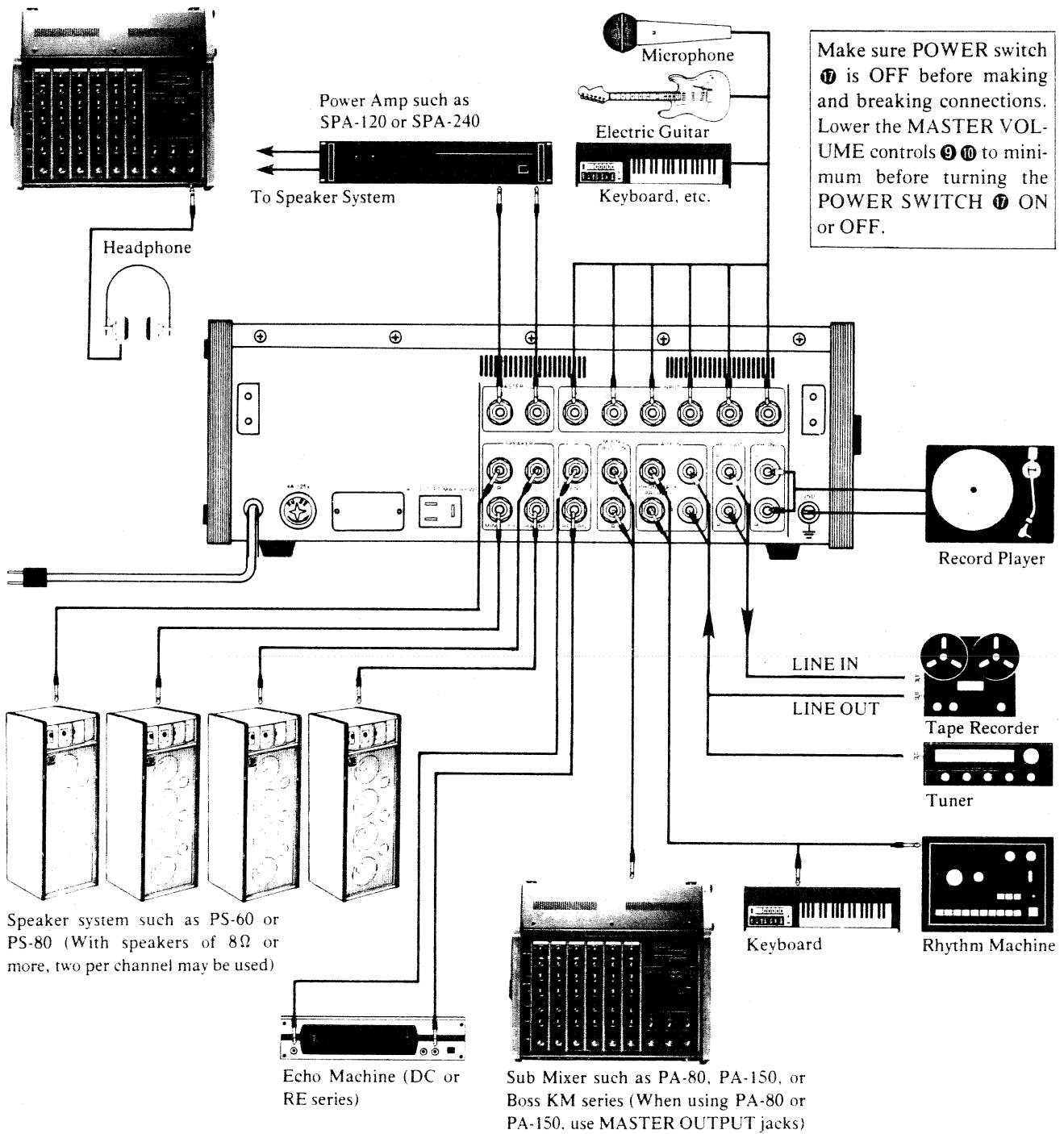

OPERATION

Mixing with a microphone or instruments

- 1** After making the necessary connections, turn all the knobs to either 0 or 0dB. Set the STAND BY switch to STAND BY.

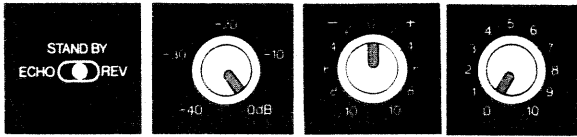

- 2** Turn on the power switch.

- 3** Set the STAND BY switch of the channel to be used to either ECHO or REV.



- 4** With the connected instrument in performance, after the Overload Indicator has lighted up, turn the ATTENUATOR control to the left until the overload indicator goes off. Then from that level, further turn to the left to set at approximately -10dB.

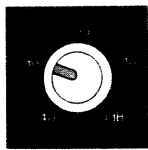

- 5** Set the channel volume to "5".

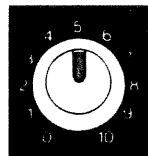

- 6** Set the master volume for the "L" "R" channels to an appropriate level. For this, if the level meter lights up till 0dB, the output is rating (125W/4Ω).

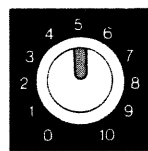

- 7** While emitting a sound, adjust the tone quality (HIGH, LOW) you want to obtain with each channel.

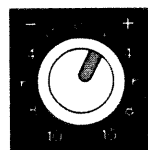

- 8** If the volume balance of each channel is not appropriate, make adjustments with the channel volume knobs.

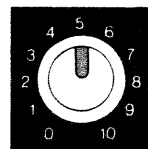

- 9** Use each panpot knob to shift the sound position from and to the left or right.

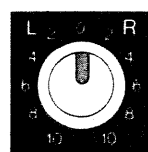

FOR THE ECHO OR REVERBERATION EFFECT

- 10** Set the STAND BY switch of the channel that is connected to either ECHO or REV.



If an echo machine is not connected, even if the STAND BY switch is set to ECHO, the echo effect will not be obtained.

- 11** For the echo, set the echo volume and the effect volume of the channel where you want to give an echo effect to an appropriate level while emitting sound.

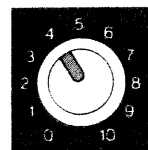

- 12** For reverberation, adjust the reverberation volume and the effect volume of the channel where you want to give the reverberation effect to an appropriate level while emitting sound.

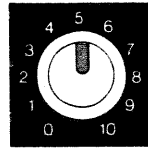

FOR PLAYING RECORDS

- 13** Set the first and second channels to either ECHO or REV and set the channel volume to "0".



- 14** Turn the attenuator of the first and second channel to PHONO.



- 15** Adjust the channel volumes and master volumes of the first and second channels to appropriate levels.

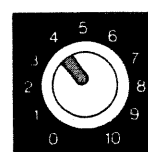

- 16** For stereo, set the panpot of channel 1 to "L" and for channel 2, "R". For monaural, set both the channel one and two panpots to "0".

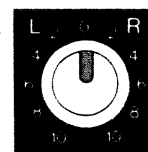

If the earth line of the record player and the EARTH jack of the PA-80 are not connected, there may be a humming noise.

TO REPLAY WHAT HAS BEEN RECORDED

- 17** Connect a tape deck according to the hookup instructions. Always record with the AUX volume at "0". For this, a recording can be made with the master volume lowered.

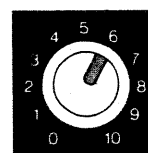

- 18** For replay, set the AUX volume and the master volume to an appropriate level. *With the PA-80, sound cannot be monitored during recording.

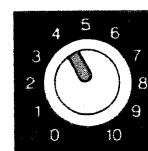

USING HEADPHONES

- 19** Plug in the headphone cord into the headphone jack and adjust the headphone volume.

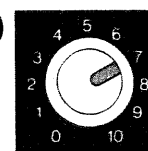

HELPFUL HINTS FOR USING THE PA-80

- Do not turn on or off the power or unplug the power cord while the volume is at a high level.
- Pulling out the plug while the volume of the amplifier is raised up will put a great strain on the speaker and may even damage it. Always unplug cords with the volume decreased to "0".
- Keep away from interferences that induce high levels of noise such as fluorescent lamps and neon lights.
- Avoid places that are dusty or of high humidity.
- For changing fuses, use the ones provided by our company.
- Avoid places where the PA-80 would be exposed to direct sunlight, positioned close to objects that may radiate heat or places that are not ventilated.

IN CASE OF TROUBLE

If there are problems, read the following steps to see if anything can be done. If you still cannot fix it, then call your nearby Roland dealer.

CONDITION	CAUSE	MEASURE
even if the power is switched on, the pilot lamp does not light up and no sound comes out	the power plug may not be plugged in completely. the fuse may have gone out	plug in the cord completely. replace the fuse with a new one.
the pilot lamp goes on but no sound comes out	incomplete connection between the speaker and cord. channel volume and master volume knobs are at "0". stand by switch is off.	connect properly. raise the volume to appropriate level. reset the STAND BY switch to ECHO or REV.
sound comes out from only one side	only one speaker is functioning; incomplete connection. the Balance knob is turned all the way up to either side. Either the "L" or "R" master volume is at "0".	check the cord and connect properly. set the balance knob in the appropriate place. adjust the knob at "0" to an appropriate level.
distortions in the sound	malfunction of speakers incomplete connections of connection jacks	replace speakers connect completely.
cannot obtain the echo effect	the STAND BY switch is at REV. the effect volume and echo volume knobs are at "0". not completely connected with the echo machine.	switch the STAND BY switch to ECHO. adjust the effect volume and the echo volume to an appropriate level. connect completely.
cannot obtain the reverberation effect	STAND BY switch is at ECHO. the effect volume and reverberation volume are at "0".	switch the STAND BY switch to REV. adjust the effect volume and the reverberation volume to an appropriate level.
clipping sounds	attenuator channel volume and the master volume settings are not appropriate.	referring to the Owner's Manual, under Attenuator Channel Volume and Master Volume, make adjustments properly.

CAUTIONS

- To prevent damage to the speakers, 4Ω speakers must be rated at 40 watts or more, and 8Ω speakers at 30 watts or more.
- The total impedance for each output channel must not be lower than 4Ω. This means that if 8Ω speakers are used, two speakers may be connected to each output channel to increase the power output to 40 watts per channel.
- Make sure the line voltage in your area meets the requirements given in the specifications.
- Check with your local Roland dealer if you want to use this unit in a foreign country.
- Plug the amplifier in before turning ON the POWER switch ⑩.

SPECIFICATIONS

Power Output	
4Ω Speakers:	80 W rms (40 W + 40 W)
8Ω Speakers:	60 W rms (30 W + 30 W)
Input Channels:	6
Inputs	
Channel inputs:	-50 to -10 dBm
PHONO:	-50 dBm/1 kHz
AUX IN:	-20 dBm
MIXING BUSS IN:	-15 dBm
ECHO RETURN:	-20 dBm
Outputs	
MASTER OUTPUT:	+4 dBm
RECORDING OUT:	0 dBm
ECHO SEND:	0 dBm
SPEAKER OUT:	min 4Ω
AC OUTLET:	max 300 W (unswitched)
Power Consumption:	76 W
Dimensions:	473(W) × 175(H) × 415(D) mm
Weight:	12 kg

* Specifications are subject to change without notice.

BLOCK DIAGRAM

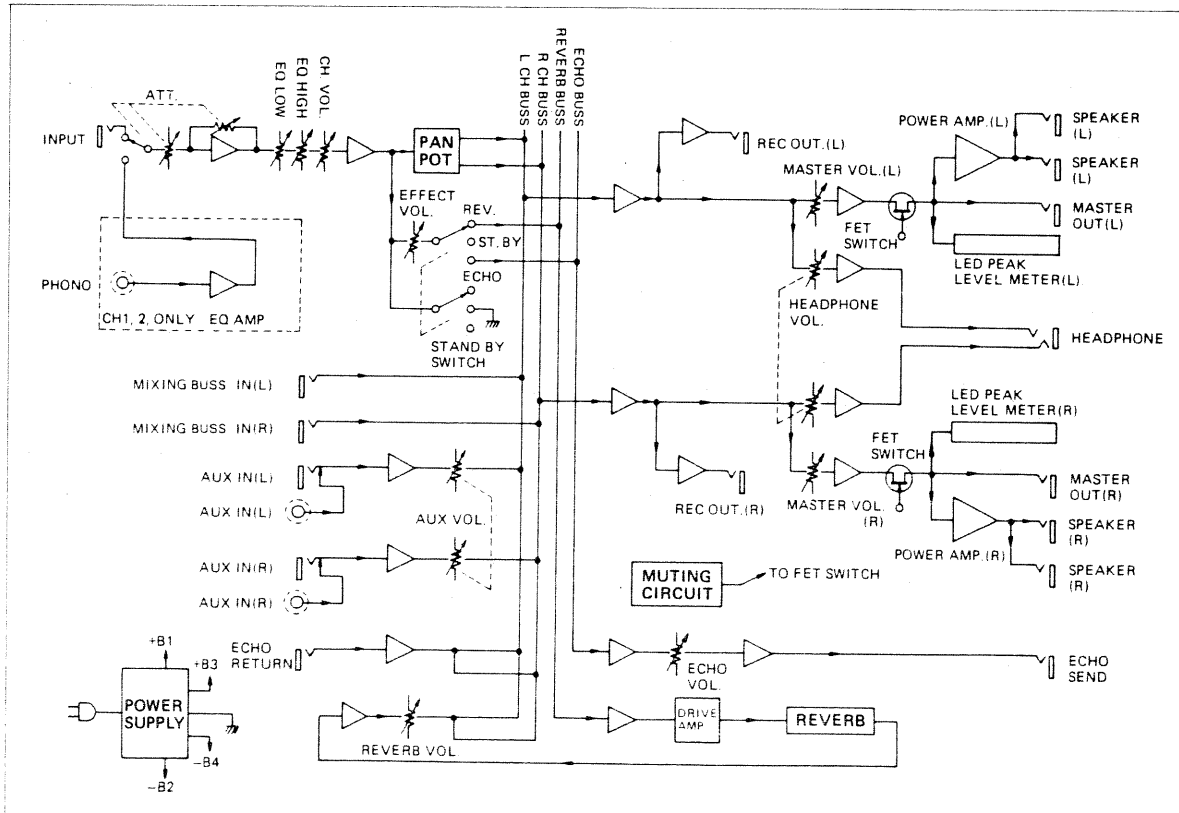

 Roland®

17047334

PA-80 OWNER'S MANUAL '80 AUG. F-2

UPC

17047334



18991

Roland Corporation