

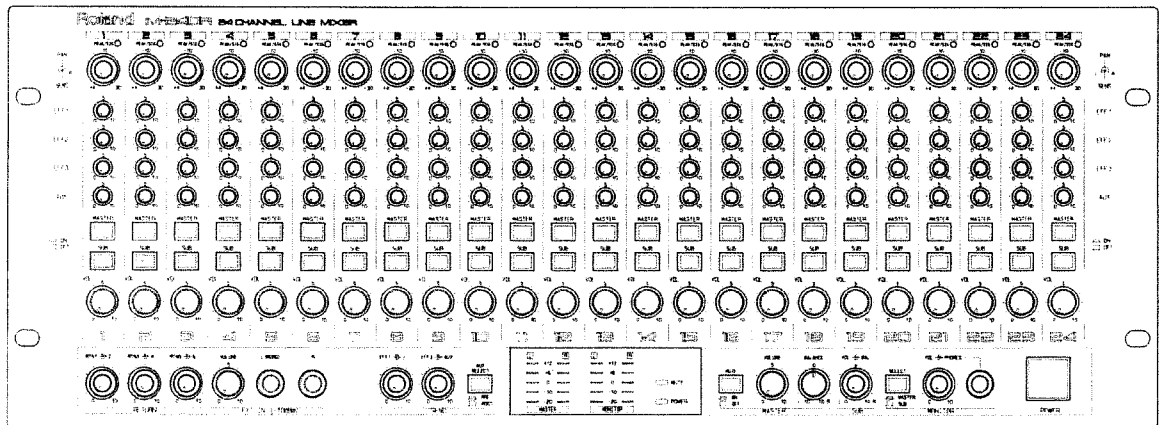

# Roland

## 24 CHANNEL LINE MIXER

# M-240R

## OWNER'S MANUAL



	<b>CAUTION</b> RISK OF ELECTRIC SHOCK DO NOT OPEN	
<b>ATTENTION</b> RISQUE DE CHOC ELECTRIQUE NE PAS OUVRIR		
<p><b>CAUTION:</b> TO REDUCE THE RISK OF ELECTRIC SHOCK, DO NOT REMOVE COVER (OR BACK). NO USER-SERVICEABLE PARTS INSIDE. REFER SERVICING TO QUALIFIED SERVICE PERSONNEL.</p>		



The lightning flash with arrowhead symbol, within an equilateral triangle, is intended to alert the user to the presence of un-insulated "dangerous voltage" within the product's enclosure that may be of sufficient magnitude to constitute a risk of electric shock to persons.



The exclamation point within an equilateral triangle is intended to alert the user to the presence of important operating and maintenance (servicing) instructions in the literature accompanying the product.

INSTRUCTIONS PERTAINING TO A RISK OF FIRE, ELECTRIC SHOCK, OR INJURY TO PERSONS.

## IMPORTANT SAFETY INSTRUCTIONS

**WARNING** — When using electric products, basic precautions should always be followed, including the following:

1. Read all the instructions before using the product.
2. Do not use this product near water — for example, near a bathtub, washbowl, kitchen sink, in a wet basement, or near a swimming pool, or the like.
3. This product should be used only with a cart or stand that is recommended by the manufacturer.
4. This product, either alone or in combination with an amplifier and headphones or speakers, may be capable of producing sound levels that could cause permanent hearing loss. Do not operate for a long period of time at a high volume level or at a level that is uncomfortable. If you experience any hearing loss or ringing in the ears, you should consult an audiologist.
5. The product should be located so that its location or position does not interfere with its proper ventilation.
6. The product should be located away from heat sources such as radiators, heat registers, or other products that produce heat.
7. The product should avoid using in where it may be effected by dust.
8. The product should be connected to a power supply only of the type described in the operating instructions or as marked on the product.
9. The power-supply cord of the product should be unplugged from the outlet when left unused for a long period of time.
10. Do not tread on the power-supply cord.
11. Do not pull the cord but hold the plug when unplugging.
12. When setting up with any other instruments, the procedure should be followed in accordance with instruction manual.
13. Care should be taken so that objects do not fall and liquids are not spilled into the enclosure through openings.
14. The product should be serviced by qualified service personnel when:
  - A. The power-supply cord or the plug has been damaged; or
  - B. Objects have fallen, or liquid has been spilled into the product; or
  - C. The product has been exposed to rain; or
  - D. The product does not appear to operate normally or exhibits a marked change in performance; or
  - E. The product has been dropped, or the enclosure damaged.
15. Do not attempt to service the product beyond that described in the user-maintenance instructions. All other servicing should be referred to qualified service personnel.

## SAVE THESE INSTRUCTIONS

**WARNING:** THIS APPARATUS MUST BE EARTHED

For the U.K.

**IMPORTANT:** THE WIRES IN THIS MAINS LEAD ARE COLOURED IN ACCORDANCE WITH THE FOLLOWING CODE.  
GREEN-AND-YELLOW: EARTH, BLUE: NEUTRAL, BROWN: LIVE

As the colours of the wires in the mains lead of this apparatus may not correspond with the coloured markings identifying the terminals in your plug proceed as follows:

The wire which is coloured GREEN-AND-YELLOW must be connected to the terminal in the plug which is marked by the letter E or by the safety earth symbol  or coloured GREEN or GREEN-AND-YELLOW.

The wire which is coloured BLUE must be connected to the terminal which is marked with the letter N or coloured BLACK.

The wire which is coloured BROWN must be connected to the terminal which is marked with the letter L or coloured RED.

The product which is equipped with a THREE WIRE GROUNDING TYPE AC PLUG must be grounded.

Thank you for purchasing the Roland M-240R. The M-240R is a compact yet versatile, high-quality 24 channel line mixer.

To make the best use of the unit, please read this manual carefully.

## ■ FEATURES

- The M-240R is a 4U rack-mountable, 24 channel mixer specifically designed for line input sources.
- There is independent control over each signal's input level (-30dBm to +4dBm) and stereo positioning (panning).
- The M-240R features 4 independent SEND OUT jacks and 6 Stereo RETURN jacks. What's more, the output of 1 of the 4 SEND OUT jacks can be switched to pre-fader or post-fader. These jacks can be used for monitoring applications or with various effect devices.
- In order to maintain the signal integrity and low noise output common to all M-series mixers, the M-240R has been designed to meet exacting standards.
- Two independent outputs (MASTER OUT and SUB OUT) are provided. Each channel's output can be sent to either or both of these outputs using the Output Select Switch. Moreover, the MASTER OUT includes a Mute Switch and Mute Indicator which enhance the M-240R's flexibility.
- As well as the MASTER and SUB controls, a MONITOR control is also provided. This allows independent volume control of the MASTER OUT signal or the SUB OUT signal through the MONITOR OUT jacks. These signals can also be heard through headphones.
- The MONITOR BUS INPUT allows you to hear the tempo "click" from a sequencer through the MONITOR OUT jacks or the Headphone jack.
- The BUS INPUT contains the Send jacks (AUX, EFF1-3) which permit "full-function" stacking of M Series mixers.
- The M-240R's MASTER OUT XLR connectors (balanced output) allow the unit to function in professional environments.
- A Peak/Signal (PEAK/SIG) Indicator is provided for each channel and a 5-segment Peak Meter is provided in the MASTER/SUB section. These indicators assist in setting accurate signal levels. In addition, you can monitor the pre-fader signal level of the MASTER OUT (with the MONITOR Peak Meter) by pressing the MONITOR SELECT switch.

# TABLE OF CONTENTS

■ Features .....	3	4 Level Diagram .....	21
■ Important Notes .....	5	5 Input/Output Standard .....	22
1 Block Diagram and Signal Flow ....	7	6 Specifications .....	23
1. Channel Section .....	7	Information .....	24
2. Master Section .....	7		
<Inputs>			
a. RETURN .....	7		
b. External In (EXT IN) .....	7		
c. BUS IN .....	7		
<Outputs>			
d. MASTER OUT .....	8		
e. SUB OUT .....	8		
f. MONITOR OUT .....	8		
g. Effect Send (EFFECT 1-3 SEND) .....	8		
h. AUX Send (AUX SEND) .....	8		
2 Panel Descriptions .....	9		
1. Channel Section .....	9		
2. Master Section .....	10		
3. Rear Panel .....	12		
3 Connections and Operation .....	14		
■ Basic Procedure .....	14		
1. Basic Setup with Electronic Musical Instruments, etc. ....	14		
■ Mixing Electronic Musical Instruments etc. ....	14		
2. Setup Example with Effects Device .....	15		
■ Effects processing with a delay, reverb, etc. ....	15		
3. Example Setup using the MASTER/SUB Outs .....	16		
■ Simple grouping using the SUB Outs ....	16		
4. Monitoring ( Foldback ) with AUX outputs and MONITOR OUT .....	18		
■ Foldback .....	18		
■ Monitoring using the MONITOR OUT ....	19		
[1] Monitoring the signal before the MASTER OUT volume control .....	19		
[2] Monitoring the signal before the SUB OUT volume control ....	19		
5. Stacking Examples .....	20		

Copyright©1990 by ROLAND CORPORATION  
 All rights reserved. No part of this publication may be reproduced in any form without the written permission of ROLAND CORPORATION.

# ■ Important Notes

In addition to the items listed under Safety Precautions on page 2, please read and adhere to the following:

## **[Power Supply]**

- When making any connections with other devices, always turn off the power to all equipment first; this will help prevent damage or malfunction.
- Do not use this unit on the same power circuit with any device that will generate line noise, such as a motor or variable lighting system.
- Avoid damaging the power cord; do not step on it, place heavy objects on it etc.

## **[Placement]**

- Do not subject the unit to temperature extremes (eg. direct sunlight in an enclosed vehicle). Avoid using or storing the unit in dusty or humid areas or areas that are subject to high vibration levels.
- Using the unit near power amplifiers (or other equipment containing large transformers) may induce hum.
- This unit may interfere with radio and television reception. Do not use this unit in the vicinity of such receivers.
- Do not expose this unit to temperature extremes (eg. direct sunlight in an enclosed vehicle can deform or discolor the unit) or install it near devices that radiate heat.

## **[Maintenance]**

- For everyday cleaning wipe the unit with a soft, dry cloth (or one that has been slightly dampened with water). To remove stubborn dirt, use a mild neutral detergent. Afterwards, be sure to wipe the unit thoroughly with a soft, dry cloth.
- Never use benzene, thinners, alcohol or solvents of any kind, to avoid the risk of discoloration and/or deformation.

- [Additional Precautions]**
- Protect the unit from strong impact.
  - Do not allow objects or liquids of any kind to penetrate the unit. In the event of such an occurrence, discontinue use immediately. Contact qualified service personnel as soon as possible.
  - Never strike or apply strong pressure to the signal level indicators.
  - A small amount of heat will radiate from the unit, and thus should be considered normal.
  - Before using the unit in a foreign country, consult with qualified service personnel.
  - Should a malfunction occur (or if you suspect there is a problem) discontinue use immediately. Contact qualified service personnel as soon as possible.

# 1 Block Diagram and Signal Flow

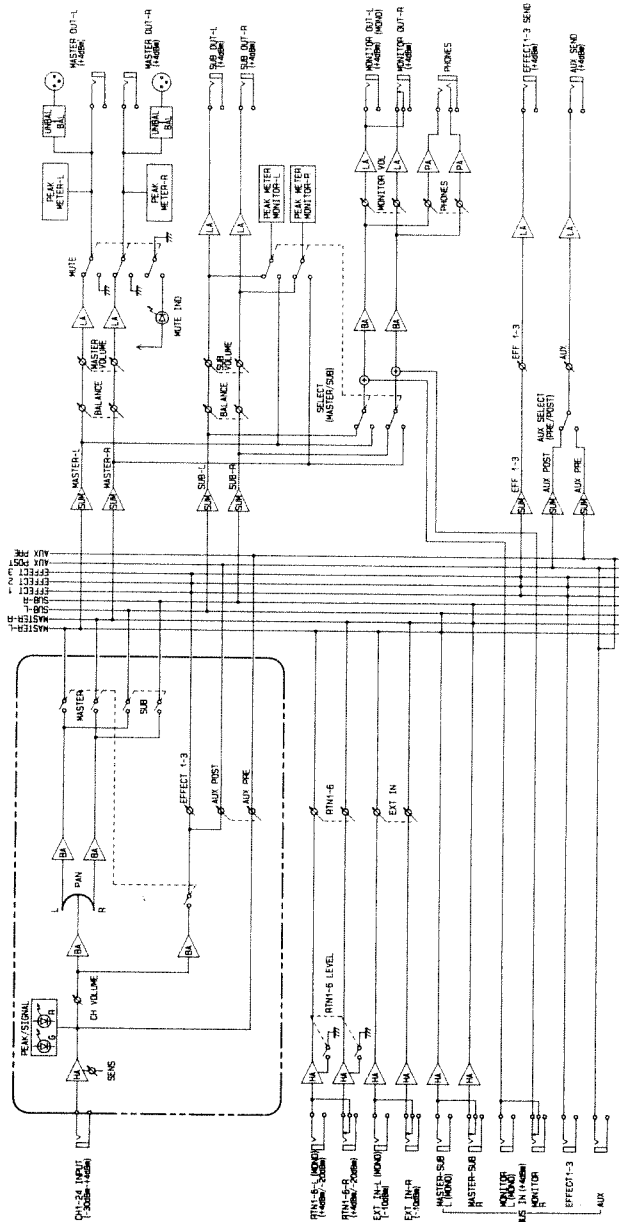

## 1. Channel Section

The signal fed into each input jack will first be sent to the Head Amplifier. The input sensitivity is controlled with the SENS Control Knob. While a signal is present, the PEAK/SIG indicator will light (green). When the input level is excessive, the indicator will change to red. The signal from the Head Amplifier is sent to the Channel Volume control, and then sent to the Buffer Amplifier. The signal is split into L and R feeds at the Panpot, then split into two feeds after being sent to another Buffer Amplifier. The split signal will then be sent to the Output Select Switches (MASTER/SUB), then to the Master section. The signal can then be taken before or after the channel fader. Then it will be sent to the Master Section after being sent to the Effect Volume control or AUX Volume control.

## 2. Master Section

- <INPUT>
- a. **Return (RTN 1-6)**  
Signals sent to RETURN jacks will be sent to a Head Amplifier and to the Return Volume control, then finally to the Master section.
  - b. **EXT IN (External In)**  
Signals input through the EXT IN (External In [front panel]) jacks will be sent to a Head amplifier and adjusted at the External In Volume control, then finally sent to the Master section.
  - c. **Bus In (MASTER L/R, SUB L/R, MONITOR L/R, EFFECT 1-3, AUX)**  
Signals input through each BUS IN jack will be directly mixed with the MASTER OUT, SUB OUT, Effect Send and AUX Send circuits, then sent to the MASTER OUT, SUB OUT, Effect Send and AUX Send.

## <OUTPUT>

- d. **MASTER OUT**  
Left and Right signals input to a channel (where the Output Select Switch MASTER is set to "on"), and signals input via the RETURN, EXT IN or BUS IN (MASTER) jacks will be mixed. The mixed signal's level is adjusted by the Master Balance control (L and R volume balance), then adjusted again at the Master Volume control before being output from the MASTER OUT jacks.
- e. **SUB OUT**  
Left and Right signals input to a channel (where the Output Select Switch SUB is set to "on"), and signals input to the BUS IN (SUB) jacks will be mixed. The mixed signal's level is adjusted by the Sub Balance control (L and R volume balance), then adjusted again at the Sub Volume control before being output from the SUB OUT jacks.

## f. MONITOR OUT

Signals (pre-fader) before the MASTER Volume control or SUB Volume control) selected at the Monitor Select Switches (MASTER/SUB) and signals from the BUS IN (MONITOR) will be mixed and level-adjusted at the Monitor Out Volume control. The resulting signals are then sent to the MONITOR OUT jacks (the same signal will also be sent to the Headphone jack).

## g. Effect Send (EFFECT 1-3 SEND)

Signals from the Effect Volume control of each channel and from the BUS IN jacks (EFF 1-3) are mixed and level-adjusted at the Effect Send Volume control, then sent to the Eff (Effect) Send jacks.

## h. AUX Send (AUX SEND)

Signals from the AUX Volume control of each channel and from the BUS IN jacks (AUX) are mixed and level-adjusted at the AUX Send Volume control, then sent to the AUX Send jack.





## 2 PANEL DESCRIPTIONS

### 1. Channel Section

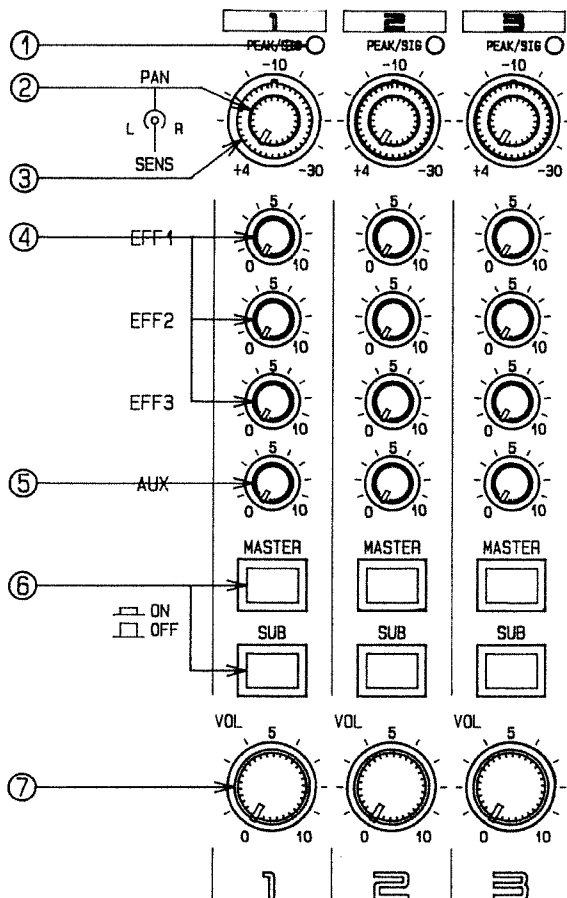

#### ① Peak Signal Indicator

These indicators will be green when signals are fed into the CHANNEL INPUT jacks. The indicators become red if the signal level is excessive. In other words, indicators are green when the signal level is  $-20\text{dB}$  of nominal level after passing the input sensitivity circuits, and red at  $-6\text{dB}$  of the clipping level.

#### ② SENS Knob

Use this knob to adjust the input sensitivity according to the level of the incoming signal. The appropriate position of this knob is the point at which the PEAK/SIG Indicator is green, and red only on the highest input peaks. If the PEAK/SIG Indicator does not light at all with a signal present, set the SENS Knob higher or increase the input level.

\* The input range is  $-30\text{ dBm}$  to  $+4\text{ dBm}$ .

#### ③ Panpot Knob

This knob positions the sound within the stereo sound field. At the center position, the sound will be heard from the center of the sound field.

#### ④ Effect Volume Knobs (1-3)

These knobs control the level of the signals being sent to the Effect Send jacks.

\* The signal to be sent to the Effect Send jacks is extracted after the Channel Volume Knob (Post-fader).

\* The Effect Volume Knob will not function unless the Output Select Switch MASTER is turned on in the channel where the effect is to be used.

#### ⑤ AUX Volume Knobs

These knobs adjust the level of the signals to be sent to the AUX Send.

\* You can select the point at which the signals sent to AUX Send are extracted using the AUX Select Switch.

\* When "POST" is selected with the AUX Select Switch, the AUX Volume Knob does not function unless the Output Select Switch "MASTER" is turned on in the channel where the effect is to be used.

#### ⑥ Output Select Switch (MASTER/SUB)

These switches select the output jacks (MASTER OUT or SUB OUT) for the signal from each channel.

#### ⑦ Channel Volume Knob

These knobs control the overall level of each channel's signal before being sent to the Master section.

\* The nominal output of the Channel Volume Knob is obtained when it is set to "10".

## 2. Master Section

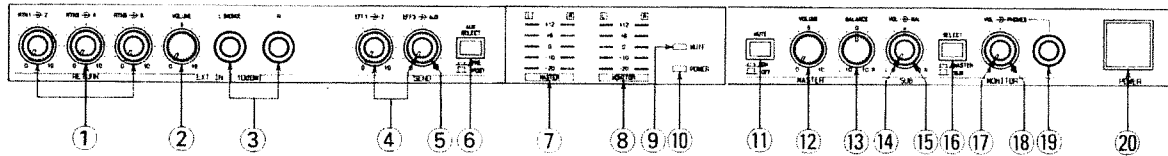

### ① Return Volume

These knobs adjust the level of the signal fed into the RETURN jacks.

\* The nominal output of Return Volume is obtained when it is set to "10".

### ② EXT IN (External In) Volume

This knob adjusts the level of the signal fed into the EXT IN jacks.

\* The nominal output of the External Volume is obtained when it is set to "10".

### ③ EXT IN (External In) Jacks

This is where external devices (eg. another mixer) are connected to the M-240R. It consists of a stereo pair, but can be used in mono by using the Left [ L(Mono) ] side only.

### ④ Effect Send Volume

These knobs control the final output level of the effect signal of each channel. The signal is extracted after the Channel Volume Knob (Post-fader).

\* The nominal output of the Effect Send Volume is obtained when it is set to "8".

### ⑤ AUX Send Volume

This knob controls the final output level of the AUX signal of each channel.

\* The nominal output level is obtained when the AUX Send Volume is set to "8".

### ⑥ AUX Select Switch

This switch selects the point at which the signal to be sent to the AUX Send is extracted from the signal path. In the PRE (pre-fader) position, the signal is extracted before the Channel Volume Knob. In the POST (post-fader) position, the signal is taken after the Channel Volume Knob.

### ⑦ Master Peak Meter

This is a peak-reading meter that indicates the output level from the MASTER OUT jacks. At 0dB, the standard level (+4dBm) is output from the MASTER OUT jacks.

### ⑧ Monitor Peak Meter

This is a peak-reading meter that indicates the post-fader signal from the SUB OUT jacks or pre-fader signal from the MASTER OUT jacks. At 0dB, the standard level (+4dBm) is output from the SUB OUT jacks.

\* When "MASTER" is selected at the Monitor Select Switch, the pre-fader signal from the MASTER OUT jacks is indicated.

### ⑨ Mute Indicator

This indicator lights (orange) when the signal output from the MASTER OUT jacks is muted.

### ⑩ Power Indicator

This indicator lights (red) when the mixer is switched on.

### ⑪ Mute On/Off Switch

This switch turns the output of the MASTER OUT jacks on and off.

### ⑫ Master Volume Knob

This knob adjusts the overall output level at the MASTER OUT jacks.

\* The nominal output level is obtained when the Master Volume Knob is set to "8".

### ⑬ Master Balance Knob

This knob controls the volume balance (L and R) of the signal sent to the MASTER OUT jacks. At the center position, the volumes of the L and R signals are equal.

**⑭ Sub Out Volume Knob**

This knob controls the overall output level at the SUB OUT jacks.

**\* The nominal output is obtained when the Sub Out Volume Knob is set to "8".**

**⑮ Sub Out Balance Knob**

This knob controls the volume balance (L and R) of the signal sent to the SUB OUT jacks. At the center position, the volumes of the L and R signals are equal.

**⑯ Monitor Select Switch**

This switch selects the signal to be output from the MONITOR OUT jacks. When pressed, the pre-fader signal of the MASTER OUT jacks is selected. When pressed again, the pre-fader signal of the SUB OUT jacks is selected.

**\* The signal to the Headphone jack can be selected in the same way.**

**⑰ Monitor Out Volume**

This knob controls the output level of the signal sent to the MONITOR OUT jacks.

**\* The nominal output is obtained when the Monitor Out Volume is set to "8".**

**⑱ Headphone Volume Knob**

This knob controls the output level of the signal sent to the Headphone jack.

**⑲ Headphone Jack**

Connect stereo headphones to this jack. The signal sent to the headphone jack is the same as that sent to the MONITOR OUT jack.

**⑳ Power Switch**

Press this switch to turn the unit on and off.

**\* Before switching the mixer on or off, set the Master Volume Knob to "0".**

**\* After the mixer is switched on, the muting circuits work for approx. 2 seconds and therefore no sound will be heard.**

### 3. Rear Panel

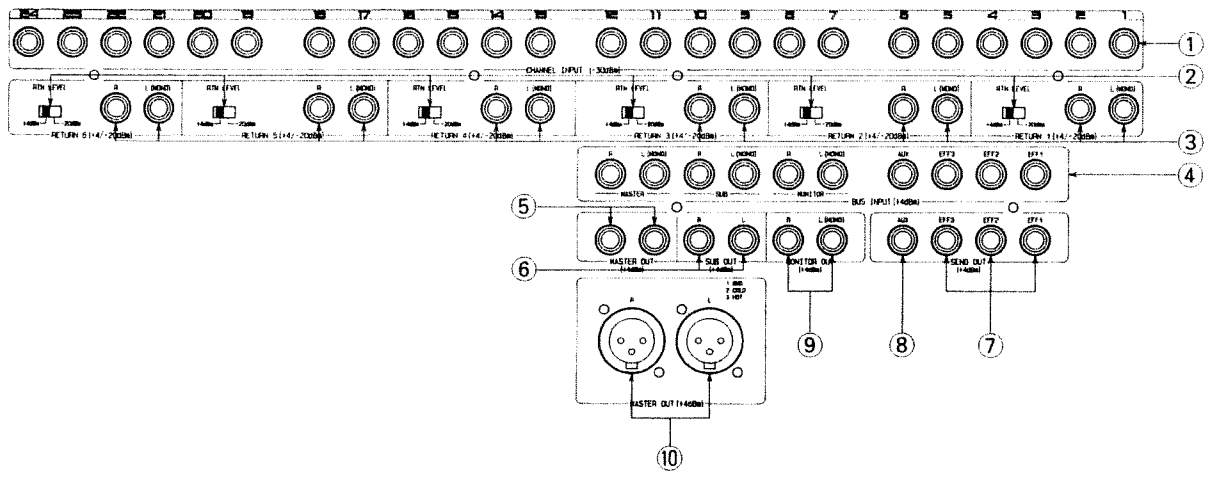

**① CHANNEL INPUT Jacks**

Connect electronic musical instruments (or CD player, for example) to these jacks. Be sure to use standard 1/4" phone plug.

\* This mixer uses an unbalanced input system.

**② RTN LEVEL (Return Level) Switches**

These switches controls the input level (+4 dBm or -20 dBm) of the return signal depending on the unit or device used.

**③ RETURN Jacks**

These jacks receive the return signal from an effect device. They can also be used as auxiliary inputs. The RETURN jacks consist of stereo pairs but can be used in mono by using the L(MONO) side only.

**④ BUS IN Jacks**

Signals fed into these jacks can be directly mixed with the output signals from the MASTER OUT jacks, SUB OUT jacks, MONITOR OUT jacks, AUX (SEND OUT) and EFF (SEND OUT) jacks. For instance, when two M-240Rs are stacked by connecting the MASTER OUT jacks, SUB OUT jacks, MONITOR OUT jacks, AUX and EFF (SEND OUT) jacks of the second mixer to the corresponding BUS IN Jacks on the first mixer, the total number of the input channels can be increased to up to 48.

**⑤ MASTER OUT Jacks**

These jacks are for connection to a power amplifier which ultimately drive the house speaker systems (or stage monitors, etc.). The jacks output the combined (mixed) signal from channel inputs (where the Output Select Switch MASTER is turned on), the RETURN, EXT IN and BUS IN jacks (MASTER).

⑥ **SUB OUT Jacks**

These jacks are also for connection of a power amplifier (to drive house or monitor systems). The jacks output the combined (mixed) signal from channel inputs (where the Output Select Switch SUB is turned on) and the BUS IN jacks (SUB).

⑦ **EFF (Effect SEND OUT) Jacks**

Signals to be processed are sent to the desired effects device from these jacks.

⑧ **AUX (SEND OUT) Jack**

Signal to be sent to an effect device or monitor are output from this jack.

⑨ **MONITOR OUT Jacks**

These jacks output pre-fader signals from MASTER OUT or the post-fader signals from SUB OUT.

This output consists of a stereo pair, but can be used in mono by using the L(MONO) side only.

⑩ **MASTER OUT Connector**

This is an XLR (balanced type) connector for connection to a power amplifier, etc.

\* The MASTER OUT jacks (standard 1/4" phone jack) and MASTER OUT connector (XLR type) can be used simultaneously.

\* There are two types of pin assignments for XLR connectors; American and European. This mixer adopts the American system; 1st: ground, 2nd: cold, 3rd: hot. Before connecting the mixer to another unit, confirm compatibility of pin assignments.

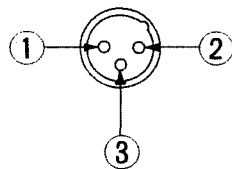

1:GND  
2:COLD  
3:HOT

# 3 CONNECTIONS AND OPERATION

## ■ Basic Procedure

- ① Make sure that the mixer is switched off, then connect the power cord to an AC outlet.
- ② Connect all of the desired instruments and equipment to the M-240R (Refer to connections diagrams).
- ③ For each input channel used, set the PAN knob to the "center" position, the SENS knob to "+4" and all the other knobs to the "0" positions.
- ④ Ensure that all the connections are correctly and securely made. Switch on all the connected equipment first, then the M-240R, and finally the power amplifier. (Power down in the reverse order.)

## 1. Basic Setup With Electronic Musical Instruments, etc.

### ■ Mixing Electronic Musical Instruments etc.

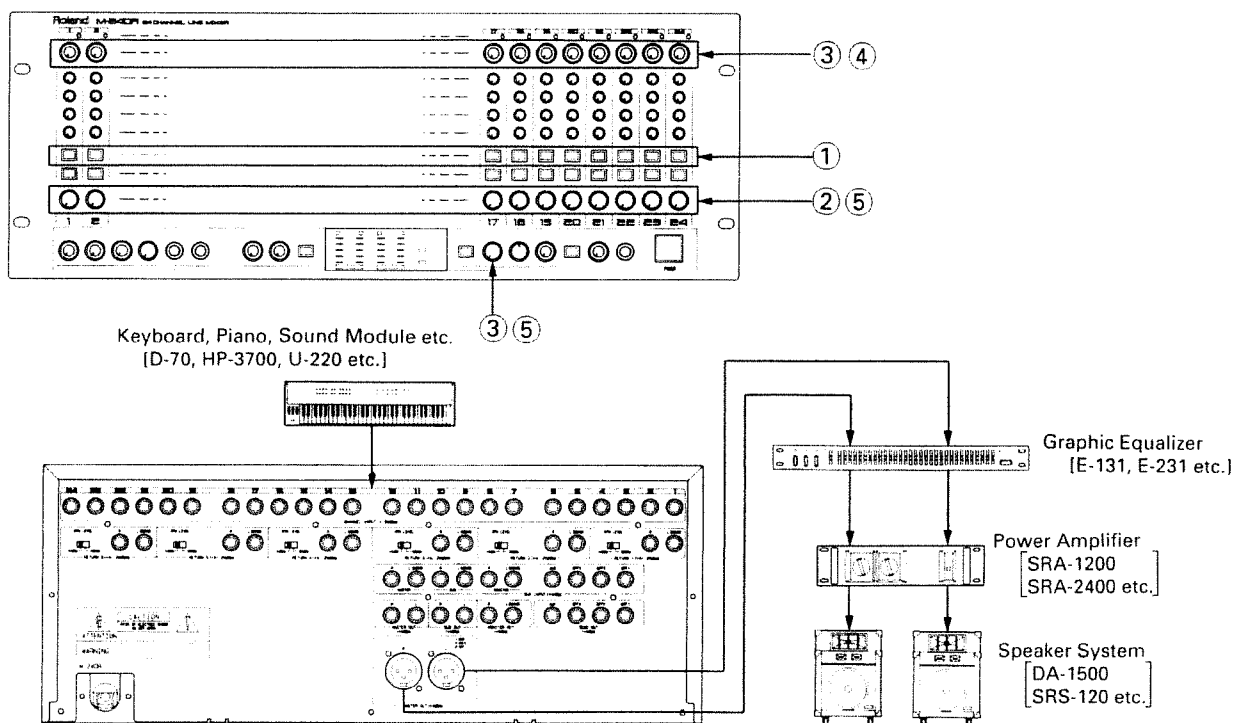

- ① Press "MASTER" of the Output Select Switches of each channel.
- ② Set the Channel Volume Knob to approx. "7".
- ③ Raise the Master Volume Knob to an appropriate level. Adjust the volume of each of the connected instruments by using the SENS Knob of the corresponding channel.
- ④ Position the sound of each instrument within the stereo sound field by using the PAN knob of each channel.
- ⑤ Adjust the relative volume of each instrument by using the Channel Volume (VOL) knob of each channel. If necessary, readjust the overall volume with the Master Volume knob.

\* If the PEAK/SIG Indicator turns red too frequently, adjust the SENS Knob. (The indicator should turn red only on input peaks).

## 2. Setup Example With Effects Device

### ■ Effect Processing with a Delay, Reverb, etc.

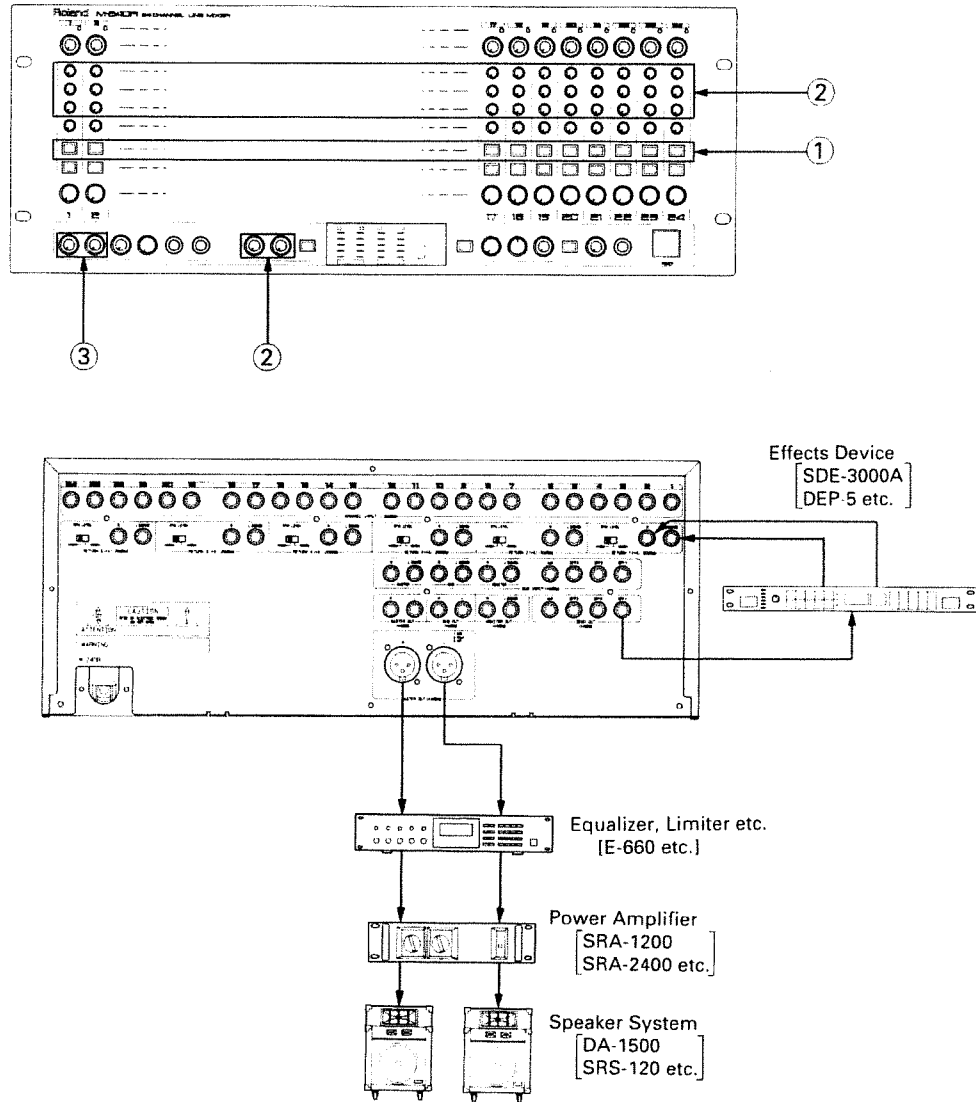

- ① Press "MASTER" (of the Output Select Switches) on the channel(s) you wish to process.
- ② Raise the Effect Volume Knob of the desired channel(s) to an appropriate level, then adjust the overall output level with the Effect Send Volume Knob in the Master Section.
- ③ Adjust the level of the signal returned from the effect device using the Return Volume Knob.

- \* The direct sound is processed within the mixer, so return only the processed signal to the mixer.
- \* The signal for the Effect Send will be taken after passing the Channel Volume Knob.
- \* If you insert an equalizer between the mixer and a power amplifier, you can control the overall tone quality of the mixer's output.

### 3. EXAMPLE SETUP USING THE MASTER/SUB OUTPUTS

The M-240R features two independent outputs; MASTER OUT and SUB OUT jacks (each as a stereo pair).

#### ■ Simple Grouping using the SUB OUT Jacks

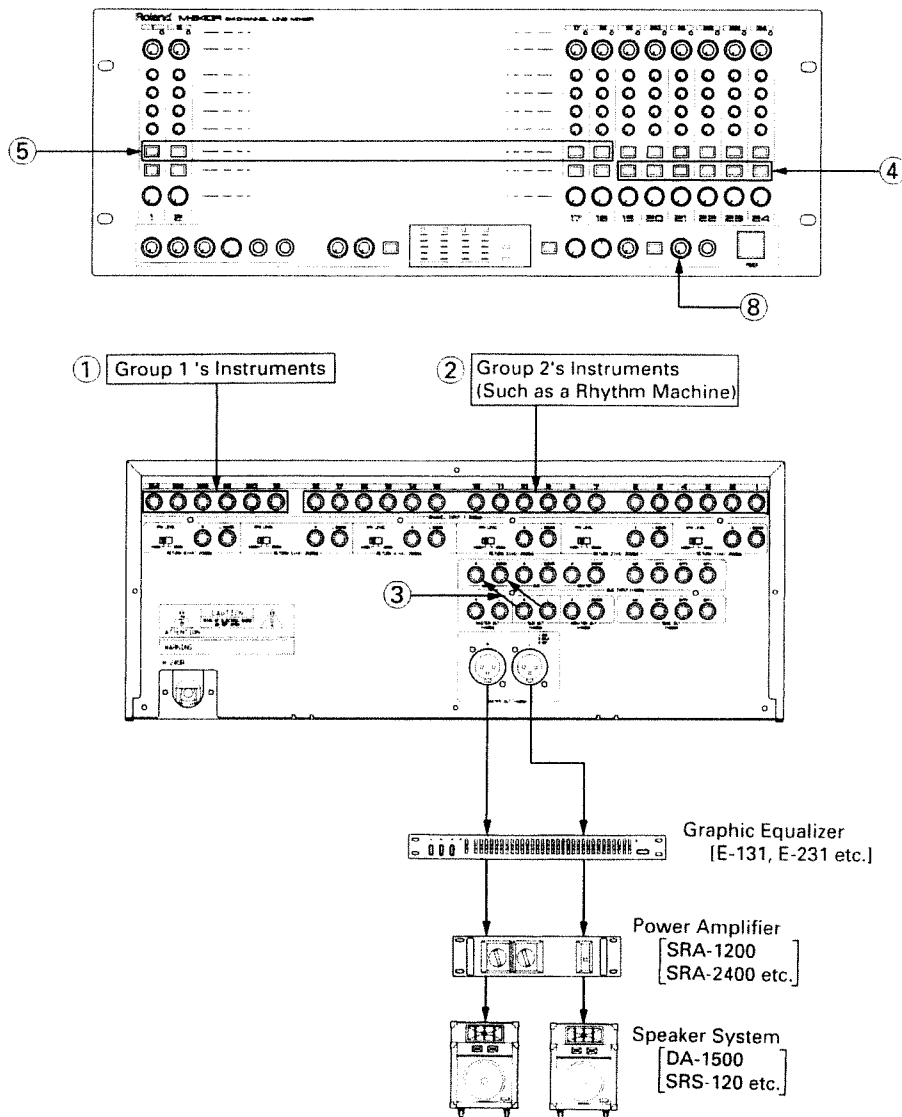



- ① Connect each instrument of a pre-determined group (Group 1) to input jacks of each required channel.
- ② Connect each instrument of a second group (Group 2—such as a rhythm machines) to input Jacks of unused channels.
- ③ Connect the SUB OUT jacks (L and R) to the MASTER BUS INPUT jacks (L and R).
- ④ Press Output Select Switch SUB of each channel of Group 1. (Set Output Select Switch MASTER to OFF.)
- ⑤ Press Output Select Switch MASTER of the channels of Group 2. (Set Output Select Switch SUB to OFF.)
- ⑥ Adjust the volume and pan position of Group 2 instruments. (See page 14 “Basic Setup with Electronic Musical Instruments, etc.”.)

**\* The sound of the instruments of Group 2 can be monitored through the amplifier or speakers connected to the MASTER OUT jacks. Also, by selecting “MASTER” with the Monitor Select Switch, the sound can be monitored through headphones. (The signal is extracted before the Master Volume Knob.)**

- ⑦ Adjust the volume and pan position of the Group 1 instruments. (See page 14 “Basic Setup with Electronic Musical Instruments, etc.”.)

**\* The sound of the Group 1 instruments can be monitored through the amplifier or speakers connected to the MASTER OUT jacks. Also, by selecting “SUB” with the Monitor Select Switch, the sound can be monitored through headphones. (The signal is extracted before the Sub Volume control.)**

- ⑧ The overall volume of the Group 1 instruments can be controlled with the Sub Out Volume Knob.

**\* If you wish to add effects to the Group 1 instruments, connect an effects device between the SUB OUT jacks and the MASTER BUS IN jacks.**

## 4. Monitoring (Foldback) with AUX and the MONITOR OUT

### ■ Foldback

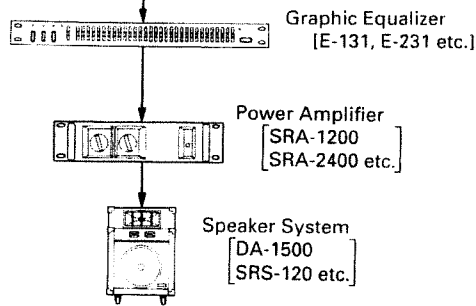
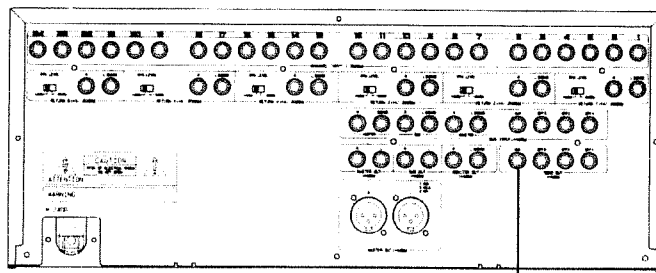
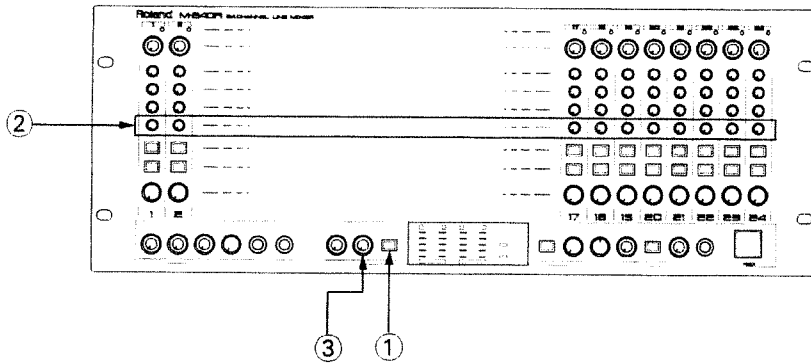

- ① Press the AUX Select Switch in the Master section (set it to "PRE").
- ② Rotate the AUX Volume Knob of each channel to adjust the volume of the monitor signal.
- ③ Adjust the overall volume with the AUX Send Volume Knob in the Master section.

\* Regardless of the position of the Channel Volume and Master Volume Knobs, you can adjust the balance of the monitor signal.

\* By inserting an equalizer or a limiter (etc.) between the mixer and power amplifier, you can obtain additional control over the mixer's output.

■ Monitoring using the MONITOR OUT Jacks

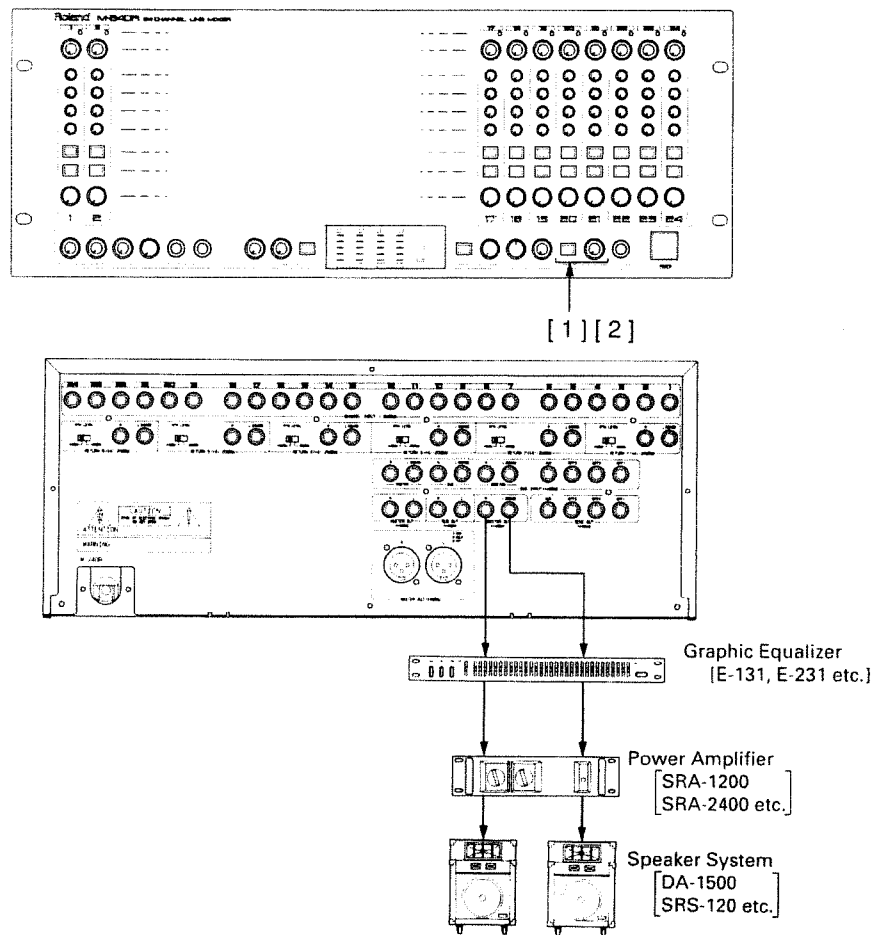

**[1] Monitoring the signal before the Master Out Volume Knob**

- ① Set the Monitor Select Switch in the Master section to "MASTER".
- ② Adjust the volume with the Monitor Volume or Headphone Volume. (The MONITOR Peak Meter indicates the pre "Master Out Volume" level.)

\* You can adjust the monitor volume regardless of the position of the Master Volume Knob.

\* By inserting an equalizer or a limiter (etc.) between the mixer and power amplifier, you can obtain additional control over the mixer's output.

**[2] Monitoring the signal before the Sub Out Volume Knob**

- ① Press the Monitor Select Switch in the Master section to select "SUB".
- ② Adjust the volume with the Monitor Volume or Headphone Volume. (The MONITOR Peak Meter indicates the post "Sub Out Volume" level.)

## 5. Stacking Examples

Connecting two or more mixers to increase the total number of channels is called "stacking". You can "stack" the M-240R with another M-series mixer for even greater mixing capabilities.

For example, by connecting the M-240R to an M-12E, you can mix the signals from microphones and guitars with those from electronic musical instruments. (See following diagram.)

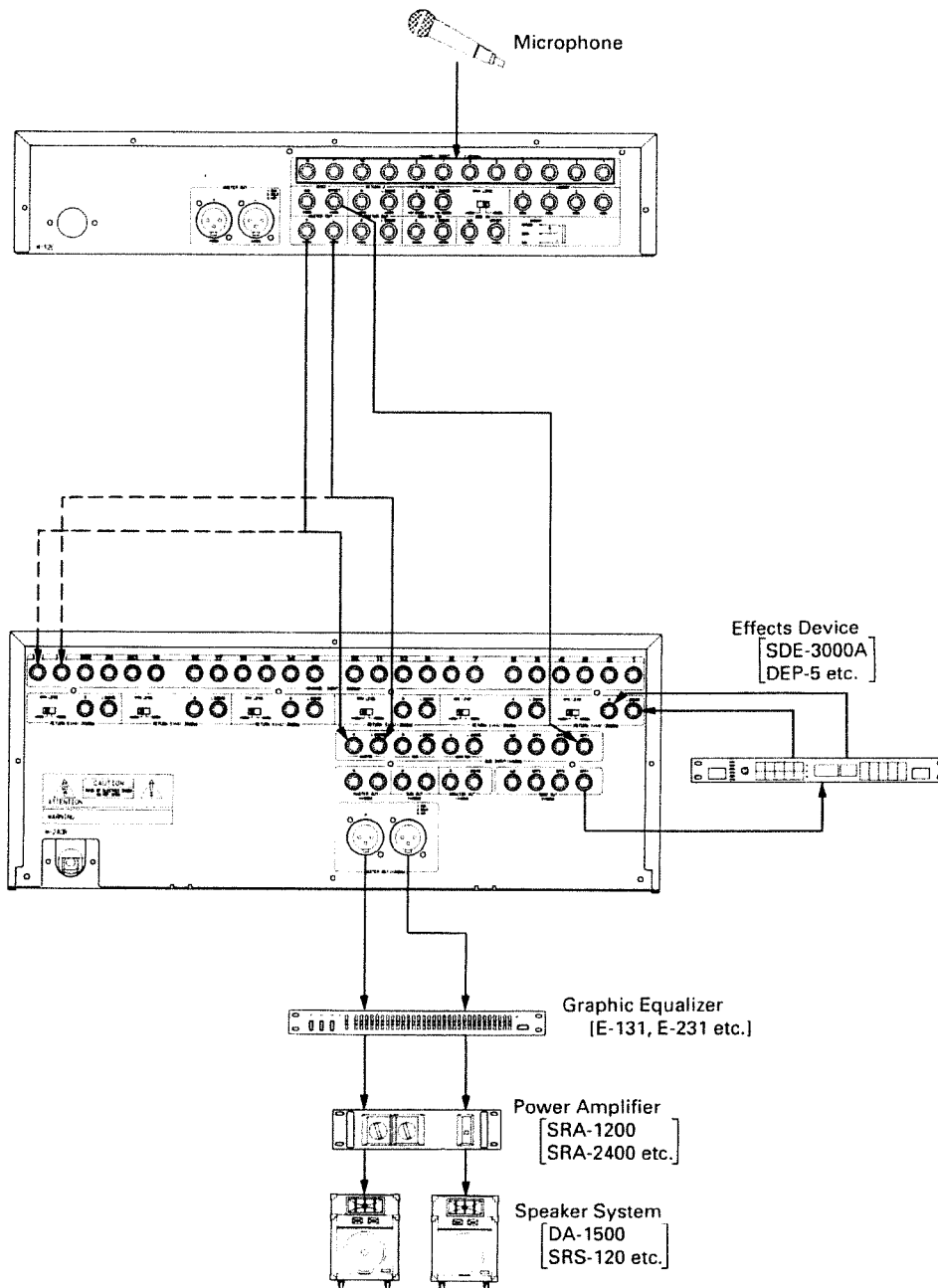

# 4 Level Diagram

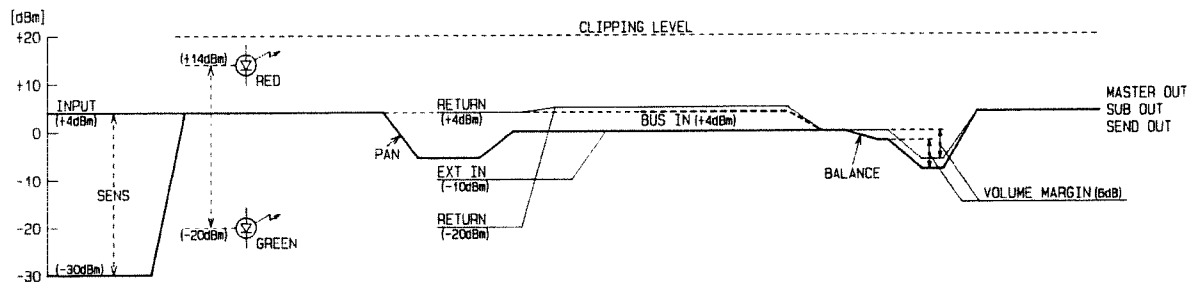
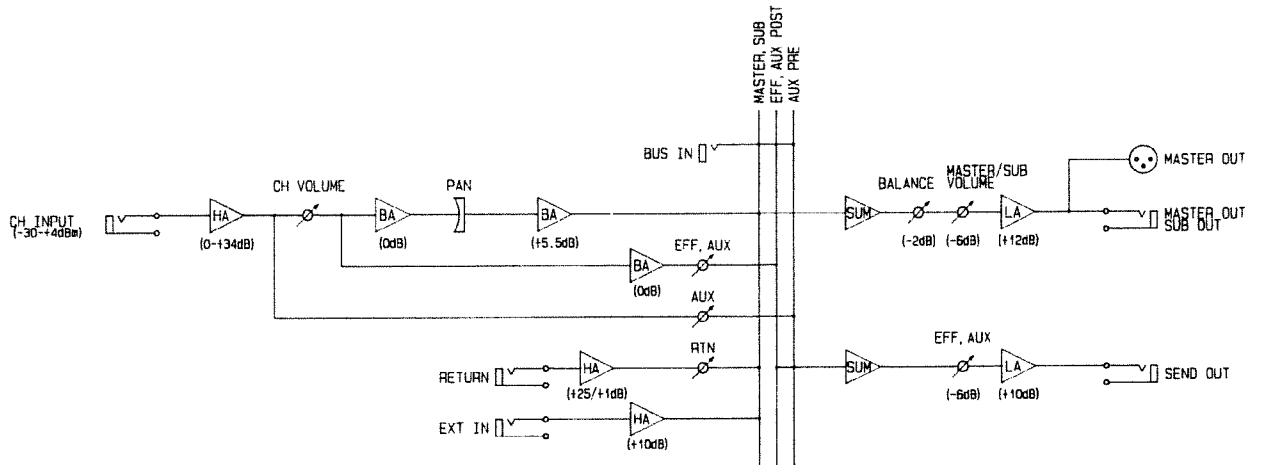

0dBm=0.775Vrms

## 5 Input/Output Standard

### ■ Input Standard

Input Jack		Input Sensitivity	Nominal Input Level	Input Impedance	Recommended Source Impedance	Type of Connector
CHANNEL INPUT (SENS=MAX)	CH 1 to 24	-36dBm (12.3mV)	-30dBm (24.5mV)	20k $\Omega$	2k $\Omega$ or less	1/4" PHONE type
RETURN	RTN 1 to 6	-26dBm (38.8mV)	-20dBm (77.5mV)	20k $\Omega$ (STEREO) 10k $\Omega$ (MONO)	2K $\Omega$ or less (STEREO) 1k $\Omega$ or less (MONO)	1/4" PHONE type
EXTERNAL IN		-16dBm (123mV)	-10dBm (245mV)	8k $\Omega$ (STEREO) 4k $\Omega$ (MONO)	1k $\Omega$ or less (STEREO) 1k $\Omega$ or less (MONO)	1/4" PHONE type
BUS IN	MASTER, SUB EFF1 to 3, AUX	-2dBm (615mV)	+4dBm (1.23V)	8k $\Omega$ (STEREO) 4k $\Omega$ (MONO)	1k $\Omega$ or less (STEREO) 1k $\Omega$ or less (MONO)	1/4" PHONE type
	MONITOR	-2dBm (615mV)	+4dBm (1.23V)	15k $\Omega$ (STEREO) 7.5k $\Omega$ (MONO)	1.5k $\Omega$ or less (STEREO) 1k $\Omega$ or less (MONO)	1/4" PHONE type

### ■ Output Standard

Output Jack	Nominal Output Level	Non-Clip Max. Output	Output Impedance	Recommended Load Impedance	Type of Connector
MASTER OUT (BALANCED)	+4dBm* <sup>1</sup> (1.23V)	+20dBm* <sup>1</sup> (7.75V)	600 $\Omega$	600 $\Omega$ or greater	XLR-3-32 type
MASTER OUT (UNBALANCED)	+4dBm (1.23V)	+20dBm (7.75V)	300 $\Omega$	3k $\Omega$ or greater	1/4" PHONE type
SUB OUT	+4dBm (1.23V)	+20dBm (7.75V)	300 $\Omega$	3k $\Omega$ or greater	1/4" PHONE type
MONITOR	+4dBm (1.23V)	+20dBm (7.75)	1k $\Omega$ (STEREO) 500 $\Omega$ (MONO)	10k $\Omega$ or greater (STEREO) 5k $\Omega$ or greater (NONO)	1/4" PHONE type
SEND (EFF1 to 3, AUX)	+4dBm (1.23V)	+20dBm (7.75V)	300 $\Omega$	3k $\Omega$ or greater	1/4" PHONE type
PHONES	—	250mW+250mW* <sup>2</sup>	60 $\Omega$	8 $\Omega$ or greater	1/4" STEREO PHONE type

@ 0dBm=0.775Vrms

\*<sup>1</sup> : 600 $\Omega$  Loaded

\*<sup>2</sup> : Both Channel 100 $\Omega$  Loaded

## 6 Specifications

Frequency Response:	10Hz to 60kHz $\pm 1$ dB (SENS = MIN)
Total Harmonic Distortion:	0.06% or less (20Hz to 20kHz at nominal output)
Noise Level (Typical):	(Input terminated with 150 $\Omega$ , IHF-A)
Equivalent Input Noise Level:	-124dBm
Residual Noise Level:	-102dBm
	[All Volume :min]
	-80dBm
	[Master Volume :max]
	[All Channel Volume :min]
	-79dBm
	[Master Volume :max]
	[All Channel Volume :max]
	[All SENS. :min]
	-68dBm
	[Master Volume :max]
	[All Channel Volume :max]
	[All SENS. :max]
@ 0dBm = 0.775 Vrms	
Crosstalk	-70dB or less (1kHz between channels) -70dB or less (1kHz between L and R)
Power Supply	AC 117V, 230V or 240V (50/60 Hz)
Power Consumption	58W (117V), 68W (230V, 240V)
Dimensions	482 (W) x 247 (D) x 180 (H) mm 19" (W) x 9"-3/4 (D) x 7"-1/16 (H) inches
Weight	9.9 kg 21.8 lbs
Accessory	Owner's Manual

\*The specifications for this product are subject to change without prior notice.

# Information

●When you need repair service, call your local Roland Service Station or the authorized Roland distributor in your country as shown below.

## U. S. A.

Roland Corp US  
7200 Dominion Circle  
Los Angeles, CA. 90040 - 3647  
U. S. A.  
☎ (213)685 - 5141

## CANADA

Roland Canada Music Ltd.  
(Head Office)  
13880 Mayfield Place  
Richmond B. C., V6V 2E4  
CANADA  
☎ (604)270 - 6626

Roland Canada Music Ltd.  
9425 Transcanadienne  
Service Rd. N.,  
St Laurent, Quebec H4S 1V3  
CANADA  
☎ (514)335 - 2009

Roland Canada Music Ltd.  
346 Watline Avenue,  
Mississauga, Ontario L4Z 1X2  
CANADA  
☎ (416)890 - 6488

## AUSTRALIA

Roland Corporation  
(Australia)Pty. Ltd.  
(Head Office)  
38 Campbell Avenue  
Dee Why West. NSW 2099  
AUSTRALIA  
☎ (02)982 - 8266

Roland Corporation  
(Australia)Pty. Ltd.  
(Melbourne Office)  
50 Garden Street  
South Yarra, Victoria 3141  
AUSTRALIA  
☎ (03)241 - 1254

## NEW ZEALAND

Roland Corporation (NZ)Ltd.  
97 Mt. Eden Road, Mt. Eden,  
Auckland 3  
NEW ZEALAND  
☎ (09)398 - 715

## UNITED KINGDOM

Roland(UK)Ltd.  
Amalgamated Drive  
West Cross Centre, Brentford,  
Middlesex TW8 9EZ,  
UNITED KINGDOM  
☎ (81)568 - 4578

## GERMANY

Roland Elektronische  
Musikinstrumente  
Handelsgesellschaft mbH.  
Oststrasse 96,  
2000 Norderstedt  
GERMANY  
☎ 040/52 60 090

## BELGIUM/HOLLAND/ LUXEMBOURG

Roland Benelux N. V.  
Houtstraat 1  
B - 2431 Oevel - Westerlo  
BELGIUM  
☎ (0032)14 - 575811

## DENMARK

Roland Scandinavia as  
Langebrogade 6  
Box 1937  
DK - 1023 Copenhagen K.  
DENMARK  
☎ 31 - 95 31 11

## SWEDEN

Roland Scandinavia as  
DanvikCenter 28 A, 2 tr.  
S - 131 30 Nacka,  
SWEDEN  
☎ 08 - 702 00 20

## NORWAY

Roland Scandinavia  
Avd. Norge  
Lilleakerveien 2  
Postboks 95 Lilleaker  
N - 0216 Oslo 2  
NORWAY  
☎ 02 - 73 00 74

## FINLAND

Fazer Musik Inc.  
Länsituulentie  
POB 169  
SF - 02101 Espoo  
FINLAND  
☎ 0 - 43 50 11

## ITALY

Roland Italy S. p. A.  
Viale delle Industrie 8  
20020 ARESE MILANO  
ITALY  
☎ 02 - 93581311

## SPAIN

Roland Electronics  
de España, S. A.  
Bolivia 239  
08020 Barcelona  
SPAIN  
☎ 93 - 308 - 1000

## SWITZERLAND

Musitronic AG  
Gerberstrasse 5, CH - 4410  
Liestal  
SWITZERLAND  
☎ 061/921 16 15

Roland CK (Switzerland) AG  
Hauptstrasse 21/Postfach  
CH - 4456 Tenniken  
SWITZERLAND  
☎ 061/98 60 55  
Repair Service by Musitronic AG

## FRANCE

Musikengro  
102 Avenue Jean - Jaures  
69007 Lyon Cedex 07  
FRANCE  
☎ (7)858 - 54 60

Musikengro  
(Paris Office)  
Centre Region Parisienne  
41 rue Charles - Fourier,  
94400 Vitry s/Seine  
FRANCE  
☎ (1)4680 86 62

## AUSTRIA

E. Dematte & Co.  
Neu - Rum Siemens - Strasse 4  
A - 6021 Innsbruck Box 591  
AUSTRIA  
☎ 43(05222)63 451

## GREECE

V. Dimitriadis & Co. Ltd.  
2 Phidiou Str., GR 106 78  
Athens  
GREECE  
☎ 1 - 3620130

## PORTUGAL

Casa Caius Instrumentos  
Musicais Lda.  
Rua de Santa Catarina 131  
Porto  
PORTUGAL  
☎ 02 - 38 44 56

## HUNGARY

Intermusica Ltd.  
Warehouse Area 'DEPO'  
Budapest. P.O. Box 3,  
2045 Torokbalint  
HUNGARY  
☎ 1868905

## BRAZIL

Oliver do Brazil S.A.  
Instrumentos Musicais  
Av. Cecl. No.578  
Centro Empresarial  
Tambore - Barueri - SP.  
CEP - 06400  
BRAZIL  
☎ (011)709 - 1267





 Roland®

---

**26045362**

UPC

26045362



1098

**Roland**