

**Km-6A**

**Mixer**

**INSTRUCTIONS**

- Please read these instructions carefully for proper operating procedures for the BOSS KM-6A.

## ■ PANEL PARTS – NAME AND FUNCTION

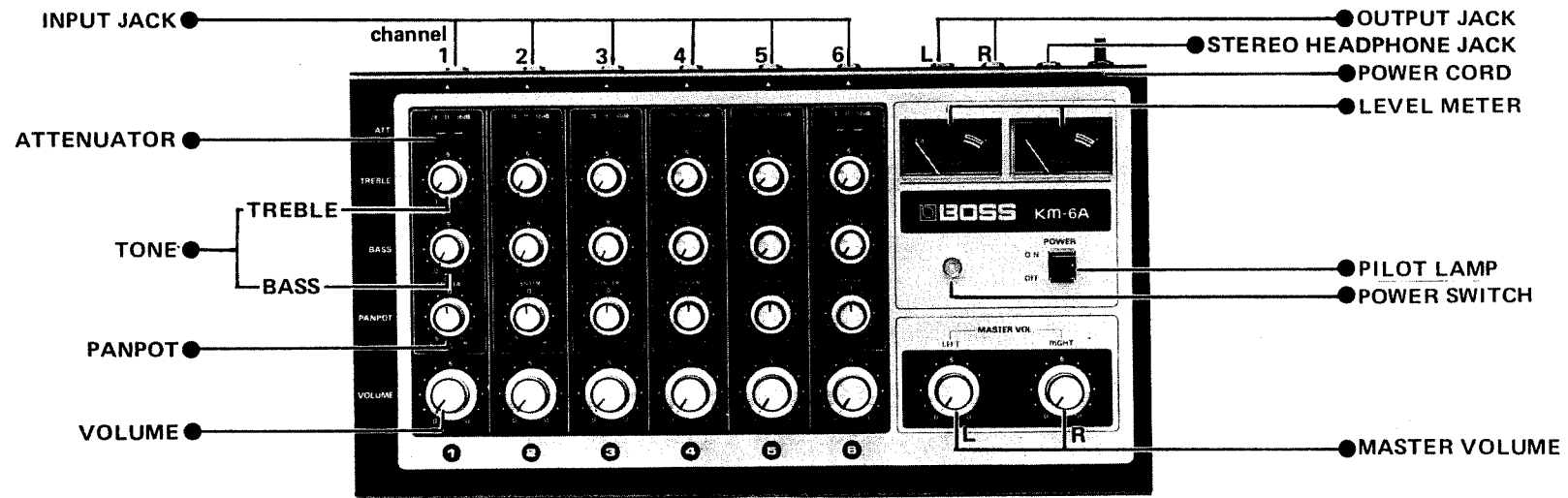

- **INPUT JACK** receives microphone and instrument for mixing.
- **OUTPUT JACK** connects mixed signal to separate right and left amplifiers, echo chamber, and others.
- **INPUT ATTENUATOR** changes input level to three steps to accord with the input device (-20/-35/-50dB). Set to -50dB for microphone, -35dB for guitar, etc. and -20dB for synthesizer.
- **TONE CONTROL** adjusts the level of treble and bass according to the instrument connected to each input jack.  
**TREBLE:** Normal tone with knob at "5" graduation. Turn knob clockwise (↻) from "5" to intensify treble, and

- counterclockwise (↺) to de-emphasize treble.  
**BASS:** Normal tone with knob at "5" graduation. Turn knob clockwise (↻) from "5" to intensify bass, and counterclockwise (↺) to de-emphasize bass.
- **PANPOT** determines the distribution of each input source in the mixed outputs. When PANPOT of an input channel is set to CENTER, the corresponding input is produced both from right and left outputs equally. When PANPOT is gradually turned clockwise (↻), the sound of the input channel gradually moves to the right output. When PANPOT is gradually

- turned counterclockwise (↺), sound of the input channel gradually moves to the left output.
- **MASTER VOLUME** controls level of mixed signal of R and L output separately. **RIGHT** controls level of RIGHT output. When the knob is turned clockwise (↻), the level is increased, and counterclockwise (↺), the level is decreased. **LEFT** controls level of LEFT output. When the knob is turned clockwise (↻), the level is increased, and counterclockwise (↺), the level is decreased.
- **VOLUME** (channel 1 – channel 6) controls the level of each input channel. To bring out any instrument or vocal sound during

- performance, turn the knob of corresponding channel clockwise (↻). To de-emphasize, turn knob counterclockwise (↺).
- **LEVEL METER** is a stereophonic VU meter that indicates the level of both output channels. If the meter pointer goes into the plus range (red section), the sound may be distorted. Best quality sound is obtained at the border of green and red section (0dB point), where the output level is -5dB.
- **STEREO HEADPHONE JACK**
- **POWER SWITCH**
- **POWER PILOT LAMP** lights up when power is switched on, indicating that the unit is correctly functioning.

**BEFORE USING KM-6A**

- KM-6A operates on AC mains. It may heat up slightly, but that is not a sign of trouble.
- While not in use, set POWER switch to OFF.
- Avoid using KM-6A in very dusty location, or under high temperature or humidity conditions.

**CONNECTING KM-6A**

**TO STEREO SOUND PRODUCER**

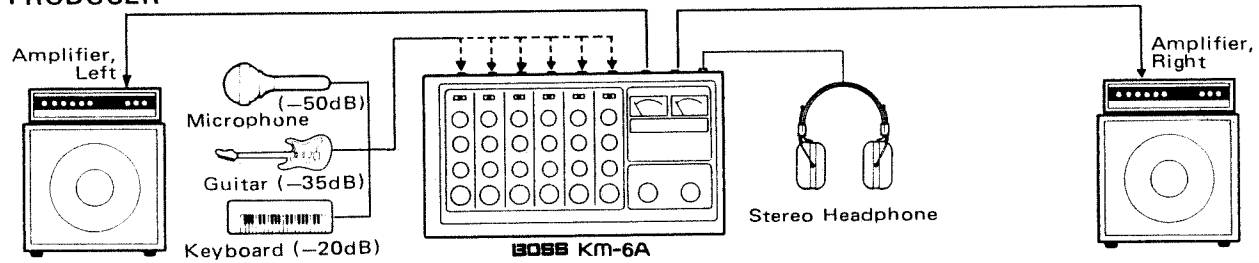

**TO GRAPHIC EQUALIZER**

For stereophonic application, use two graphic equalizers (BOSS GE-10).

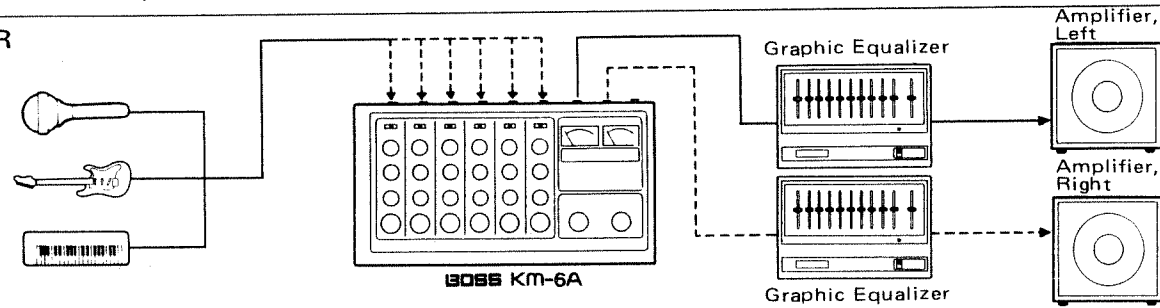

**TO ECHO CHAMBER IN MULTIPERFORMANCE**

One channel produces echo effect and the other, unmodified sound.

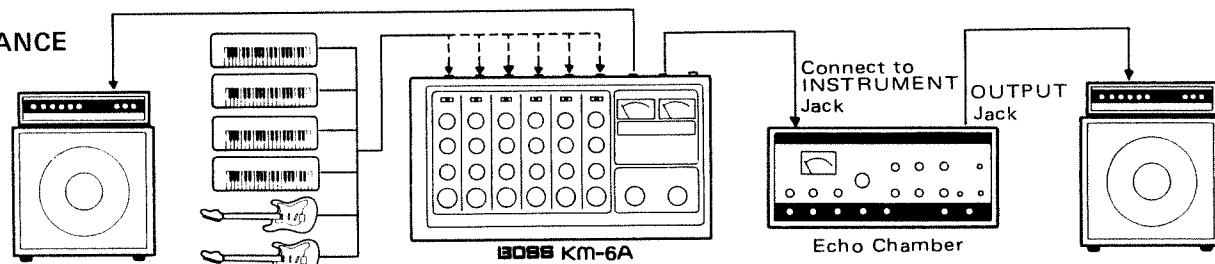

■ GOING INTO ACTION

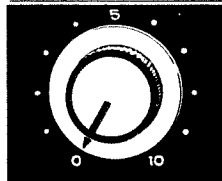

**1** After completing all cord connections, set all knobs on the panel to zero (0) position.

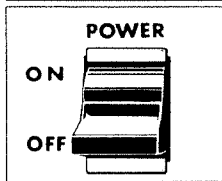

**2** Make sure that POWER switch is set to OFF, and plug power cord into outlet.

**3** KM-6A is ready to produce mixed sound.

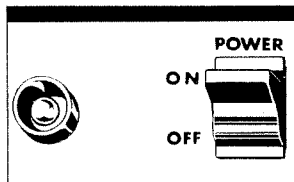

**4** Set POWER switch to ON, and power pilot lamp and level meter lamp will light up.

**5** Set attenuator switches to proper position.



◀ To -50dB when connecting microphone.

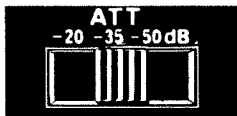

◀ To -35dB when connecting electric guitar, etc.



◀ To -20dB when connecting synthesizer, etc.

**6** Set PANPOT to proper position to obtain maximal mixing results.

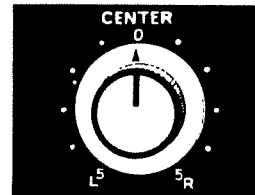

▲ To R for sound from right channel only.

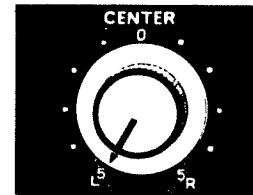

▲ To CENTER for sound from both channel outputs.

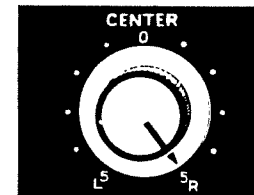

▲ To L for sound from left channel only.

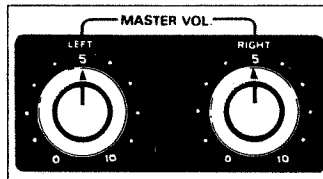

**7** Set both R and L MASTER VOLUME to "5" graduation.

**8** Set each input channel volume to proper position. Turn the knob to clockwise (↻) to intensify given instrument, and counterclockwise (↺) to de-emphasize.

- When connecting three or more instruments, adjust each channel volume to proper position and then readjust R and L MASTER VOLUME.
- VOLUME of channel not in use should be set to zero (0) position.

**9** Move tone controls, TREBLE and BASS knobs of each channel to proper position to produce optimum sound.

**10** Level meter indicates sound level of R and L outputs. If the pointer goes up into the plus range (red section), the sound may be distorted. In that case reduce the volume of each input channel or master volume. The best sound is produced at the border of green and red sections.

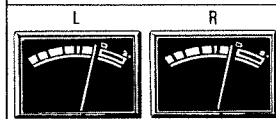

- If the sound is distorted even when total sound level is reduced with MASTER VOLUME, readjust volume of each channel separately.

■ **KM-6A MAJOR SPECIFICATIONS**

Power consumption:	2W
Input sensitivity:	-50dB/-35dB/-20dB (3.1mV/18mV/100mV)
Output level:	-5dB (562mV)
S/N ratio:	Over 63dB
Control:	Channel volume control ..... 6 Treble tone control ..... 6 Bass tone control ..... 6 Panpot ..... 6 Input attenuator (-50dB/-35dB/-20dB) ..... 6 Power switch ..... 1
Main control:	Master volume (LEFT/RIGHT) ..... 2
Output:	LEFT/RIGHT ..... 2 Stereo headphone jack (Imp. 8Ω) ..... 1
Semiconductors:	14 IC's 6 transistors 8 diodes 1 LED
Dimensions:	400(width) x 85(height) x 220(depth)mm
Weight:	3.85kg

**CAUTION:** -50dB position of Input Attenuator is low impedance exclusively for microphone. -35dB and -20dB are high impedance. Depending on output impedance of instrument you use, the sensitivity may fall when set to -50dB due to impedance mismatching.

■ **BLOCK DIAGRAM**

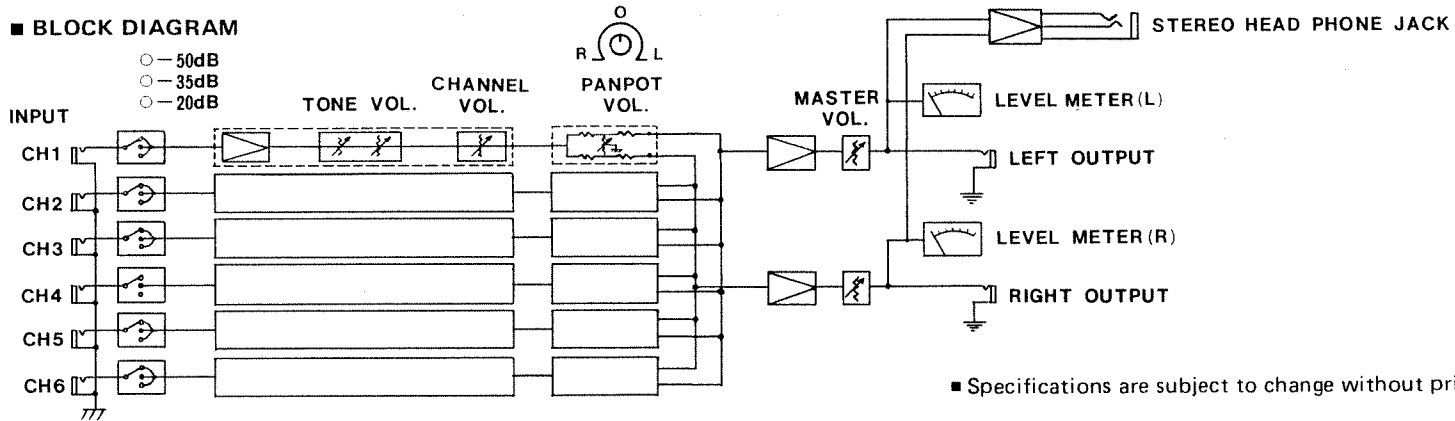

■ Specifications are subject to change without prior notice.

 Roland®

**10175**

UPC 10175



12981

