

V-KICK TRIGGER PAD **KD-120**

OWNER'S MANUAL

We'd like to take a moment to thank you for purchasing the Roland KD-120.

Before using this unit, carefully read the sections entitled: "USING THE UNIT SAFELY" (p. 2-3) and "IMPORTANT NOTES" (p. 3). These sections provide important information concerning the proper operation of the unit. Additionally, in order to feel assured that you have gained a good grasp of every feature provided by your new unit, Owner's manual should be read in its entirety. The manual should be saved and kept on hand as a convenient reference.

CONTENTS

Features.....	4
Contents of the Package.....	4
Names of the KD-120 Components	4
Setup.....	5
Connecting to the Sound Module	7
Head Adjustment.....	8
Head Replacement.....	9
Specifications.....	10

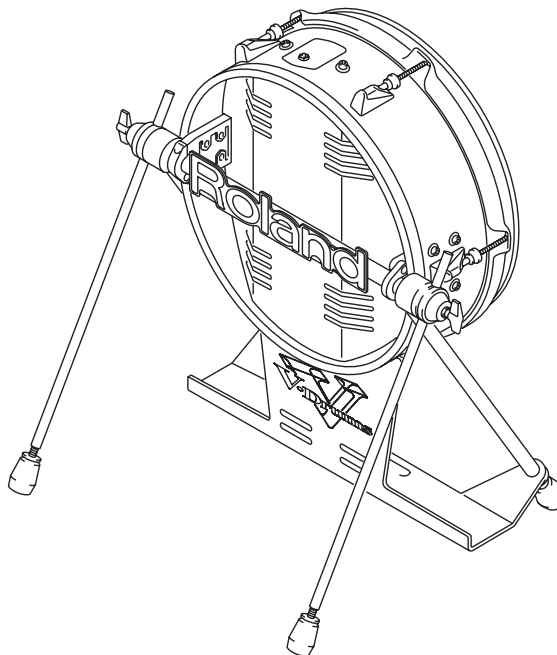

Copyright © 1998 ROLAND CORPORATION
All rights reserved. No part of this publication may be reproduced in any form without the written permission of ROLAND CORPORATION.

USING THE UNIT SAFELY

INSTRUCTIONS FOR THE PREVENTION OF FIRE, ELECTRIC SHOCK, OR INJURY TO PERSONS

About ⚠ WARNING and ⚠ CAUTION Notices

⚠ WARNING	Used for instructions intended to alert the user to the risk of death or severe injury should the unit be used improperly.
⚠ CAUTION	Used for instructions intended to alert the user to the risk of injury or material damage should the unit be used improperly. * Material damage refers to damage or other adverse effects caused with respect to the home and all its furnishings, as well to domestic animals or pets.

About the Symbols

	The ⚠ symbol alerts the user to important instructions or warnings. The specific meaning of the symbol is determined by the design contained within the triangle. In the case of the symbol at left, it is used for general cautions, warnings, or alerts to danger.
	The ⓧ symbol alerts the user to items that must never be carried out (are forbidden). The specific thing that must not be done is indicated by the design contained within the circle. In the case of the symbol at left, it means that the unit must never be disassembled.
	The ● symbol alerts the user to things that must be carried out. The specific thing that must be done is indicated by the design contained within the circle. In the case of the symbol at left, it means that the power-cord plug must be unplugged from the outlet.

ALWAYS OBSERVE THE FOLLOWING

⚠ WARNING

- Before using this unit, make sure to read the instructions below, and the Owner's Manual.

- Do not open or perform any internal modifications on the unit. (The only exception would be where this manual provides specific instructions which should be followed in order to put in place user-installable options; see p. 5.)

- Do not attempt to repair the unit, or replace parts within it (except when this manual provides specific instructions directing you to do so). Refer all servicing to your retailer, the nearest Roland Service Center, or an authorized Roland distributor, as listed on the "Information" page.

- Never use or store the unit in places that are:
 - Subject to temperature extremes (e.g., direct sunlight in an enclosed vehicle, near a heating duct, on top of heat-generating equipment); or are
 - Damp (e.g., baths, washrooms, on wet floors); or are
 - Humid; or are
 - Exposed to rain; or are
 - Dusty; or are
 - Subject to high levels of vibration.

⚠ WARNING

- Make sure you always have the unit placed so it is level and sure to remain stable. Never place it on stands that could wobble, or on inclined surfaces.

- Do not allow any objects (e.g., flammable material, coins, pins); or liquids of any kind (water, soft drinks, etc.) to penetrate the unit.

- In households with small children, an adult should provide supervision until the child is capable of following all the rules essential for the safe operation of the unit.

- Protect the unit from strong impact. (Do not drop it!)



 **CAUTION**

- Try to prevent cords and cables from becoming entangled. Also, all cords and cables should be placed so they are out of the reach of children.



- Never climb on top of, nor place heavy objects on the unit.



IMPORTANT NOTES

In addition to the items listed under “USING THE UNIT SAFELY” on page 2–3, please read and observe the following:

Placement

- Do not expose the unit to direct sunlight, place it near devices that radiate heat, leave it inside an enclosed vehicle, or otherwise subject it to temperature extremes. Excessive heat can deform or discolor the unit.

Maintenance

- For everyday cleaning wipe the unit with a soft, dry cloth or one that has been slightly dampened with water. To remove stubborn dirt, use a cloth impregnated with a mild, non-abrasive detergent. Afterwards, be sure to wipe the unit thoroughly with a soft, dry cloth.
- Never use benzine, thinners, alcohol or solvents of any kind, to avoid the possibility of discoloration and/or deformation.

Additional Precautions

- Use a reasonable amount of care when using the unit’s buttons, sliders, or other controls; and when using its jacks and connectors. Rough handling can lead to malfunctions.
- When connecting / disconnecting all cables, grasp the connector itself—never pull on the cable. This way you will avoid causing shorts, or damage to the cable’s internal elements.
- To avoid disturbing your neighbors, try to keep the unit’s volume at reasonable levels. You may prefer to use headphones, so you do not need to be concerned about those around you (especially when it is late at night).
- This instrument is designed to minimize the extraneous sounds produced when it’s played. However, since sound vibrations can be transmitted through floors and walls to a greater degree than expected, take care not to allow these sounds to become a nuisance to neighbors, especially when performing at night and when using headphones.

Features

- Kick trigger pad with net material on head for superior playing feel, and quiet response.
- The four-leg stand assures outstanding stability.
- You can also play using a twin (double kick) pedal.

Contents of the Package

□ KD-120 Pad

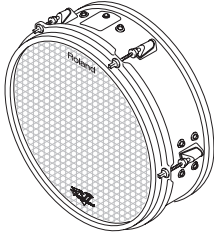

□ Leg x 2

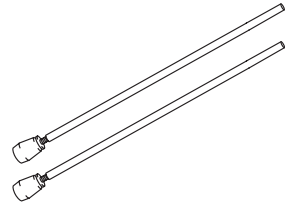

□ Stand

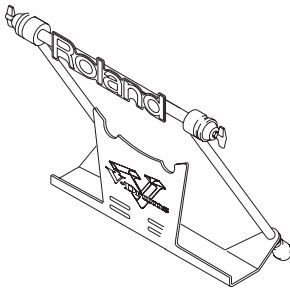

□ Beater

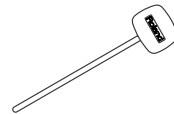

□ Connection Cable

■ Owner's Manual (this manual)



This package does not include a kick pedal. Use with a commercially available kick pedal installed on the KD-120.

Names of the KD-120 Components

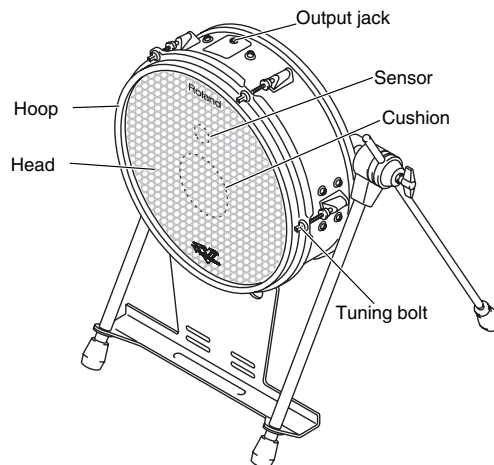
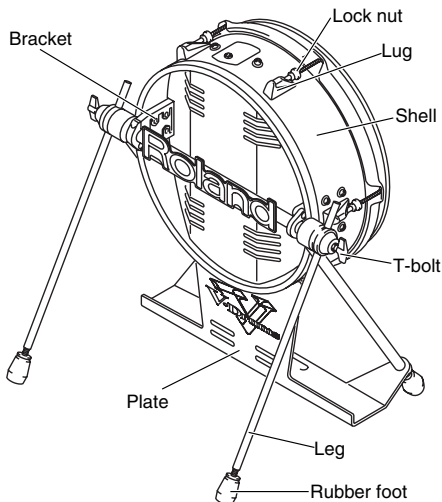

Due to the nature of the materials used in the sensor, changes in room temperature and humid may affect the sensitivity of the sensor.

Setup

Assembling the KD-120

1. Place the KD-120 pad, with the head surface facing downward, on a flat surface such as the floor.
2. Use the included drum key to loosen and remove the bolts for the brackets on the back of the KD-120 pad.
3. Mount the stand on the brackets so that the output jack for the KD-120 pad faces up. Use the bolts you removed earlier to secure the KD-120 pad to the stand, tightening the bolts with the included drum key.

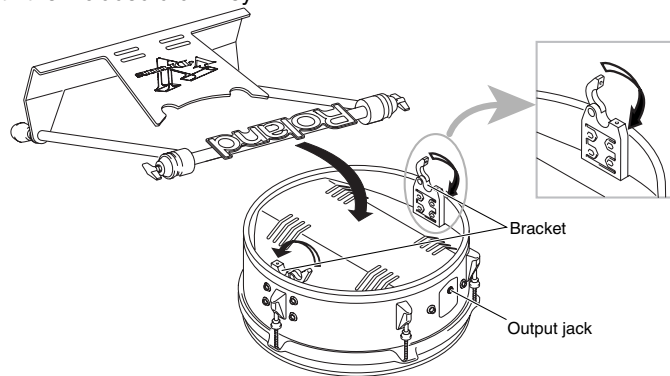

* Take care not to pinch your fingers between the KD-120 pad and the stand plate.

4. Adjust the ends of the legs to match the location where you're installing the KD-120. Adjust to use the spike legs when installing on carpeting or other soft surfaces, or the rubber legs when installing on flooring or other hard surfaces. When shipped from the factory, the stand is adjusted for using the rubber legs. If you're using the rubber legs, proceed to step 5 on the next page.

Adjusting for the Spike Legs

1. Loosen the leg nut.
2. Turn the rubber foot to adjust so that the spike portion sticks out from the rubber foot. Adjust the length of the spike to suit the location where installing and the length you prefer.

* The tip of the spike is sharp. Handle it with care.

3. Tighten the nut to secure the rubber foot in place and keep it from loosening.

* When using on flooring, the spike legs may damage the floor. Adjust to use the rubber legs.

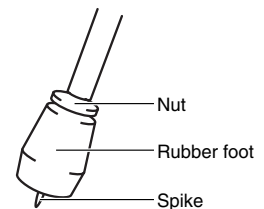

Adjusting for the Rubber Legs

1. Loosen the leg nut.
2. Turn the rubber foot to adjust so that the spike portion does not stick out from the rubber foot.
3. Tighten the nut to secure the rubber foot in place and keep it from loosening.

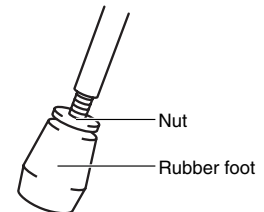

5. Loosen the T-bolts for the stand and mount the legs on the stand.
Install the legs as shown in the figure so that the ends of the legs protrude by about 2 cm.

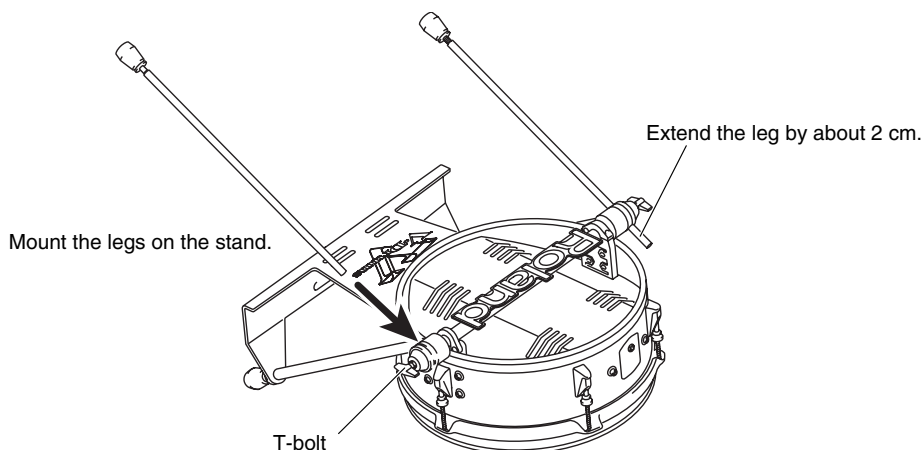

6. Tighten the T-bolts to secure the legs to the stand.
7. Lift the KD-120 and place the stand and the four legs upright.
8. Adjust the angle of the head surface so that it's at a right angle to the floor.
Use the included drum key to loosen the bracket bolts you tightened in step 3, and adjust the angle of the KD-120 pad so that the head surface is at a right angle to the floor.
9. Install the included beater on your kick pedal.
* Using a beater made of felt may result in wear to the felt. Use the special included beater or a plastic beater as the beater for the kick pedal.
10. Mount the kick pedal on the KD-120.
* Make sure there is about 1 cm of space between the two to keep the kick pedal's chain (or belt) from touching the hoop of the KD-120 pad during play. Also, if the kick pedal has no under-plate, then arrange the stand's plate section at a right angle to the floor.

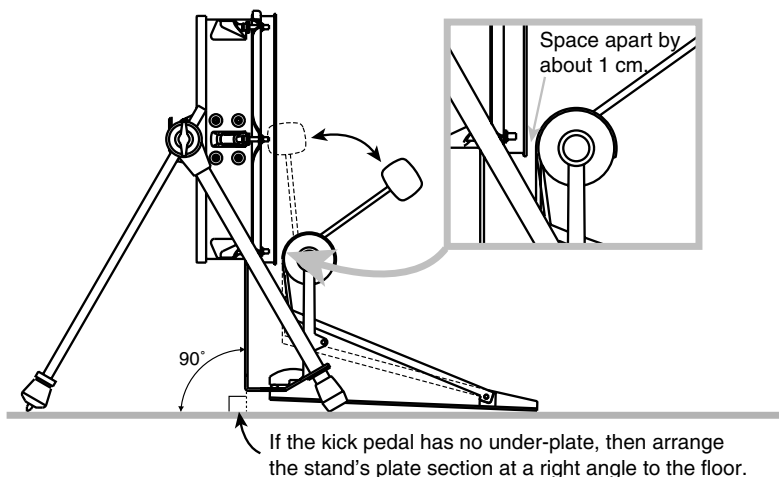

11. Make any fine adjustments necessary and tighten the stand brackets to make sure the KD-120 is secure on the stand.
Make sure the KD-120's four legs and heel portion of the kick pedal is securely on the floor by loosening the stand's T-bolts and adjusting the length of the legs.
12. Adjust the striking point for the beater.
Normally the beater's striking point is adjusted to fall at the center of the head.
Adjust the striking point so that it doesn't extend beyond the cushion on the back of the head. Moving the striking point closer to the sensor increases the sensitivity, so carry out fine adjustment to suit your preferences.

When Using a Twin (Double Kick) Pedal

With the KD-120, you can also play using a twin (double kick) pedal. Set this up so that the striking points of the two beaters fall at equal distances to the left and right of the center of the head.

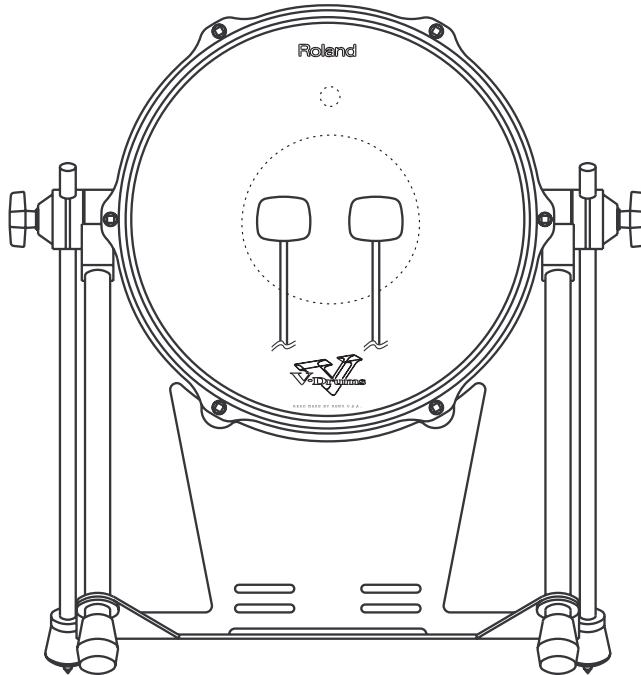

* When using a twin (double kick) pedal, as with a regular pedal, use the included beater or a plastic beater as the beater for the kick pedal.

Connecting to the Sound Module

Connecting the KD-120 to a sound module (TD-20, TD-12, etc.).



To prevent malfunction and/or damage to speakers or other devices, always turn down the volume, and turn off the power on all devices before making any connections.

- Make sure that KD-120 does not touch the drum stand or the other pads.
- The appropriate Trigger Type settings need to be made for the percussion sound module.

For instructions on making the settings, read the Owner's Manual for the relevant sound module.

Head Adjustment

The head tension of the KD-120 can be adjusted.

Adjusting the Head Tension

When adjusting, use the included drum key or the drum key for your acoustic drums. In general, a tension that produces a strike response approximately the same as an acoustic bass drum will be appropriate.

* *Head tension that is too loose may not only cause incorrect operation, but may even damage the sensor.*

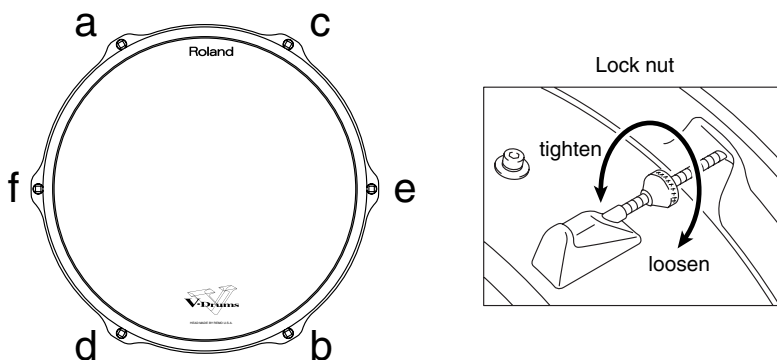

1. Check the current tension of the head.
2. Remove the kick pedal from the KD-120.
3. Loosen the lock nuts on the drum bolts.
4. Adjust bolt 'a' in the above diagram. Rotate it clockwise to tighten the head tension, or slightly counterclockwise to loosen the tension.
 - * *Fully tightening a tuning bolt at only a single location produces uneven tensioning, which may make it impossible to obtain the proper strike sensitivity and may even result in incorrect operation. Be sure to tighten each tuning bolt a little at a time, as described in the above explanation.*
5. Adjust bolt 'b' so that the tension is the same as the tension of 'a'.
6. Next adjust 'c' and 'd', and 'e' and 'f' in the same way.
7. Make sure that the head tension is even, and repeat steps 5 and 6 if you wish to make further adjustments.
 - * *On the KD-120, adjusting the head tension affects only the head response, and does not change the pitch of the sound as it would on an acoustic drum. To adjust the pitch, edit the sound parameters of the TD-20 or TD-12. For details refer to the respective owner's manual.*
 - * *The head tension will change as the instrument is used, so you should readjust when necessary.*
8. Tighten the lock nuts to prevent loosening of the tuning bolts.
9. Mount the kick pedal on the KD-120.

Head Replacement

When the head should be replaced

The head is an expendable item that eventually will wear out and need to be replaced.

Replace the head when the following occurs:

- The head surface is torn
- Slack portions remain in the head even when the head tension is properly adjusted.

Replacement heads (optional): Mesh Head (MH-12)

Replacing the Head

When replacing the head, use the included drum key or the drum key for your acoustic drums.

- * *Do not apply excessive force to the sensor and cushion located under the head. Doing so can interfere with accurate detection, and may damage it.*

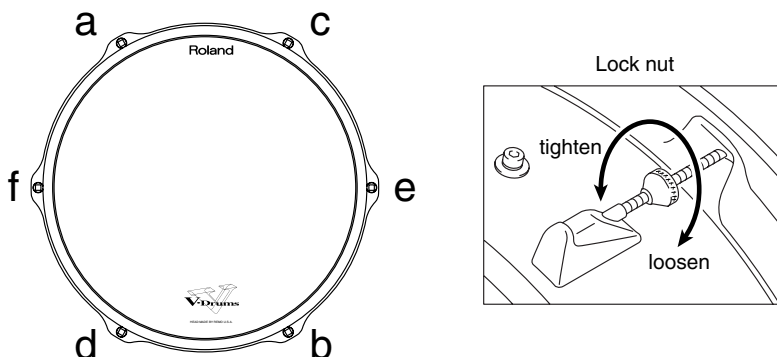

1. Loosen the lock nuts on the tuning bolts.
2. Remove all tuning bolts from the KD-120. Go around and gradually loosen each one in order (by turning it counterclockwise).
3. Remove the hoop.
4. Remove the old head.
5. Place the new head on the shell.
6. Place the hoop onto the head.
7. First lightly tighten bolt 'a' in the above diagram by rotating it clockwise. Then tighten bolt 'b' to about the same force.
8. Now lightly tighten 'c', and then 'd'. Tighten 'e' and 'f' in the same way.
9. Next adjust the tension of the head. Refer to "Adjusting the Head Tension" above.

- * *Fully tightening a tuning bolt at only a single location produces uneven tensioning, which may make it impossible to obtain the proper strike sensitivity and may even result in incorrect operation. Be sure to tighten each tuning bolt a little at a time, as described in the above explanation.*

Specifications

Pad Size:	12 inches
Dimensions:	490 (W) x 400 (D) x 500 (H) mm 19-5/16 (W) x 15-3/4 (D) x 19-11/16 (H) inches
Weight:	7.7 kg / 17 lbs
Accessories:	Owner's Manual, Connection Cable, Beater, Drum Key
Options:	Mesh Head (MH-12)

- * *In the interest of product improvement, the specifications and/or appearance of this unit are subject to change without prior notice.*

Information

When you need repair service, call your nearest Roland Service Center or authorized Roland distributor in your country as shown below.

AFRICA

EGYPT

Al Fanny Trading Office
9, EBN Hagar A1 Askalany
Street,
ARD El Golf, Heliopolis,
Cairo 11341, EGYPT
TEL: 20-2-417-1828

REUNION

Maison FO - YAM Marcel
25 Rue Jules Hermann,
Chaudron - BF79 97 491
Ste Clotilde Cedex,
REUNION ISLAND
TEL: (0262) 218-429

SOUTH AFRICA

That Other Music Shop(PTY)Ltd.
11 Melle St., Braamfontein,
Johannesburg,
SOUTH AFRICA
TEL: (011) 403 4105
FAX: (011) 403 1234

Paul Bothner(PTY)Ltd.

Royal Cape Park, Unit 24
Londonderry Road, Ottery 7800
Cape Town, SOUTH AFRICA
TEL: (021) 799 4900

ASIA

CHINA

**Roland Shanghai Electronics
Co.,Ltd.**
5F. No.1500 Pingliang Road
Shanghai 200090, CHINA
TEL: (021) 5580-0800

Roland Shanghai Electronics Co.,Ltd.

(BEIJING OFFICE)
10F. No.18 3 Section Anhuaxili
Chaoyang District Beijing
100011 CHINA
TEL: (010) 6426-5050

Roland Shanghai Electronics Co.,Ltd.

(GUANGZHOU OFFICE)
2/F., No.30 Si You Nan Er Jie
Yi Xiang, Wu Yang Xin Cheng,
Guangzhou 510600, CHINA
TEL: (020) 8736-0428

HONG KONG

Tom Lee Music Co., Ltd.
Service Division
22-32 Pun Shan Street, Tsuen
Wan, New Territories,
HONG KONG
TEL: 2415 0911

Parsons Music Ltd.

8th Floor, Railway Plaza, 39
Chatham Road South, T.S.T.,
Kowloon, HONG KONG
TEL: 2333 1863

INDIA

Rivera Digitec (India) Pvt. Ltd.
409, Nirman Kendra
Mahalaxmi Plats Compound
Off. Dr. Edwin Moses Road,
Mumbai-400011, INDIA
TEL: (022) 2495 9051

INDONESIA

PT Citra IntiRama
Jl. Cideng Timur No. 15J-150
Jakarta Pusat
INDONESIA
TEL: (021) 6324170

KOREA

Cosmos Corporation
1461-9, Seocho-Dong,
Seocho Ku, Seoul, KOREA
TEL: (02) 3486-8855

MALAYSIA

Roland Asia Pacific Sdn. Bhd.
45-1, Block C2, Jalan PJU 1/39,
Dataran Prima, 47301 Petaling
Jaya, Selangor, MALAYSIA
TEL: (03) 7805-3263

PHILIPPINES

G.A. Yupangco & Co. Inc.
339 Gil J. Puyat Avenue
Makati, Metro Manila 1200,
PHILIPPINES
TEL: (02) 899 9801

SINGAPORE

**SWEE LEE MUSIC
COMPANY PTE. LTD.**
150 Sims Drive,
SINGAPORE 387381
TEL: 6846-3676

TAIWAN

**ROLAND TAIWAN
ENTERPRISE CO., LTD.**
Room 5, 9fl. No. 112 Chung
Shan N.Road Sec.2, Taipei,
TAIWAN, R.O.C.
TEL: (02) 2561 3339

THAILAND

Theera Music Co., Ltd.
330 Soi Verg NakornKasem,
New Road, Sampantawongse,
Bangkok 10100, THAILAND
TEL: (02) 224-8821

VIETNAM

SAIGON MUSIC

DISTRIBUTOR

(TAN DINH MUSIC)

138 Tran Quang Khai Street
Dist. 1, Ho Chi Minh City
VIETNAM
TEL: (08) 848-4068

AUSTRALIA/ NEW ZEALAND

AUSTRALIA/ NEW ZEALAND

Roland Corporation

Australia Pty.,Ltd.

38 Campbell Avenue
Dee Why West. NSW 2099
AUSTRALIA

For Australia

TEL: (02) 9982 8266

For New Zealand

TEL: (09) 3098 715

CENTRAL/LATIN AMERICA

ARGENTINA

Instrumentos Musicales S.A.
Av.Santa Fe 2055
(1123) Buenos Aires
ARGENTINA
TEL: (011) 4508-2700

BARBADOS

A&B Music Supplies LTD
12 Webster Industrial Park
Wildey, St.Michael, Barbados
TEL: (246)430-1100

BRAZIL

Roland Brasil Ltda.
Rua San Jose, 780 Sala B
Parque Industrial San Jose
Cotia - Sao Paulo - SP, BRAZIL
TEL: (011) 4615 5666

CHILE

Comercial Fancy II S.A.
Rut.: 96.919.420-1
Nataniel Cox #739, 4th Floor
Santiago - Centro, CHILE
TEL: (02) 688-9540

COLOMBIA

Centro Musical Ltda.
Cr. 43 B No 25 A 41 Bododega 9
Medellin, Colombia
TEL: (574)3812529

COSTA RICA

**JUAN Bensch Instrumentos
Musicales**
Ave.1. Calle 11, Apartado 10237,
San Jose, COSTA RICA
TEL: 258-0211

CURACAO

Zeelandia Music Center Inc.
Orionweg 30
Curacao, Netherland Antilles
TEL:(305)5926866

DOMINICAN REPUBLIC

Instrumentos Fernando Giraldez
Calle Proyecto Central No.3
Ers.La Esperilla
Santo Domingo,
Dominican Republic
TEL:(809) 683 0305

ECUADOR

Mas Musica

Rumichaca 822 y Zaruma
Guayaquil - Ecuador
TEL:(593-4)2302364

EL SALVADOR

OMNI MUSIC

75 Avenida Norte y Final
Alameda Juan Pablo II,
Edificio No.4010 San Salvador,
EL SALVADOR
TEL: 262-0788

GUATEMALA

Casa Instrumental
Calzada Roosevelt 34-01,zona 11
Ciudad de Guatemala
Guatemala
TEL:(502) 599-2888

HONDURAS

Almacan Pajaro Azul S.A. de C.V.
B.O.Paz Barahona
3 Ave.11 Calle S.O
San Pedro Sula, Honduras
TEL: (504) 553-2029

MARTINIQUE

Musique & Son

Z.I.Les Mangle
97232 Le Lamantin
Martinique F.W.I.
TEL: 596 596 426860

Gigamusic SARL

10 Rte De La Folie
97200 Fort De France
Martinique F.W.I.
TEL: 596 596 715222

MEXICO

Casa Veerkamp, s.a. de c.v.
Av. Toluca No. 323, Col. Olivar
de los Padres 01780 Mexico
D.F. MEXICO
TEL: (55) 5668-6699

NICARAGUA

**Bansbach Instrumentos
Musicales Nicaragua**
Altamira D'Este Calle Principal
de la Farmacia Sta.Avenida
1 Cuadra al Lago.#503
Managua, Nicaragua
TEL: (505)277-2557

PANAMA

SUPRO MUNDIAL, S.A.
Boulevard Andrews, Albrook,
Panama City, REP. DE
PANAMA
TEL: 315-0101

PARAGUAY

**Distribuidora De
Instrumentos Musicales**
J.E. Olear y ESQ. Manduvira
Asuncion PARAGUAY
TEL: (595) 21 492147

PERU

Audionet
Distribuciones Musicales SAC
Juan Fanning 530
Miraflores
Lima - Peru
TEL: (511) 4461388

TRINIDAD

AMR Ltd
Ground Floor
Maritime Plaza
Barataria Trinidad W.I.
TEL: (868) 638 6385

URUGUAY

Todo Musica S.A.
Francisco Acuna de Figueroa
1771
C.P.: 11.800
Montevideo, URUGUAY
TEL: (02) 924-2335

VENEZUELA

Instrumentos Musicales

Allegro,C.A.

Av.las industrias edf.Guitar
import
#7 zona Industrial de Turumo
Caracas, Venezuela
TEL: (212) 244-1122

EUROPE

AUSTRIA

**Roland Elektronische
Musikinstrumente HmbH.**
Austrian Office
Eduard-Bodem-Gasse 8,
A-6020 Innsbruck, AUSTRIA
TEL: (0512) 26 44 260

BELGIUM/FRANCE/ HOLLAND/ LUXEMBOURG

Roland Central Europe N.V.
Houtstraat 3, B-2260, Oevel
(Westerlo) BELGIUM
TEL: (014) 575811

CZECH REP.

K-AUDIO
Kardasovska 626,
CZ-198 00 Praha 9,
CZECH REP.
TEL: (2) 666 10529

DENMARK

Roland Scandinavia A/S
Nordhavnsvej 7, Postbox 880,
DK-2100 Copenhagen
DENMARK
TEL: 3916 6200

FINLAND

**Roland Scandinavia As, Filial
Finland**
Elannontie 5
FIN-01510 Vantaa, FINLAND
TEL: (09) 68 24 020

GERMANY

**Roland Elektronische
Musikinstrumente HmbH.**
Oststrasse 96, 22844
Norderstedt, GERMANY
TEL: (040) 52 60090

GREECE

STOLLAS S.A.
Music Sound Light
155, New National Road
Patras 26442, GREECE
TEL: 2610 435400

HUNGARY

Roland East Europe Ltd.
Warehouse Area "DEPO" Pf.83
H-2046 Torokbalint,
HUNGARY
TEL: (23) 511011

IRELAND

Roland Ireland
G2 Calmount Park, Calmount
Avenue, Dublin 12
Republic of IRELAND
TEL: (01) 4294444

ITALY

Roland Italy S. p. A.
Viale delle Industrie 8,
20020 Arese, Milano, ITALY
TEL: (02) 937-78300

NORWAY

Roland Scandinavia Avd.
Kontor Norge
Lillekerveien 2 Postboks 95
Lilleaker N-0216 Oslo
NORWAY
TEL: 2273 0074

POLAND

MX MUSIC SP.Z.O.O.
Ul. Gibraltarska 4
PL-03664 Warszawa POLAND
TEL: (022) 679 44 19

PORTUGAL

Roland Iberia, S.L.
Portugal Office
Cais das Pedras, 8/9-1 Dto
4050-465, Porto, PORTUGAL
TEL: 22 608 00 60

ROMANIA

FBS LINES
Piata Libertatii 1,
535500 Gheorgheni,
ROMANIA
TEL: (266) 364 609

RUSSIA

MuTek
Dorozhnaya ul.3,corp.6
117 545 Moscow, RUSSIA
TEL: (095) 981-4967

SPAIN

Roland Iberia, S.L.
Paseo Garcia Faria, 33-35
08005 Barcelona SPAIN
TEL: 93 493 91 00

SWEDEN

Roland Scandinavia A/S
SWEDISH SALES OFFICE
Danvik Center 28, 2 tr.
S-131 30 Nacka SWEDEN
TEL: (0)8 702 00 20

SWITZERLAND

Roland (Switzerland) AG
Landstrasse 5, Postfach,
CH-4452 Ittingen,
SWITZERLAND
TEL: (0761) 927-8383

UKRAINE

TIK-TAC
Mira Str. 19/108
P.O. Box 180
295400 Munkachevo,
UKRAINE
TEL: (03131) 414-40

UNITED KINGDOM

Roland (U.K.) Ltd.
Atlantic Close, Swansea
Enterprise Park, SWANSEA
SA7 9FJ,
UNITED KINGDOM
TEL: (01792) 702701

MIDDLE EAST

BAHRAIN

Moon Stores
No.16, Bab Al Bahrain Avenue,
P.O.Box 247, Manama 304,
State of BAHRAIN
TEL: 17 211 005

CYPRUS

Radex Sound Equipment Ltd.
17, Diagorou Street, Nicosia,
CYPRUS
TEL: (022) 66-9426

IRAN

MOCO INC.
No.41 Nike St., Dr.Shariyati Ave.,
Roberoye Cerahe Mirdamad
Tehran, IRAN
TEL: (021) 285-4169

ISRAEL

**Halilit P. Greenspoon & Sons
Ltd.**
8 Retzif Ha'Aliya Hashnya St.
Tel-Aviv-Yafo ISRAEL
TEL: (03) 6823666

JORDAN

MUSIC HOUSE CO. LTD.
FREDDY FOR MUSIC
P. O. Box 922846
Amman 11192 JORDAN
TEL: (06) 5692696

KUWAIT

**EASA HUSAIN AL-YOUSIFI
& SONS CO.**
Abdullah Salem Street,
Safat, KUWAIT
TEL: 243-6399

LEBANON

Chahine S.A.L.
Gerge Zeidan St., Chahine
Bldg., Achrafieh, P.O.Box: 16-
5857
Beirut, LEBANON
TEL: (01) 20-1441

OMAN

TALENTZ CENTRE L.L.C.
Malatan House No.1
Al Noor Street, Ruwi
SULTANATE OF OMAN
TEL: 2478 3443

QATAR

**Al Emadi Co. (Badie Studio &
Stores)**
P.O. Box 62, Doha, QATAR
TEL: 4423-554

SAUDI ARABIA

**aDawlah Industrial
Electronics APL**
Corniche Road, Aldossary
Bldg., 1st Floor, Alkhobar,
SAUDI ARABIA

P.O.Box 2154, Alkhobar 31952
SAUDI ARABIA
TEL: (03) 898 2081

SYRIA

**Technical Light & Sound
Center**
Rawda, Abdul Qader Zajzari St.
Bldg. No. 21, P.O.BOX 13520,
Damascus, SYRIA
TEL: (011) 223-5384

TURKEY

ZUHAL DIS TICARET A.S.
Galip Dede Cad. No.37
Beyoglu - Istanbul / TURKEY
TEL: (0212) 249 85 10

U.A.E.

**Zak Electronics & Musical
Instruments Co. L.L.C.**
Zabeel Road, Al Sherouq Bldg.,
No. 14, Grand Floor, Dubai,
U.A.E.
TEL: (04) 3360715

NORTH AMERICA

CANADA

Roland Canada Music Ltd.
(Head Office)
5480 Parkwood Way
Richmond B. C., V6V 2M4
CANADA
TEL: (604) 270 6626

Roland Canada Music Ltd.

(Toronto Office)
170 Admiral Boulevard
Mississauga On L5T 2N6
CANADA
TEL: (905) 362 9707

U. S. A.

Roland Corporation U.S.
5100 S. Eastern Avenue
Los Angeles, CA 90040-2938,
U. S. A.
TEL: (323) 890 3700