

Owner's Manual

Roland Piano 5500/5600

Digital Piano HP-5500/5600

Roland has succeeded in the development of the Structured Adaptive System (SA System) which is a digital technology that analyzes and extracts the acoustic sound then synthesizes highly expressive sounds.

The HP-5500/5600 adopts the SA sound source, producing the most realistic tone colors of grand piano, harpsichord, vibraphone, etc. with extremely realistic touch sensitivity from a soft and small sound to a dynamic sound.

The MIDI Connectors are provided for setting up other MIDI devices such as sound modules, keyboard recorder.

Roland Piano

MODEL HP-5500, HP-5600 MIDI Implementation Chart

Function.....		Transmitted	Recognized	Remarks
Basic Channel	Default Changed	1 1 - 16	1 1 - 16	
Mode	Default Messages Altered	3 POLY, OMNI OFF *****	1 POLY, OMNI ON/OFF MONO(M≠1)→1, (M=1)→3	
Note Number	True voice	15 - 113 *****	0 - 127 15 - 113	
Velocity	Note ON Note OFF	○ × (9n v=0)	○ ×	v = 1-127
After Touch	Key's Ch's	× ×	× ×	
Pitch Bender		×	×	
Control Change	64 67 92 93	○	○	Damper pedal Soft pedal Tremolo Chorus
Prog Change	True #	○ (0-127) *****	○ (0-31) 0 - 31	can be ignored by power-up setting
System Exclusive		×	×	
System Common	Song Pos Song Sel Tune	× × ×	× × ×	
System Real Time	Clock Commands	× ×	× ×	
Aux Messages	Local ON/OFF All Notes OFF Active Sense Reset	× ○ (123) ○ ×	× ○ (123-127) ○ ×	
Notes		When power up, ch-1 OMNI OFF and POLY are sent. When Basic channel is changed, Mode is set to 3.		

Mode 1 : OMNI ON, POLY
Mode 3 : OMNI OFF, POLY

Mode 2 : OMNI ON, MONO
Mode 4 : OMNI OFF, MONO

○ : Yes
× : No

Roland Piano

MODEL HP-5500, HP-5600 MIDI Implementation

1. TRANSMITTED DATA

Status	Second	Third	Description
1001 nnnn	0kkk kkkk	0000 0000	Note OFF
1001 nnnn	0kkk kkkk	0vvv vvvv	Note ON kkkkkk = 15 - 112 vvvvvv = 1 - 127
1011 nnnn	0100 0000	0111 1111	Damper ON
1011 nnnn	0100 0000	0000 0000	Damper OFF
1011 nnnn	0100 0011	0111 1111	Soft ON
1011 nnnn	0100 0011	0000 0000	Soft OFF
1011 nnnn	0101 1100	0111 1111	Tremolo ON
1011 nnnn	0101 1100	0000 0000	Tremolo OFF
1011 nnnn	0101 1101	0111 1111	Chorus ON
1011 nnnn	0101 1101	0000 0000	Chorus OFF
1100 nnnn	0ppp pppp		Program Change pppppp = 0 - 127
1011 nnnn	0111 1011	0000 0000	ALL NOTES OFF
1011 nnnn	0111 1100	0000 0000	OMNI OFF
1011 nnnn	0111 1111	0000 0000	POLY ON
1111 1110			Active Sensing

- Notes:
- nnnn = MIDI Channel number (0000 - 1111), ch-1 = 0000. Refer to Section 3.
 - #1 The range may be changed by the transposition. Refer to Section 4.
 - #2 Refer to Section 5.
 - #3 Refer to Section 6.
 - #4 When all keys on the keyboard are released, the ALL NOTES OFF (15h, 87h, 0) is sent.
 - #5 When power is first applied or Basic Channel is changed, OMNI OFF and POLY ON are sent in the Basic Channel.

2. RECOGNIZED RECEIVE DATA

Status	Second	Third	Description
1000 nnnn	0kkk kkkk	0vvv vvvv	Note OFF, velocity ignored
1001 nnnn	0kkk kkkk	0000 0000	Note OFF
1001 nnnn	0kkk kkkk	0vvv vvvv	Note ON kkkkkk = 0 - 127 (15 - 113) vvvvvv = 1 - 127
1011 nnnn	0100 0000	0vvv vvvv	Damper OFF vvvvvv = 0 - 63 Damper ON vvvvvv = 64 - 127
1011 nnnn	0100 0011	0vvv vvvv	Soft OFF vvvvvv = 0 - 63 Soft ON vvvvvv = 64 - 127
1011 nnnn	0101 1100	0vvv vvvv	Tremolo OFF vvvvvv = 0 - 63 #2 Tremolo ON vvvvvv = 64 - 127 #2
1011 nnnn	0101 1101	0vvv vvvv	Chorus OFF vvvvvv = 0 - 63 #2 Chorus ON vvvvvv = 64 - 127 #2
1100 nnnn	0ppp pppp		Program Change pppppp = 0 - 31
1011 nnnn	0111 1011	0000 0000	ALL NOTES OFF
1011 nnnn	0111 1100	0000 0000	OMNI OFF
1011 nnnn	0111 1101	0000 0000	OMNI ON
1011 nnnn	0111 1110	0000 0000	MONO ON
1011 nnnn	0111 1111	0000 0000	POLY ON
1111 1110			Active Sensing

- Notes:
- #1 Note numbers outside of the range 15 - 113 are transposed to the nearest octave inside this range. The transposition function does not affect the recognized NOTE numbers.
 - #2 If the power has been applied while the PIANO 1 switch being held down, this message is ignored.
 - #3 If the power has been applied while the PIANO 1 switch being held down, this message is ignored.
- Received Program Change messages are assigned as follows. The program numbers 32 - 127 are ignored.

Prog #	Voice	CHORUS	TREMOLO
0	PIANO 1	OFF	OFF
1	PIANO 2	OFF	OFF
2	PIANO 3	OFF	OFF
3	HARPSICHOORD	OFF	OFF
4	CLAVI	OFF	OFF
5	VIBRAPHONE	OFF	OFF
6	E.PIANO 1	OFF	OFF
7	E.PIANO 2	OFF	OFF
8	PIANO 1	ON	OFF
9	PIANO 2	ON	OFF
10	PIANO 3	ON	OFF
11	HARPSICHOORD	ON	OFF
12	CLAVI	ON	OFF
13	VIBRAPHONE	ON	OFF
14	E.PIANO 1	ON	OFF
15	E.PIANO 2	ON	OFF
16	PIANO 1	OFF	ON
17	PIANO 2	OFF	ON
18	PIANO 3	OFF	ON
19	HARPSICHOORD	OFF	ON
20	CLAVI	OFF	ON
21	VIBRAPHONE	OFF	ON
22	E.PIANO 1	OFF	ON
23	E.PIANO 2	OFF	ON
24	PIANO 1	ON	ON
25	PIANO 2	ON	ON
26	PIANO 3	ON	ON
27	HARPSICHOORD	ON	ON
28	CLAVI	ON	ON
29	VIBRAPHONE	ON	ON
30	E.PIANO 1	ON	ON
31	E.PIANO 2	ON	ON

If the power has been applied while the PROGRAM CHANGE switch being held down, received Program Change messages don't affect TREMOLO and CHORUS and are assigned as follows. The program numbers 0 - 127 are ignored.

Prog #	Voice
0	PIANO 1
1	PIANO 2
2	PIANO 3
3	HARPSICHOORD
4	CLAVI
5	VIBRAPHONE
6	E.PIANO 1
7	E.PIANO 2

When the Program Change message is recognized, the VOICE will be not change to the new VOICE until all the notes are turned OFF and Damper is turned OFF.

#4 When the ALL NOTES OFF is recognized, all the notes which have been turned ON only by MIDI 1h note ON messages are turned OFF. However, if the damper pedal is pressed or the damper ON message has been recognized, these ON notes will be not turned OFF until the damper pedal is released or the Damper OFF message is received.

#5 These Mode Messages (2nd byte = 123 - 127) are also recognized as ALL NOTES OFF.

Mode Messages are recognized as follows:

POLY ON (127)	MONO ON (126)	MONO ON (126)
nnnn	nnnn	nnnn
OMNI OFF (124)	OMNI = OFF	OMNI = ON
POLY	POLY	POLY
OMNI ON (125)	OMNI = ON	OMNI = ON
POLY	POLY	POLY

3. BASIC CHANNEL SETTING

When the power is first applied, the Basic Channel is normally set to 1, and the receiver is set to the MODE 1 (OMNI ON, POLY ON). However, the Basic Channel may be changed when the following key on the keyboard is pressed while the TRANSPOSE switch being held down. The receiver will be set to the MODE 3 (OMNI OFF, POLY ON).

Key	Basic Channel	OMNI
Power-up	1	ON
A 0	1	OFF
A# 0	2	OFF
B 0	3	OFF
C 1	4	OFF
C# 1	5	OFF
D 1	6	OFF
D# 1	7	OFF
E 1	8	OFF
F 1	9	OFF
F# 1	10	OFF
G 1	11	OFF
G# 1	12	OFF
A 1	13	OFF
A# 1	14	OFF
B 1	15	OFF
C 2	16	OFF

4. TRANSPOSE

When the power is first applied, the default transposition is set at 0. The following chart shows the relation of the key position and transposed value. (While the TRANSPOSE switch being held down.)

Key	Transposed value (semi tones)	Transmitted note range
power up	0	21 - 108
F# 6	-6	15 - 102
G 6	-5	16 - 103
G# 6	-4	17 - 104
A 6	-3	18 - 105
A# 6	-2	19 - 106
B 6	-1	20 - 107
C 7	0	21 - 108
C# 7	1	22 - 109
D 7	2	23 - 110
D# 7	3	24 - 111
E 7	4	25 - 112
F 7	5	26 - 113

5. TREMOLO, CHORUS TRANSMISSION

When the CHORUS switch or the TREMOLO switch is pressed while the PROGRAM CHANGE switch being held down, the function's ON or OFF message is sent. And also, if the power has been applied while the PROGRAM CHANGE switch being held down, the function's ON or OFF message can be sent by only pressing the TREMOLO switch or the CHORUS switch.

6. PROGRAM CHANGE TRANSMISSION

When one of the following switches is pressed while holding the EXT PROG CHANGE switch down, the PROGRAM CHANGE message can be sent by only pressing following switches.

Switch	Prog #
PIANO 1	0
PIANO 2	1
PIANO 3	2
HARPSICHOORD	3
CLAVI	4
VIBRAPHONE	5
E.PIANO 1	6
E.PIANO 2	7

The following table shows the GROUP, BANK and NUMBER values related with key position which is set while the TRANSPOSE switch being held down.

Key	Related value
A 3	GROUP 4
B 3	GROUP 5
F# 2	BANK 1
G# 2	BANK 2
A# 2	BANK 3
C# 3	BANK 4
D# 3	BANK 5
F# 3	BANK 6
G# 3	BANK 7
A# 3	BANK 8
F 2	NUMBER 1
G 2	NUMBER 2
A 2	NUMBER 3
B 2	NUMBER 4
C 3	NUMBER 5
D 3	NUMBER 6
E 3	NUMBER 7
F 3	NUMBER 8

When one of the above-mentioned keys is pressed while the TRANSPOSE switch being held down, a PROGRAM CHANGE message will be transmitted. The transmitted program change numbers are related with the GROUP, BANK and NUMBER values as follows.

GROUP A	NUMBER	1	2	3	4	5	6	7	8
BANK	0	1	2	3	4	5	6	7	8
2	8	9	10	11	12	13	14	15	16
3	16	17	18	19	20	21	22	23	24
4	24	25	26	27	28	29	30	31	32
5	32	33	34	35	36	37	38	39	40
6	40	41	42	43	44	45	46	47	48
7	48	49	50	51	52	53	54	55	56
8	56	57	58	59	60	61	62	63	64

GROUP B	NUMBER	1	2	3	4	5	6	7	8
BANK	1	2	3	4	5	6	7	8	9
1	64	65	66	67	68	69	70	71	72
2	72	73	74	75	76	77	78	79	80
3	80	81	82	83	84	85	86	87	88
4	88	89	90	91	92	93	94	95	96
5	96	97	98	99	100	101	102	103	104
6	104	105	106	107	108	109	110	111	112
7	112	113	114	115	116	117	118	119	120
8	120	121	122	123	124	125	126	127	128

Important Notes

Location

- Operating the HP-5500/5600 near a neon or fluorescent lamp may cause noise interference. If so, change the position or angle of the piano.
- Avoid using the HP-5500/5600 in excessive heat or humidity or where it may be affected by direct sunlight or dust.

Power Supply

- The appropriate power supply for this instrument is shown on its name plate. Please be sure that the voltage system in your country meets this.
- This instrument might generate heat while operating, but there is no need to worry about it.

Cleaning

- Use a soft cloth and mild detergent for cleaning.
- Do not use solvents such as paint thinner.

* This owner's manual covers both the HP-5500/5600. The HP-5600's front panel is shown here, but it is exactly the same as the HP-5500's.

Bescheinigung des Herstellers / Importeurs
Hiermit wird bescheinigt, daß der/die/das ROLAND PIANO HP-5500/5600 <small>(Gerät, Typ Bezeichnung)</small>
in Übereinstimmung mit den Bestimmungen der Amtsbl. Vfg 1046 / 1984 <small>(Anzahlverfügung)</small>
funk-entstört ist. Der Deutschen Bundespost wurde das Inverkehrbringen dieses Gerätes angezeigt und die Berechtigung zur Überprüfung der Serie auf Einhaltung der Bestimmungen eingeräumt.
Roland Corporation Osaka / Japan <small>Name des Herstellers/Importeurs</small>

■ Panel Descriptions

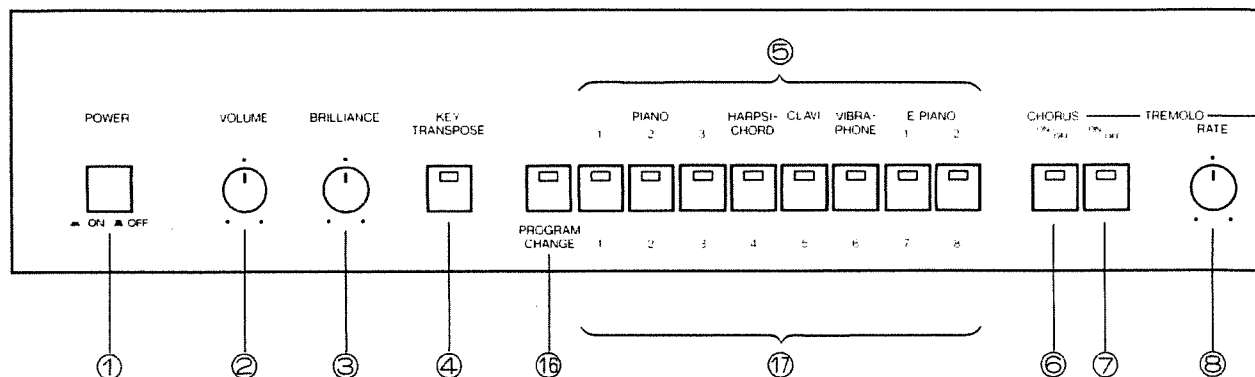

Front Panel

- ① **Power Switch**
- ② **Volume Knob**
- ③ **Brilliance Knob**
As you rotate this knob clockwise (↻), the tone color will be brighter, and counter-clockwise (↺) mellow. Normally this is set to the center.
- ④ **Key Transpose Button**
While holding this button down, press the Key (F# to F) to which you wish to transpose.
- ⑤ **Tone Selectors**
By pressing one of these buttons, you can select a tone color you like. Just select one tone color at a time.
PIANO 1, 2, 3
HARPSICHORD
CLAVI
VIBRAPHONE
ELECTRIC PIANO 1, 2
- ⑥ **Chorus Button**
Turn this button on (the indicator lights up), and expansive chorus sounds will be obtained.
- ⑦ **Tremolo Button**
Press this button (the indicator lights up), and a tremolo effect is obtained.

- ⑧ **Tremolo Rate Knob**
This knob is to adjust the rate of the tremolo effect. Rotating this clockwise (↻) quickens the rate.
- ⑨ **Headphones Jack**
Standard stereo headphones can be connected. The sound from the built-in speaker stops automatically on connecting the headphones. Please adjust the volume with the Volume Knob.

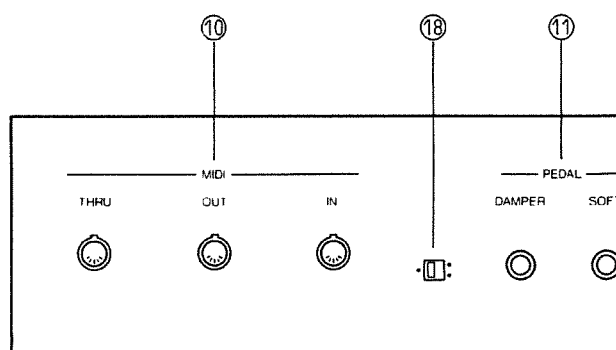
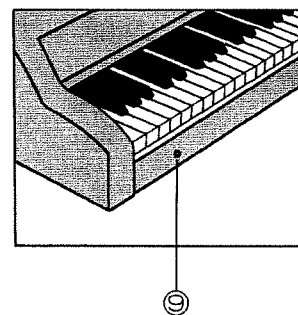

- **NOTE**
Even if you select a new tone color while playing the HP-5500/5600, the current tone color remains (= the indicator flashes) until you release all the keys and the damper pedal (= the indicator lights steadily).

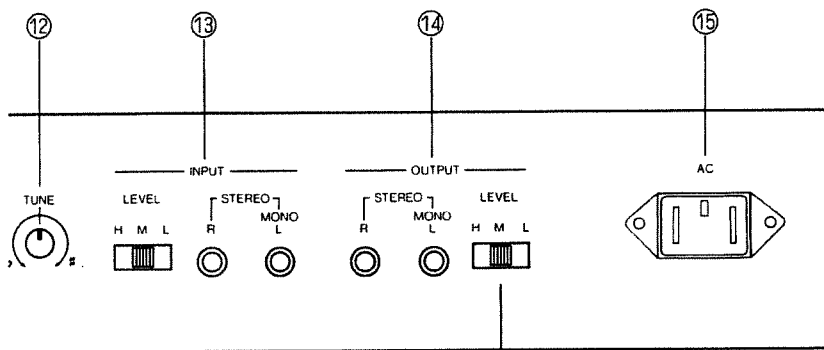
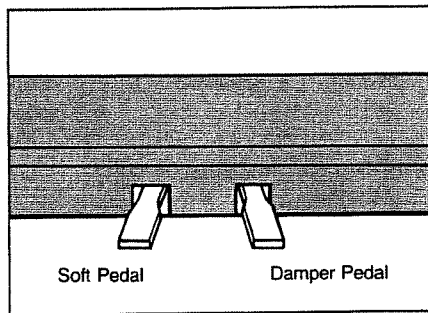
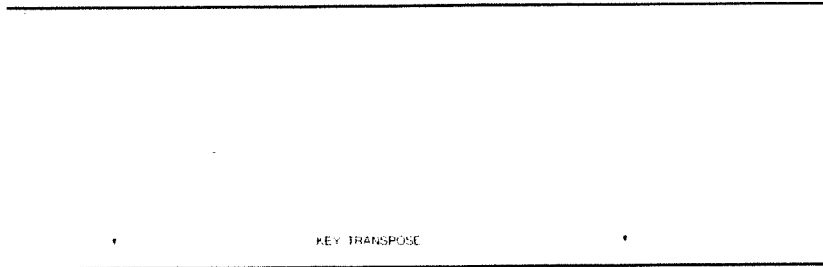

Keyboard Amp.	M/H
Audio Amp.	H
Recording Unit	H
P.A. Mixer	L/M/H
Guitar Amp.	L/M
etc.	etc.

Rear Panel

⑩ MIDI (Musical Instrument Digital Interface)

MIDI is an international standard of the electronic musical instruments. By connecting the devices featuring MIDI Buses, their musical messages can be communicated by means of digital signal. (Refer to the separate book "MIDI")

⑪ Pedal Jacks (Damper, Soft)

These jacks are for connecting the cords of the stand's pedals. These will function just like a damper pedal or a soft pedal of a usual piano.

⑫ Tune Knob

This is used to tune the HP-5500/5600 to other musical instrument. At its center position, A = 442Hz.

* The HP-5500/5600 itself never gets out of tune, therefore tuning is not necessary.

⑬ External Input Jacks

To this jack, you can connect a Rhythm Machine such as the CR-8000, TR-707 or Bass Line TB-303, etc.

* Select H, M or L position depending on the input level. (Set this switch to L if the input level is low, and H if high.)

⑭ Output Jacks

⑮ AC Socket

* Make sure that the HP-5500/5600 is turned off, then connect the power cable to this AC socket.

The buttons ⑯ and ⑰ are exclusively used to control external MIDI instruments. (Refer to the next page.)

The selector switch ⑱ should usually be set to the "." position. Just when the PR-800 (Recorder Plus) and the PB-300 (Rhythm Plus), set it to "·".

■ Setup with Audio Equipment

Before setting up the stereo amplifier, be sure to turn down the volume.

Set up the piano with the stereo amplifier as shown right and set the Output Level Switch on the piano to the H position. Then adjust the volume as you play the keyboard.

NOTE:

If the excessive power is sent from the piano, the speaker may break.

To turn off the speaker of the piano, connect the stereo headphones to the Headphones Jack.

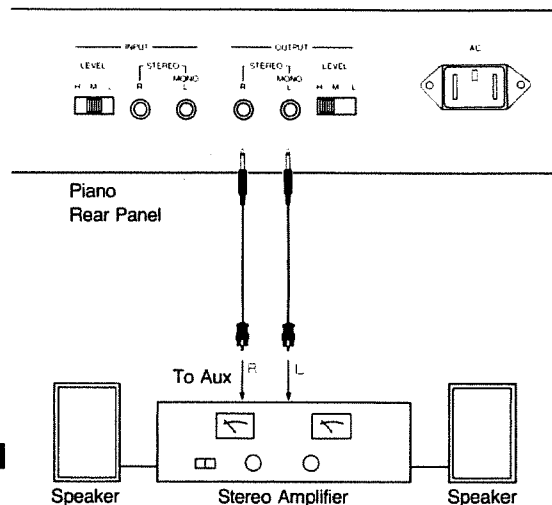

■ External Connections using MIDI

The HP-5500/5600 is the finest electronic piano on its own, but MIDI allows even more sophisticated performance by connecting other MIDI device.

* Please read the separate book "MIDI".

■ Example Connections

1) Setup with MIDI Sound Module

In this setup, both the piano and the MIDI Sound Module can be simultaneously played.

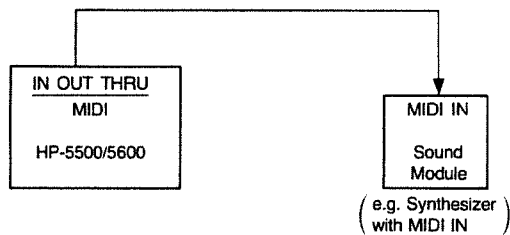

3) Setup with MIDI Keyboard Recorder

The Keyboard Recorder can record what is played on the Piano and play it back.

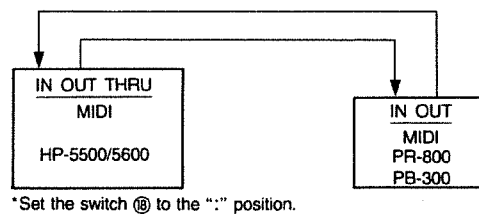

2) Controlling Piano by MIDI Keyboard

The piano can be played by other MIDI keyboard.

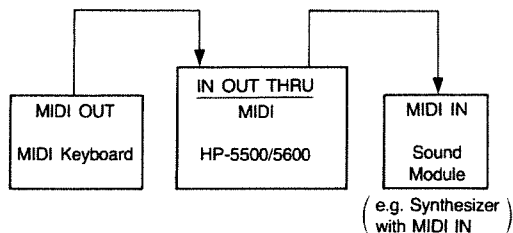

MIDI Messages of the HP-5500/5600

The HP-5500/5600 can receive or transmit the following MIDI messages.

- Key On/Off (including Velocity)
- Channel
- Program Change
- Damper
- Soft
- Chorus
- Tremolo

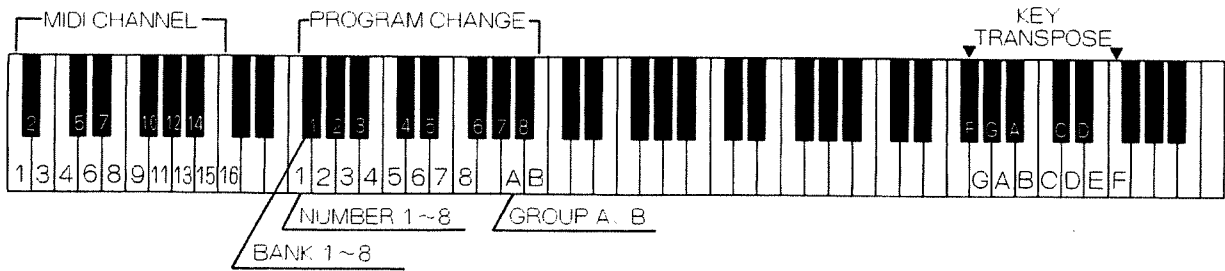

1. Changing MIDI Channels

At power up, the piano defaults to Channel 1 and OMNI ON.

While holding the Transpose Button ④ down, press the appropriate key for the MIDI Channel (1 to 16).

* MIDI does not allow to set different channel numbers for receive and transmit. That is, the MIDI channel you have set is both for receiving and sending messages.

* Changing MIDI channels will automatically set OMNI OFF.

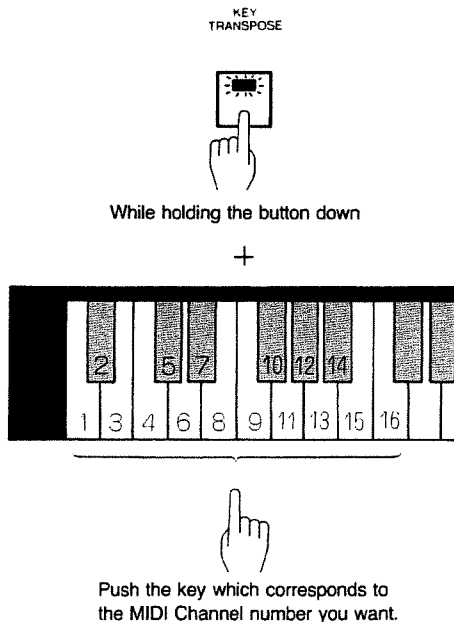

2. Program Change Message

a. Sending Program Change 1 to 128

To send the program change number 1 to 8, use the Program Change Button ⑩ and the corresponding Number Button ⑪. While holding the Button ⑩ down, push the appropriate Number Button ⑪ (1 to 8).

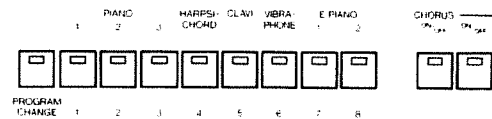

To send the program change number 1 to 128, use the Key Transpose Button ④ and appropriate keys on the keyboard. See Table 1 on page 8 to find out the Group, Bank and Number, then the keyboard shown below to find out the keys to be used. The black keys F# to A# (1 to 8) can be used for Bank, the white keys F to F (1 to 8) for Number. The white keys A and B are used for Group.

e.g.) To Send Program change No. 102

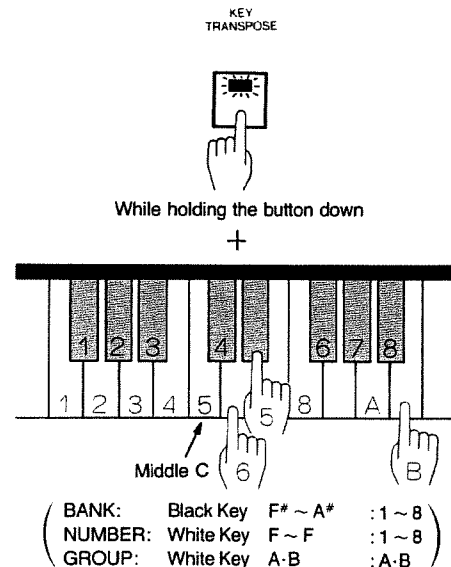

Table 1

	NO. BANK	1	2	3	4	5	6	7	8
A	1	1	2	3	4	5	6	7	8
	2	9	10	11	12	13	14	15	16
	3	17	18	19	20	21	22	23	24
	4	25	26	27	28	29	30	31	32
	5	33	34	35	36	37	38	39	40
	6	41	42	43	44	45	46	47	48
	7	49	50	51	52	53	54	55	56
	8	57	58	59	60	61	62	63	64
B	1	65	66	67	68	69	70	71	72
	2	73	74	75	76	77	78	79	80
	3	81	82	83	84	85	86	87	88
	4	89	90	91	92	93	94	95	96
	5	97	98	99	100	101	102	103	104
	6	105	106	107	108	109	110	111	112
	7	113	114	115	116	117	118	119	120
	8	121	122	123	124	125	126	127	128

b. Receiving Program Change 1 to 32

The piano can receive Program Change numbers 1 to 32. This enables to externally select any of the 32 patches (8 tone colors and 4 kinds of chorus and tremolo combinations).

3. Control Change

The HP-5500/5600 can send and receive Control Change messages. Control Change messages include Damper Pedal and Soft Pedal ON/OFF, and Chorus and Tremolo ON/OFF. To send ON/OFF messages of Tremolo and Chorus, push the Button ⑥ and ⑦ while holding the Button ⑩ down.

4. Key On/Off & Damper Messages

These two messages will be received without taking any special operations.

NOTE:

When the Transpose function is used, the note number sent from the MIDI OUT will be changed. The Transpose function does not affect the Key Information received from MIDI IN.

5. Changing MIDI Functions

The HP-5500/5600 does not feature the selector switch for MIDI functions, but you can easily change MIDI functions (as shown in Table 2) by taking either of the following procedures.

- 1) Turn the piano on while holding the PIANO 1 Button down.
- 2) Turn the piano on while holding the Program Change Button ⑩ down.

Table 2

	Transmit		Receive		
	Program Change	Chorus, Tremolo On/Off	Program Change	Chorus, Tremolo On/Off	
1)	Usual Transmit	Usual Transmit	Not recognized	Not recognized	To ignore Program Change, Chorus and Tremolo.
2)	1 to 8 are transmitted by pushing any of the Tone Selector Button.	By pushing the Button ⑥ and ⑦, the Chorus and Tremolo are transmitted.	1 to 8 are received. Chorus and Tremolo are not affected.	Recognized	To record or play with MIDI recorder.

■ Key Transpose

By using the appropriate key, you can shift the pitch of the entire keyboard up to the perfect fourth upward or diminish fifth downward.

<Operation>

While holding the Transpose Button ④ down, press the key (F# to F) to which you wish to transpose.

While the button is being held down, the indicator flashes. When the button and the key are both released, the indicator will glow steadily showing that transposition is done.

Pressing the Transpose Button again will return the piano to the normal condition (C key.)

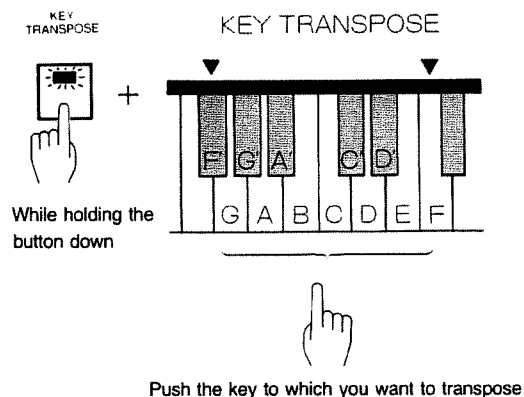

■ Specifications

Keyboard	88 keys, 16 voice polyphonic
Tone Selector buttons	Piano 1, 2, 3, Harpsichord, Clavi, Vibraphone, Electric Piano 1, 2.
Effect	Chorus On/Off, Tremolo On/Off, Tremolo Rate
Performance Control	Volume, Brilliance, Tune (± 15 cent), Key Transpose Program Change
Jacks	Output (Mono, Stereo), Ext. Input, Phones, Damper Pedal, Soft Pedal, MIDI IN (DIN socket), MIDI OUT (DIN socket), MIDI THRU (DIN socket)
Selector switches	Output level Selector, Input Level Selector
Speakers	25cm \times 2 12cm \times 2 Dome Tweeter \times 2
Output Power	30W \times 2
Consumption	Shown on the name plate.
Finish	Rosewood (HP-5500), Walnut urethane coated (HP-5600)
Dimensions	1383(W) \times 546(D) \times 825(H) mm 54 $\frac{7}{16}$ " \times 21 $\frac{1}{2}$ " \times 32 $\frac{1}{2}$ "
Weight	90kg/198lb 11 oz
Accessories	Music Rest, Power Cord, Stand ^{KS-5500/5600}

*Specifications are subject to change without notice.

■ Sound Range Diagram

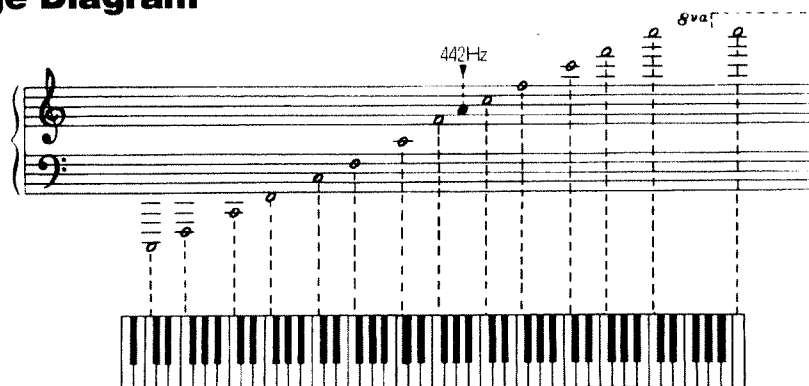

■ Options

- Headphones RH-10
- Chair W-5

STAND ASSEMBLY

ASSEMBLY DRAWING

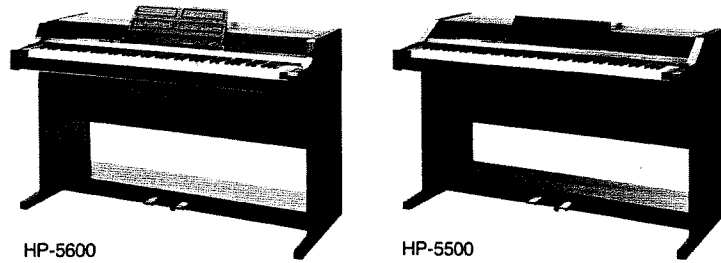

1

- Fit the rocking arm **A** on each end of the woofer box into the groove of the rocking holder **B** on each side panel.
- Fix the side panels with 4 mounting screws.

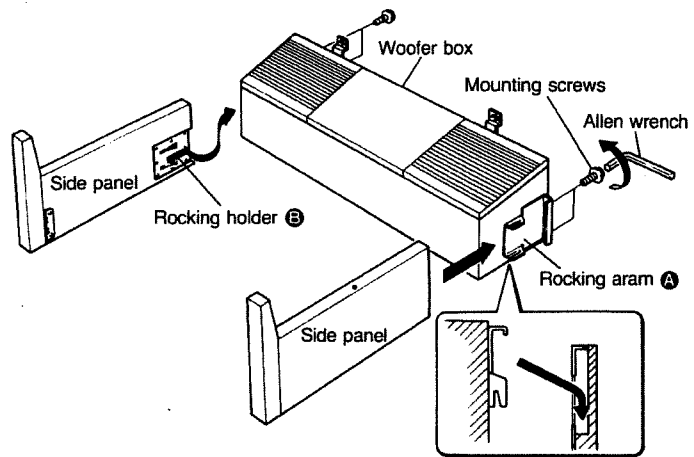

Accessories:

Mounting screws	8
Connecting pins	2
Allen wrench	1
Screwdriver	1

2

- Install the pedal unit **C** to both side panels as shown in the figure.
- Fix it with 4 mounting screws using the allen wrench.

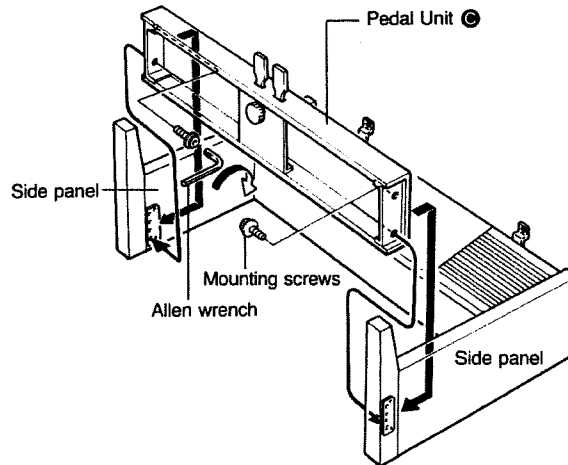

3

- Set the assembled stand upright.
- Link the connector of the Piano with the connector at the upper left of the stand (with the pawl facing to the boss on the connector housing).
- Place the body of the Piano on the stand using care not to have the connecting cords caught and then fix the body with connecting pins. (Use a large screwdriver or a coin to tighten the connecting pins.)

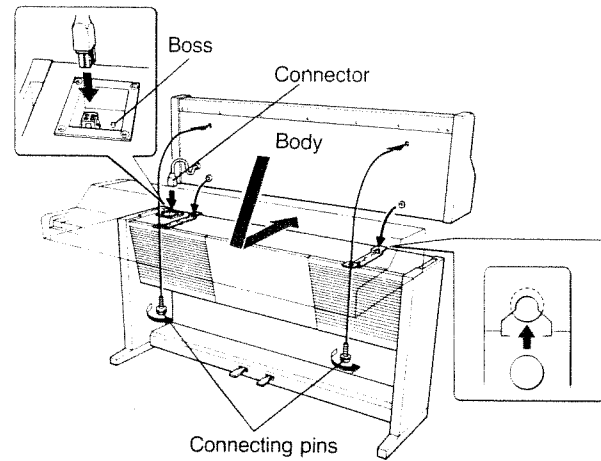
**4**

- Loosen the screw of the cord clamp **A** with the screwdriver supplied with the unit, put the power cord into the clamp and retighten the screw.
- Push the connecting cord into the cord clamps **B**.
- Connect the connecting cord to the jacks on the rear of the body.

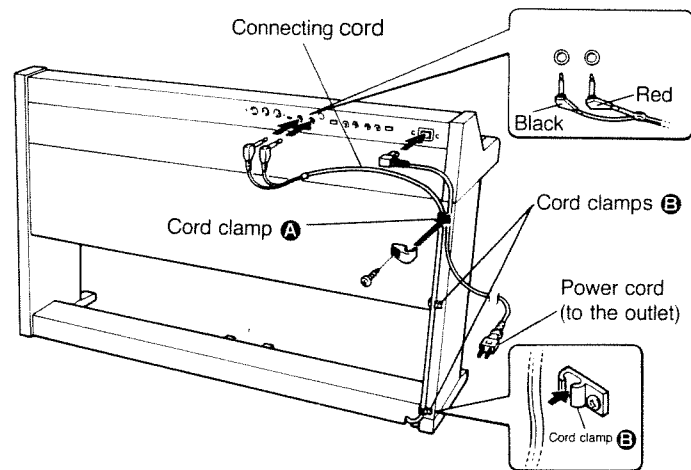
**5**

- After installing the assembled stand in place, turn the adjusting bolt to prevent deflection of the pedal unit.

CAUTION:

Whenever it is necessary to move the Piano, make sure to remove the body from the stand by reversing the assembly procedure and move them separately.

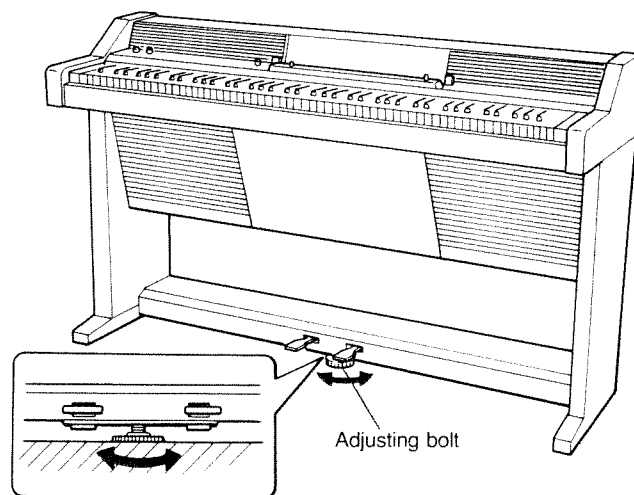

 Roland®

17049602

UPC 17049602



:098:

 Roland