

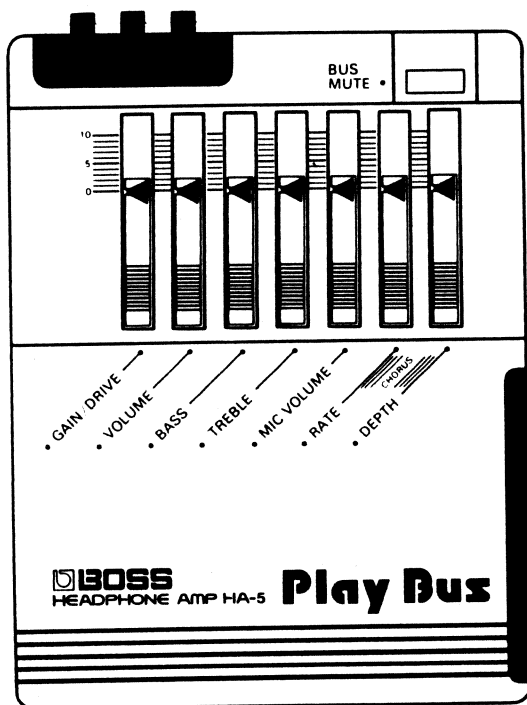

# BOSS

## HA-5 HEADPHONE AMP Play Bus

### INSTRUCTIONS



The HA-5 is a Stereo Headphone Amplifier with various attractive features.

- You can practice the guitar or keyboard by connecting the HA-5 to a Pocketable cassette player or Rhythm Machine and playing along with it.
  - Provided with the bi-directional BUS Line Jack, it is possible to connect the HA-5 to another HA-5 just by using a conventional audio cable with 1/4 phone plugs. Therefore, jam session is now easily practicable anywhere.
  - It is even possible to set up more than three sets of the HA-5's at a time.
  - Featuring various effects such as Overdrive, stereo Chorus (Which is equivalent to MODE-1 of the BOSS Chorus CE-3), stereo Short-delay and Tone Controls (TREBLE, BASS), the HA-5 offers extremely wide variation of sound creation. Moreover, Quick Response Noise Reduction circuit enables clear sound reproduction.
  - The MIC Jack can be used for both vocal and communication during the session.
  - While the MUTE Switch is depressed, you can mute the sound level of the instrument. This function is useful for the players' communication during the session.
  - The HA-5 can also be used as a monitor amplifier and pre-amplifier.
  - Hanging the HA-5 on your belt, you can act more freely and comfortably.
  - AC and Battery powered system is adopted.
- Please read these instructions carefully.

## Names and Functions

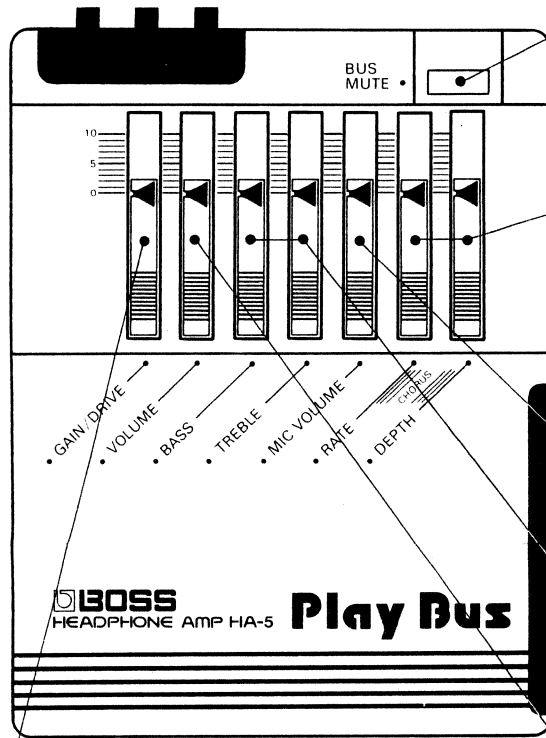

### GAIN/DRIVE Slider

When the NORMAL/OVERDRIVE Switch is set to the NORMAL position, this slider serves as an input level control, and when set to the OVERDRIVE position, serves as an Overdrive level control.

### At the NORMAL position

The GAIN/DRIVE Slider controls the input level of the instrument you use. Raising this slider increases the volume.

### At the OVERDRIVE position

As you raise the GAIN/DRIVE Slider, the Overdrive effect will become stronger.

### BUS MUTE Switch

This switch is used to reduce the Bus Line level. During the session, if any of the players depresses this switch, all sounds will be muted, so that the player is able to talk with other players.

### RATE, DEPTH Sliders

These sliders function only when the SHORT DELAY/CHORUS Switch is set to the CHORUS position.

**RATE:** Raising this slider quickens and deepens the Chorus effect.

**DEPTH:** Raising this slider deepens the Chorus effect.

\* When tuning, set the both sliders to zero.

\* When two sets of HA-5's are connected by their BUS Lines, using the Chorus effect may turn out effective.

### MIC VOLUME Slider

This is to control the microphone volume. Raising this slider increases the volume.  
\* If the microphone is not used, set this slider to zero.

### BASS, TREBLE Sliders

Raising the BASS Slider emphasizes Bass (low range response), and raising the TREBLE Slider emphasizes Treble (high range response).

### VOLUME Slider

This is to control the volume of the instrument you use. Raising the slider increases the volume.

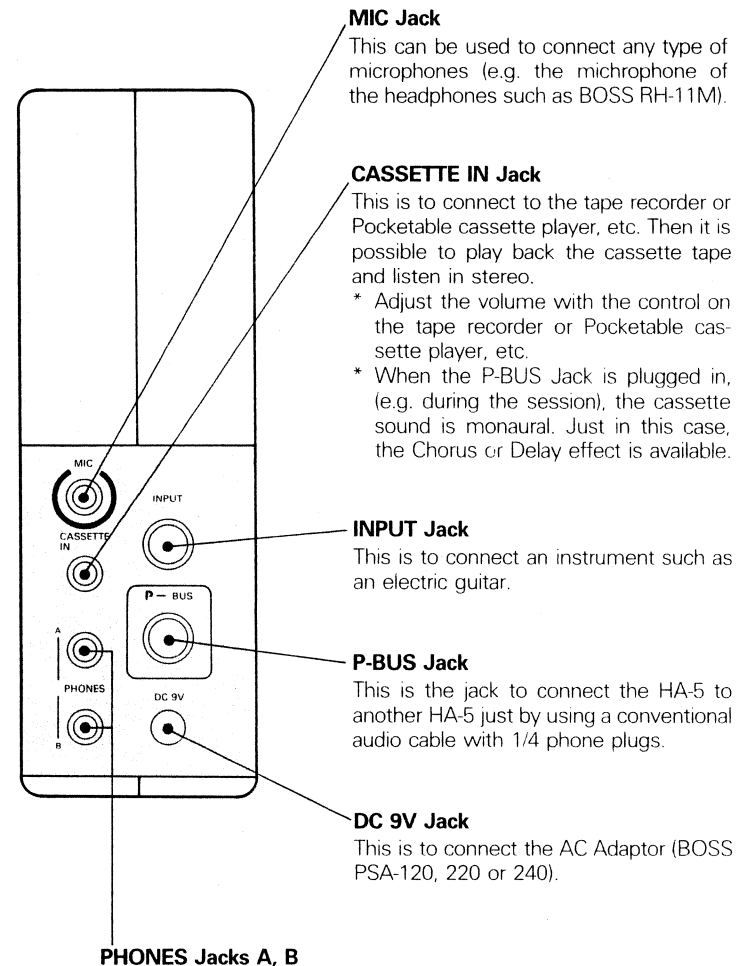

### MIC Jack

This can be used to connect any type of microphones (e.g. the microphone of the headphones such as BOSS RH-11M).

### CASSETTE IN Jack

This is to connect to the tape recorder or Pocketable cassette player, etc. Then it is possible to play back the cassette tape and listen in stereo.

\* Adjust the volume with the control on the tape recorder or Pocketable cassette player, etc.

\* When the P-BUS Jack is plugged in, (e.g. during the session), the cassette sound is monaural. Just in this case, the Chorus or Delay effect is available.

### INPUT Jack

This is to connect an instrument such as an electric guitar.

### P-BUS Jack

This is the jack to connect the HA-5 to another HA-5 just by using a conventional audio cable with 1/4 phone plugs.

### DC 9V Jack

This is to connect the AC Adaptor (BOSS PSA-120, 220 or 240).

### PHONES Jacks A, B

These are provided to connect Stereo Headphones. It is also possible to connect a tape recorder and record the performance. (Please be sure the connection cord is an appropriate one.) Moreover, these can be used to connect to a speaker (provided with power amplifier) or guitar amplifier to hear the sound.

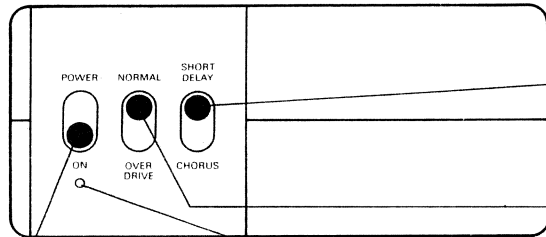

**POWER Switch**

**POWER Indicator**

This indicator lights when the HA-5 is turned on. If this fails to light or becomes dimmer, the cells should be replaced.

**NORMAL/OVERDRIVE Switch**

This switch is used to select either Overdrive or direct sound. If you wish to obtain direct sound of the instrument, set this switch to NORMAL, and if Overdrive sound, set to OVERDRIVE.

\* The Overdrive effect or input level can be controlled with the GAIN/DRIVE Slider.

**CHORUS/SHORT-DELAY Switch**

**At CHORUS position**

The stereo Chorus effect (which is equivalent to the MODE I in the BOSS Chorus CE-3) is available. The rate and depth of the effect can be controlled with the RATE and DEPTH sliders.

**At SHORT-DELAY position**

The Short-delay effect is obtained. The signal from the P-BUS Jack does not take on the Chorus or Delay effect. Monitoring the effect sound, however, is possible. In other words, only the signal from the PHONES Jack takes on the Chorus or Delay effect.

## Connection

### [Types of The Jacks]

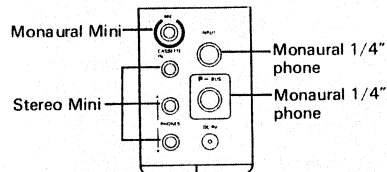

\* You may need an adaptor or phone to mini plug, etc. depending on what you are to set up to the HA-5. Please study each jack on the HA-5 and use a proper plug.

### [With the Headphone RH-11M]

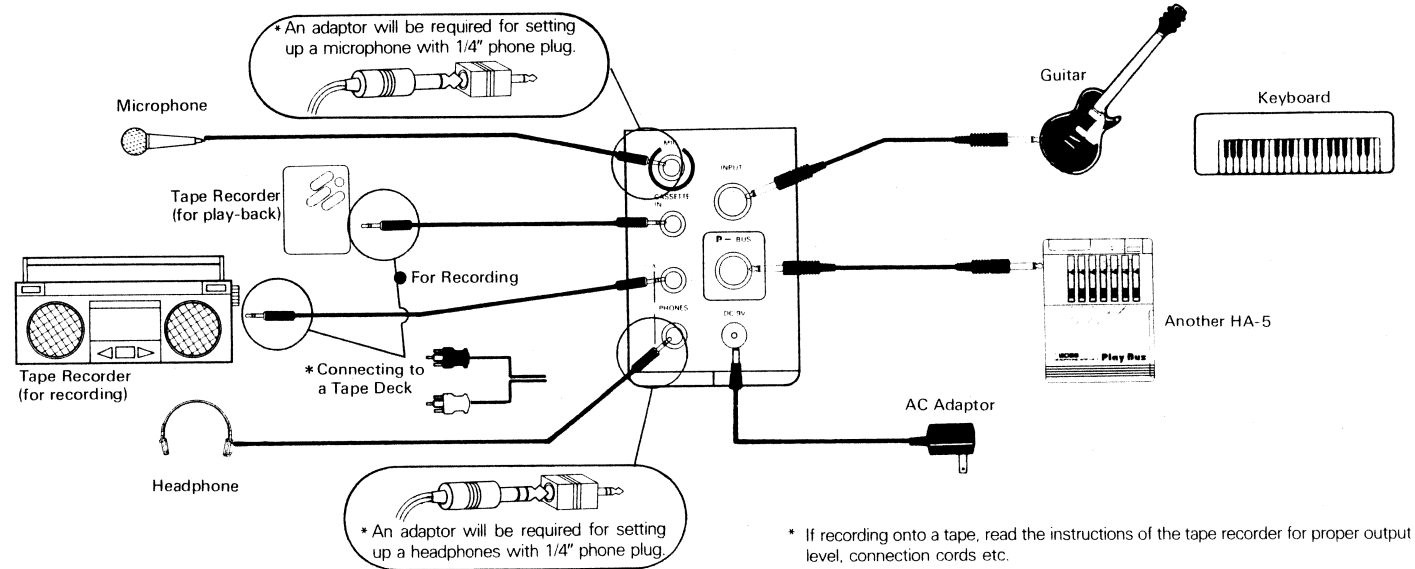
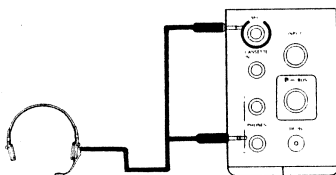

# Applied Connections

## Using 1 HA-5

- \* Using a minus-one music tape, you can practice the guitar, etc.

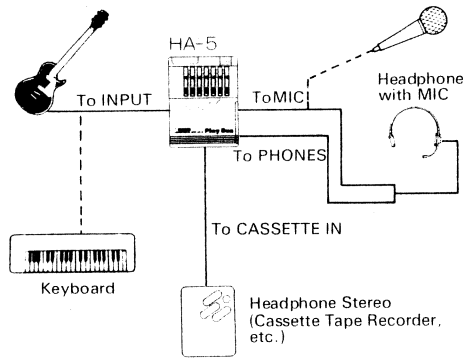

## Setting up with Amplifiers

- \* When the P-BUS Jack is plugged in, the Chorus or Delay effect is not obtained.
- \* If you wish to monitor in stereo, connect it to the PHONES Jack.
- \* Here, using the Chorus effect may turn out interesting.

## Using more than 2 HA-5's

- \* It is possible to hook up a tape recorder or rhythm machine etc. for the session.
- \* While the BUS Line is being used, the cassette sound turns out monaural.

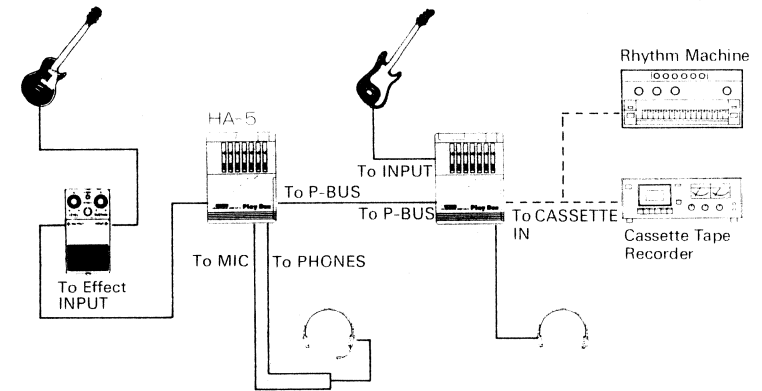

## <For Recording>

- \* Connecting the tape recorder to the PHONES Jack on the HA-5, you can record in stereo.
- \* For the set up, you need stereo mini cord (or stereo mini to stereo pin cord). For the details, refer to the instructions of the tape recorder you use.
- \* By connecting a tape recorder to the CASSETTE IN Jack, dubbing and other tape arranging is made possible.

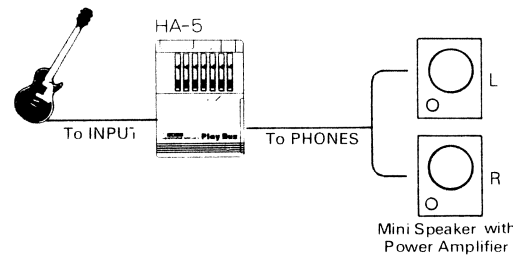
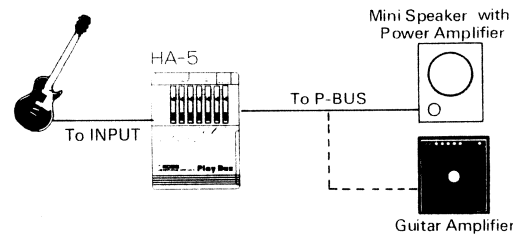
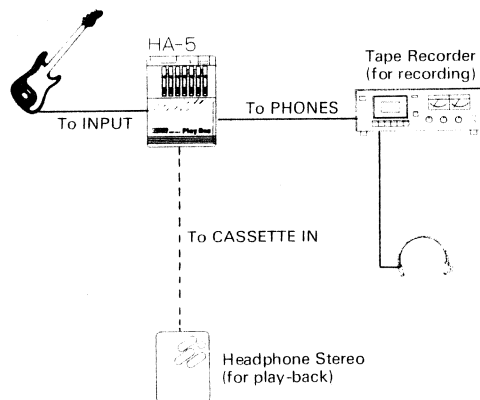

- \* There are many more other ways of using the HA-5, e.g. as a pre-amplifier, a monitor during live performance, a buffer amplifier, etc. Please enjoy the variations.

- \* If using more than two HA-5's at a time, use a multiple jack such as BOSS J-5 to split the BUS Line.

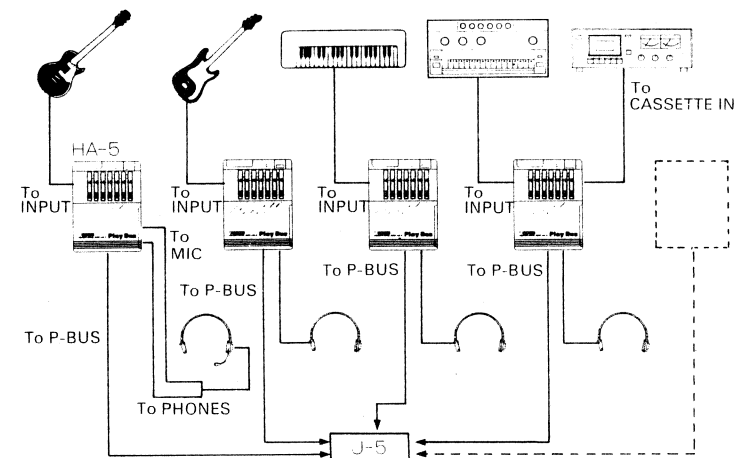

## Important

## Battery Replacment

## AC Adaptor

If the HA-5 is not to be used for a long period of time, please remove all the cells. If not, battery leakage may cause serious trouble.

If the battery voltage drops, the effect becomes inferior or no sound comes out. To prevent this, replace the cells. Please be sure to replace with a complete new set, and never leave the old cells. Also, please do not mix different kinds of cells.

Please avoid operating the HA-5 in extreme heat or humidity or where it may be affected by dust.

### Use six AA dry cells.

1. Remove the Battery Cover and replace the cells with a new set.  
\* Please make sure that polarities of the cells are correct.
2. Return the cover.

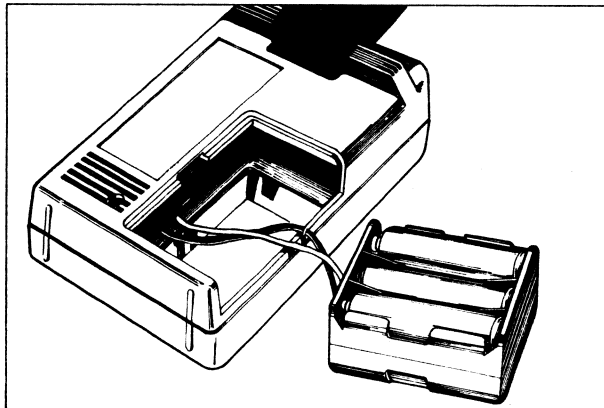

Please be sure to use the BOSS AC Adaptor PSA-120, 220 or 240 depending on the voltage system in your country. If you use the one other than these, the HA-5 may not function properly or even break down.

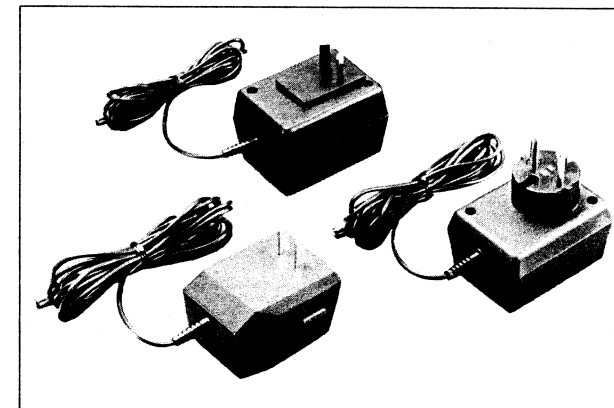

### Specifications

Power:	DC9V (AA Cell x 6) AC Adaptor (BOSS PSA-120, 220 or 240)
Consumption:	DC9V 30mA (at no signal) to 100mA (max.)
Controls:	GAIN/DRIVE, VOLUME, BASS, TREBLE, MIC VOLUME, RATE, DEPTH
Switches:	POWER, NORMAL/ OVERDRIVE, SHORT-DELAY/ CHORUS, BUS MUTE
Jacks:	MIC (Monaural, Mini) CASSETTE In (Stereo, Mini) PHONES A, B (Stereo, Mini) P- BUS (Monaural, 1/4" phone) INPUT (Monaural, 1/4" phone) DC9V In
Input Impedance:	Input 470 k $\Omega$ MIC 2.2 k $\Omega$ Cassette In 47 k $\Omega$
Input/Output Impedance:	P- BUS 10 k $\Omega$ Appropriate Headphone Impedance: 8 to 300 $\Omega$
Dimensions:	90(W) x 120(H) x 42(D)mm 3 1/2 x 4 11/16 x 1 9/16 in.
Weight :	350g/1.2oz. (including the batte- ries)
Accessory :	Belt Clip x 1

### Option

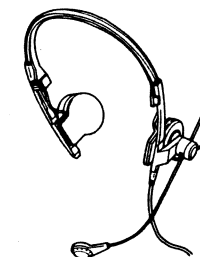

BOSS original Stereo  
Headphones with  
Microphone (provide  
with MIC ON/OFF  
Switch) RH-11M

\* Specifications are subject to change without notice.

 **BOSS**  
Products of Roland

 Roland®

---

10411

UPC 10411



12981

 **BOSS**