

Roland®

GUITAR SYNTHESIZER

GR-30

OWNER'S MANUAL

• Before using this unit, carefully read the sections entitled: "USING THE UNIT SAFELY" and "IMPORTANT NOTES" (p. 2; p. 6). These sections provide important information concerning the proper operation of the unit. Additionally, in order to feel assured that you have gained a good grasp of every feature provided by your new unit, this manual should be read in its entirety. The manual should be saved and kept on hand as a convenient reference.

About the Symbols in This Text

To explain clearly and concisely the operation of this equipment, the following notation is used in this manual.

- Text enclosed in square brackets ("[]") indicates buttons on the top panel. For example, [EDIT/PLAY] signifies the EDIT/PLAY button.
- The notation (p. 00) refers to a reference page.
- Explanations preceded by "*" are cautions.
- Explanations preceded by "▶" are informational notices.

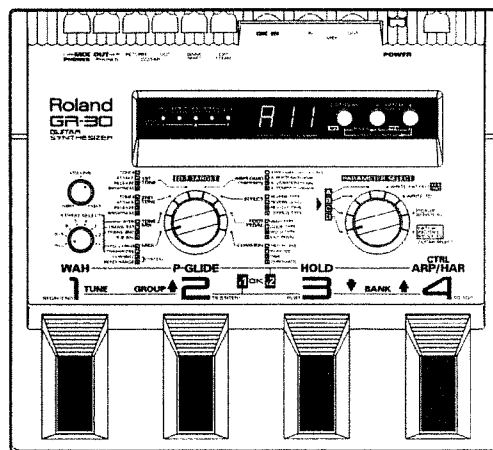

Copyright © 1996 ROLAND CORPORATION

All rights reserved. No part of this publication may be reproduced in any form without the written permission of ROLAND CORPORATION.

Starting
Out

Producing
Sounds

Selecting
Sounds

Pedals

Basic
Modes

Adjusting
Sounds

Built-In
Effects

Pedal
Effects

Arpeggiator

Synth
Harmonist

MIDI



Other
Functions

Appendices
(Index, etc.)







USING THE UNIT SAFELY

INSTRUCTIONS FOR THE PREVENTION OF FIRE, ELECTRIC SHOCK, OR INJURY TO PERSONS

About WARNING and CAUTION Notices







 WARNING	Used for instructions intended to alert the user to the risk of death or severe injury should the unit be used improperly.
 CAUTION	Used for instructions intended to alert the user to the risk of injury or material damage should the unit be used improperly. * Material damage refers to damage or other adverse effects caused with respect to the home and all its furnishings, as well to domestic animals or pets.

About the Symbols





	The  symbol alerts the user to important instructions or warnings. The specific meaning of the symbol is determined by the design contained within the triangle. In the case of the symbol at left, it is used for general cautions, warnings, or alerts to danger.
	The  symbol alerts the user to items that must never be carried out (are forbidden). The specific thing that must not be done is indicated by the design contained within the circle. In the case of the symbol at left, it means that the unit must never be disassembled.
	The  symbol alerts the user to things that must be carried out. The specific thing that must be done is indicated by the design contained within the circle. In the case of the symbol at left, it means that the power-cord plug must be unplugged from the outlet.

ALWAYS OBSERVE THE FOLLOWING

WARNING

- Before using this unit, make sure to read the instructions below, and the Owner's Manual. 
- Do not open (or modify in any way) the unit or its AC adaptor. 
- Do not attempt to repair the unit, or replace parts within it (except when this manual provides specific instructions directing you to do so). Refer all servicing to your dealer, or qualified Roland service personnel. 
- Never use or store the unit in places that are: 
 - Subject to temperature extremes (e.g., direct sunlight in an enclosed vehicle, near a heating duct, on top of heat-generating equipment); or are
 - Damp (e.g., baths, washrooms, on wet floors); or are
 - Humid; or are
 - Dusty; or are
 - Subject to high levels of vibration.
- Make sure you always have the unit placed so it is level and sure to remain stable. Never place it on stands that could wobble, or on inclined surfaces. 
- Be sure to use only the AC adaptor supplied with the unit. Also, make sure the line voltage at the installation matches the input voltage specified on the AC adaptor's body. Other AC adaptors may use a different polarity, or be designed for a different voltage, so their use could result in damage, malfunction, or electric shock. 

WARNING

- Avoid damaging the power cord. Do not bend it excessively, step on it, place heavy objects on it, etc. A damaged cord can easily become a shock or fire hazard. Never use a power cord after it has been damaged. 
- This unit, either alone or in combination with an amplifier and headphones or speakers, may be capable of producing sound levels that could cause permanent hearing loss. Do not operate for a long period of time at a high volume level, or at a level that is uncomfortable. If you experience any hearing loss or ringing in the ears, you should immediately stop using the unit, and consult an audiologist. 
- Do not allow any objects (e.g., flammable material, coins, pins); or liquids of any kind (water, soft drinks, etc.) to penetrate the unit. 
- Immediately turn the power off, remove the AC adaptor from the outlet, and request servicing by your dealer or qualified Roland service personnel when: 
 - The AC adaptor or the power-supply cord has been damaged; or
 - Objects have fallen into, or liquid has been spilled onto the unit; or
- The unit has been exposed to rain (or otherwise has become wet); or
 - The unit does not appear to operate normally or exhibits a marked change in performance.

⚠ WARNING

- In households with small children, an adult should provide supervision until the child is capable of following all the rules essential for the safe operation of the unit. ⚠
- Protect the unit from strong impact. (Do not drop it!) ⚠
- Do not force the unit's power-supply cord to share an outlet with an unreasonable number of other devices. Be especially careful when using extension cords—the total power used by all devices you have connected to the extension cord's outlet must never exceed the power rating (watts/amperes) for the extension cord. Excessive loads can cause the insulation on the cord to heat up and eventually melt through. ⚠
- Before using the unit in a foreign country, consult with your dealer, or qualified Roland service personnel. ⚠
- Since the GR-30's sound source is designed to achieve a wide range of tone changes, depending on the setting, sound levels may change greatly. Particularly when using the wah effect, or when adjusting certain tones, in order to prevent damage to your hearing, amps, speakers, and/or the like due to large or sudden changes in output, be careful not to set volume levels too high. ⚠

⚠ CAUTION

- The unit and the AC adaptor should be located so their location or position does not interfere with their proper ventilation. ⚠
- Whenever the unit is to remain unused for an extended period of time, disconnect the AC adaptor. ⚠
- Try to prevent cords and cables from becoming entangled. Also, all cords and cables should be placed so they are out of the reach of children. ⚠
- Never climb on top of, nor place heavy objects on the unit. ⚠
- Never handle the AC adaptor body, or its plugs, with wet hands when plugging into, or unplugging from, an outlet or this unit. ⚠
- Before moving the unit, disconnect the AC adaptor and all cords coming from external devices. ⚠
- Before cleaning the unit, turn off the power and unplug the AC adaptor from the outlet (p. 6). ⚠
- Whenever you suspect the possibility of lightning in your area, disconnect the AC adaptor from the outlet. ⚠

Contents

USING THE UNIT SAFELY	2
IMPORTANT NOTES	6

Starting Out

About the Guitar Synthesizer	7
What You Can Do with the GR-30.....	7
Panel Descriptions	8

Chapter 1: Producing Sounds

What You Need.....	11
Installing the GK-2A	11
Making Connections	12
Necessary Steps—From Powering Up to Performance	13
About the Play Mode.....	13
Setting Input Sensitivity	14
Guitar Tuning (Tuner Function).....	15
Matching Pitches of Other Instruments.....	15
Playing the Internal Synth Sounds with the Guitar...16	
What to do if there is No Sound When the Guitar is Played.....	16

Chapter 2: Selecting and Playing Sounds (Patches)

What is a Patch?	17
Rewritable Patches (User Patches).....	17
Read-Only Patches (Preset Patches).....	17
Selecting Patches: Four Methods	18
Using the Guitar (GK-2A) to Select Patches.....	18
Using the Base Module to Select Patches.....	18
Using the Base Module plus an External Footswitch to Select Patches	19
Selecting Patches with an External MIDI Foot Controller	20
Changing the Patch Order	21

Chapter 3: Controlling Functions and Effects with the Base Module Pedals

"Pedal Effect Mode": What It Is, and How to Call It Up.....	22
Getting the Same Effect While in Play Mode	22
Turning On/Off the Arpeggiator and Harmonist Functions.....	23
Changing Sounds with the Pedals.....	24
Getting a Pedal Wah Effect (Wah).....	24
Changing Pitch Dynamically (Pitch Glide)	24
Holding a Synth Tone After the String is Stopped (Hold).....	24
Calling Up the Tuner Function with a Pedal.....	25

Chapter 4: Three Basic Modes

Play Mode.....	26
Pedal Effect Mode.....	27
Edit Mode: What It Means, How It Works	28
Getting Into and Out of Each Mode	28

Chapter 5: Adjusting Sounds (Patches)

Details of Putting a Patch Together	29
Sound (Patch)—Composed of Two Tones	29
Recording and Settings of Each Patch.....	29
The Relationship Between Arpeggiator/ Harmonist and Patches	29
Saving Patches	30
Assigning Patches Before Saving (WRITE TO...).....	30
Cautions When Saving	30
Saving Patches From the GR-30 to Sequencers or Other MIDI Devices (Bulk Dump)	31

(1ST/2ND TONE)

Selecting and Creating Synth Sounds	32
Selecting Tones: The Raw Material (TONE #)	32
Increasing/Decreasing Attack Time (ATTACK).....	32
Changing Tone Release (RELEASE).....	33
Changing Tone Brightness (BRIGHTNESS).....	33

(TONE MIX)

Combining/Layering Two Sounds (Tones)	34
Determining Which Tones Will Be Sounded (LAYER)	34
Applying Detune (Subtle Pitch Shift).....	34
Transposing by Semitones (TRANS 1ST/2ND)	34
Choosing Different Settings for Different Strings (STRING SELECT)	35
Determining the Volume Balance of Two Tones (1:2 BAL)	35
What to do When a Tone is Supposed to Sound, but Doesn't	36

(COMMON)

Setting the Volume Level of Each Patch (PATCH LEVEL).....	36
Changing the Feel of a Performance (PLAY FEEL)	37
Following the Guitar Sound Shape (Envelope Follow).....	38
Increasing the Speed of Expression (Acceleration)	38
Changing Sound Placement (PAN)	39
Dividing Continuous Pitch Changes into Semitones (CHROMATIC)	40
When You Want to Make a Chord Resonate Beautifully.....	41
When You Want to Reproduce Piano-Like Pitch Changes.....	41

Chapter 6: Using the Built-in Effects

About the Effects Processors and Available Effects.....	42
Adjusting the Effects (EFFECT)	42
Selecting Reverb Type (REVERB TYPE).....	42
Selecting Reverb Levels and Times (REVERB LEVEL, REV/DLY TIME).....	43
Selecting Chorus Type (CHORUS TYPE).....	43
Temporarily Turning Off Effects (EFFECT BYPASS).....	44
What to do if Built-in Effects Cannot Be Heard.....	44

Chapter 7: Setting and Changing the Way Pedal Effects Work

(FOOT PEDAL)	
Selecting Wah Types (WAH TYPE)	45
Selecting Pitch Glide Type (GLIDE TYPE)	46
Selecting Hold Type (HOLD TYPE)	47
Using External Expression Pedals (EV-5 or Other).....	49

To Add Effects	49
To Switch Effects (EXP PEDAL).....	49

Chapter 8: The Arpeggiator Function

About Arpeggiator	51
"Arpeggio Patterns"	51
Arpeggiator Application Examples	52
Reproducing Arpeggios From Guitars and Other Instruments	52
Techno (Dance) Arpeggios	52
Reproducing Tremolo Effects.....	52
Other Ways to Use Arpeggiator.....	52
Effective Use of the Hold Function During Arpeggios	53
Changing the Sounding of Arpeggios.....	55
Turning Arpeggiator On and Off	55
Selecting Tones to Be Arpeggiated (ARPEGGIO SEL).....	55
Setting Tempo and Syncing Tempo to the External Device (A-TEMPO).....	56
Tap Tempo	57
Adjusting Sound Length (A-DURATION).....	57
Selecting Notes and Rhythm (A-RHYTHM).....	58
Copying Other Patch Arpeggio Patterns.....	59
Creating an Arpeggio Pattern	60
Programming One Note at a Time: The "Step" Method	60
The Feel of Tape Recording: The "Real Time" Method.....	61
Inputting with a Computer or Sequencer.....	62
What to do If You Have Difficulty Producing Patterns	63

Chapter 9: Adding Harmonies in a Specific Key (The Synth Harmonist)

About the Harmonist	64
What You Can Do with the Harmonist	65
Adding Synth Sounds to Guitar Sounds	65
Creating Harmonies with Two Synth Sounds.....	65
Operation	65
Turning the Harmonist On and Off	65
Selecting Harmony Tones (harmony SEL)	66
Setting Harmonic Intervals (h-style)	66
Setting Transpose and "h-style"	67
Setting the Key (h-key)	68
Changing the Key from External Pedal or Other Device with MIDI Note Messages (h-remote)	69
Switching Between Major and Minor During a Performance	69

Chapter 10: Connecting to External Sound Generators and Sequencers

About MIDI.....	70
(MIDI)	
Controlling an External MIDI Sound Device	70
Connecting to an External MIDI Sound Device	70
The Flow of a MIDI Messages, and Necessary Settings (CHANNEL, BEND RANGE).....	71
Transmitting in Mono Mode or Poly Mode	72

Changing Patch and Other Parameters by Transmitting MIDI Messages from the GR-30 (PG CHNG #).....	72
When You Want to Have Separate Sounds Programmed for Different Strings.....	73
Selection of More Than 128 Tones (MIDI BANK SELECT).....	73
How to Apply the Arpeggiator or Harmonist Using an External Sound Device	75
The Relationship Between Envelope Follow Function and MIDI Message.....	75
About Pedal Control for External MIDI Devices.....	75
Transposing Performance Data for an External Sound Generator (TRANPOSE).....	76
What to do if an External Module Doesn't Produce Sound as Expected	76
Using the GR-30 as an External Sequencer Input Tool.....	77
Connecting to a Sequencer.....	77
Input Procedures and Settings for Each Device	77
About "Local Control Off"	78
Creating Realistic Plucked String Instrument Sounds (Data)	78
How to Record Arpeggiator and Harmonist Performances	78
Reducing the Size of a MIDI Pitch Bend Message.....	79
Practical Use of MIDI Channels.....	80
What to do When You Have Difficulty Sequencing	80

Chapter 11: Other Convenient Functions

Restoring the Settings to Their Defaults (Initializing)	81
Recordering the Program Change Numbers from the Beginning	81
Using the GR-30 as an Expansion Sound Device for Keyboards or other MIDI Devices (Poly Mode Reception)	82
Using the GR-30 with a Number of Guitars (GUITAR SELECT)	82
Terminating Transmission of the MIDI Controller No. 7 (Volume).....	83
Terminating Transmission of the Bend Range Request Message	84

Chapter 12: Appendices

Troubleshooting	85
Specifications	89
Roland Exclusive Messages	90
MIDI Implementation	92
MIDI Implementation Chart.....	98
Parameter List (Blank Chart).....	99
Index (WORDS/PANEL PRINT)	100
Tone List.....	104
Information	106
Preset Patch List	108

IMPORTANT NOTES

In addition to the items listed under "USING THE UNIT SAFELY" on page 2, please read and observe the following:

Power Supply

- Do not use this unit on the same power circuit with any device that will generate line noise (such as an electric motor or variable lighting system).
- The AC adaptor will begin to generate heat after long hours of consecutive use. This is normal, and is not a cause for concern.
- Before connecting this unit to other devices, turn off the power to all units. This will help prevent malfunctions and/or damage to speakers or other devices.

Placement

- This device may interfere with radio and television reception. Do not use this device in the vicinity of such receivers.
- Do not expose the unit to direct sunlight, place it near devices that radiate heat, leave it inside an enclosed vehicle, or otherwise subject it to temperature extremes. Excessive heat can deform or discolor the unit.

Maintenance

- For everyday cleaning wipe the unit with a soft, dry cloth or one that has been slightly dampened with water. To remove stubborn dirt, use a cloth impregnated with a mild, non-abrasive detergent. Afterwards, be sure to wipe the unit thoroughly with a soft, dry cloth.
- Never use benzene, thinners, alcohol or solvents of any kind, to avoid the possibility of discoloration and/or deformation.

Repairs and Data

- Please be aware that all data contained in the unit's memory may be lost when the unit is sent for repairs. Important data should always be backed up in another MIDI device (e.g., a sequencer), or written down on paper (when possible). During repairs, due care is taken to avoid the loss of data. However, in certain cases (such as when circuitry related to memory itself is out of order), we regret that it may not be possible to restore the data, and Roland assumes no liability concerning such loss of data.

Memory Backup

- This unit contains a battery which powers the unit's memory circuits while the main power is off. When this battery becomes weak, the message shown below will appear in the display. Once you see this message, have the battery replaced with a fresh one as soon as possible to avoid the loss of all data in memory. To have the battery replaced, consult with your dealer, or qualified Roland service personnel.



Additional Precautions

- Please be aware that the contents of memory can be irretrievably lost as a result of a malfunction, or the improper operation of the unit. To protect yourself against the risk of losing important data, we recommend that you periodically save a backup copy of important data you have stored in the unit's memory in another MIDI device (e.g., a sequencer).
- Unfortunately, it may be impossible to restore the contents of data that was stored in the unit's memory and/or in another MIDI device (e.g., a sequencer) once it has been lost. Roland Corporation assumes no liability concerning such loss of data.
- Use a reasonable amount of care when using the unit's buttons, sliders, or other controls; and when using its jacks and connectors. Rough handling can lead to malfunctions.
- Never strike or apply strong pressure to the display.
- When connecting / disconnecting all cables, grasp the connector itself—never pull on the cable. This way you will avoid causing shorts, or damage to the cable's internal elements.
- To avoid disturbing your neighbors, try to keep the unit's volume at reasonable levels. You may prefer to use headphones, so you do not need to be concerned about those around you (especially when it is late at night).
- When you need to transport the unit, package it in the box (including padding) that it came in, if possible. Otherwise, you will need to use equivalent packaging materials.

Starting Out

About the Guitar Synthesizer

The GR-30 guitar synthesizer, though small and compact, is big on functions and high-quality sounds.

Say “synthesizer,” and people generally think of the typical kind with a keyboard controller. However, since the keys on a keyboard synthesizer are in essence simply advanced versions of basic on/off switches, synthesizers cannot really offer a faithful expression of strings or wind instruments.

On the other hand, with the guitar, the part of the instrument that actually vibrates (i.e. the string) is touched directly. As a result it excels in the expressive power that arises from slight changes in pitch — changes even smaller than a semitone — or vibrato or muting. And because guitars are easy to play, there are more people playing guitars than keyboards.

With these points in mind, the guitar synthesizer was developed as an instrument that, while played like a guitar, could be used for sound generation much like other synthesizers.

The guitar synthesizer is set up with separate pickups for each of the guitar’s metal strings. These pickups register and send the frequency and amplitude information in each string’s vibration to the synthesizer, which then in turn expresses the data as pitch, volume, and tone.

By connecting an external MIDI device (e.g. another sound generator) via the MIDI OUT connector, you can also export guitar performance data while simultaneously playing the instrument’s internal sound generator.

What You Can Do with the GR-30

- While playing with the feel of an ordinary guitar, you can freely choose from a huge selection of synthesizer sounds, 384 in all.
 - You can take solos with synth sounds only, or with layered synth and guitar sounds; you can even switch between the two modes.
 - When playing chords, you can get the rich, full ensemble sounds that the synthesizer provides.
 - Switch from electronic guitar to other instrument sounds (acoustic guitar, bass, organ, winds, ethnic instruments, and so on) in an instant — without actually switching instruments.
- Properly installed, the GK-2A synthesizer driver (sold separately) can also be used with an acoustic guitar strung with metal strings.
- Not only are you able to layer two synthesizer tones, and freely assign sounds to each string, you can also record fine adjustments to such parameters as brightness and attack, and difference between the pitch of the guitar and synthesizer sounds (p. 32—36).
- With the Synth Harmonist function, you can add beautiful synthesizer harmonies, in keys you designate, to guitar sounds (or to another synth sound — p. 64).
- You can get various arpeggio effects with the built-in Arpeggiator (p. 51).
- By applying effects (reverb and chorus) to the synthesizer sound, you can get richer, fuller sounds (p. 42).
- Get a variety of panning affects—put two different synth sounds in stereo (L-R), spread out the six guitar string sounds, distribute the sounds in order from left to right, and so on (p. 39).
- With the four tone switching pedals, you can get various effects such as wah-wah and whammy (p. 45—48).
- Using an external expression pedal (such as the model EV-5), you can change the volume, pitch, and arpeggio tempo, and so on for the sounds that are played (p. 49).
- You can also convert a guitar performance to MIDI messages for playing on an external sound generators (p. 70).
- When using for MIDI sequencer input, you can create realistic plucked stringed instrument parts (sounds), something that keyboards don’t do well, adding richer expression to melody parts (p. 77).
- Tuning is a snap when you set the guitar tuner function (p. 15).

Panel Descriptions

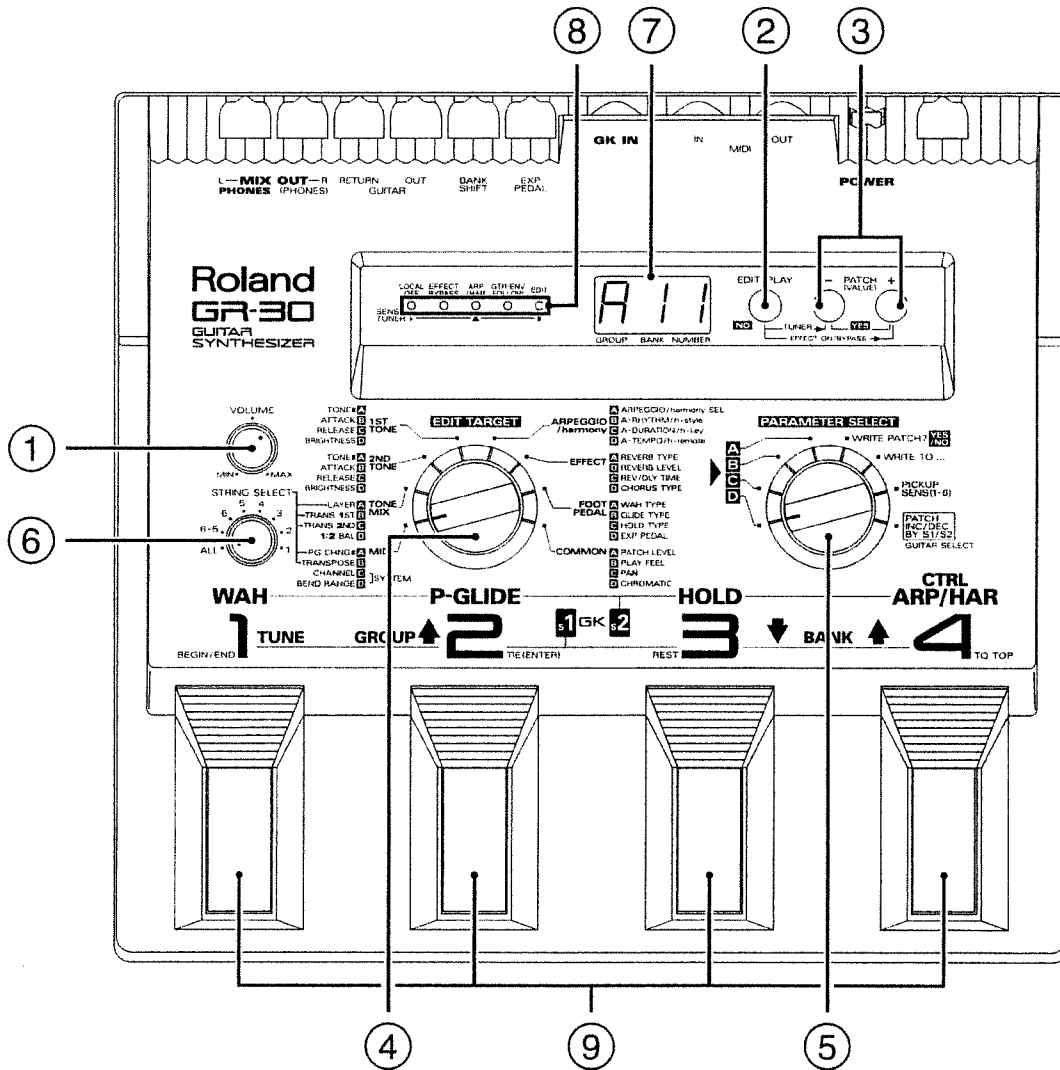

① VOLUME Knob

This knob adjusts the signal volume output from the MIX OUT jack. The center marking provides an easy reference setting when connecting to an instrument amp or mixer.

* The output level from the GUITAR OUT jack is controlled separately.

② EDIT/PLAY Button

This button switches between the Play mode and the Edit mode.

Pressing the button while you are in the Play mode switches the GR-30 to the Edit mode, enabling each dial to select various settings, and allowing you to create and save sounds, adjust sensitivity, and so on. Pressing the button again returns the unit to the Play mode.

③ PATCH (VALUE) Button [+] / [-]

In the Play mode (status at start-up), press these buttons to go through the different patches (tones) in sequence.

In the Edit mode, press the buttons to change the settings values or options selected with the dials.

➔ *Pressing the [+] button once increases the setting value by one. When the button is held down, the value continues to change. If you then hold down the [-] button at the same time, the speed of this change increases. Press the buttons in the reverse fashion to cause the values to decrease.*

The [+] and [-] buttons are also used in other tasks, including writing to patches (p. 30), setting the Effect Time Off (p. 44), calling up the Tuner (p. 15), and so on.

④ EDIT TARGET Dial

This dial is used for determining which of the eight "targets" (groups of settings) — 1ST TONE, TONE MIX, EFFECT, and the like — is to have settings acted upon. This dial has no effect other than in the Edit mode.

⑤ PARAMETER SELECT Dial

This dial is used for determining which of the groups [A] to [D] will have its settings acted upon. It is also used in other procedures such as adjusting pickup sensitivity (p. 14) and saving tones (p. 30).

This dial generally has no effect outside of Edit mode, but in the Play mode, only "PATCH INC/DEC BY S1/S2" can be selected when the dials turned completely clockwise. When it is in this position, you can go up and down through sequences of patch numbers just by using the "S1/S2" buttons on the guitar controller (GK-2A) (p. 18).

⑥ STRING SELECT Knob

When making changes in 1ST/2ND tone assignment (LAYER), transposition (TRANSPPOSE), and other settings of individual strings, use this knob to designate the which string is to be set.

⑦ Three-digit Indicator

In the Play mode (the mode at start-up), this three-place indicator displays the patch numbers.

In the Edit mode, it displays the values and settings status of the currently selected item. Various other messages are also displayed here.

⑧ Five-light Indicator

This illuminated indicator consists of five LEDs. For the Tuner function (p. 15) and sensitivity adjustment (p. 14), the entire group of indicator lights functions as a meter. In other cases, it displays the following status conditions:

LOCAL OFF

Starting up with local control off (p. 77) is indicated when the green light turns on.

EFFECT BYPASS

When, by pressing the [+] button while holding down [EDIT/PLAY], internal effects are temporarily switched off; this is indicated when the green light comes on.

ARP/HAR

The green light turns on when Arpeggiator is turned on, and the light shines red when Harmonist is turned on.

GTR-ENV FOLLOW

When settings to "PLAY FEEL" are made with either "EF1" or "EF2" (p. 37), the green light comes on, indicating that the decay of the string vibration is being accompanied by a corresponding change in the synth sound.

EDIT

The green light comes on when you go into the Edit mode. When a change to patch settings is made here, it is indicated by the light beginning to flash on and off. Furthermore, if you jump to the Play mode without performing the write procedure, the red light will flash, and if at this point you proceed to switch patches, a message is displayed stating that you have just lost the changes you had made.

⑨ Foot Pedals

These are four foot-operated switches. In the Play mode, together with the GK-2A's "S1," they are used mainly to switch patches. After pressing the GK-2A's "S2" to go into Pedal Effect mode, you can step on the switch to get performance effects such as wah, pitch glide, and hold. (Even in the Play mode, these effects are enabled when dial 5 is pointing at PATCH INC/DEC BY S1/S2.

Additionally, this can be used when calling up special functions to carry out operations such as creating Arpeggiator patterns (p. 60), sending BANK SELECT data to an external MIDI device (p. 73), initializing (p. 81), or transferring data.

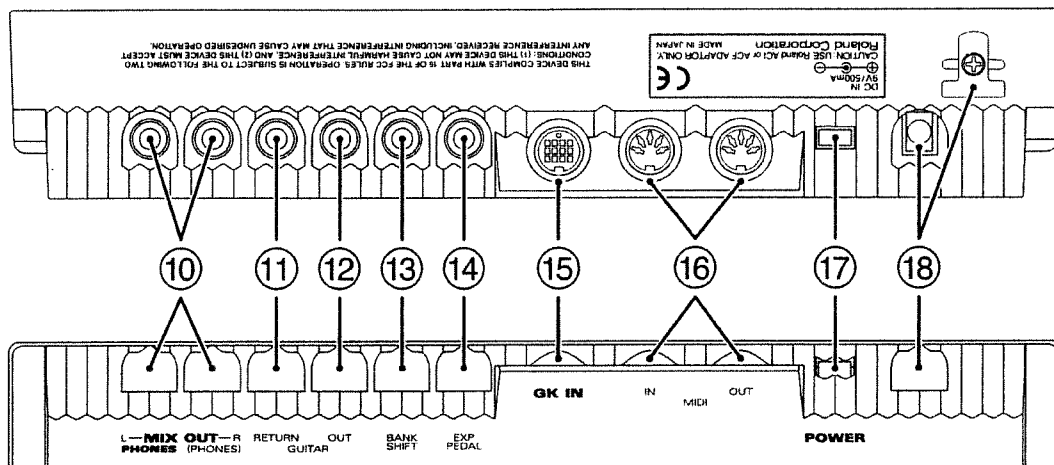

⑩ MIX OUT Jack
L-MIXOUT-R/PHONES (PHONES)

The output of the synthesizer is sent out here. Ordinarily, two cables are plugged into the L and R jacks, and the signal is then sent to a stereo amplifier (p. 12).

Furthermore, since both of the L and R jacks accept standard stereo plugs, they can also be used as two headphone jacks. (However, note that the left and right output of the R (PHONES) jack are reversed. Also be aware that you cannot simultaneously use one jack as a LINE OUT while using the other as a headphone jack.)

When there is nothing connected to the GUITAR OUT jack, the sound of the guitar itself is also mixed into, and sent out with this output.

** In order to have the sound of the factory-installed patches play correctly, use a stereo amplifier or stereo headphones if at all possible. If you must use monaural headphones, please be sure to turn the unit on while pressing Pedal 1 at the left of the base module. (p. 13)*

⑪ GUITAR RETURN Jack

When using the GUITAR OUT jack (the following item) as an external guitar effect send, use this jack for the return signal from the external effect (p. 13). With a single-input amp, although the synth and guitar sounds are combined, effect will be applied only to the guitar.

⑫ GUITAR OUT Jack

Use this jack when you wish the guitar output to be separate from the synth sound. Connect to your own guitar amp or guitar effects devices.

⑬ BANK SHIFT Jack

This jack is especially for connecting a patch bank expansion foot switch. You can connect two Boss FS-5U foot switches using a PCS-31 cable (each sold separately). Expansion foot switches control different functions in all modes except Play mode. (p. 26—28)

⑭ EXP PEDAL (Expression Pedal) Jack

An external pedal (e.g. model EV-5, sold separately) connected to this jack can be used to carry out a variety of controlling functions, including synth volume, tone, interval, Arpeggiator tempo, and so on. (p. 49)

⑮ GK IN Connector

Use this special 13-pin branch cable, included with the GR-30, to connect the GK-2A synthesizer driver (sold separately).

➔ *The original GK-2 can also be used in the same way.*

** For connection to a commercial guitar which supports a guitar synthesizer, consult the guitar's manufacturer or your dealer.*

⑯ MIDI Connectors (MIDI IN/OUT)

These connectors are for hooking up an external MIDI device with a MIDI cable. Use this connection when you want the base module to control the sounding of an external sound generator module, or to exchange tone data when using a MIDI device.

⑰ Power Switch

This is the main switch that turns power to the entire unit on and off.

⑱ AC Adaptor Jack/Cord Hook

The AC adaptor included with the GR-30 plugs in here. Additionally, hanging the adaptor cord on the cord hook can help prevent the cord from accidentally being pulled out of the jack while you are playing.

** Use ONLY the AC adaptor included with this guitar synthesizer. (This adaptor differs from those compatible with the GR-09.)*

Chapter 1: Producing Sounds

What You Need

The following items are necessary for getting sounds from your GR-30:

- GR-30 base module, with included accessories (AC adapter, 13-pin cable)
- Amplifier, speakers, and cables (stereo system wholly preferred); alternatively, stereo headphones
- GK-2A synthesizer driver
- Metal-stringed guitar with GK-2A properly installed

In addition to the above items, you should also have the following items on hand if needed:

- Guitar amplifier, guitar effects (when adding guitar sounds)
- Expression pedal (e.g. model EV-5: optional) (p. 49)
- External bank shift switches (two Boss FS-5U foot switches, one branch cable (stereo x 1 → mono x 2, 1/4" phone plugs): optional) (p. 19)
- MIDI foot controller (FC-200 or similar unit: optional) (p. 20, 69, 74)

○ Installing the GK-2A

Before all the other equipment is connected, the GK-2A must first be installed.

Following the procedure outlined in the GK-2A owner's manual, securely mount the driver in a position that won't hamper playing of the instrument. (Assembly instructions for use with the GR-09 may appear in the GK-2A owner's manual; however, with the GR-30, just use basic common sense in placement of the driver.)

To confirm the integrity of the GK-2A installation, please take special note of the following points:

- Make sure that the space between each string and its pickup is exactly 1 mm when you press the top fret. (Do not allow the string to come too close, either.)
- Do not allow the space between the guitar bridge and the GK-2A pickups exceed 20 mm.
- Be sure the placement of each of the pickups' six yokes (pole pieces) in relation to each string is correct.

For more detailed instructions, please refer to the GK-2A owner's manual.

<Guitars That Cannot Be Used with the GK-2A>

While the compact design of the GK-2A allows installation on many different guitars, please note the following types of guitars on which it cannot be used:

- a. 12-string, pedal steel, and other specially strung guitars; nylon-strung, gut-strung, and similar guitars; and bass guitars. (Even if installed on such instruments, the GK-2A will not function normally.)
- b. Guitars which, due to their structure, lack the space for proper mounting of the GK-2A.

Regarding situation "b." above, there are ways to complete the installation with a comparatively simple remodelling of the guitar. Please consult the dealer where you purchased your GK-2A.

➤ *Guitar manufacturers are currently releasing guitars for use as guitar synthesizers, not for use with the GK-2A, but to be connected directly with the GR series 13-pin cable. For more information, please ask your dealer or these guitar manufacturers.*

* *Take care when dealing with guitars having more than 25 frets, or with unusually high tunings, as the expression may be rather limited around the top fret.*

Making Connections

After setting up the guitar end of the system, connect your equipment following the examples shown in the connection diagram below.

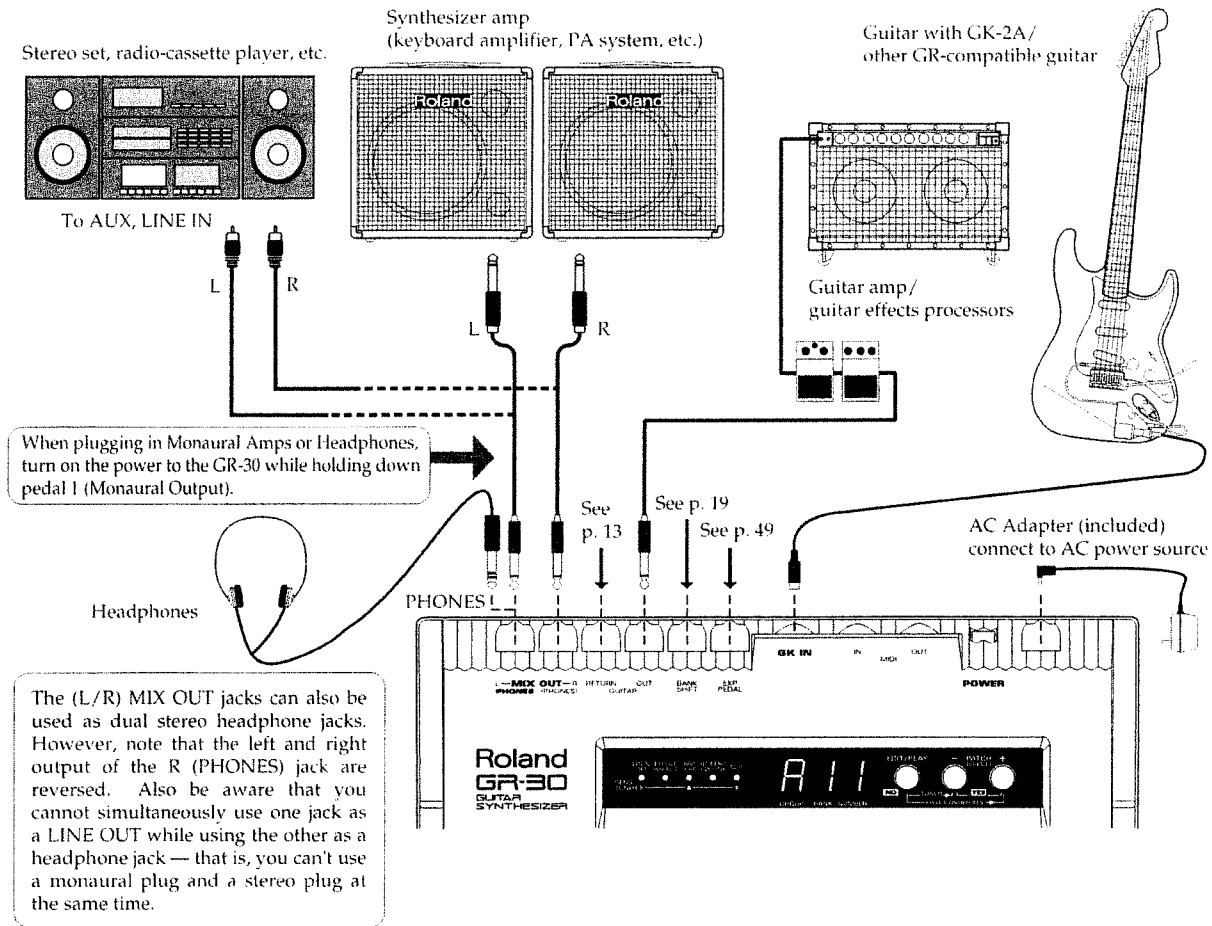

* To prevent malfunction and/or damage to speakers or other devices, always turn down the volume, and turn off the power on all devices before making any connections.

* To prevent the inadvertent disruption of power to your unit (should the plug be pulled out accidentally), and to avoid applying undue stress to the AC adaptor jack, anchor the power cord using the cord hook, as shown in the illustration.

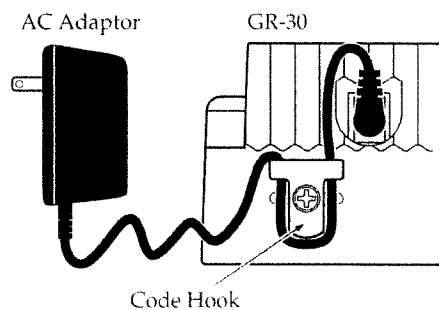

<IMPORTANT: STEREO OUT and the Selection of Amplifiers>

To get satisfactory performance from the GR-30's functions, and for the proper sounding of the preset Patches that came with the GR-30 when you purchased it, it is important to connect your setup to a stereo amplifier or speakers (or headphones). Please be sure to use stereo (two-channel) equipment.

➔ *If You Must Use a Monaural Amplifier...*

- When you turn on the power switch while holding down Pedal 1, "Mno" (Monaural) is displayed while the unit starts up. This temporary monaural output status remains in effect until the power is turned off.

- If you ordinarily use only a mono amplifier, please set the pan for each patch to "0" (p. 39). Additionally, when using the internal reverb as a delay, use "dL1" to "dL6" (delay) instead of "Pd1" to "Pd6" (panning delay) (p. 42).

➔ *The GR-30's sound generator is a PCM synthesizer which can reproduce a wide variety of tones. To better reproduce these rich synthesizer sounds, it is better to use a keyboard amp, other general instrument amplifier, PA system, or other such equipment, instead of using a guitar amplifier.*

- Ordinarily, the GUITAR OUT jack is used with a general purpose shielded cable in connecting external guitar effects or your own guitar amplifier. With this arrangement, you can control the sound of the guitar exactly in the same way as you would if the guitar were not connected to the GR-30.

- When there is no cable plugged into the GUITAR OUT jack, the guitar sound is output from MIX OUT, along with the synthesizer sound. This way, both guitar and synthesizer sounds can be played with just one amp. To add effects only to the guitar sound, connect in the following way:

GR-30 GUITAR OUT Jack → External Effect Input

External Effect Output → GR-30 GUITAR RETURN Jack

With this arrangement, if you use a guitar effects device (such as the Boss GT-5 or ME-8) simulating a guitar amp, you can achieve the most suitable sound quality for both the guitar and synthesizer sounds.

- The (L/R) MIX OUT jacks can also be used as dual stereo headphone jacks. However, note that the left and right output of the R (PHONES) jack are reversed. Also be aware that you cannot simultaneously use one jack as a LINE OUT while using the other as a headphone jack — that is, you can't use a monaural plug and a stereo plug at the same time.

Necessary Steps — From Powering Up to Performance

* After you have made all the connections properly (p. 12), please be absolutely sure to carry out the following steps when turning on the power. A mistake in the procedure can result in faulty operation, or may even cause damage to speakers or other components.

After you have finished checking connections, then, with the sound completely turned down, that is, with the GR-30's volume knob turned all the way counter-clockwise, press the power switch on the rear panel, to turn the unit on.

(Pressing the switch again turns the power off.)

➔ *If necessary, use the procedure shown on p. 81 to return the GR-30's settings to their original values before beginning.*

* *In order to protect the instrument's circuits. After turning the power on there is a wait of several seconds before operation can begin.*

About the Play Mode

After turning the GR-30 on, confirm that "A11" appears in the three-digit display window. (This number indicates the currently selected patch. Patches are units representing the tones that can be freely switched with a pedal, etc. during performance. → For details, see p. 29.)



← Currently selected Patch (A11)

<Play Mode>

When a patch number, like the "A11" that appears right after the power is turned on, is shown in the display, it indicates that you are in the Play mode. You will usually perform in this mode. Until you are familiar with how everything works, remember this: you can always return to the Play mode by turning the power off and then on again. (For more about how the dials and buttons work in the Play mode, please see p. 26.)

* While the patch number is showing in the display window, "Pd1" may appear once every several seconds. When this happens, just turn the PARAMETER SELECT dial to any position other than PATCH INC/DEC BY S1/S2. (The meaning of this message is explained later on p. 26.)

Setting Input Sensitivity

With the power turned on, adjust the input sensitivity of each string according to the way the GK-2A is mounted, as well as to match your own picking strength. Since these settings are recorded automatically, and will not be lost even if power is turned off, it is not necessary to reset the sensitivity each time you play.

<Procedure for Adjusting Input Sensitivity>

1. While in the Play mode, press [EDIT/PLAY].
2. Turn the PARAMETER SELECT dial to PICKUP SENS (1—6) — the sensitivity settings for strings 1 to 6.

The sensitivity setting function is called up, and the following appears in the display window:

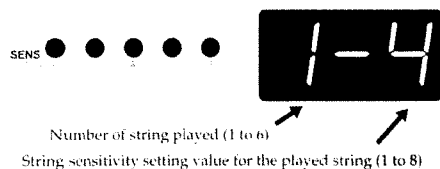

3. When string 6 of the guitar is played, the string number in the display automatically switches to "6".

The five-light indicator acts as a level meter, with the LEDs lighting in sequence from the left according to how strong the string is played.

4. If you find that, during your strongest actual playing, the indicator light furthest to the right turns a dim red, use the VALUE [+] and [-] buttons to adjust the sensitivity. If the indicator light shines bright red, it means that the level is set too high, so use the [-] button to lower the sensitivity.

* If the sensitivity is set too high, there may be dropouts in the sound, or you may be unable to express dynamics. Setting sensitivity too low may also result in abnormal operation, so take due care when making adjustments.

5. Adjust strings 5 to 1 in the same manner.
6. After you have finished the settings, press [EDIT/PLAY] to return to the Play mode.

<In any of the following situations, please be sure to readjust the sensitivity settings!>

- When using a guitar whose settings have not yet been made
- When you carry out the procedure to return the GR-30 to factory settings (p. 81)
- When you change the mounting of the GK-2A to accommodate a change in the guitar, such as when string height is readjusted
- When you replace a string with one of a different gauge

Depending on the particular guitar, in some rare cases the meter may still be pegged, even with the sensitivity at the lowest setting. If this kind of thing does occur, make more adjustments to slightly widen the space between the GK-2A's separate pickups and the strings.

When You Want to Change to Another Guitar Equipped with the GK-2A

- With the GR-30, you can make four different string sensitivity settings, which can be called up to match the guitar you are currently using. If you turn the PARAMETER SELECT dial, mentioned just after step 1 above, to GUITAR SELECT, "Gt1" will be displayed. (This is the factory setting). Use the [+] and [-] buttons to select from "Gt.1" to Gt.4", and for each one, starting with step 2, carry out the procedures described above to make sensitivity settings for four different guitars.
- As long as the power is on, the last settings to be selected are the ones that remain in effect. If you want to call up any of the other three settings groups, then while in the Play mode, press [EDIT/PLAY], turn the PARAMETER SELECT dial to GUITAR SELECT, use the [+] and [-] buttons to choose another guitar settings group from "Gt.1"- "Gt.4", and then press [EDIT/PLAY] again to return to the Play mode.

Guitar Tuning (Tuner Function)

To set the pitch accurately, try using the GR-30's built-in tuner to tune the guitar you are playing. This tuner works exactly the same way other tuners on the market do. With the power turned on, turn the PARAMETER SELECT dial to any position other than "PATCH INC/DEC BY S1/S2", and carry out the following steps.

<How to Tune the Guitar>

1. While pressing [S1] on the GK-2A, step on the pedal furthest to the left (TUNER). (You can also press [-] while holding down [EDIT/PLAY].)

The tuner function is called up, and the following appears in the display window:

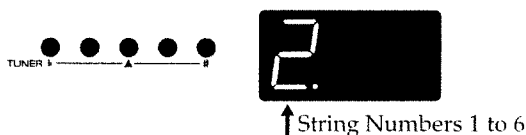

2. Play string 6 on the guitar.

The string number automatically switches to "6."

The note currently set for string 6 (notes are tuned by semitones) is shown in the second place of the display. ("D#" in the figure shown below.)

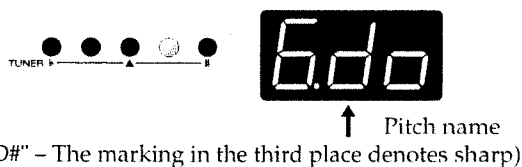

3. Turn the tuning peg while playing string 6 until the correct tuning is achieved.

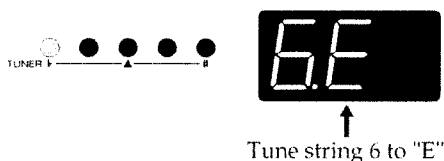

4. Along with using the tuning peg to make fine adjustments, the center green light of the five-light indicator also lights up when the tuning is close to correct.

When the light changes from green to red, it means the string 6 is now tuned to "E."



5. Tune each of the other strings, 5 to 1, to A, D, G, B, and E respectively.
6. When you are finished tuning, press any pedal, or [S1] or [S2] on the GK-2A, to return to the Play mode.

Matching Pitches of Other Instruments

The master tuning (basic pitch) set at the factory for the GR-30's sounds and internal tuner is A = 440.0 Hz. When you need to match the pitch of another instrument, or if you want to change the basic pitch, by carrying out the following steps, you change the master tuning.

1. While pressing [EDIT/PLAY], press the [-] button, and after the tuner function described above is called up, once more press the [-] button while pressing [EDIT/PLAY].
2. Middle A is shown in Hertz in the display.



3. Press the [+] and [-] buttons to set the pitch you want. (Here the pitch can be changed to any frequency from 427.2 to 452.7 Hz.)
4. Press [EDIT/PLAY] again to return to the Play mode.

* Except when "CHROMATIC" has been set to "on" (p. 40), changing the GR-30's master tuning does not produce a corresponding change in the pitch of the synthesizer's sound. Other than situations where you are controlling the sound with an external MIDI device, or when "CHROMATIC" in a patch is set to "on1" to "on3", synthesizer sounds controlled by the guitar have no connection with the master tuning, but rather, correspond to the guitar's actual pitch.

If you use the internal tuner to retune your guitar after making the settings outlined above, all of the pitches, including the guitar's, will in tune.

Playing the Internal Synth Sounds with the Guitar

After checking the connections to whatever amplifier you are using, and completing the sensitivity settings and tuning the guitar, try playing some sounds.

<How to Play the GR-30's Sounds with the Guitar>

1. Make sure that A11 is displayed. (p. 13)
2. Set the GK-2A's selector switch to SYNTH.
3. Turn SYNTH VOL on the GK-2A counterclockwise to raise the volume to a suitable level.
4. Set the VOLUME on the GR-30 to the center marking.
5. When you press pedal 3, the number in the display changes to "A13", and the patch (tone) is switched.

With these steps completed, you are now ready to play. Play your guitar while gradually turning up the volume on your amplifier, and you will hear the set tone, patch A13, from the GR-30's internal sound generator.

○ To Hear the Normal Guitar Sound...

Set the GK-2A's selector switch to MIX. If you then switch to GUITAR, the synthesizer sound generator will be muted, and only the sound of the guitar will remain.

○ To Change the Volume of the Synth sound generator...

Adjust the volume with either the SYNTH VOL knob on the GK-2A, or the GR-30's VOLUME knob.

➤ *Using the GR-30's VOLUME knob changes the total volume from the MIX OUT jacks. Thus, when the guitar sound is output from MIX OUT, both guitar and synthesizer sound levels are changed.*

(The guitar sound output of the GUITAR OUT jack is not affected. Guitar volume also unchanged when you use the GK-2A's SYNTH VOL knob.)

 **WARNING**

- Since the GR-30's sound generator is designed to achieve a wide range of tone changes, depending on the setting, sound levels may change greatly.  Particularly when using the wah effect, or when adjusting certain tones, in order to prevent damage to your hearing, amps, speakers, and the like due to large or sudden changes in output, be careful not to set volume levels too high.

What to do if there is No Sound When the Guitar is Played

First check the following:

- Check to see that amplifier and other equipment volume levels are correct, and confirm that all the equipment is properly connected. (p. 11)
- Make sure the volume on both the GR-30 and the GK-2A are up. Also make sure that the guitar/synth switch is not set to GUITAR.

When the Sound of a Specified Patch (Tones: p. 29) Fails to Play on All the Strings (or on a Particular String)

- If an expression pedal (p. 49) is connected, try pressing the pedal as far down as it will go.
- When using a monaural connection with your amp, be sure to turn the power on while pedal 1 is pressed.
- Confirm that the synth sounds for all of the strings have not been muted due to being switched to LAYER (p. 34).
- Even if the Arpeggiator is on, check to see if there is indeed any data in the arpeggio pattern (p. 55—63).

* *If the volume levels of the strings vary widely, please recheck the PICKUP SENS settings. (p. 14)*

Chapter 2: Selecting and Playing Sounds (Patches)

What Is a Patch?

“Patch” is the term for the GR-30’s tones that can be called up at any time with a foot switch or other device. There are 256 patches stored in the GR-30.

As an example, the “A11” that appears in the display when the power is switched on indicates that patch number A11 has been called up, and that the unit is ready to be played.

This machine’s basic unit of sound is the “tone.” These tones are a collection of useful sound wave forms such as “Synth Lead,” “Nylon Guitar,” “Organ,” and so on. A total of 384 different kinds of tones come built-in with the GR-30 (How to choose tones → p. 32; list of tones → p. 104).

In any patch, up to two selected tones are combined, and then various settings and adjustments, such as brightness, attack, difference between synthesizer and guitar pitch, and the like are made. The user has full freedom to make these settings and adjustments so that the patch may best suit the song to be played.

Another result of changing these settings is that you can write and store 128 patches (in the first half of the patch bank). (For more detailed information about patches, please refer to p. 29.)

Patch numbers are indicated by a three-digit code: a letter of the alphabet (A-H), followed by a numeral (1 to 8), and then another numeral (1 to 4). (Example: A83, D24, F61, etc.)



- Numerals 1 to 4 (Pedal Numbers)
- Numerals 1 to 8 (Banks)
- Letters A, b, C, d, E, F, G, H (Groups)

➔ *If for whatever reason it is necessary to do so, consecutive numerals 001 to 256 can also be substituted (p. 20).*

Rewritable Patches (User Patches)

**Patches in Groups A through d
(A11 to A84, b11 to b84, C11 to C84, and
d11 to d84)**

Here you can create patches to fit a song, or for other purposes, and then store those patches in memory.

(When you purchased your GR-30, the patches stored in these groups were the same as the following preset patches. If you want to reset the GR-30 patches to the original conditions, please carry out the initialization procedure explained on p. 81.)

Read-only Patches (Preset Patches)

**Patches in Groups E through H
(E11 to E84, F11 to F84, G11 to G84, and
H11 to H84)**

This is a collection of 128 preset patches, which have already been completely prepared by Roland. These patches are read-only, so although they can be changed, they cannot be written over with another patch. However, this also means no worries that they might be erased accidentally.

Preset patches are called up and used in the manner as user patches. Furthermore, they are convenient as references and basic material for the user wishing to create original patches.

Selecting Patches: Four Methods

Using the Guitar (GK-2A) to Select Patches

Sometimes (such as when you want to listen to all of the patches one after the other) you will want to select patches using only the guitar (GK-2A). In such cases, follow the steps below. (It is unnecessary to touch any pedal or anything else on the base module.)

1. In the Play mode, turn the PARAMETER SELECT dial to PATCH INC/DEC BY S1/S2. Now you can continuously switch patches with [S1] and [S2] on the GK-2A.

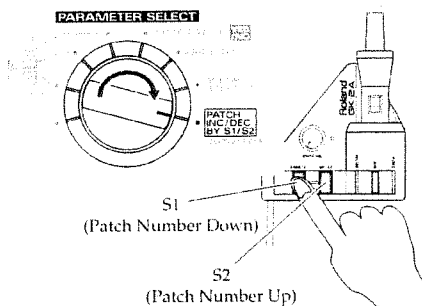

2. Pressing the GK-2A [UP/S2] once brings you to the next higher patch; by holding the switch down, you can switch continuously. Furthermore, when the other button (here the [DOWN/S1] button) is then also pressed, the switching occurs even faster. Pressing the [S1] and [S2] buttons in the reverse fashion will similarly return you to previous patches.

Now, using the GK-2A buttons to switch patches, try playing the guitar to listen to the patches in sequence.

<Using the Pedal>

With the GR-30 in the state just described, you can get various pedal effects (explained later). For example hold, pitch glide, and the like can be obtained, by stepping on the base unit's four pedals. (For details, see p. 24.) To indicate this status, when PATCH INC/DEC BY S1/S2 is selected, the "PdL" display appears (approximately once every four seconds), showing the patches and their corresponding numbers.

Additionally, with the unit in this same status, an external bank shift pedal can be used to change patch numbers, both up and down, just like the [+] and [-] buttons or the [S1] and [S2] buttons on the GK-2A.

* When PATCH INC/DEC BY S1/S2 is selected, with some patches, messages such as "C" may appear in the display approximately once every four seconds while the patch number is being displayed. This indicates the key of that patch when the Harmonist function is turned on.

Using the Base Module to Select Patches

- Selecting with the Foot (Pedal)

When playing live or in the studio, by using the pedal on the base module, you can instantly select one of four patches from the same group or bank.

<To Use the Pedal for Calling Up Patches from the Same Group or Bank>

1. In the Play mode, check to see if the PARAMETER SELECT dial is set to PATCH INC/DEC BY S1/S2; if so, turn the dial to another setting.
2. When you press pedals 1 to 4, you can instantly select a patch from the same bank of four patches in a group, with the number at the right in the display changing to show the number of the pedal currently pressed.

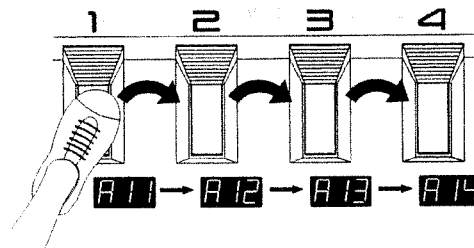

<To Use the Pedal for Calling Up Patches from a Different Group or Bank>

Used together with the GK-2A's [S1] button, you can use the pedal function to switch patches.

1. While in the Play mode, press either pedal 4 or pedal 3 while holding down the [S1] button on the GK-2A. As long as the [S1] button is held down, pedal 4 works as a [BANK ↑] (BANK UP), and pedal 3 as a [BANK ↓] (BANK DOWN). The display starts to flash, and when you step on pedal 3 or 4, numbers for the bank digit (the middle number in the display) go down or up.

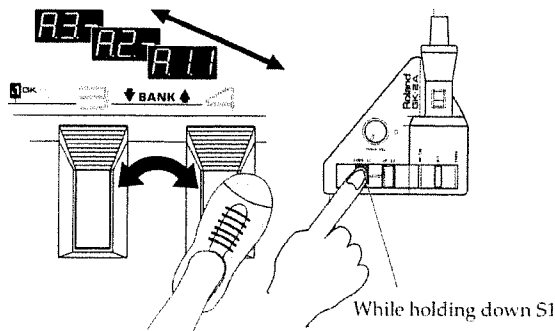

2. After selecting the desired bank, release the S1 switch, and you now will be able to select a patch from the four patches in that bank, using each of the four pedals.

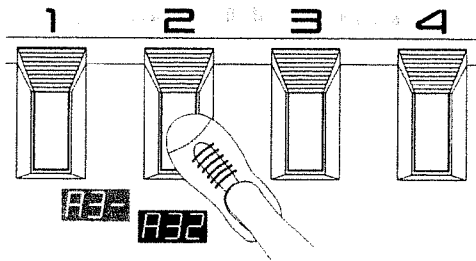

3. When you wish to change groups, step on [GROUP ↑] (pedal 2) while holding down [S1] as in step 1. Pedal 2 continues switching to the next group only while [S1] is being held; pressing the pedal allows you to progress to the next group.

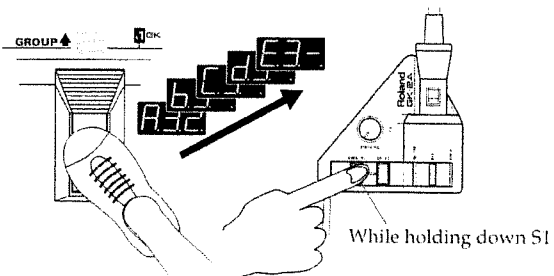

4. After selecting the desired group/bank, let go of the [S1] button as done in step 2, and you will now be able to designate patches by stepping on the pedals.

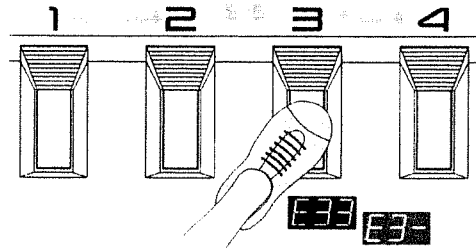

Using the Base Module plus an External Footswitch to Select Patches

By plugging a foot switch into the BANK SHIFT jack on the rear panel, you can switch banks (the preceding steps 1 and 2) without pressing [S1].

With one DP-5 (sold separately) to rise through patch bank numbers, or with two Boss FS-5U foot switches and a branch cable (sold separately) to move both up and down through the patch banks, it's possible to perform this procedure using only your feet.

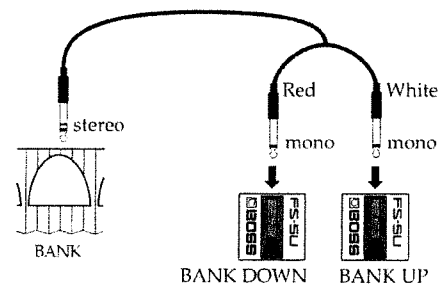

* Sometimes when pressing and releasing the foot switch to switch banks, you may find that while the bank does change, the patch number may not (light will flash); however, this does not indicate any malfunction. By pressing first the [+] button then the [-] button, you can return to the previous patch. You can also make the setting with the FS-5U polarity switch, as shown in the figure below.

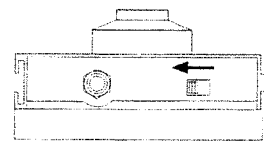

* If the PARAMETER SELECT dial has been set to "PATCH INC/DEC BY S1/S2", the action of the foot switch just described changes to switching patches up and down (the same as PATCH [+] and [-] on the unit).

Selecting Patches with an External MIDI Foot Controller

While the base module's four pedals are being used as designated pedals (p. 24) for such effects as hold and wah, you may also wish to switch patches using your foot.

In such cases, you should hook up an external MIDI foot controller (e.g. FC-200, Boss FC-50, and so on).

1. Connect equipment as shown in the figure below.

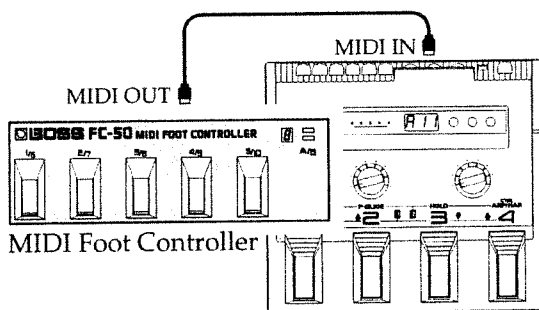

2. The patch number display corresponds to the display on the MIDI foot controller, but with numbers 1 to 256 instead of the alphanumeric symbols in patch numbers used by the GR-30.

With pedal 4 held down, when you turn on the power to the GR-30, "G.b.n." (Group/bank/number) appears in the display; press the [+] button to change to "dci" (decimal).

3. Press [EDIT/PLAY] to start up the GR-30. (The patch number displayed will be 001, rather than A11.)
4. Set the PARAMETER SELECT dial to PATCH INC/DEC BY S1/S2.
5. Set the MIDI send channel of the MIDI foot controller to match the channel of the GR-30 (p. 71; the factory setting is channel 11).
6. Use the MIDI foot controller to switch patches externally, operating the controller according to the instructions in the user's manual.

* The patch number using the numeral-only format that was set in step 2 is stored in memory even after the power is turned off. If necessary, return the patch number display to the Group/bank/number format. (Turn on the power while pressing down on pedal 4, press the [-] button in the "dci" display to return to G.b.n. format, then press [EDIT/PLAY] to engage.)

Additionally, user patches (001 to 128, or A11 to d84) can usually be selected when MIDI program change data is sent from the MIDI foot controller immediately after the power is turned on.

* MIDI program change numbers received by the GR-30 have a fixed one-to-one correspondence with the patches (001 to 128, or A11 to d84) they represent; this cannot be changed. (On the other hand, when patches are selected using the GR-30, you have the freedom to change and save the MIDI program change numbers that send the data to outside equipment. → p. 72)

Changing the Patch Order

When sequencing patches while performing a piece, or while you are on stage, if the patches are from the same group/bank (for example A11 to A14), you can switch patches very smoothly by using the pedals on the base module.

To change the order of the patches, before performing the patch write (p. 30) procedure you will use the "WRITE TO..." function (which specifies where the data will go). This designates the patch number (address) where the patch data from the present selection (or change) will be written.

<Changing the Patch Order>

Example: To change the contents of A21 and B62

First, to prevent the contents of patch A21 from being lost, clear a patch number that is not being used. (Since groups A through d of user patches are the same as groups E through H of preset patches, you may erase them without worry.)

After that, by writing B62 → A21, then temporary place-holder → B62, the order of A21 and B62 can be swapped.

1. Set the PARAMETER SELECT dial to "WRITE TO..."
2. After calling up patch A21, press the [EDIT/PLAY] button.
The proposed number to be written to is shown as "A.2.1.."
3. Pressing the [+] and [-] buttons, change the write address. Here, C.1.1 is indicated, so select C11 as the address.
4. After switching the PARAMETER SELECT dial to "WRITE PATCH?", press the [+] and [-] buttons simultaneously. "don." (done) appears in the display, the unit automatically returns to the Play mode, completing the writing procedure.
5. Using steps 1 to 4 above, write B62->A21 just as you did A21 → temporary place-holder (C11).
6. Complete the rearrangement by using the same process to write the temporary place-holder (C11) → B62.

** Since patch groups E through H are read-only, you cannot rearrange their order or create temporary place-holders with them. (However, you can copy them for reference or to use them as starting material when writing new patches.)*

Chapter 3: Controlling Functions and Effects with the Base Module Pedals

“Pedal Effect Mode”: What It Is, and How to Call It Up

By pressing the four pedals after changing modes, you can turn on and off the Arpeggiator (and Harmonist) function, and get effects like synth sound hold and wah pedal.

This status is called Pedal Effect mode, and along with the Play mode, is commonly used in performances.

<How to Switch to the Pedal Effect Mode>

1. Turn the PARAMETER SELECT dial to any position other than PATCH INC/DEC BY S1/S2.
2. Press [S2] on the GK-2A to change to Pedal Effect mode; this change will be indicated by “PdL” (Pedal) flashing in the display.

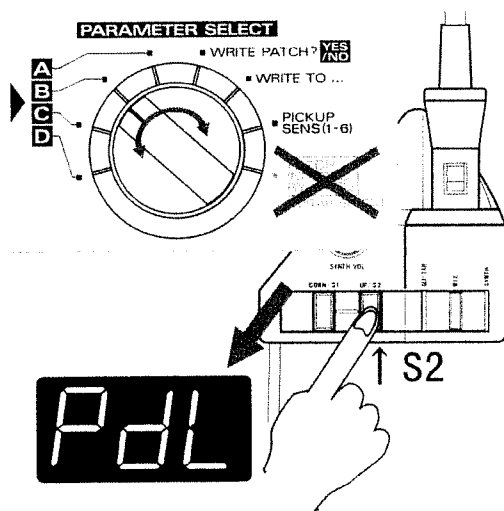

➔ Press either [S1] or [S2] on the GK-2A to return to the Play mode.

Even if the same pedal is pressed, the amount of effect will differ from patch to patch. These can be changed to suit a song, or for another particular purpose, and can be saved to the patch.

For more information about each function, and how to change the amount of effect, please see Chapter 7 (p. 45—48).

Getting the Same Effect While in Play Mode

Even in the Play mode, when you turn the PARAMETER SELECT dial to PATCH INC/DEC BY S1/S2 to allow selection of patches using the buttons on the GK-2A, the four pedals automatically function as they would in Pedal Effect mode. (Under these conditions, “PdL” will appear once during about four seconds, indicating that pedal effects are available.)

For more information about these procedures please refer to p. 18.

* With the exception of the arpeggio latch hold (p. 53) pressing more than one pedal the same time may result in abnormal action, so please exercise due caution.

Turning On/Off the Arpeggiator and Harmonist Functions

The GR-30 comes with Arpeggiator and Synth Harmonist (hereafter referred to as "Harmonist") functions, which can be turned on and off using the pedals.

(For details about both functions, see p.51 and p. 64.)

<Switching On and Off>

1. Switch to Pedal Effect mode (p. 22). Alternatively, set the PARAMETER SELECT dial to PATCH INC/DEC BY S1/S2.
2. Pressing pedal 4 (CTRL ARP/HAR) turns Arpeggiator (or Harmonist) on and off; the ARP/HAR at the center of the five-light indicator turns on and off as well.

The ARP/HAR indicator shows whether the function is on or off as follows:

Green Light OnArpeggiator On
Red Light OnHarmonist On
No Light.....Off

Make sure that the sound actually changes by turning on and off a factory preset patch while playing.

- ➔ *Arpeggiator (p. 51) is a function that automatically creates arpeggios (chords whose notes are played in sequence, rather than simultaneously) when a chord is played. The Harmonist function (p. 64) creates harmonies in designated keys using either guitar and synthesizer sounds, or two synthesizer sounds together.*

For each patch, either function may be selected. Even if a patch is turned off, since Arpeggiator and Harmonist are selected in the GR-30, when the patch is turned on, the color of the light on the ARP/HAR indicator shows which function is currently selected.

- ➔ *When you want to switch Arpeggiator in a certain patch to Harmonist (or vice versa), you'll change the ARPEGGIO/harmony SEL setting (p. 55, 66).*

<Some Notes About the Display>

When Arpeggiator is turned on, "ArP" appears in the three-digit display.

When Harmonist is turned on, "HAr" is shown. When the effect is turned off, "oFF" appears.

Furthermore, when turning these functions on and off, the red EDIT indicator light flashes, but as this is due to the On/Off data having been written directly to the patch with the pedal, you can ignore this light. (If at this point you write the patch (p. 30), the On/Off status at that particular moment will be saved to the patch.)

Additionally, if the Harmonist function is turned on in Pedal Effect mode, then while PdL is flashing, the key that has been set for that harmony (h-key) is shown in the display.

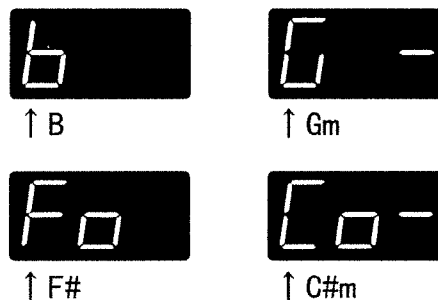

Even when in the Play mode if PATCH INC/DEC BY S1/S2 is selected (p. 18), when Harmonist is turned on, the key, as shown above, instead of "PdL", is displayed at intervals between patch numbers.

However, when the "h-style" "dim" (diminish) setting is selected, then "diM," and not the key, will be displayed.

Changing Sounds with the Pedals

In the Play mode, you can get different effects by pressing each of the pedals 1 to 4 in the follow way. Let's actually go into Pedal Effect mode by pressing the [S2] button on the GK-2A, and try these effects on various patches using the pedal. The particulars of each effect will vary with each patch you change to.

➤ *In the Play mode, even if the PARAMETER SELECT dial is set to PATCH INC/DEC BY S1/S2 when you press a pedal, you will still be able to get the same effects.*

Getting a Pedal Wah Effect (Wah)

You can get several of the most typical wah effects by pressing pedal 1 (WAH). Repeatedly pressing and releasing the pedal produces changes in the sound resembling those of a guitar wah-wah pedal, and these effects can then be added to synthesizer sounds. You can choose from a number of variations already prepared using different combinations of rate of sound change, degree of change, panning, how peculiar the sound is, and so on; these can then be saved to each patch.

Also, when you select modulation (shown in the display as "Mod") in the patch settings (p. 45), then instead of wah-type effects, you will hear a deep vibrato (undulating or wavering pitch) when the pedal is pressed. With this effect, since you can achieve the machine-type vibrato that so resembles that typically "synth-ish" sound as well as the more human-feeling swaying effect you get when using finger vibrato, you can decide which one to use. (For more information about these effects and how to use them, see p. 45.)

➤ *It may happen that if you press pedal 1 (WAH) once when other pedals are not being pressed, the sound is different than when the patch was selected. (The sound may be muffled, or have a strange quality to it.)*

Return to the original patch, switch to a different patch and then recall the original patch again. If the bank shift pedal is connected, then while in Pedal Effect mode, you can return to the original patch by pressing the bank down pedal.

The application of wah-type effects varies with the selected tone.

Changing Pitch Dynamically (Pitch Glide)

Press pedal 2 (P-GLIDE) to get a pitch glide effect. This effect creates continuous changes in pitch over variable time intervals, long or short.

With chords, since you can make big changes in pitch while maintaining each of the intervals of the chord, it differs from a guitar's vibrato arm/vibrato bar/whammy bar, and provides a unique effect.

As for the time duration and glide intervals, you can select from nine prepared pitch rise and fall patterns, and then save them to patches (p. 46).

* *Depending on the selected tone, the tone settings, and performance conditions, the width of the effect may be limited.*

Holding a Synth Tone After the String is Stopped (Hold)

Press pedal 3 (HOLD) to get the hold effect. When you use this effect, the synthesizer sound continues to play even after the guitar string has stopped vibrating.

You can choose from a number of variations to suit whatever you have in mind — hold the synthesizer chord while the guitar plays melody, hold only one of two layered tones, hold only strings 5 and 6, and more — and then save them to patches (p. 47).

* *While the Arpeggiator is on (the red light of the ARP/HAR five-light indicator will be on), the way Hold behaves and the variations that can be selected will be different than normal (p. 53).*

<Display Details>

When pedal 1 (WAH) is pressed

"UAH" or "Mod" appears in the display

When pedal 2 (P-GLIDE) is pressed

"P.GL" appears in the display

When pedal 3 (HOLD) is pressed

"HLd" appears in the display

Additionally, all the lights of the five-light indicator will flash to indicate a pedal effect is in operation.

Calling Up the Tuner Function with a Pedal

1. In the Play mode, set the PARAMETER SELECT dial to any position other than "PATCH INC/DEC BY S1/S2," then holding down [S1] on the GK-2A and press the pedal furthest to the left (TUNER).

The tuner function is called up, and the following appears in the display.

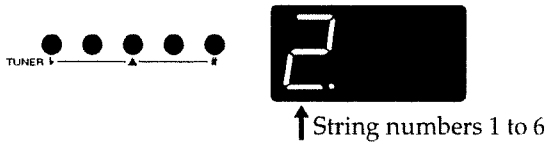

2. After you have finished tuning, following the instructions on p. 15, press any pedal, or press [S1] or [S2]. (This will return you to the Play mode.)

Chapter 4: Three Basic Modes

The three main modes of the GR-30 allow you to:

- select tones and perform (Play mode)
- get effects such as wah or hold using the pedal on the base module (Pedal Effect mode)
- create and modify patches, and write them into memory (Edit mode)

How buttons, dials, and knobs work will vary depending on which mode you are in.

Play Mode

In the Play mode, buttons and dials work as follows:

[+] and [-]

For going forward and back through patch sets.

[EDIT/PLAY]

Switches to the Edit mode (p. 28).

Dials

Basically has no function. (Please see the right column.)

Pedals 1 to 4

For switching patches.

GK-2A [S1]

While this is held down, pedal workings can be changed. (TUNE, GROUP ↑, BANK ↓, BANK ↑).

GK-2A [S2]

Switches to Pedal Effect mode.

External Bank Shift Pedal

Switches patch banks (does the same thing as BANK ↓ and BANK ↑).

<When PATCH INC/DEC BY S1/S2 is Selected>

In the Play mode, the EDIT TARGET, PARAMETER SELECT, and STRING SELECT dials do not function, except when the PARAMETER SELECT dial is set to the PATCH INC/DEC BY S1/S2 position. In this situation, you can use just the GK-2A's [S1] and [S2] buttons to go up and down through the patch numbers. Buttons and dials work as follows:

[+] and [-]

For going forward and back through patches (p. 9).

[EDIT/PLAY]

Switches to the Edit mode (p. 28).

Dials

Turning the PARAMETER SELECT dial returns you to normal Play mode.
No other functions.

Pedals 1 to 4

Do the same thing as in Pedal Effect mode (p. 22).

GK-2A [S1]

Advances through patches.

GK-2A [S2]

Goes back through patches.

External Bank Shift Pedal

Switches patch banks (does the same thing as [+] and [-]).

When you want to check something by listening to patches played in sequence, or want to toggle between a pedal effect such as hold and a patch, PATCH INC/DEC BY S1/S2 is convenient way to do so without having to switch modes. With PATCH INC/DEC BY S1/S2 selected, patch numbers are shown in the display, with "PdL" appearing about once every four seconds.

Similarly, while the patch number is being displayed, messages such as "C" may appear about once every four seconds. This indicates the key of the Harmonist function (p. 64) that is being used with that patch.

Pedal Effect Mode

In Pedal Effect mode, buttons and dials work as follows.

Additionally, you can change detail of the effects that are available by pressing pedals 1 to 4 in each patch. You can also change and rerecord effects settings in user patches (A11 to d84).

[+] and [-]

For going forward and back through patches (p. 9).

[EDIT/PLAY]

Switches to the Edit mode (p. 28).

PARAMETER SELECT

Basically has no function, except for when turned to PATCH INC/DEC BY S1/S2, in which case it switches to the Play mode.

EDIT TARGET

STRING SELECT

No function.

Pedal 1

WAH → Adds effects such as a wah pedal-like sound or mechanical-sounding vibrato.

Pedal 2

P-GLIDE → Adds pitch glide (an effect which creates wide but smooth changes in the pitch).

Pedal 3

HOLD → Adds an effect which has synthesizer sounds continue to play even after the guitar string has stopped vibrating.

Pedal 4

CTRL ARP/HAR → Turns Arpeggiator (p. 51) and Harmonist (p. 64) on and off. It is also used as an auxiliary pedal for holding arpeggios (p. 53).

GK-2A [S1] and [S2]

Press either of these to return to the Play mode.

External Bank Shift Pedal (Bank Up)

This is used for Arpeggiator's Tap Tempo (p. 57). Also used to toggle between major and minor in Harmonist (p. 69).

External Bank Shift Pedal (Bank Down)

Returns sounds that have been changed with the wah function back to the way they sounded when the patch was called up. (Returns to the original sound even after normal patch switching procedures.)

With a suitable patch called up, let's switch to Pedal Effect mode, and actually step on some pedals and try some of these effects.

Edit Mode: What It Means, How It Works

While in either Play mode or Pedal Effect mode, pressing the [EDIT/PLAY] button once puts you into the Edit mode, and the green EDIT light at the right end of the five-light indicator lights up.

This mode is mainly for carrying out such procedures as creating sounds and making settings to the different kinds of effects, and writing these to patches. It is also used for making settings that affect the entire system, such as sensitivity and MIDI settings.

[+] and [-]

Used for changing the values settings of whatever item has been currently selected with the dial.

[EDIT/PLAY]

To return to the Play mode.

EDIT TARGET

Used when selecting one of the eight settings groups.

PARAMETER SELECT

Besides being used to select from among the four items (A through D) in each Edit Target, it is used for calling up the write and sensitivity settings screens.

STRING SELECT

Used to select a string which is to have settings applied to it (however many that is).

Pedals 1 to 4

Used as auxiliary pedals in such operations as making any number of settings, and confirming effects.

GK-2A [S1] and [S2]

Used for changing the values settings same as [+] and [-].

External Bank Shift Pedal

Same as above

While in the Edit mode, a change in even one place in the settings of the patch that has been called up is indicated by the green EDIT light in the five-light indicator starting to flash. Furthermore, if you jump to the Play mode without performing the write procedure, the red light will flash, and if at this point you proceed to switch patches, a message is displayed stating that you have just lost the changes you had made.

Getting Into and Out of Each Mode

Moving into and out of the three main modes, as well as changing the various other screens is carried out as shown in the figure below.

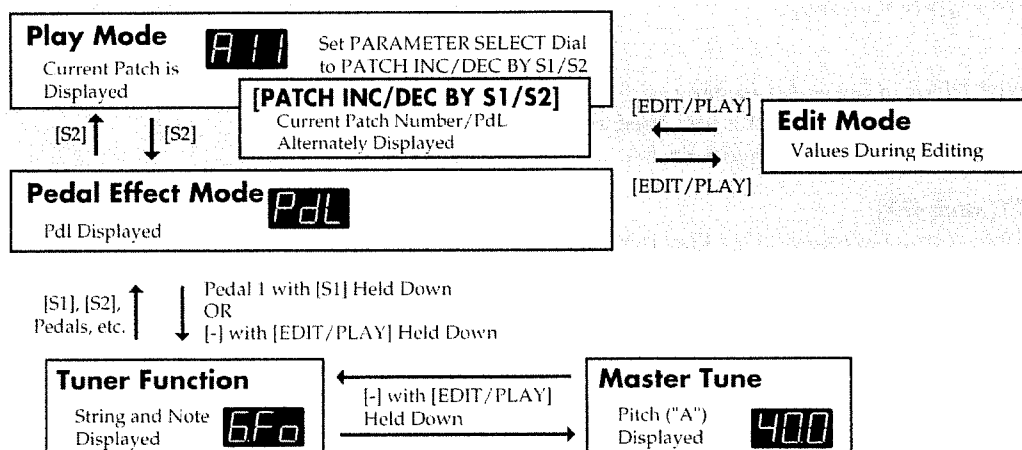

Chapter 5: Adjusting Sounds (Patches)

Details of Putting a Patch Together

Every patch is constructed as shown in the following figure.

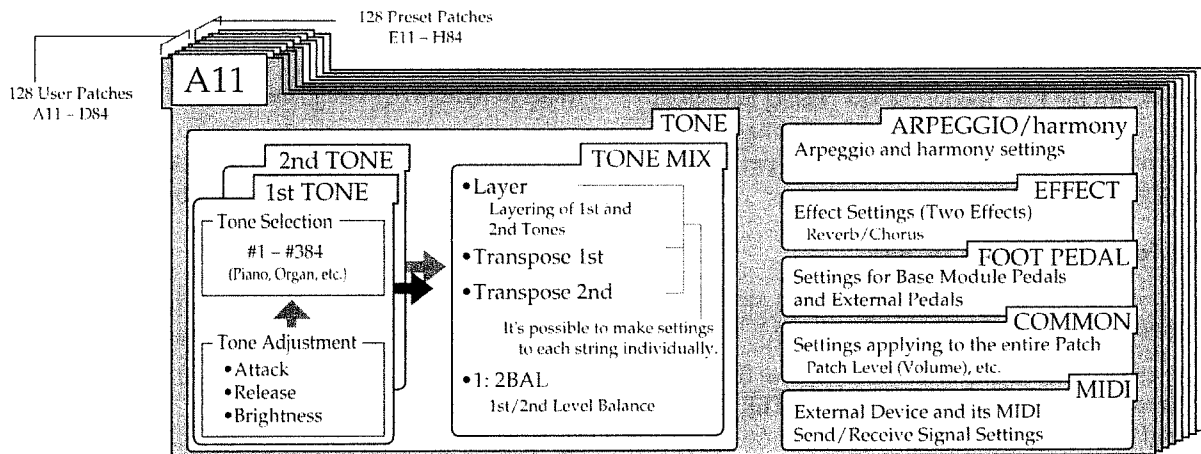

Sound (Patch) — Composed of Two Tones

As shown in the above figure, you can take any two of the 384 built-in tones (the base of material for synth sounds) and use them.

Those two selected tones are called the “first tone” and the “second tone.”

You can assign the selected tones separately to individual strings, and then layer them (p. 34).

You can also adjust parameters such as attack (p. 32), release (p. 33), brightness (p. 33), and transpose (p. 34).

Like selecting a tone, adjustments and settings can be saved to patches.

Recording and Settings of Each Patch

Besides patch tone selection and string assignments, and the adjustments, you can set and store the following items, as well as other items.

- How effects are applied (p. 42)
- Arpeggiator patterns and related settings (p. 51)
- Harmonist settings (p. 64)
- What happens when you step on a on-board or external pedal (p. 45)

- Program numbers sent to external MIDI devices (p. 72)
- External sound generator transpositions (p. 76)

For more information about these settings procedures, please consult the reference pages for each item.

The Relationship Between Arpeggiator/Harmonist and Patches

When you are playing, you can use either of the two functions, called Arpeggiator and Harmonist. Whether selecting one of them (p. 55, 66), or deciding whether or not to have the function on when a patch is called up (p. 55, 65), these settings can be made for each patch individually.

Likewise, arpeggio patterns (the sequence of strings that the Arpeggiator function creates and plays) can also be set to each patch individually. There are differing arpeggio patterns in each of the prepared patches that came with your GR-30 at the time you purchased it. You can also create and save your own original patterns. (For details, see p. 60.)

Saving Patches

Generally, when you use the dials to select settings parameters in the Edit mode, you can modify patches by using the [+] and [-] buttons to set values.

However, if at that point you switch to another patch, the effect of those changes or modifications will immediately end, and you will revert to previous conditions. (In the Play mode, the red [EDIT] light flashes to warn you of this.) To save any changes you have made, use the following steps to perform the PATCH WRITE procedure.

<Performing a Patch Write>

1. Press [EDIT/PLAY] to go into the Edit mode. (The green EDIT indicator light will turn on.)
2. Select each settings parameter. (Choose from positions A through D on the PARAMETER SELECT dial.)
3. Use the [+] and [-] buttons to modify or change settings. (The green EDIT indicator light now flashes.)
4. Turn the PARAMETER SELECT dial to "WRITE PATCH?", and each part of the patch number displayed, including periods, begins to flash.
5. After pressing the [+] and [-] buttons simultaneously to enter "YES," "don." (done) appears in the display.
6. The GR-30 will automatically return to the Play mode, completing the patch write procedure.

By following these steps, even if you switch to another patch or turn the power off, the changes you have made to the patch will be recalled when that patch is selected.

** If you write without designating a location where the patch is to be saved (explained next), you will overwrite the patch, and the contents of the patch before the changes were made will be lost.*

** As patch groups E through H are read-only, there are no such locations in which you can write, so you cannot write to these patches. (If you try to write a patch to E through H, a notice ("E-H") appears alerting you to the fact that the E through H groups of patches reside there, preventing you from carrying out the procedure.*

Assigning Patches Before Saving (WRITE TO...)

To save your changes to a patch with a number different than that of the original, use the following instructions to write while designating a save location.

1. After making changes to the patch settings, while staying in the Edit mode, turn the PARAMETER SELECT dial to "WRITE TO..."
2. Locations that may be written to are indicated by periods in the lower right corners of each of the three places of their displays (example: A.2.1.).
3. Press the [+] and [-] buttons until the patch number you want to write to is shown.
4. Turn the PARAMETER SELECT dial to "WRITE PATCH?."
5. After pressing the [+] and [-] buttons, "don." (done) appears in the display, and the GR-30 automatically revert to the Play mode.

Cautions When Saving

○ With Patch Write, the patch is written the way it actually sounds at the time you write it, and this includes whether the Arpeggiator or Harmonist functions are turned on or off. However, temporary tone changes made with the base module pedals, such as wah and pitch glide, or those from external expression pedals, will not be saved. This also applies to temporary switching off of internal effects (effect bypass function/ p. 44).

○ The following are items (system settings) that apply to the entire system by storing only one setting, making it unnecessary to write them to each patch. Changes made to these settings are saved automatically, and are stored even after the power is turned off.

- Setting sensitivity for each string (p. 14)
- Guitar Select (p. 82)
- Master Tune (p. 15)
- MIDI Send and Receive channels (p. 71)
- MIDI Pitch Bend Range (p. 71)
- MIDI Bank Select Send On/Off (p. 73)
- MIDI Pitch Bend Range Data Send On/Off (p. 84)
- MIDI Control Change Number 7 Send On/Off (p. 83)

Saving Patches From the GR-30 to Sequencers or Other MIDI Devices (Bulk Dump)

Settings of all user patches, and all system settings may be transferred in and out using MIDI. By using external equipment that can record MIDI data, you can also save patches externally. For this kind of operation, MIDI messages called "system exclusive messages," which can be interpreted only by those types of devices designated in that data, is used. For example, data either sent from the GR-30, read from a floppy disk, or entered by other means can be saved using a MIDI sequencer's real time recording or bulk librarian function. You can also send/receive data directly with another GR-30 by connecting the two together.

<Sending System Settings or Patch Data to an External MIDI Device>

1. Turn off the power to the GR-30.
2. Connect the GR-30's MIDI OUT to the MIDI IN connector on the external MIDI device.
3. While pressing (stepping on) pedal 3, turn the GR-30 back on. "ALL" will appear in the display.
4. Using the [+] and [-] buttons, switch to the following displays. Select the data you want to send from these.

ALL (Data)All user patches and system settings

SyS (System Setup) ..System settings

PA1 (Patch Data).....All user patches (128 patches)

A— (A Group)The 32 patches A11 to A84

b— (b Group)The 32 patches b11 to b84

C— (C Group)The 32 patches C11 to C84

d— (d Group)The 32 patches d11 to d84

A11 (Patch A11)Patch A11 only

A12 (Patch A12)Patch A12 only

⋮

d84 (Patch d84).....Patch d84 only

5. Put the external MIDI device in record mode. (Start the sequencer's real-time recording. The GR-30, even when receiving data, needs no special preparation.)
6. When you press [EDIT/PLAY], the data selected in step 4 is sent to the external equipment. While the information is being sent, the message "Snd." (Sending) flashes.

7. Sending is complete when the previous display returns. If the sequencer is on the receiving end of a transfer, stop recording at this point. After the GR-30 is finished sending, turn it off and then on again (restart) to resume normal operation.

<What about Receiving Previously Saved System and Patch Data?>

As long as it is turned on, the GR-30 can usually receive exclusive messages. Just by sending (or returning) the data via the GR-30's MIDI IN, the GR-30 can replay data sent to the accompanying external MIDI device anytime.

** Only when sending a single patch, one from A11 to d84 as described in step 4 above, back to the GR-30 is it necessary to carry out the patch write procedure (p. 30). (Since you designate an address to save to at the same time you write the patch, you won't need to copy to a patch with a number other than the original one already used as a temporary place-holder.)*

** Except for sending A11 through d84 (as single patches), no conditions apply for rewriting patch or system setting data at the receiving end when receiving exclusive messages with system or patch data. As data can otherwise be lost, exercise due caution. When necessary, back up your data from the GR-30.*

1ST/2ND TONE

Selecting and Creating Synth Sounds

You can select from the 384 sounds that are the basic material for patches, choosing a “1st tone” (first tone) and a “2nd tone” (second tone). Following the sequence below, let’s actually select some tones and assemble a patch tone.

➔ *When trying out the sequence to make a patch, please first call up the factory-installed patch A43, and use this as a base for the current task. Since this patch does not use any particularly complicated settings, it should be easy to hear any changes to the sound when you change each setting. (A version of the patch which is read-only but otherwise completely identical is located at E43. If the contents of A43 have been changed, please use E43 as your basis.)*

Selecting Tones: The Raw Material (TONE #)

First, let’s choose the first tone of the patch.

<Example of the Procedure>

1. Select patch A43, then press [EDIT/PLAY] to enter the Edit mode.
2. Set the EDIT TARGET dial to “1ST TONE.”
3. Set the PARAMETER SELECT dial to “A.” With this, you have selected the first tone’s tone number (TONE#). (In this example, “142” is indicated.)
4. Listening to the sounds as you go along, press the [+] and [-] buttons to go up and down through the tone numbers, and from those tone numbers 1 to 384, select a tone.

➔ *See the Tone List on p. 104.*

5. When you find a tone you want to use, switch the PARAMETER SELECT dial to WRITE PATCH. “A.4.3.” appears in the display.
6. Press both the [+] and [-] buttons simultaneously to write the patch. “don.” (done) appears in the display, and you are returned to the Play mode automatically. With this, the sound you selected is assigned to the first tone of patch A43.

➔ *When saving to another patch number, before step 5, turn the PARAMETER SELECT dial to “WRITE TO...”, and use the [+] and [-] buttons to designate a patch number as the destination.*

To select the second tone, at step 2, set the EDIT TARGET dial to 2ND TONE instead of 1ST TONE, and select the tone in the same manner as before.

Additionally, in the TONE MIX “LAYER” setting of patch A43, which we used in the example above, only the first tone has been set to play. When you go ahead and actually play the second tone, change to the LAYER setting using the procedure shown on p. 34.

Increasing/Decreasing Attack Time (ATTACK)

With the ATTACK setting, you can change the amount of time it takes for the first (and second) tones you selected with TONE# to rise to their highest volumes. Use this to control whether the tone starts with a gentle rise, or with a sharp attack.

<Example of the Procedure for Changing the Attack>

1. Select patch A43, which you used in selecting the first tone in the section on tone numbers (TONE#), then press [EDIT/PLAY] to enter Edit mode.
2. Set the EDIT TARGET dial to 1ST TONE, and the PARAMETER SELECT dial to “B” (ATTACK).
3. The current value, ranging from -50 to 50 (“0” in the example here), appears in the display.
4. Pressing [+] increases the value setting, and the volume of the sound rises more slowly. Press the [-] to decrease the value, changing the setting to produce a fast attack, like a percussion instrument’s.

➔ The width of the change you can make varies with the selected tone.

5. When you have set a sound you like, switch the PARAMETER SELECT dial to “WRITE PATCH?”, and press the [+] and [-] buttons simultaneously to write the patch.

➔ *When saving to another patch number, before step 5, turn the PARAMETER SELECT dial to “WRITE TO...”, and use the [+] and [-] buttons to designate a patch number as the destination.*

To change the attack for the second tone, in step 2, set the EDIT TARGET dial to 2ND TONE instead of 1ST TONE, and change the attack in the same manner as before. When you go ahead and actually have the second tone sound, change the LAYER setting using the previously mentioned procedure on p. 34.

* *The attack setting is a method of adjusting a tone's characteristic peculiarities. Accordingly, the width of the change varies with the selected tone.*

Changing Tone Release (RELEASE)

With the RELEASE setting, you can change the length of release time of the first (and second) tones you selected with TONE#. By increasing the release time, you get a slow and easy sound that disappears gradually, even after the strings stop vibrating. With a short release, the sound stops immediately when you mute a string, allowing you to play with sound that has real bite.

<Example of the Procedure to Change the Release>

1. Select patch A43, which you used in selecting the first tone in the section on tone numbers (TONE#), then press [EDIT/PLAY] to enter Edit mode.
2. Set the EDIT TARGET dial to 1ST TONE, and the PARAMETER SELECT dial to "C" (RELEASE).
3. The current value, ranging from -50 to 50 ("0" in the example here) appears in the display.
4. Pressing [+] increases the value setting, lengthening the reverberation time. Press the [-] to decrease the value, shortening the reverberation. (Setting the value to "0" keeps the original sound of the selected tone.)

➤ *The width of the change you can make varies with the selected tone.*

5. When you have set a sound you like, switch the PARAMETER SELECT dial to "WRITE PATCH?", and press the [+] and [-] buttons simultaneously to write the patch.

➤ *When saving to another patch number, before step 5, turn the PARAMETER SELECT dial to "WRITE TO...", and use the [+] and [-] buttons to designate a patch number as the destination.*

To change the release of the second tone, at step 2, set the EDIT TARGET dial to 2ND TONE instead of 1ST TONE, and change the release in the same manner as before. When you go ahead and actually have the second tone sound, change the LAYER setting using the previously mentioned procedure on p. 34.

* *The release setting is a method of adjusting a tone's characteristic peculiarities. Accordingly, the width of the change varies with the selected tone.*

Changing Tone Brightness (BRIGHTNESS)

By setting the BRIGHTNESS of the first (and second) tones that you selected with TONE#, you can change the brightness of the patch. Changing the value adjusts the setting of the internal digital filter (an effect resembling a electronic guitar's tone knob, but reinforced with digital circuitry) making the sound brighter (harder) or darker (softer).

<Example of the Procedure to Change the Brightness>

1. Select patch A43, which you used in selecting the first tone in the section on tone numbers (TONE#), then press [EDIT/PLAY] to enter Edit mode.
2. Set the EDIT TARGET dial to 1ST TONE, and the PARAMETER SELECT dial to "D" (BRIGHTNESS).
3. The current value, ranging from -50 to 50 ("0" in the example here) appears in the display.
4. Pressing [+] increases the value setting, making the sound bright and sharp. Press the [-] to decrease the value, creating a dark, muffled sound. (Setting the value to "0" keeps the original sound of the selected tone.)

➤ *The width of the change you can make varies with the selected tone.*

5. When you have set a sound you like, switch the PARAMETER SELECT dial to "WRITE PATCH?", and press the [+] and [-] buttons simultaneously to write the patch.

➤ *When saving to another patch number, before step 5, turn the PARAMETER SELECT dial to "WRITE TO...", and use the [+] and [-] buttons to designate a patch number as the destination.*

To change the brightness of the second tone, at step 2, set the EDIT TARGET dial to 2ND TONE instead of 1ST TONE, and change the brightness in the same manner as before. When you go ahead and actually have the second tone sound, change the LAYER setting using the previously mentioned procedure on p. 34.

* *The brightness setting is a method of adjusting a tone's characteristic peculiarities. Accordingly, the width of the change varies with the selected tone.*

TONE MIX

Combining/Layering Two Sounds (Tones)

Determining Which Tones Will Be Sounded (LAYER)

Assembly of the first and second tones is performed with TONE MIX LAYER. Here you can elect to have only the first tone, only the second, or both tones sound.

► LAYER combined with STRING SELECT allows you to make settings to each string separately (p. 35). For example, you can do something like dividing strings 1 to 3 and strings 4 to 6, and then assign them different tones.

First, using the following procedure, let's change the setting of all the strings at one time.

<Procedure for Changing the Layer Settings of the First and Second Tones>

1. Select patch A43, which you used in selecting the first tone in the section on tone numbers (TONE#), then press [EDIT/PLAY] to enter Edit mode.
2. Set the EDIT TARGET dial to TONE MIX, and the PARAMETER SELECT dial to "A" (LAYER).
3. Set the STRING SELECT knob on the top panel to "ALL."
4. Pressing the [+] and [-] buttons switches the settings of all the strings simultaneously.

Status of these settings is indicated in the display as shown below. The first (left) place of the display shows the string number, and "A" for "All" is shown here.

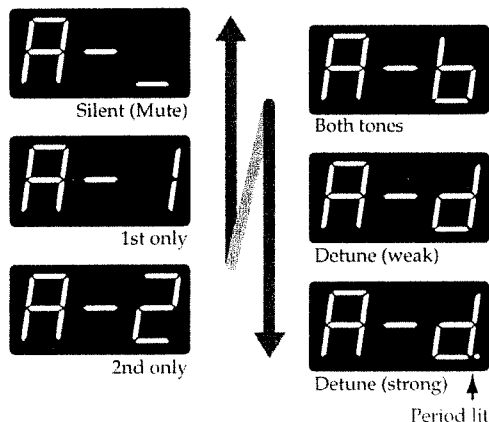

5. When you have set a sound you like, switch the PARAMETER SELECT dial to "WRITE PATCH?", and press the [+] and [-] buttons simultaneously to write the patch.

► When saving to another patch number, before step 5, turn the PARAMETER SELECT dial to "WRITE TO...", and use the [+] and [-] buttons to designate a patch number as the destination.

Applying Detune (Subtle Pitch Shift)

In step 4 of the previous (LAYER) section's settings procedure, when you select either "d" (weak detune) or "d." (strong detune), both the first and second tones are played, and a detune effect that slightly "puts off" the pitch of both tones is added. Strong detune creates much more of a difference in the tones pitch than does weak detune, and giving a deeper detune effect.

Using detune can add thickness to sounds. By applying detune to the same number tones as before, and then using the COMMON "PAN" (p. 39) to split the two tones and pan them, one each to left and right, you can give a feeling of breadth to the sound. Since detune is one of the LAYER settings, used in combination with the STRING SELECT dial, different settings can be made to each string (p. 35).

Transposing by Semitones (TRANS 1ST/2ND)

Ordinarily, with the GR-30, the pitch of the synth sound is the same as the guitar's. When the need arises, you can change this pitch relationship, altering by semitones. This is called transpose. By transposing, you can change the synthesizer's sound by different intervals — an octave, fifth, or the like — and then layer the synth sound with the sound of the guitar.

Also, with the built-in transpose setting, you can separate the transposition of the first ("TRANS 1ST") and second ("TRANS 2ND") tones. Thus, you can achieve a big, fatter sound by for example either transposing both of the synthesizer sounds together, or by lowering one tone by an octave, and raising the other by a fifth on your guitar sound.

➔ When used in combination with the STRING SELECT dial, you can make settings for each string individually. First, using the following procedure, let's change the setting of all the strings together.

<Changing the Transposition of the First Tone>

1. Select patch A43, which you used in selecting the first tone in the section on tone numbers (TONE#), then press [EDIT/PLAY] to enter Edit mode.
2. Set the EDIT TARGET dial to TONE MIX, and the PARAMETER SELECT dial to "B" (TRANS 1ST).
3. Set the STRING SELECT knob on the top panel to "ALL."
4. Pressing the [+] and [-] buttons switches the settings of all the strings simultaneously. The available range of transposition, by semitone units, is -36 to +24. Setting the transposition to "12" raises the sound by one octave; set it to "-24," and the sound is shifted down two octaves.
5. When you get it set to sound the way you like, switch the PARAMETER SELECT dial to "WRITE PATCH?", and press the [+] and [-] buttons simultaneously to write the patch.

➔ When saving to another patch number, before step 5, turn the PARAMETER SELECT dial to "WRITE TO...", and use the [+] and [-] buttons to designate a patch number as the destination.

➔ To change the transposition of the second tone, at step 2, set the PARAMETER SELECT dial to TRANS 2ND (C) instead of TRANS 1ST (B), and change the transposition in the same manner as before. When you go ahead and actually have the second tone sound, change the LAYER setting using the previously mentioned procedure on p. 34.

Choosing Different Settings for Different Strings (STRING SELECT)

By using the STRING SELECT dial in conjunction with the three TONE MIX settings — LAYER, TRANS 1ST, and TRANS 2ND, you can make settings for each string individually.

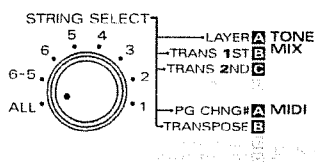

○ When making settings for each string individually, use the [+] and [-] buttons to change settings values, switch the STRING SELECT dial to any of the string numbers 6 to 1. For example, turning the dial to "3," and then pressing the [+] and [-] buttons changes the settings for string 3. (After this, when the STRING SELECT dial is switched to "All," the display starts to flash. This indicates that the identical setting for all the strings is no longer in effect. The number flashing in the display is the setting value for string 1.)

* In LAYER, the number displayed in the first place of the display (the string number) switches to the selected number, allowing you to check and see which string is in the process of having settings made. However, in TRANS 1ST and TRANS 2ND, due to the limited number of places in the display, the string number does not appear. While making these settings, carefully note the position of the STRING SELECT dial.

○ When you want to make settings to all of strings together, switch the STRING SELECT dial to ALL. Pressing the [+] and [-] buttons changes the settings for all the strings simultaneously. If you want to change the settings only on strings 5 and 6, turn the STRING SELECT dial to the 6—5 position. (In LAYER, "L" (Low String) appears in the first place of the display.)

➔ Other individual settings made with the STRING SELECT dial that you can also send to external MIDI devices include tone selection data and transposition. (Refer to MIDI "PG CHNG#" (p. 72) and MIDI "TRANSPOSE" (p. 76).)

Determining the Volume Balance of Two Tones (1:2 BAL)

When the first and second tones are being played simultaneously, you will need to balance the volume of the two tones. You can set this for each patch using the TONE BALANCE setting.

<Balancing the Volume of Two Tones>

1. Select a patch which has LAYER(p. 34) set so both first and second tones play, then press [EDIT/PLAY] to enter the Edit mode.
2. Set the EDIT TARGET dial to TONE MIX, and the PARAMETER SELECT dial to "D" (1:2 BALANCE).
3. With the [+] and [-] buttons, change the values, within a range of -50 to 50. Setting to "50" produces the first tone only and to "-50" produces the second tone only; setting to "0" makes the volumes exactly the same.

4. When you get it set to sound the way you like, switch the PARAMETER SELECT dial to "WRITE PATCH?", and press the [+] and [-] buttons simultaneously to write the patch.

➔ When saving to another patch number, before step 4, turn the PARAMETER SELECT dial to "WRITE TO...", and use the [+] and [-] buttons to designate a patch number as the destination.

* When making this setting, please set LAYER (p. 34) so that both the first and second tones are playing.

What to do When a Tone is Supposed to Sound, but Doesn't

In cases where only the first or second tone can be heard, one of the following may be the cause. Check the following items, and if one of them turns out to be the problem, refer to the specified page, and change the settings.

- All or one of the strings is set to "1" (first tone only) or "2" (second tone only), in LAYER (p. 34).
- 1:2 BAL (p. 35) is set to 50 or -50.
- The tones are panned left and right (50 and -50) with the COMMON PAN setting (p. 39), and the amp is connected with only one channel having sound output.
- When an external expression pedal is connected, with "Ad1," "Ad2," or "bAL" having been selected with that function (p. 49), and the pedal is brought all the way back (or pressed all the way forward).
- Even though Arpeggiator may be on (p. 55), the arpeggio pattern has been erased, or in the ARPEGGIO/harmony SEL setting (p. 55), only one tone has been assigned to the arpeggio.

* When neither the first nor second tones are sounded, please refer to p. 85 and perform the checks described.

COMMON

Setting the Volume Level of Each Patch (PATCH LEVEL)

For things like switching between multiple patches while playing, having the volume of backing patches set lower than the volume of solo patches is a convenient feature. You can make these kinds of volume settings by recording the patch level (PATCH LEVEL) of each patch.

<Determining and Recording Patch Volumes>

1. Select the patch whose volume you want to change, and press [EDIT/PLAY] to go into the Edit mode.
2. Set the EDIT TARGET dial to COMMON, and the PARAMETER SELECT dial to "A" (PATCH LEVEL).
3. With the [+] and [-] buttons, change the values, within a range of 0 to 100. A setting of "0" silences to patch, and "100" sets it to maximum volume.
4. When you get it set to sound the way you like, switch the PARAMETER SELECT dial to "WRITE PATCH?", and press the [+] and [-] buttons simultaneously to write the patch.

➔ When saving to another patch number, before step 4, turn the PARAMETER SELECT dial to "WRITE TO...", and use the [+] and [-] buttons to designate a patch number as the destination.

* Even with PATCH LEVEL values the same, volume levels may change according to other settings. In the example below, the level has been set high. If PATCH LEVEL is then set to a low level, the balance of another patch is used. (The combination of the settings shown below may cause excessively high volume levels, so be careful not to allow this to result in damage to amps and speakers.

- When both the first and second tones are present.
- When the reverb is set to a high level, or when the chorus effect is on.
- When a high volume level is a characteristic of the tone itself.
- When the brightness setting value is high.
- When wah effects are applied.

Changing the Feel of a Performance (PLAY FEEL)

Guitars differ from keyboards and other instruments in that the part of the instrument that actually vibrates (i.e. the string) is touched directly, allowing subtle control of the power with which it is played. To let the guitar synthesizer make maximum use of this feature, it is necessary to set the "playing response."

This selection is made with "PLAY FEEL" in the COMMON setting. For example, by changing the Play Feel options like "finger picking" or "normal picking," you can get very natural-sounding expression of how much power is in the playing.

<Changing and Recording Play Feel>

1. Select the patch, and press [EDIT/PLAY] to go into the Edit mode.
2. Set the EDIT TARGET dial to COMMON, and the PARAMETER SELECT dial to "B" (PLAY FEEL).
3. With the [+] and [-] buttons, change the values in the range shown under ♦ below.
4. When you get it set to sound the way you like, switch the PARAMETER SELECT dial to "WRITE PATCH?", and press the [+] and [-] buttons simultaneously to write the patch.

➔ *When saving to another patch number, before step 4, turn the PARAMETER SELECT dial to "WRITE TO...", and use the [+] and [-] buttons to designate a patch number as the destination.*

♦ There are eight types of effect that can be selected in step 3.

Select one of the following: "nor"; "Fin"; "Hrd"; "Sft"; "tAp"; "no.d"; "EF1"; or "EF2"; then when you press the [+] button, a period will appear in the display, right after the last digit of the selected setting ("nor."; "Fin."; "Hrd."; and so on), and the selection is set. (In the "Accelerator" function mentioned later, the period indicates that the function is on. See p. 38.)

Display names and meanings are as follows:

nor (normal)

General picking, thus the standard setting for play.

Fin (finger picking)

The setting for when you want to perform with the feeling finger picking provides. Sensitivity is a little higher than with normal picking.

Hrd (hard picking)

This setting is for those who pick rather hard, and the sensitivity is a little lower than with normal picking.

** When there is a problem with the guitar's arrangement, and the only places GK-2A's divided pickup can be installed are too close to the strings, you may be able to improve the behavior with the settings in each patch.*

Sft (soft picking)

For picking that is a little weaker. Sensitivity is a little higher than with normal picking.

tAP (tapping play)

When making use of many kinds of picking techniques, such as tapping play (or "right-hand play"), pulling-off, or hammering-on, this setting provides very stable sound expression. The range of power that can be expressed is a bit narrow.

no.d (no dynamics)

With this setting, no matter how hard or softly you play, you get uniform volume and tone. Use this setting with tones like Synth Lead or Organ when you want to transmit a feeling without expression.

EF1 (envelope follow type 1)

This is for setting how much the synthesizer volume influences the amplitude of the strings. (For more detailed information about this, see the following section.)

EF2 (envelope follow type 2)

This is for setting how much the overall tone (brightness) influences the amplitude of the strings. (For more information about this, see the following section.)

** Picking strength and power range vary from player to player. The names of these settings ("normal," "hard," and so on) are for easy reference only, so you are encouraged to actually switch through the settings, and when you find ones that you feel are easy to play, that you feel have characteristics of instruments you'd like to play, paying no special attention to their names, go ahead and select those settings.*

For example, by choosing "Fin" for picking the Synth Lead tone, and "tAP" for an organ-type sound, you can convey imagery when you play, and it's no problem since it'll be easy to play.

Following the Guitar Sound Shape (Envelope Follow)

When you select the EF1 and EF2 settings in the above PLAY FEEL section, the envelope follow function comes on, giving you that effect.

In this condition, changes in the strings' amplitude (changes due to picking, or from how the sound decays) are influenced by the volume or tone of the synthesizer sounds. You can get the following types of effects.

EF1 (envelope follow type 1)

Here, the synthesizer volume influences the amplitude of the strings. You can get a natural feel when using decay tones (from guitars, electronic pianos, and so forth), so do try this setting. (Change in the synth sound's volume is a little more compressed, a bit more restrained than that of the guitar.

EF2 (envelope follow type 2)

This is for setting how much the overall tone (brightness) is influenced by the amplitude of the strings. Along with the decay, which depends on the picking strength and time elapsed, this setting changes the sound's brightness (regulation of muffled sound) dynamically. Especially with Synth Lead tones, you can get that tone's characteristic effect. The following procedure, combined with the wah auto effect trigger, you can get a touch wah effect with extremely smooth response.

<Getting a Touch Wah Effect with the PLAY FEEL "EF2" Setting>

1. Let's select the Synth Lead tone F82.
2. In the Edit mode, set the EDIT TARGET dial to COMMON, and the PARAMETER SELECT dial to "B" (PLAY FEEL), and with the [+] and [-] buttons, select "EF2."
3. Set the EDIT TARGET dial to [FOOT PEDAL], and the PARAMETER SELECT dial to "A" (WAH TYPE), and with the [+] and [-] buttons, select "At3" (auto trigger).
4. Play the guitar to confirm that the wah effect is responding to the strength of the picking. Additionally, change the brightness of the sound with the 1ST TONE "BRIGHTNESS" as well as the setting you selected in step 3, from "At1" to "At5" until you get an effect you like.

* When saving to a patch, turn the PARAMETER SELECT dial to "WRITE TO...", and use the [+] and [-] buttons to designate a patch number as the destination. Then, turn the same dial to "WRITE PATCH?", and press the [+] and [-] buttons simultaneously to write the patch.

* When EF1 or EF2 is selected for PLAY FEEL, the envelope follow data will be sent from MIDI OUT as controller no. 18 (general purpose controller 3).

Increasing the Speed of Expression (Acceleration)

When you are making selections in PLAY FEEL (p. 37), when items containing a period in the lower right corner of the display's third place (nor., Fin., Hrd., and so on) are selected, the GR-30's "Acceleration Function" is turned on. When put in this mode, the average speed from picking to sound is higher than usual.

However, when this function is being used, the effect of internal processing of string noise abatement that is working at the time the synth sound of the same string is continuing is weakened. Depending on the accompanying tone, you may notice a "popping" noise, so please be mindful of this. If you use the Accelerator function, please confirm when you're creating a sound that there is no bothersome noise in the tone you are using.

* Of the preset patches, only E13 has Accelerator turned on (although this is also true for A13 when the GR-30 is purchased). Thus, when carrying out changes to tones based on this patch, make sure there is no popping noise, and if necessary, turn Accelerator off by changing the settings in COMMON "PLAY FEEL."

* The Acceleration function has no effects on the sounds played by an external MIDI sound generator.

Changing Sound Placement (PAN)

You can give the first and second tones different auditory placement, for example placing the two tones left and right in a stereo arrangement.

Also, changing the settings changes the placement of the sound, so you can do things like set the placement of each string in irregular patterns. This is done with the COMMON "PAN" setting.

<Setting and Saving Sound Placement>

1. Select the patch whose placement you want to set, and press [EDIT/PLAY] to go into the Edit mode.
2. Set the EDIT TARGET dial to COMMON, and the PARAMETER SELECT dial to "C" (PAN).
3. Press the [+] and [-] buttons to change the display. (Display shows -50 to +50, 1-6, 6-1, o-E, E-o, rnd, 1.rd, 2.rd, Alt, 1.AL, or 2.AL.)

For more on the effects that you can get with each setting, refer to ♦ below.)

4. When you get it set to sound the way you like, switch the PARAMETER SELECT dial to "WRITE PATCH?", and press the [+] and [-] buttons simultaneously to write the patch.

➔ *When saving to another patch number, before step 4, turn the PARAMETER SELECT dial to "WRITE TO...", and use the [+] and [-] buttons to designate a patch number as the destination.*

♦ PAN Values (Display) and the Effects of Their Settings

-50 to 0 to 50

With the setting at "0," all sound is placed in the center. By changing the values in a range of -50 to 50, panning changes continuously, and with the first tone 50 places it completely to the right, and -50 all the way to the left. Conversely, setting the second to -50 places the sound to the left, and a setting of 50, the sound is placed to the right. Therefore, by setting a patch using both tones to a value near 50 or -50, you can make it a patch with a rich, widespread stereo sound.

1-6, 6-1

With this setting each string is panned separately. When you select 1-6, the strings's sounds are placed in sequence from the left, string 1, string 2, ..., string 6. Conversely, with 6-1, the opposite arrangement is set, i.e. string 6, string 5, all the way to string 1. (Example of a patch using this: E52.)

o-E, E-o (odd, Even)

This setting separates odd- and even-numbered strings, and places the left and right. With o-E, the odd-numbered strings (1, 3, and 5) are panned left, and the even-numbered strings (2, 4, and 6) panned right. With E-o, left and right are switched, but the effect is the same. (Example of a patch using this: G84.)

rnd, 1.rd, 2.rd (rnd/rd = random)

The sound placement of the first and second tones changes randomly. (Example of a patch using this: G82.) "1.rd" and "2.rd" set only the first or second tone respectively to this random placement. The other tone is placed in the center.

Alt, 1.AL, 2.AL (Alt/AL = alternate)

The placement of both the first and second tones switches repeatedly between left and right. For patches having only one tone playing, the tone plays crosses back and forth from both left and right. With a patch using both tones, but with the first tone to the right and the second tone to the left, this gives a special stereo effect that differs from that you get with the "rnd" (random) setting. (Example of a patch using this: E81.)

"1.AL" and "2.AL" set only the first or second tone respectively to this alternate placement. The other tone is placed in the center.

* *Pan settings have no effect on the internal reverb and chorus.*

* *You can get the panning effects using these of pan settings only with equipment that can produce stereo sound connected with two cables, or when using stereo headphones. Furthermore, while you can use the MIX OUT [R] as a second stereo headphone jack, please understand that the left and right output of [L] will be reversed.*



Dividing Continuous Pitch Changes into Semitones (CHROMATIC)

The GR-30 faithfully reproduces the slight pitch changes and in-between tones you get from pressing the strings.

However, as the need arises you can also limit this subtle pitch expression to semitone changes. This is called the Chromatic function, and is turned on and off the COMMON "CHROMATIC" setting.

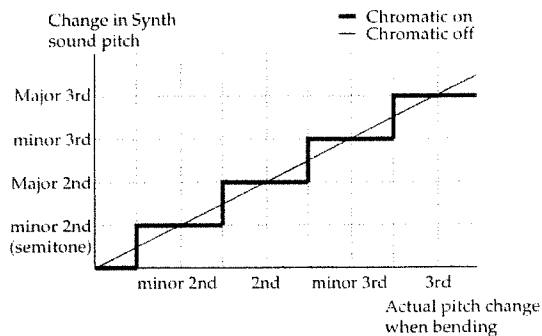

<Turning the Chromatic Function On and Off and Saving It to Patches>

1. Select the patch you want to change, and press [EDIT/PLAY] to go into the Edit mode.
2. Set the EDIT TARGET dial to COMMON, and the PARAMETER SELECT dial to "D" (CHROMATIC).
3. Press the [+] and [-] buttons to change the display. (Displays show: oFF, on1, on2, and on3. Refer to ♦.)
4. When you get it into the condition you want, switch the PARAMETER SELECT dial to "WRITE PATCH?", and press the [+] and [-] buttons simultaneously to write the patch.

► When saving to another patch number, before step 4, turn the PARAMETER SELECT dial to "WRITE TO...", and use the [+] and [-] buttons to designate a patch number as the destination.

◆ Chromatic Settings and Available Effects

oFF (Chromatic Off)

For guitar bending and vibrato, with this setting, you can have synth sounds faithfully reproduce the subtle pitch changes of less than a semitone.

When you switch this on, pitch changes are limited to semitones.

on1 (On 1)

With "on1", when getting changing pitch by semitones from guitar bending, only the pitch change information only is added and processed, without the sound being stopped. There is no attack sound when the pitch changes, which is characteristic of the change like the kind you get with the slurred playing of a recorder.

on2 (On 2)

With "on2", as with the above, when you change the pitch, the sound of the appropriate pitches is retriggered, expressing semitone pitch change. Thus, whenever the pitch changes, you hear the attack.

If the retrigger occurs during the decay in the string vibration from the time the string was played, the retriggered sound gradually diminishes.

on3 (On 3)

This is basically the same effect as "on2", except that the retriggered sound level is not influenced by the attenuation of the string vibration.

When You Want to Make a Chord Resonate Beautifully

With patches using long notes, then because of the subtle pitch changes from the way each string is pressed, reverberation of the chords may end up sounding muddy.

At such times, when you turn Chromatic on, the intervals in the composition of a sound are preserved, producing a beautiful chord sound. Especially if you select "on1", pitch changes are barely audible, giving a natural-sounding resonance.

Change the setting of a patch such as E44 from "oFF" to "on1" to confirm that no muddiness in the sound is present when the effect is on.

When You Want to Reproduce Piano-like Pitch Changes

In patches assuming instruments that cannot express pitch changes smaller than a semitone, switching on Chromatic better allows those instruments' sounds.

In such cases, when "on2" or "on3" is selected, the attack is reproduced with each pitch change. (Depending on the tone or melody, there may be times when "on1" or "oFF" yield a better effect, so select the setting you like.)

Chapter 6: Using the Built-in Effects

About the Effects Processors and Available Effects

The GR-30 includes two effects, reverb and chorus, to use on synthesizer sounds.

Reverb is an effect that simulates the reverberation you get when performing in a room or hall with good acoustics. With the GR-30's built-in reverb, you also get delay (an effect that repeats a sound, sort of like a mountain echo).

Chorus is an effect that gives a wide, open sound, with a special type of wavering, like that of multiple instruments playing together. With the GR-30's built-in chorus, you also get flanger (an effect that gives the sharp metallic sound of a jet airplane flying around) as well as a very short delay effect.

Reverb and Chorus are connected as shown in the chart.

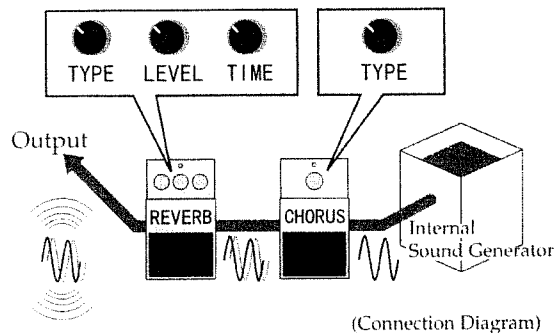

* These effects are for use with the built-in sound generator. They don't work with guitar sounds or any other than the internal synth sound generator. However, if you use the GUITAR OUT (RETURN) jack, you can make additional connections to add external guitar-only effects (p. 13).

Adjusting the Effects (EFFECT)

With the GR-30 you can pick one of eighteen different preset reverb types, and then freely make your own settings to reverb amount and length.

Depending on the type you select, delay (an effect that repeats a sound, sort of like a mountain echo), is also available.

Selecting Reverb Type (REVERB TYPE)

<Selecting Reverb Type and Saving It to Patches>

1. Select the patch whose reverb type you want to change, and press [EDIT/PLAY] to go into the Edit mode.
2. Set the EDIT TARGET dial to EFFECT, and the PARAMETER SELECT dial to "A" (REVERB TYPE).
3. When you press the [+] and [-] buttons, the display changes. (Display shows OFF, ro1 to ro3, HL1 or HL2, PLt, dL1 to dL6, or Pd1 to Pd6. For more on the effects that you can get with each setting, refer to ♦.)
4. When you get the type you want, switch the PARAMETER SELECT dial to "WRITE PATCH?", and press the [+] and [-] buttons simultaneously to write the patch.

➔ When saving to another patch number, before step 4, turn the PARAMETER SELECT dial to "WRITE TO...", and use the [+] and [-] buttons to designate a patch number as the destination.

♦ Selectable Reverb Variations

oFF

The patch's reverb is turned off.

ro1 to ro3 (Room 1 to 3)

This simulates room reverb. Choose from three types of reverb to match the particular tone you are using.

HL1 to HL2 (Hall 1 to 2)

This setting gives a large hall reverb. HL2 gives a huge hall sound.

PL (Plate)

This reproduces the sound of plate reverb, the kind of reverb that is used in recording vocals in the studio. This kind of reverb is popular for its characteristically beautiful, sparkling sound.

dL1 to dL6 (Delay 1 to 6)

Gives a delay effect. There are six settings, with the number of repeats increasing as you change from 1 to 6.

Pd1 to Pd6 (Panning Delay 1 to 6)

This is a special delay effect, where the output of the delay's repeating alternates between left and right MIX OUT. There are six settings, with the number of repeated sounds increasing as you change from 1 to 6.

Selecting Reverb Levels and Times (REVERB LEVEL, REV/DLY TIME)

After selecting the type of reverb, let's adjust the reverb amount and time to fit the feeling of the selection.

<Determining Reverb Amount and Time and Saving Them to Patches>

1. Select the patch you want to adjust, and press [EDIT/PLAY] to go into the Edit mode.
2. Set the EDIT TARGET dial to EFFECT, and the PARAMETER SELECT dial to "C" (REV/DLY TIME).
3. With the [+] and [-] buttons, change the values, within a range of 0 to 100, changing the delay time. ("0" is the minimum, and "100" the maximum delay time.)
4. When you get the reverb time set the way you want, switch the PARAMETER SELECT dial to "B" (REVERB LEVEL).
5. Use [+] and [-] to change the value within the range of 0 to 100, this time changing the reverb sound level. ("0" is the minimum, and "100" the maximum reverb level.)
6. When you're done setting the reverb level, switch the PARAMETER SELECT dial to "WRITE PATCH?", and press the [+] and [-] buttons simultaneously to write the patch.

➤ *When saving to another patch number, before step 6, turn the PARAMETER SELECT dial to "WRITE TO...", and use the [+] and [-] buttons to designate a patch number as the destination.*

➤ *When you select a delay effect with REVERB TYPE (dL1 to dL6, Pd1 to Pd6), delay time will change when you change the REV/DLY TIME setting.*

Selecting Chorus Type (CHORUS TYPE)

The GR-30's built-in chorus features 25 variations of chorus types, where the effect of parameters such as sweep depth and speed differ with each type. These are preset effects, so selecting just the right one of the various tones is a snap.

* *The amount of chorus effect is automatically set with for the selected chorus type.*

<Procedure for Selecting Chorus Type and Saving It to Patches>

1. Select the patch whose chorus type you want to change, and press [EDIT/PLAY] to go into the Edit mode.
2. Set the EDIT TARGET dial to EFFECT, and the PARAMETER SELECT dial to "D" (CHORUS TYPE).
3. When you press the [+] and [-] buttons, the display changes. (Display shows OFF, Cr1 to 9, FL1 to FL9, SD1 to SD6, or SE1 or 2. For more on the effects that you can get with each setting, refer to ♦ below.)
4. When you have selected the type, switch the PARAMETER SELECT dial to "WRITE PATCH?", and press the [+] and [-] buttons simultaneously to write the patch.

➤ *When saving to another patch number, before step 4, turn the PARAMETER SELECT dial to "WRITE TO...", and use the [+] and [-] buttons to designate a patch number as the destination.*

♦ Selectable Chorus Variations

oFF (Off)

Turns off the chorus in the patch.

Cr1 to Cr3 (Chorus 1 to 3)

Standard chorus effect. The sweep speed increases as settings go from 1 to 3.

Cr4 to Cr6 (Chorus 4 to 6)

These are deeper chorus effects. Sweep increases as settings go from 4 to 6.

Cr7 to Cr9 (Chorus 7 to 9)

This effect has only a slight sweep for a natural chorus width. The effect deepens as settings go from 7 to 9.

FL1 to FL3 (Flanger 1 to 3)

A shallow flange effect. The speed of the wavering increases as settings go from 1 to 3.

FL4 to FL6 (Flanger 4 to 6)

The robust, metallic reverberation of this flanger is a very up-front sound. The speed of wavering increases as settings go from 4 to 6.

FL7 to FL8 (Flanger 7 to 8)

Resembling chorus, these settings feature softer reverberation. "FL8" creates a faster undulation than "FL7."

Sd1 to 6 (Short Delay 1 to 6)

An extremely short delay. There are six settings, each with different delay times and repeats.

SE1 and SE2 (Special Effect 1 and 2)

This add special effects to the synthesizer sound (two types.)

Temporarily Turning Off Effects (EFFECT BYPASS)

When you want to compare a sound with and without effect, and while you are making various settings in the process of creating a patch, there will be times when you'll want a simple way to turn the internal reverb and chorus on and off. You get this kind of convenience with the Effect Bypass.

<Temporarily Turning Off an Effect>

1. While in any status, when you press [+] while holding down [EDIT/PLAY], the green "EFFECT BYPASS" light on the five-light indicator will come on, and without any of the settings changed, the reverb or chorus will fall silent.

2. When you again press [+] while holding down [EDIT/PLAY], the indicator light goes off, and you are returned to normal conditions.

** Since Effect Bypass remains a temporary condition throughout, the bypass conditions are not preserved even when saving to patches or if the power is turned off. To turn off an effect in an individual patch, select the "oFF" setting in either REVERB TYPE (p. 42) or CHORUS TYPE (p. 43) and store that setting in the patch.*

What to do if Built-in Effects Cannot Be Heard

If the built-in reverb or chorus is having no effect, double-check reconfirm each of the following:

- Check whether the EFFECT BYPASS indicator light is on.
- See if the "oFF" setting in either REVERB TYPE (p. 42) or CHORUS TYPE (p. 43) is selected.
- See if the REVERB LEVEL (p. 43) value is adjusted to a suitable level.
- If the "rE.L" (REVERB LEVEL) function is selected, make sure that the EXP pedal is not rocked back all the way.

Chapter 7: Setting and Changing the Way Pedal Effects Work

FOOT PEDAL

By switching into Pedal Effect mode, or while in the Play mode setting the PARAMETER SELECT dial to PATCH INC/DEC BY S1/S2, you can add effects like hold, pitch bend, wah pedal, and the like to the synth sounds by pressing the base module pedals.

There are numerous variations in the way these effects work, so you can freely choose the ones that suit your own purpose, taste, or otherwise to match the song you are playing

Selecting Wah Types (WAH TYPE)

There are 35 types, in seven groups, of wah effects you can get by stepping on and releasing pedal 1, with differing ranges of tone change and different speeds, and along with one type of modulation (vibrato), there are a total of 36 variations of wah pedal effects.

<Selecting Wah (or Modulation) Type>

1. Select the patch whose effect type you want to change, and press [EDIT/PLAY] to go into the Edit mode.
2. Set the EDIT TARGET dial to FOOT PEDAL, and the PARAMETER SELECT dial to "A" (WAH TYPE).
3. When you press the [+] and [-] buttons, the display changes. (Display shows UA1 to UA5, At1 to At5, br1 to br5, nU1 to nU5, -U1 to -U5, -b1 to -b5, -n1 to -n5, or Mod. For more on the effects that you can get with each setting, refer to ♦ below.)
4. When you have selected the type, switch the PARAMETER SELECT dial to "WRITE PATCH?", and press the [+] and [-] buttons simultaneously to write the patch.

➤ When saving to another patch number, before step 4, turn the PARAMETER SELECT dial to "WRITE TO...", and use the [+] and [-] buttons to designate a patch number as the destination.

➤ When making settings, play the guitar with pressing pedal 1 to try the effect.

♦ Wah Pedal Variations that can be selected in step 3

➤ The number (1 to 5) in the third place of the display indicates speed of the tone change. When you step on and release the pedal, the numbers show, with "1" indicating the fastest tone change, and as these numbers get larger, the speed decreases.

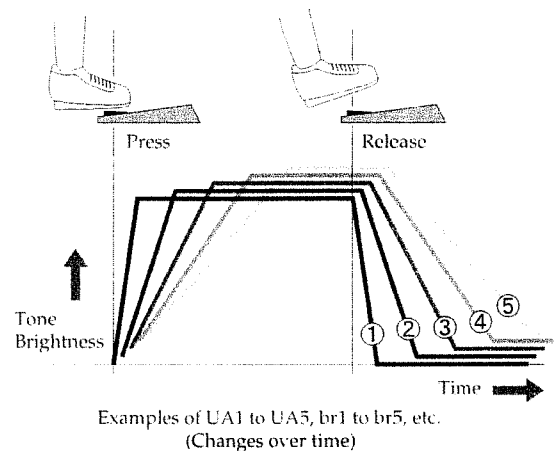

UA1 to UA5 (Wah 1 to 5)

This adds an effect that resembles a guitar wah pedal to the synthesizer sound. With this unique effect added to the sound, stepping on the pedal gives the tone a brighter "wah" sound, and when the pedal is released, the sound becomes darker, with an "oww" sound. By repeatedly stepping on and releasing the pedal, you can get an effect that sounds like "wah wah wah."

At1 to At5 (Auto Trigger 1 to 5)

This is basically the same effect as the wah pedal (UA1 to UA5), but rather than being applied with the pedal, with this novel method, the effect is automatically applied each time the guitar is picked. In this situation, the pedal still works to add affect, so you can use both of these options together. When combined with the Play Feel setting "EF2" on tones like Synth Bass, you can get a smooth "touch wah" effect (p. 38).

br1 to br5 (Brightness 1 to 5)

This controls only the brightness of the sound, without adding the characteristic sound of the wah itself. In all other actions, it is absolutely identical to UA1 to 5.

nU1 to nU5 (Narrow Wah)

This compresses the tone difference from stepping on and releasing the pedal to half the range of the normal wah (UA1 to 5). In all other actions, it is absolutely identical to UA1 to 5.

-U1 to -U5 (Reverse Wah 1 to 5)

This reverses the tones from stepping on and releasing the pedal in normal wah (UA1 to 5) (i.e. step → dark sound, release → bright).

-b1 to -b5 (Reverse Brightness 1 to 5)

This reverses the tones from stepping on and releasing the pedal in the brightness setting (b1 to 5) (i.e. step → dark sound, release → bright).

-n1 to -n5 (Reverse Narrow 1 to 5)

This reverses the tones from stepping on and releasing the pedal in Narrow (n1 to 5) (i.e. step → dark sound, release → bright).

Mod (Modulation)

When you select this setting, as you step on the pedal, then rather than a wah-type effect, a deep vibrato (wavering pitch) effect is added. Differing from the mood created by playing finger vibrato on the guitar, it gives a mechanical, synthesizer-sounding vibrato.

The speed and depth of the vibrato you get with this function is predetermined for each tone. Furthermore, when the pedal is pressed, "Mod," not "UAH" appears in the display when "Mod" is selected.

- * *If you use wah once, the sound from a patch with a muffled sound may continue, or some other kind of peculiarity may change, even after releasing the wah pedal. If this happens, switch to another patch, and then call up the desired patch again to return to the original sound.*
- * *When the wah is "closed," that is, the sound of the wah effect is too dark (or muffled), switch WAH TYPE to either "nU1 to 5" or "-n1 to 5," and adjust this by changing the Brightness (p. 33) setting.*
- * *The application of wah-type effects varies with the selected tone.*

Selecting Pitch Glide Type (GLIDE TYPE)

With the Pitch Glide you get by pressing pedal 2, there are nine different ways to have the pitch change width and speed, with both up and down patterns prepared.

<Selecting Pitch Glide Type>

1. Select the patch whose effect type you want to change, and press [EDIT/PLAY] to go into the Edit mode.
2. Set the EDIT TARGET dial to FOOT PEDAL, and the PARAMETER SELECT dial to "B" (GLIDE TYPE).
3. When you press the [+] and [-] buttons, the display changes. (Displays show: dn9, dn8, ..., dn1, uP1, uP2, ..., and uP9. For more on the effects that you can get with each setting, refer to ♦.)
4. When you have selected the type, switch the PARAMETER SELECT dial to "WRITE PATCH?," and press the [+] and [-] buttons simultaneously to write the patch.

➔ *When saving to another patch number, before step 4, turn the PARAMETER SELECT dial to "WRITE TO...", and use the [+] and [-] buttons to designate a patch number as the destination.*

➔ *When making settings, play the guitar while pressing pedal 1 to try the effect.*

♦ Selectable Effect Variations from Step 3

Below are the nine types of effect you can select from. These have been set as both "pitch up" and "pitch down," giving you eighteen effects to choose from. For example, "Up Type '5'" is indicated by "uP5" and "Down Type '3'" by "dn3."

uP1 (dn1)

When the pedal is pressed, the pitch changes continuously only by a perfect fourth. Release the pedal to return to the original pitch.

uP2 (dn2)

Just as in uP1 (dn1), the pitch change is a perfect fourth, but the time it takes to make the change is a little longer.

uP3 (dn3)

When the pedal is pressed, the pitch changes continuously only by a perfect fifth. Release the pedal to return to the original pitch.

uP4 (dn4)

When the pedal is pressed, the pitch changes continuously by one octave. Release the pedal to return to the original pitch.

uP5 (dn5)

The pitch change here is an octave, but the time it takes to make the change is a little longer. (The return time is the same as in uP4 (dn4)).

uP6 (dn6)

The pitch change in this effect is an octave, but both the time for the pitch to change and the return time are longer.

uP7 (dn7)

When the pedal is pressed, the pitch changes continuously by two octaves. Release the pedal to return to the original pitch.

uP8 (dn8)

The pitch change in this effect is two octaves, but both the pitch change and the return are extremely slow.

uP9 (dn9)

Press the pedal for an instant one-octave rise (or drop).

** The pitch change width when "Pit" or "t.n.P." is assigned to an external expression pedal (EXP pedal p. 49) also corresponds to the selection in GLIDE TYPE (fourth, fifth, one octave, or two octaves).*

** With the Pitch Glide function, depending on the tone and range, the width of the pitch's rise may be limited.*

Selecting Hold Type (HOLD TYPE)

With the Hold function on pedal 3, for the qualities such as the sustaining of a tone's sounding, there are fifteen ready-made variations that can be selected according to the particular purpose, and saved to patches.

<Selecting Hold Type>

1. Select the patch whose effect type you want to change, and press [EDIT/PLAY] to go into the Edit mode.
2. Set the EDIT TARGET dial to FOOT PEDAL, and the PARAMETER SELECT dial to "C" (HOLD TYPE).
3. When you press the [+] and [-] buttons, the display changes. (For more on the effects that you can get with each display, refer to ♦.)
4. When you have selected the effect you want, switch the PARAMETER SELECT dial to "WRITE PATCH?", and press the [+] and [-] buttons simultaneously to write the patch.

➤ *When saving to another patch number, before step 4, turn the PARAMETER SELECT dial to "WRITE TO...", and use the [+] and [-] buttons to designate a patch number as the destination.*

➤ *When making settings, play the guitar while pressing pedal 1 to try the effect.*

♦ Selectable Effect Variations in Step 3

There are three types of hold effects you can select: damper; sostenuto; and string.

○ Damper Hold/dPr

When you play the guitar while holding down the pedal, the sound is sustained while playing continues, an effect like that of a piano's damper pedal. When you hold the pedal down, you can play chords without letting the sound from all the notes played die away.

However, even during Hold you cannot play the same string more than once in an attempt to layer the synth sounds coming from the same string.

** The guitar recognizes the pitch only as long as the string continues to vibrate, and this is reflected in the pitch of the synth sound at all times.*

○ Sostenuto Hold/SoS

When you press the pedal, only the synth sound being played at the instant you press the pedal is sustained.

From the moment you go into Hold, to when the pedal is released, the sustained synth sound remains unaffected, even when you continue to play the guitar. Thus, it is convenient for things like holding a synth sound chord and layering it with a guitar melody, or for when you want to make the same effect using the first and second tones.

(Strictly speaking, it isn't but) the Hold effect is very much like the sostenuto pedal of an electronic piano.

○ String Hold/Str

You can apply this hold effect to the strings of your choice. As with "SoS" above, the synth sound being played at the instant you press the pedal is sustained, and continues even if the string stops vibrating.

What's different is that even without releasing the pedal, the synth sound from strings not being held can still be controlled with the guitar. This makes it possible to do things like hold the synth sound on strings 5 and 6, and play a melody over that with synth sound played by strings 1 through 4.

Releasing the pedal stops both the sound being played with the guitar as well as the held sound.

Here are the fifteen types, which can be selected by using the [+] and [-] buttons, as they actually appear (when Arpeggiator is off).

dPr

This damper hold works on all internal and external MIDI sound generators.

d.-1

This damper hold works only on the first internal sound generator.

d.-2

This damper hold works only on the second internal sound generator.

d.-b

This damper hold works on both the first and second internal sound generators. (Not effective on external sound generators.)

d.-E

This damper hold works only on external MIDI sound generators.

d.1E

This damper hold works on the first internal sound generator and on external MIDI sound generators.

d.2E

This damper hold works on the second internal sound generator and on external MIDI sound generators.

SoS

This sostenuto hold works on all internal and external MIDI sound generators.

S.-1

This sostenuto hold works only on the first internal sound generator.

S.-2

This sostenuto hold works only on the second internal sound generator.

S.-b

This sostenuto hold works on both the first and second internal sound generators. (Not effective on external sound generators.)

s.-E

This sostenuto hold works only on external MIDI sound generators.

S.1E

This sostenuto hold works on the first internal sound generator and on external MIDI sound generators.

S.2E

This sostenuto hold works on the second internal sound generator and on external MIDI sound generators.

Str

This string hold works on all internal and external MIDI sound generators.

➤ *When Arpeggiator is on, the fifteen choices shown above are reduced to four: "dPr"; "SoS"; "Lt.A"; and "Lt.B". At such times, the Hold function is effective only on arpeggios, and you can use it in special ways such as changing the arpeggios to chords without the rhythm of the arpeggios being stopped. For more detailed information about this, please refer to (p. 53).*

Using External Expression Pedals (EV-5 or Other)

By connecting an external expression pedal (EXP pedal), you can use the pedal in adding various effects to synth sounds. You can choose from fifteen effects that can be controlled with the EXP pedal, including pitch, volume, Arpeggiator tempo, and the like.

You can also use the EXP pedal in sending MIDI data, and for setting control change numbers as well. All of the above settings can be saved to patches.

To Add Effects

Plug an EXP pedal, such as a model EV-5 (sold separately) into the EXP PEDAL jack on the rear panel. Use the EXP pedal in any mode, and the effect set to the patch called up at that time will immediately be applied.

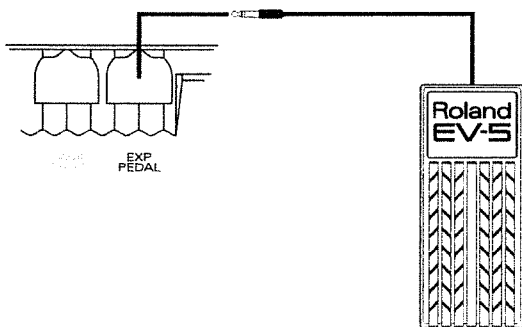

* After the EXP pedal has been used to add some effect to whatever patch was called up, and then you switch to another patch, regardless of the pedal's position, the pedal effect is canceled momentarily, and the patch that has been called up will play in its basic original condition. After switching a patch, the actions of the EXP pedal influence the sound from the moment the pedal first moves again.

However, if the volumes of the patches both before and after switching are controlled by the EXP pedal, the volume corresponding to the position of the EXP pedal before the switch remains.

To Switch Effects (EXP PEDAL)

<Selecting the Expression Pedal Effect Type>

1. Select the patch whose effect type you want to change, and press [EDIT/PLAY] to go into the Edit mode.
2. Set the EDIT TARGET dial to FOOT PEDAL, and the PARAMETER SELECT dial to "D" (EXP PEDAL).
3. When you press the [+] and [-] buttons, the display changes. (For more on available changes and the effects that you can get with each setting, refer to ♦ below.)
4. When you have selected the effect you want, switch the PARAMETER SELECT dial to "WRITE PATCH?", and press the [+] and [-] buttons simultaneously to write the patch.

► When saving to another patch number, before step 4, turn the PARAMETER SELECT dial to "WRITE TO...", and use the [+] and [-] buttons to designate a patch number as the destination.

► When making settings, play the guitar while pressing pedal 1 to try the effect. At this time, it is suggested that you set the EXP pedal's minimum volume to the lowest setting.

♦ Selectable Effect Variations in Step 3

Vol (Volume)

Adjusts the volume level, from zero up to the level set with the GK-2A's volume knob.

Ad1 (Add First Tone)

Controls the volume of only the first tone. In patches using both tones, you get the effect of the first tone being added to the second.

Ad2 (Add Second Tone)

Controls the volume of only the second tone. In patches using both tones, you get the effect of the second tone being added to the first.

bAL (Balance)

Changes the balance of the first and second tones. With the pedal all the way open (return position), only the first tone is heard, and when pressed completely down, only the second tone plays.

bri (Brightness)

Gives continuous change of synth sound brightness.

UAH (Wah)

Resembles a guitar wah-wah pedal, with a lot of that peculiar sound in the tone change.

Pit (Pitch)

While preserving the structure of a chord, greatly changes the pitch of the synthesizer's sound. With the pedal back, the sound is as usual. The width of the pitch change follows the change width setting selected in Pedal Effect mode's GLIDE TYPE. (Setting procedure on p. 46.)

Mod (Modulation)

Changes the depth of pitch undulation applied to the synth sound, from zero to maximum change. (The speed of the wavering sound depends on the predetermined setting of the tones selected with TONE#.)

L-r (Left-Right)

PAN (p. 39) settings in the patch are ignored, and the placement changes in accordance with the EXP pedal's operation. Both first and second tones are panned right when the pedal is pressed forward, left when the pedal is brought back.

PAn (Pan/PAN Setting)

Uses the pedal to directly give the effect of changing the values in a patch's PAN settings (p. 39) in a range of -50 to 50. The first tone is panned right with the pedal pressed forward, and left with the pedal all the way back. The left tone has opposite placement.

rE.L (Reverb Level)

Changes reverb level with the EXP pedal. (Does not affect chorus level.) When the pedal is pressed forward, the reverb level set in the patch is added; no effect is added with the pedal all the way back.

tp1 (Tempo Type 1)

Changes arpeggio tempo. When the pedal is pressed forward, the arpeggio plays at the tempo set in the patch, and with the pedal all the way back, the tempo becomes extremely slow.

tp2 (Tempo Type 2)

Changes arpeggio tempo. When the pedal is pressed forward, the tempo becomes extremely fast, and with the pedal all the way back, the tempo returns to that set in the patch.

tp3 (Tempo Type 3)

Adjusts arpeggio tempo in a range of plus or minus 20% from the center value, the value set in the patch.

t.n.p. (Tempo and Pitch)

Changes pitch and arpeggio tempo simultaneously, creating a special effect that resembles the changing of a tape recorder's speed. The width of the pitch change follows the change width setting selected in Pedal Effect mode's GLIDE TYPE. (The setting procedure is on p. 46.)

#1 to #32, #64 to #95,... (MIDI Control Change)

Sends control change data from MIDI OUT through the adjustment of the EXP pedal. Select any numbers from 1 to 32, or from 64 to 95. Use this when you want to operate external effects or parameters. Has no effect on internal sound generators.

- * When after selecting "L-r" or "PAn" you work the EXP pedal, you may notice a slight noise, but this does not indicate any malfunction. Furthermore, this does not change the placement of reverb or chorus.
- * You can use the "tP1", "tP2", "tP3", and "t.n.p." settings when Arpeggiator is on.
- * "Ad1", "Ad2", and "bAL", are effective if both the first and second tones are selected with LAYER (p. 34), and the 1:2 BAL is not assigned to only one of the tones.
- * When "Pit" or "t.n.p." is selected, depending on tone and range, the width of the pitch's rise may be limited.
- * The way effect is applied when "bri" or "UAH" is selected varies according to the selected tone and the "BRIGHTNESS" setting.
- * When the minimum volume setting of the EXP pedal is increased, then the effect will not be completely removed, even with the EXP pedal all the way back.

Chapter 8: The Arpeggiator Function

The GR-30 is equipped with an Arpeggiator function that is uniquely suited to guitar performances. When on, the Arpeggiator function takes over when a chord is strummed, performing complex picking (notes and rhythm).

Arpeggiator can be used to perform simple backing with synthesizer sounds as you play the melody, and can also be used to get a wide variety of effects that have never before been possible with a guitar synthesizer.

About Arpeggiator

“Arpeggio Patterns”

Let’s consider the simplest way to play an arpeggio on an actual acoustic guitar.

The left hand is used to finger the song’s chord progression. Meanwhile, the right hand is used to play with in rhythm that follows an unvarying pattern, such as string numbers 5, 4, 3, 4, 1, 3, 2, 3.

(Chord = C)

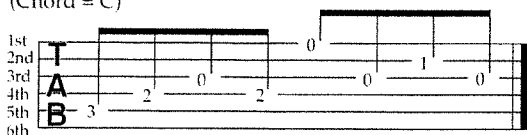

On the GR-30, this sequence of played strings (“5, 4, 3, 4...”) is called an “arpeggio pattern,” or sometimes simply “pattern.”

Every patch on the GR-30 can be given its own pattern. When Arpeggiator is on, fingering a chord (or single note) and playing one stroke causes Arpeggiator to refer to the pattern settings related to how notes are played (A-RHYTHM, A-TEMPO, and so on, which are described later), and an arpeggio is played using synth sounds.

As the figure below shows, an arpeggio pattern is an array of data arranged on grids.

The data on the grids are of three types: “play with XXX force,” “tie (hold the previous note),” and “no sound.” The horizontal length can be varied for each pattern (maximum 32).

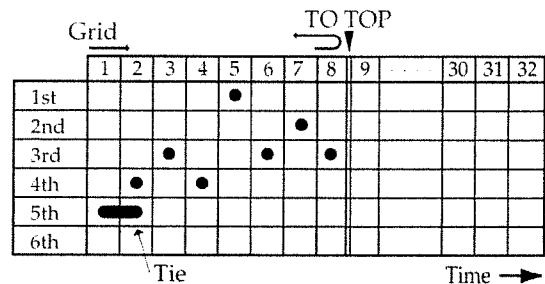

* If you play a string that is not covered by this data (such as string 6 in the example above), or if you play different number of strings from the ones covered by the data, internal rules established to ensure the most natural changes such as the chord’s lowest tone (root) are used play a substitute string and generate an arpeggio.



Arpeggiator Application Examples

Let's choose some of the preset patches (E11 through H84) to hear some actual examples of Arpeggiator's effects.

First, in the Play mode, set the PARAMETER SELECT dial to "PATCH INC/DEC BY S1/S2," use "S1" and "S2" on the GK-2A to choose a patch, and use pedal 4 to switch Arpeggiator on and off.

** When Arpeggiator is on, "ARP/HAR" in the five-point indicator lights up green. (The red light indicates a patch selected by Harmonist, and not Arpeggiator. -> p. 64).*

Reproducing Arpeggios from Guitars and Other Instruments

Patch E21 reproduces an ensemble composed of a six-string guitar and a 12-string guitar.

When a chord such as Bm or F# is fingered and all notes are strummed, Arpeggiator is activated and the notes of the 12-string guitar (on the right-hand side) are played with arpeggios. Use pedal 4 to switch Arpeggiator on and off and hear how the performance differs when Arpeggiator's effect is added and taken away.

Techno (Dance) Arpeggios

Playing a single note or chord for patch H83 plays a synth bass sound.

The rhythm automatically applied with this patch is also generated by Arpeggiator. Try switching Arpeggiator on and off with pedal 4.

With E31, plucking an open string plays a trance-techno phrase loop that combines bass and percussion sounds. You can change the pattern by varying the number of strings plucked and the position fingered with the left hand.

By using the expression pedals to change tempo and pitch (p. 49) and synchronizing the MIDI tempo to an external automatic performance system (p. 56), a patch like this that offers dance (techno) patterns can be used to develop impressive performances with unbelievable guitar sounds.

Reproducing Tremolo Effects

Patch H32 plays marimba tones.

Arpeggiator is turned off when this patch is called up, but using pedal 4 to turn it on results in marimba sounds with tremolo. In the same way, E11 reproduces a nylon-string guitar with tremolo.

Other Ways to Use Arpeggiator

Patch E14 plays percussion as backing for a sitar-type string-instrument sounds.

Arpeggiator automatically adds percussion (second tone) according to the string that is played, producing an ethnic ambience.

Also, H84 adds a delay produced by the built-in reverb to the arpeggio, and playing the appropriate chord one full stroke reproduces an Eighties-style guitar and bass ensemble.

All other preset patches include other patterns of some type, including those for which arpeggios are off and those Harmonist is selected.

Try switching Arpeggiator on and off with pedal 4 while using "PATCH INC/DEC BY S1/S2" to change patches, and listen to the different patterns. (To listen to the patterns of patches for which Harmonist is selected, follow the steps on p. 55 to switch the setting for "ARPEGGIO/harmony SEL" to "ARP" or the like.

Effective Use of the Hold Function During Arpeggios

The hold effect obtained by pressing pedal 3 while in the Pedal Effect mode can be used to bring about chord progression without stopping or breaking the rhythm marked by Arpeggiator.

When Arpeggiator is on, the effect of the Hold pedal is applied only to arpeggios, which is different from its normal behavior. This means that it can be used to hold Arpeggiator's backing pattern while plucking out the melody with other synth sounds (tones).

The GR-30 also has a latch hold that can be used to continue arpeggios even after the pedal is released (until the pedal is pressed again).

To select how the hold is applied, go into the Edit mode and set the EDIT TARGET dial to "FOOT PEDAL" and the PARAMETER SELECT dial to "C" (HOLD TYPE). You can then use [+] and [-] to change the display and choose the type of hold. (See "◆" below for descriptions of the effects obtained with various settings.)

After choosing the effect you want, set the PARAMETER SELECT dial to "WRITE PATCH?", and press [+] and [-] simultaneously to write the patch.

◆ Hold Variations Available When Arpeggiator Is On

Any of the following four can be selected when Arpeggiator is on.

- "dPr" (Damper)
- "SoS" (Sostenuto)
- "Lt.A" (Latch hold type A)
- "Lt.B" (Latch hold type B)

○ "dPr" (Damper)

Pressing the pedal and playing the guitar produces an arpeggio that is held even after the string vibration attenuates. If the strings are played again, this is reflected in the arpeggios.

Releasing the pedal ends the hold for the arpeggio. (If the string has already stopped vibrating, the arpeggio also stops.) this feature is used at times such as when you want to change how arpeggios are played without breaking the rhythm created by Arpeggiator.

<An Example of Using Hold Set to "dPr">

You can also get the interesting effect described below by steadily increasing the number of strings played while Arpeggiator is on.

1. Choose patch E31 ("dPr" is used as the hold type).
2. Go into the Pedal Effect mode and press pedal 3.
3. Play one open string to start the Arpeggiator rhythm.
4. Hold down the pedal and play another string to change the rhythm pattern of the percussion and synth bass sounds. Keep adding strings and changing positions, and listen to the results.

○ "SoS" (Sostenuto)

Pressing the pedal during guitar play while arpeggios are being produced causes the arpeggio being played at the moment the pedal was pressed to be held until the pedal is released. If a new string is played while the arpeggio is held, this new performance is not reflected in the arpeggio.

Using the "SoS" hold makes it possible to separate the first tone and second tone — the synth sound and the guitar sound — enabling you to play melodies with arpeggio backing.

<An Example of Using Hold Set to "SoS">

1. Choose patch E14 ("SoS" is used as the hold type).
2. Go into the Pedal Effect mode and strum a suitable chord.
3. While Arpeggiator is playing an ethnic percussion rhythm, press the pedal.
4. The state at the moment of pressing arpeggio (rhythm) is held. Playing the guitar during this hold lets you combine melody and chords with a sitar-type string-instrument sound. (What you play is not reflected in the arpeggios until the pedal is released.)

➤ *If you want to hold the synth sounds and arpeggios and add a guitar-sound melody to this, set the Guitar/Synth selector switch on the GK-2A to "MIX." The synth arpeggios start along with the guitar chord played at the first stroke, and pressing pedal 3 to hold this (SoS) lets you overlay play such as a guitar solo until the pedal is released.*

○ "Lt.A" (Latch hold type A)

With an ordinary hold function, pressing the pedal starts the hold, and releasing the pedal ends it. With a latch hold, however, pressing the pedal once starts the hold, and pressing the pedal again ends it. On the GR-30, a latch hold is available only when using Arpeggiator.

When "Lt.A" (Latch hold type A) has been chosen and Arpeggiator is sounded, pressing pedal 3 (HOLD) makes the GR-30 hold the arpeggio being played at the moment when the pedal was pressed. This is a latch hold, so the effect continues even if you release the pedal. The effect ends when you press the pedal again. As with "SoS," nothing you play on a new string is reflected in the effect.

During the latch hold, you can use pedal 4 "CTRL ARP/HAR" (which normally toggles arpeggios on and off) to perform chord changes for the arpeggios without disrupting the rhythm.

<An Example of Using Hold Set to "Lt.A">

1. Choose patch H82 ("Lt.A" is used as the hold type).
2. Go into the Pedal Effect mode and strum a suitable chord. This starts the arpeggios (nylon-string guitar accompaniment).
3. While Arpeggiator is playing the nylon-string guitar accompaniment, press pedal 3 (HOLD).
4. The arpeggio (accompaniment) being played at the moment the pedal was pressed is held, and continues to be held even if pedal 3 is released.
5. Nothing played on the strings during hold has any effect on Arpeggiator, so you can play a melody along with the accompaniment.
6. If you want to do a chord change, press pedal 4 (CTRL ARP/HAR) and play the new chord, then release the pedal. The chord changes without stopping the rhythm of the arpeggios being played.
7. To stop the arpeggios, press pedal 3 (HOLD) again.

➔ *Every time you press pedal 4, the unit instantly determines the string for the lowest note (the chord's root) and restructures the arpeggios.*

○ "Lt.B" (Latch hold type B)

Basic operation is the same as for "Lt.A" — the hold is maintained even if you take your foot off the pedal, and the hold is released when you press the pedal again. "Lt.B" is also like "Lt.A" in that nothing you play while the hold is in progress affects the arpeggios.

The difference with "Lt.A" lies in the behavior when the guitar is played while pedal 4 (CTRL ARP/HAR) is depressed.

With "Lt.B," the arpeggios produced by this action are the same as for "dPr." There is no restructuring of the arpeggios themselves based on the selection and number of strings played, as with "Lt.A."

<Hearing the Difference Between "Lt.A" and "Lt.B">

1. With patch H82, play a suitable chord with all strings, and apply the latch hold (Lt.A) to the arpeggios that are sounded.
2. Press pedal 4 (CTRL ARP/HAR), and while holding down the pedal, play just one or two strings on the guitar. Listen to how the arpeggios change.
3. Follow the steps on p. 53 to change the hold type to "Lt.B," then repeat steps 1 and 2 above. You can hear how the changes in the arpeggios are different from "Lt.A."

Changing the Sounding of Arpeggios

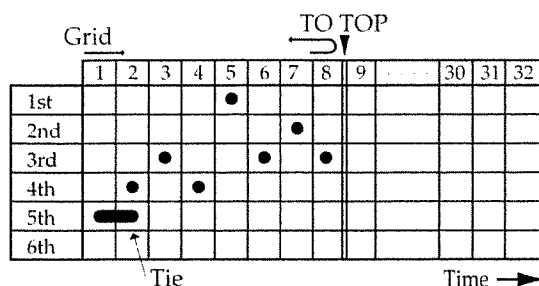

As the above figure shows, pattern information is made up only of information on the timing relationship with strings played before and after, and the force of sound generation. It does not include any information such as the length of the end of the sound, the tempo, how many notes per grid the sound is interpreted to be, or the like.

Information such as this is determined by ARPEGGIO/harmony items such as "A-RHYTHM," "A-DURATION," and "A-TEMPO." Changing these settings can create a different ambience even with the same pattern.

Turning Arpeggiator On and Off

During a performance, you can toggle arpeggios on and off by pressing pedal 4 (CTRL ARP/HAR) while in the Pedal Effect mode (or when PATCH INC/DEC BY S1/S2 has been selected while in the Play mode). You can also switch arpeggios on and off in the same way while in the Edit mode (except during the "A-TEMPO" setting, which will be described later). When Arpeggiator is turned on, the five-point indicator lights up green. (Red indicates Harmonist.) Each patch has a setting that determines whether Arpeggiator is on or off. In the Edit mode, you can save the present state (on or off) by setting the PARAMETER SELECT dial to "WRITE PATCH?" and pressing [+] and [-] at the same time. This state is then enabled the next time you call up the patch.

** If you try to change an arpeggio-related value or setting ("ARPEGGIO/harmony) SEL," "A-RHYTHM," "A-DURATION," or "A-TEMPO") for a patch with Arpeggiator off, Arpeggiator is turned on automatically to let you check the effect.*

Selecting Tones to Be Arpeggiated (ARPEGGIO SEL)

The setting "ARPEGGIO/harmony SEL" (Arpeggio/Harmony select) for each patch determines whether the first tone, the second tone, or an external sound generator is arpeggiated by Arpeggiator. Try making actual changes to this setting for the preset patches, and listen to the results.

<Verifying How ARPEGGIO SEL Works>

1. Choose patch F63 (combined brass and synth horn tones), which gives results that are clear and easy to verify.
2. Press [EDIT/PLAY] to enter the Edit mode, then set the EDIT TARGET dial to "ARPEGGIO/harmony" and the PARAMETER SELECT dial to "A" (ARPEGGIO/harmony SEL).
3. Press pedal 4 to turn on Arpeggiator for patch E63 that you've called up.
4. The display shows the current setting, "A.-2" (second-tone arpeggio). Play the guitar and make sure that the arpeggios are applied only to the second tone (synth horn).
5. Press [-] once to make the display change to show "A.-1" (first-tone arpeggio). Play the guitar — only the first tones (brass section) are arpeggiated.
6. Press [+] twice to make the display change to show "A.-b" (both: arpeggios for both tones). Play the guitar and make sure that both tones are overlaid with arpeggios.

Other values that can be chosen with [+] and [-] are as follows.

ArP

All tones (from the internal sound generator and the external MIDI sound generator) are arpeggiated.

A.-1

Only the first tone of the internal sound generator is arpeggiated.

A.-2

Only the second tone of the internal sound generator is arpeggiated.

A.-b

This "b" stands for "both," and means that the first and second tones are both arpeggiated. (The external sound generator is not arpeggiated.)

A.-E

This “E” stands for “External,” and means that only the external MIDI sound generator is arpeggiated.

A.1E

The first tone and the external MIDI sound generator are arpeggiated.

A.2E

The second tone and the external MIDI sound generator are arpeggiated.

** Settings can also be made for the values that follow these (hAr, h.-1, h.-2,..., h.2E), but choosing one of these causes Arpeggiator to stop and selects Harmonist (p. 64). Please note that if Harmonist is chosen here, it becomes impossible to select the setting items “A-RHYTHM,” “A-DURATION,” or “A-TEMPO.”*

<Overwriting the Settings for a Desired Patch>

Call up the patch you wish to change, and while still in the Edit mode, set the PARAMETER SELECT dial to “WRITE PATCH?”, and press [+] and [-] simultaneously to write the patch.

If the patch you’re changing is a preset patch from E11 to H84, or if you wish to leave the original unchanged, first set the PARAMETER SELECT dial to “WRITE TO...”, then use [+] and [-] to specify the destination patch number for the write operation.

Setting Tempo and Syncing Tempo to the External Device (A-TEMPO)

You can freely vary the tempo of the arpeggios, and save the tempo to the patch.

The setting for this is “A-TEMPO” (arpeggio tempo), which can be set to the desired tempo, and when set to “Syn.”, arpeggios can be synchronized to the tempo of an external MIDI device, such as a sequencer. Let’s try making some actual changes to preset patch settings and listening to how the tempo changes.

<Verifying How A-TEMPO Works>

1. Choose patch E21 (acoustic guitar arpeggios).
2. Press [EDIT/PLAY] to enter the Edit mode, then set the EDIT TARGET dial to “ARPEGGIO/harmony” and the PARAMETER SELECT dial to “D” (A-TEMPO).
3. The current value of 78 is displayed. (This value is in bpm, or beats per minute). The [+] and [-] keys can be used to change the display range of “Syn.”, 50, 51, 52,..., 250, so play the guitar and listen to how the arpeggio tempo changes.

➔ *By setting A-TEMPO to “Syn.” and connecting the MIDI OUT connector on an external MIDI sequencer (such as the Roland MC-303) to MIDI IN on the GR-30, you can synchronize the arpeggios to the performance tempo of the external device.*

** If you don’t get synchronized arpeggios, check whether the external device is set up to send MIDI clock message. If set to “Syn.”, no arpeggios are played on just the GR-30.*

<Overwriting A-TEMPO for a Desired Patch>

Call up the patch you wish to change, and while still in the Edit mode, set the PARAMETER SELECT dial to “WRITE PATCH?”, and press [+] and [-] simultaneously to write the patch.

If the patch you’re changing is a preset patch from E11 to H84, or if you wish to leave the original unchanged, first set the PARAMETER SELECT dial to “WRITE TO...”, then use [+] and [-] to specify the destination patch number for the write operation.

Tap Tempo

Pedal 4 is normally used to turn arpeggios on and off when the EDIT TARGET dial has been set to "ARPEGGIO/harmony" and settings for arpeggio-related items are made.

As an exception to this, however, pedal 4 can be used when making tempo settings with what's called Tap Tempo, a function that lets you set or change tempo by tapping out a rhythm with your foot.

When the PARAMETER SELECT dial is set to "D" (A-TEMPO) and the tempo is displayed, tap pedal 4 several times at the desired tempo. The message "tAp" appears on the display, then the display and the tempo both change.

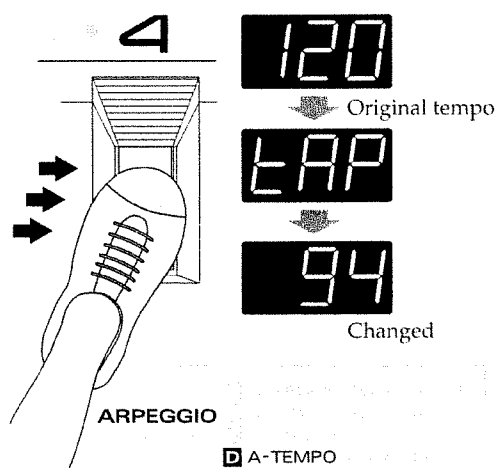

Tap Tempo can also be used as described below.

- In the Pedal Effect mode...
Press the "Bank Up" side of an external bank shift pedal several times (only when Arpeggiator is on).
- During realtime recording of arpeggio patterns...
Press pedal 4 several times.

In either case, the changed tempo is a patch setting, so it can be saved to the patch while in the Edit mode by setting the PARAMETER SELECT dial to "WRITE PATCH?", then pressing [+] and [-] simultaneously to execute a patch write.

- ➔ Tap Tempo can also be activated using the BANK SHIFT pedal (Up side) in the Pedal Effect mode.

* Some preset patches, such as E11, set the value of A-TEMPO to a multiple of the actual tempo in order to achieve a fine tremolo. This special setting means that the interpretation of the tempo may be somewhat unnatural with the Tap Tempo or when syncing to an external device.

Adjusting Sound Length (A-DURATION)

When reading a pattern, the setting that determines whether the sound is short and staccato or more tenuto is "A-DURATION" (arpeggio duration). Let's try making some actual changes to preset patch settings and listening to how the tempo changes.

<Verifying How A-DURATION Works>

1. Choose patch H83 (synth bass with a quick rhythm), which gives results that are clear and easy to verify.
2. To maximum the effect of change in A-DURATION, hold down [EDIT/PLAY] and press [+] to turn off the built-in effects processor. (This makes the "EFFECT BYPASS" light come on.)
3. Press [EDIT/PLAY] to enter the Edit mode, then set the EDIT TARGET dial to "ARPEGGIO/harmony" and the PARAMETER SELECT dial to "C" (A-DURATION).
4. The current value of 60 is displayed. Play the guitar and listen to how the sound is clipped.
5. The display changes every time [-] is pressed, cycling to 50, to 40, and to 30 (minimum). Play the guitar at each setting and notice how the notes become increasingly staccato.
6. The display changes in the opposite direction when [+] is pressed, cycling to 70, 80, 90, 100, 120, and FuL (full). Try playing the guitar at each setting, and notice how the notes grow more tenuto.

The range that can be selected using [+] and [-] is "30, 40, 50, 60, 70, 80, 90, 100, 120, FuL (full)." The value shown in the display is a percentage.

When "30" is selected, for example, the notes on the grid in the figure are extremely staccato — only 30% of their full values. Also, when FuL (full) has been selected, a note does not stop being sounded until the same string is played again, even when adjacent notes on the grid are not linked by ties. (Tones for instruments that attenuate, such as the piano, attenuate naturally.)



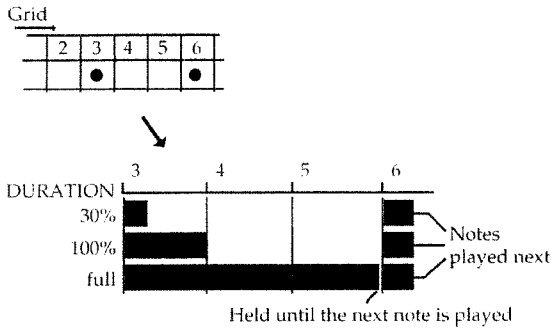

<Overwriting A-DURATION for a Desired Patch>

Call up the patch you wish to change, and while still in the Edit mode, set the PARAMETER SELECT dial to "WRITE PATCH?", and press [+] and [-] simultaneously to write the patch. If the patch you're changing is a preset patch from E11 to H84, or if you wish to leave the original unchanged, first set the PARAMETER SELECT dial to "WRITE TO...", then use [+] and [-] to specify the destination patch number for the write operation.

Selecting Notes and Rhythm (A-RHYTHM)

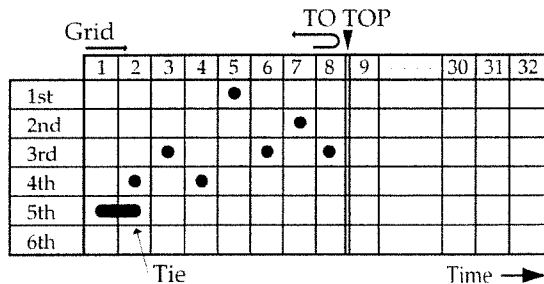

"A-RHYTHM" (arpeggio rhythm) is the item which determines which kind of notes to interpret the "Single Grid" on the above figure to be for creating arpeggios.

This setting can even make settings for heavy and light shuffle beats, making it possible to create arpeggios with different ambience from a single pattern.

<Verifying How A-RHYTHM Works>

1. Choose patch H83 (synth bass with a quick rhythm), which gives results that are clear and easy to verify.

2. Press [EDIT/PLAY] to enter the Edit mode, then set the EDIT TARGET dial to "ARPEGGIO/harmony" and the PARAMETER SELECT dial to "B" (A-RHYTHM).
3. The current value of "16._" (one grid mark = one sixteenth note) is displayed. Play the guitar and listen to the arpeggio rhythm that is actually sounded.
4. While in this state, press [-] four times, making the display change to read "08._" (one grid mark = one eighth note). Play the guitar to hear how the rhythm has changed.
5. Then press [+] twice to make the display change to read "08.H" (eighth notes with a heavy shuffle). Play the guitar forcefully and hear how the rhythm has changed to one with a shuffle.

The complete selection of values that can be chosen with [+] and [-] is as follows.

- 04._ Quarter notes (one grid mark = one beat)
- 08._ Eighth notes (two grid marks = one beat)
- 08.L Eighth notes with light shuffle (two grid marks = one beat, light shuffle)
- 08.H Eighth notes with heavy shuffle (two grid marks = one beat, heavy shuffle)
- 08.t Triplet eighth notes (three grid marks = one beat)
- 16._ Sixteenth notes (four grid marks = one beat)
- 16.L Sixteenth notes with light shuffle (four grid marks = one beat, light shuffle)
- 16.H Sixteenth notes with heavy shuffle (four grid marks = one beat, heavy shuffle)
- 16.t Triplet sixteenth notes (six grid marks = one beat)

<Overwriting A-RHYTHM for a Desired Patch>

Call up the patch you wish to change, and while still in the Edit mode, set the PARAMETER SELECT dial to "WRITE PATCH?", and press [+] and [-] simultaneously to write the patch.

If the patch you're changing is a preset patch from E11 to H84, or if you wish to leave the original unchanged, first set the PARAMETER SELECT dial to "WRITE TO...", then use [+] and [-] to specify the destination patch number for the write operation.

Copying Other Patch Arpeggio Patterns

The steps explained below can be used to copy arpeggio patterns from one patch to another.

Since all preset patches come with arpeggio patterns, this means you have a total of 128 types to choose from and copy to your own original patches.

You can also use the same methods to copy patterns from any other patches you may have made with your own original patterns (p. 60).

<Copying Arpeggio Patterns from Another Patch>

1. Choose the target patch (the patch that you wish to copy to).
2. Press [EDIT/PLAY] to enter the Edit mode, and set the EDIT TARGET dial to "ARPEGGIO/harmony."
3. Set the PARAMETER SELECT dial to "A" (A-ARPEGGIO/harmony SEL) and check whether the tone specified as the arpeggio target is first or second (or both). It will be possible to test-play the pattern unless the tone selected by TONE MIX "LAYER" (p. 34) is specified, so make the setting accordingly.
4. Make sure the PARAMETER SELECT dial is set to one of the four positions from "A" to "D" (the arpeggio-related items), and press pedal 2. The message "CPy" (copy) appears on the display, and the pattern copy function is called up.
5. Use [+] and [-] to change the display to show the patch number (the final period will flash).
6. The pattern for the patch indicated by the displayed number is immediately developed for the patch selected in step 1. While playing the guitar to check the arpeggios that are generated, use [+] and [-] to find a pattern that matches the tone.
7. Press pedal 1 to end the pattern copy function.
8. If you also wish to write the patch, then while still in the Edit mode, set the PARAMETER SELECT dial to "WRITE PATCH?", and press [+] and [-] simultaneously to write the patch. If the patch you're changing is a preset patch from E11 to H84, or if you wish to leave the original unchanged, first set the PARAMETER SELECT dial to "WRITE TO...", then use [+] and [-] to specify the destination patch number for the write operation.

** When a pattern is copied, the "A-RHYTHM," "A-DURATION," and "A-TEMPO" settings of the original patch are also automatically copied.*

** Arpeggiator is turned on automatically if you try to copy a pattern for a patch which has Arpeggiator off. If necessary turn it back off before performing a write operation. (Set the EDIT TARGET dial to "ARPEGGIO/harmony SEL" and the PARAMETER SELECT dial to "A," "B," or "C," and press pedal 4.)*

Creating an Arpeggio Pattern

A number of arpeggio patterns equal to the number of preset patches is available (128), but it's also possible to create new patterns for different tunes and purposes.

The steps for creating a new patch are similar to the steps used for recording with a MIDI sequencer, but note that the information stored is the sequence of strings played, and so there are also some unique operations.

Programming One Note at a Time: The "Step" Method

The procedure used to input the string sequence for an arpeggio by playing the strings while watching the grid number display is called the "step" method.

Pedals 1 through 4 can also be used to add ties and rests to the pattern. Step input is a method that involves inputting each item of data on the grid one by one, and so regular patterns of continuous notes of the same lengths can be made.

In the example shown here, we'll use step input to make a new arpeggio pattern for patch H83. We'll make the pattern shown in the figure.

Grid	1	2	3	4	5	6	7	8	9	10	11	12	13	14	15	16
1st																
2nd			•			•••		•								•••
3rd			•			•••		•				•••				
4th	•••	•	•		•••	•	•	•••	•	•	•••	•	•	•••	•	•
5th																
6th																

As you can see from the example, the fourth string is used apart from the others to make an independent rhythm. With the step method, the strings can be separated into groups or cycles for input. Here we'll divide these four strings into groups of one to three strings, and input two cycles.

► *The force with which strings are played during input is reflected in the level and force of the arpeggio notes, and is reproduced.*

<An Example of Step Input>

1. After calling up H83, press [EDIT/PLAY] to enter the Edit mode.
2. Set the EDIT TARGET dial to "ARPEGGIO/harmony" and the PARAMETER SELECT dial to "A" or "B."

3. Press pedal 1 (BEGIN) to make the display changes to "toP" (top) and start step input. (If "C" or "D" had been selected in step 2, this action would start the realtime input function, which will be described later.)

Here's how the pedals work during step input:

Pedal 1 (BEGIN/END)

Press this pedal again to end step input.

Pedal 2 (TIE)

This inputs a tie on the grid, continuing the note of the previous grid mark.

Pedal 3 (REST)

This inputs a rest on the grid.

Pedal 4 (TO TOP)

This causes the current grid mark to become the end of the pattern, and returns the grid input next to the top. (This is used when performing step input for separate strings for two or more cycles. The determination of the end of the pattern is valid only the first time this pedal is pressed.)

(VALUE) [-]

If you play the wrong string or press the wrong pedal, press this to erase the latest operation and back up by one.

4. We'll start with the input for string 4. Pluck string 4 once and stop it immediately. This causes "G.01" to appear on the display, which shows that the information "sound string 4" has been input to the first grid mark.
5. Press pedal 2 (TIE) once to advance to "G02" and connect the notes. Internally, the staccato rhythm changes to a longer one.
6. Pluck string 4 twice and stop it immediately to advance to "G04" (this inputs a "bah-dada" rhythm).

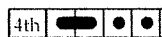

7. Repeat steps 4 through 6 three more times to make the display advance to "G.16" and end the input for string 4.



6. When you've finished playing, press pedal 1 (END) to stop the metronome and return to the normal Edit mode.
7. Stroke a chord once to check the results. If necessary, adjust the settings for A-RHYTHM, A-TEMPO, and A-DURATION that you made in step 2 to obtain the desired values.
8. The arpeggio pattern is part of the patch, so to save it, go into the Edit mode, set the PARAMETER SELECT dial to "WRITE PATCH?", and press [+] and [-] simultaneously to write the patch.

* After advancing to the grid location specified in step 4, the unit returns to the top (G.01). String-by-string input over a number of cycles is also possible. Please not that unlike real-time loop recording with a sequencer or the like, the sounds corresponding to a pattern that has already been input cannot be played back during recording of a later cycle. (Overwriting the data for a string erases any data input in a previous cycle.)

* Input using the real-time method can be made only with the timing of the metronome's clicking. Unlike a sequencer or similar equipment, data cannot be input between clicks.

* The arpeggio pattern cannot be only partially modified.

➔ In steps 3 and 4 and when setting A-TEMPO, you can also set the tempo automatically by pressing pedal 4 at the desired tempo (Tap Tempo → p. 57).

Inputting with a Computer or Sequencer

If you have a MIDI sequencer (including computer sequencer software) that you're more familiar with using, you can create arpeggios as sequence data on the sequencer and import this data to the GR-30.

This is done by synchronizing the GR-30 to the tempo of the sending sequencer and performing real-time input.

<Creating Patterns with a Sequencer>

1. Record a fingered arpeggio on the GR-30 for one or two bars from the start of the sequencer. Perform recording on six channels (for six strings) with transmitting in mono mode (see "Using the GR-30 as an Input Tool for an External Sequencer" on p. 77).

As you do this, don't forget that the GR-30 cannot play back notes with timing information more exact than the metronome's clicks. Also, be sure that the number of measures doesn't exceed Arpeggiator's limit for pattern length.

* You may also use a step recording function or the like on the sequencer to create the data without using the GR-30. Input the note information on the six channels starting with the MIDI "CHANNEL" setting (p. 71; when shipped from the factory, these are channels 11 through 16) as the string-playing information for strings 1 through 6. Three types of information are reflected when developing the pattern: the note's channel (string), the note's length, and the note's MIDI velocity. The note number has no particular meaning.

2. Insert a blank measure of four beats at the start of the finished sequence data. (This serves as a blank for counting down by Arpeggiator.)
3. Use a MIDI cable to connect the MIDI OUT connector on the sequencer to the GR-30's MIDI IN connector, then press [EDIT/PLAY] on the GR-30 to enter the Edit mode.
4. Set the EDIT TARGET dial to "ARPEGGIO/harmony" and the PARAMETER SELECT dial to "B" (A-RHYTHM), and use [+] and [-] to make the setting that matches the notes in the pattern being created. For instance, if the pattern is composed of eighth notes, set this to "08_.".
5. Set the PARAMETER SELECT dial to "D" (A-TEMPO), then use [+] and [-] to select the lowest value ("Syn.") and synchronize the GR-30 to the tempo of the external MIDI device.
6. Press pedal 1 (BEGIN) while the PARAMETER SELECT dial is set to "C" or "D" to enter real-time input and start the ticking of the metronome ("tock, tock, tock, tock..."). If the last grid-mark number (pattern length) reads something like "G.16", press [+] and [-] to change this to match the pattern length set for the sequencer.
7. Start playback from the sequencer from the top. After counting down, input begins. When you've input the specified number of bars and stopped the sequencer (or pressed pedal 1), the GR-30 also stops the metronome sound and ends the real-time input function.
8. Stroke a chord once to check the results. If necessary, adjust the settings for A-RHYTHM, A-TEMPO, and A-DURATION that you made in step 2 to obtain the desired values.

-
9. The arpeggio pattern is part of the patch, so to save it, go into the Edit mode, set the PARAMETER SELECT dial to "WRITE PATCH?", and press [+] and [-] simultaneously to write the patch.

What to do If You Have Difficulty Producing Patterns

- * *If the grid numbers don't advance as expected during step input, you may have played the sound for a grid mark before the string for the previous grid mark stopped. If two strings are played in combination, Arpeggiator interprets them as chord input. The unit advances to the next grid number when the current string stops, so care is needed to differentiate between single notes and chords as you play.*
- * *If data is not placed at the desired grid mark during real-time input, try inputting the data with the tempo greatly slowed down. Also, if the sound is prolonged the way you want, vary the A-DURATION setting to 100, 120, FuL (full), or the like, and listen to the results.*
- * *If you have recorded an arpeggio phrase on an external sequencer and wish to use MIDI to export this as a GR-30 pattern, make sure that the note information is arranged correctly in the original data. If the data contains unwanted note information due to picking noise or the like (such as extremely short note length), remove it from the data before you export it.*

Chapter 9: Adding Harmonies in a Specific Key (The Synth Harmonist)

The GR-30 lets you use the “TRANS 1ST (2ND)” setting (p. 34) to shift the pitch of the first and second tones in parallel to the guitar notes, creating a harmony effect.

However, if you want to obtain harmonies that are more musical, it’s necessary to vary the differences in pitch between two parts according to the key of the song and the scale being played.

This is achieved by the GR-30’s Synth Harmonist function, also known as “Harmonist.”

By setting the key of the melody being played to a patch, you can create beautiful harmonies by adding synth sounds to guitar sounds (or to other synth sounds).

About the Harmonist

Let’s take a look at how Harmonist is put together, and compare it with the Transpose function.

The sample score shown below compares the effects of the Transpose function and Harmonist when playing the scale in the key of C.

The image shows two musical staves. The top staff is labeled 'Transpose' and shows a scale in the key of C. A 'Normal note' is marked at the first position (C4), and a 'Transposed note' is marked at the second position (D4). The bottom staff is labeled 'Harmonist' and shows the same scale. A 'Normal note' is marked at the first position (C4), and a 'Harmony note' is marked at the second position (D4). Arrows point from the 'Normal note' in the top staff to the 'Normal note' in the bottom staff, and from the 'Transposed note' in the top staff to the 'Harmony note' in the bottom staff, illustrating that the Harmonist function maintains a consistent interval between the main note and the harmony note, unlike the Transpose function which shifts the entire scale.

The differences in the results of these two methods are shown by the arrows in the figure.

The harmonies produced are by parallel transposition may feel unnatural. The position on the scale where this problem occurs depends on the key, whether the key is major or minor, the interval between the main melodic line and the harmony, and so on.

The GR-30’s Harmonist uses information such as the key that is already set for a patch to adjust the interval between the guitar sound and synth sound (or between first and second tones), creating melodious harmonies.

The GR-30’s Harmonist also fully supports chord play. This means that complex chords can be created just by playing a simple three-note chord, greatly reducing the chances of fingering mistakes during rough performances with no muting.

The GR-30’s Harmonist lets you make settings for the following four items.

ON/OFF

This toggles Harmonist on and off (p. 65, selected with pedal 4).

“harmony SEL” (Harmony Select, p. 66)

This sets which tone is the harmony.

“h-style” (Harmony Style, p. 66)

This sets the interval between the main melodic line and the harmony.

“h-key” (Harmony Key, p. 68)

This sets the key and the major or minor aspect of the melody that is played.

“h-remote” (Harmony Remote, p. 69)

This allows the function of the key-setting using an external MIDI pedal to be toggled on and off.

What You Can Do with the Harmonist

Adding Synth Sounds to Guitar Sounds

The commercially available effecter known as “Harmonist” is a type of pitch shifter, and can make harmonies for guitar sounds only with guitar sounds. In contrast to this, the GR-30 Synth Harmonist lets you take the guitar sounds you normally use and make harmonies with any sounds you like.

These can be put to practical use, such as by adding a marimba harmony to a clean guitar sound to produce an understated harmony, or adding a rock organ to a distortion guitar to create a minor-key harmony.

And of course, you can always select a guitar tone on the GR-30 to create pure guitar harmonies.

If you wish to create a harmony with a guitar sound and the GR-30's sound, set the guitar/synth selector switch on the GK-2A to “MIX.”

** To make all synth sounds selected with patches (from both the first and second tones to the external MIDI sound generator) a harmony part in combination with the guitar sound, follow the steps of p. 66 to set “ARPEGGIO/harmony SEL” to “hAr.”*

Creating Harmonies with Two Synth Sounds

You can make harmonies using only synth sounds and without playing the guitar by setting the guitar/synth selector switch on the GK-2A to “SYNTH.”

Let's call up patch E12, for which Harmonist is on. In this example, the first tone (distortion guitar + bass guitar) is the main melodic line, and the second tone (distortion guitar with feedback) is the harmony.

Play a melody in C major and hear the “fat” guitar orchestration composed exclusively of synthesizer sounds.

Also, patch F42 is an example of using Harmonist to create character for an instrument, and realistically reproduces the ambience of an accordion. This patch produces the same C-major third harmony as E12 above, but the disparate sounds make for a completely different effect.

These examples use fairly similar sounds to create the harmonies, but it can also be quite effective to create harmonies with totally different tones (such as sax and muted trumpet), and use COMMON “PAN” (p. 39) to assign these to the left and right stereo positions. Naturally, you can also combine guitar sounds to the main melodic line by setting the switch on the GK-2A to “MIX.”

Operation

Turning the Harmonist On and Off

During a performance, you can toggle Harmonist on and off by pressing pedal 4 (ARP/HAR CTRL) while in the Pedal Effect mode (or when PATCH INC/DEC BY S1/S2 has been selected while in the Play mode).

You can also switch Harmonist on and off in the same way when the EDIT TARGET dial has been set to “ARPEGGIO/harmony” while in the Edit mode. Each patch has a setting that determines whether Harmonist is on or off.

In the Edit mode, you can save the present state (on or off) by setting the PARAMETER SELECT dial to “WRITE PATCH?” and pressing [+] and [-] at the same time. This state is then enabled the next time you call up the patch.

(For many preset patches, Arpeggiator is selected instead of Harmonist. To use Harmonist with a patch for which Arpeggiator is selected, follow the steps in the next section to set “ARPEGGIO/harmony SEL” to “h-2” or the like.)

When Harmonist is turned on, “ARP/HAR” on the five-point indicator lights up red. (Green indicates Arpeggiator.)

** If you try to change related value or setting (“ARPEGGIO/harmony SEL,” “h-style,” “h-key,” or “h-remote”) for a patch with Harmonist off, Harmonist is turned on automatically to let you check the effect.*

Selecting Harmony Tones (harmony SEL)

The setting "ARPEGGIO/harmony SEL" (Arpeggio/Harmony select) for each patch determines whether the first tone, the second tone, or an external sound generator becomes the harmony. Try making actual changes to this setting for the preset patches, and listen to the results.

<Verifying How harmony SEL Works>

1. Choose patch F53 (combined distortion guitar and tenor sax tones).
2. Press [EDIT/PLAY] to enter the Edit mode, then set the EDIT TARGET dial to "ARPEGGIO/harmony" and the PARAMETER SELECT dial to "A" (ARPEGGIO/harmony SEL).
3. Press pedal 4 to turn on Harmonist for patch F53 that you've called up.
4. The display shows the current setting, "h.-1" (first tone is harmony). Play the guitar and make sure that the play a melody in G major and check the harmony.
5. Press [+] once to make the display change to show "h.-2" (second tone is harmony). Play the guitar — notice how the melody and harmony tones in step 4 have been exchanged.
6. Press [+] once again to make the display change to show "h.-b" (both: both tones are harmony). Set the GK-2A switch to "MIX" and play along with the guitar sound, and hear how the sounds from the GR-30 become the harmony for the guitar sound (melody).

Other values for Harmonist that can be chosen with [+] and [-] are as follows.

hAr

All tones (from the internal sound generator and the external MIDI sound generator) become the harmony.

h.-1

The first tone of the internal sound generator becomes the harmony.

h.-2

The second tone of the internal sound generator becomes the harmony.

h.-b

This "b" stands for "both," and means that the first and second tones both become the harmony. (The external sound generator does not become the harmony.)

h.-E

This "E" stands for "External," and means that only the external MIDI sound generator becomes the harmony.

h.1E

The first tone and the external MIDI sound generator become the harmony.

h.2E

The second tone and the external MIDI sound generator become the harmony.

** Settings can also be made for the values that precede these (ArP, A.-1, A.-2, ..., A.2E), but choosing one of these causes Harmonist to stop and selects Arpeggiator (p. 51). Please note that if Arpeggiator is chosen here, it becomes impossible to select the setting items "h-style," "h-key," or "h-remote."*

<Overwriting the Settings for a Desired Patch>

Call up the patch you wish to change, and while still in the Edit mode, set the PARAMETER SELECT dial to "WRITE PATCH?", and press [+] and [-] simultaneously to write the patch.

If the patch you're changing is a preset patch from E11 to H84, or if you wish to leave the original unchanged, first set the PARAMETER SELECT dial to "WRITE TO...", then use [+] and [-] to specify the destination patch number for the write operation.

Setting Harmonic Intervals (h-style)

The interval between the melody and harmony that Harmonist uses (a third, a fifth, or the like) is set with the ARPEGGIO/harmony item "h-style" (harmony style).

<An Example of How to Change h-style>

1. Use "ARPEGGIO/harmony SEL" to call up a patch for which Harmonist is selected, and press [EDIT/PLAY] to go into the Edit mode.
2. Set the EDIT TARGET dial to "ARPEGGIO/harmony" and the PARAMETER SELECT dial to "B" (h-style).
3. The display shows the currently selected interval (-7, -6, -5, -4, -3, -2, 2, 3, 4, 5, 6, 7, or diM).

4. Use [+] and [-] to select the desired interval, turn the PARAMETER SELECT dial to "WRITE PATCH?", and press [+] and [-] simultaneously to write the patch.

➔ To save to another patch number, then before step 4, turn the PARAMETER SELECT dial to "WRITE TO...", and use the [+] and [-] buttons to designate a patch number as the destination.

The various setting produce the following intervals between the melody and the harmony.

Key = C



h-style	tonic	b2nd	2nd	b3rd	3rd	4th	b5th	5th	#5th	6th	b7th	7th
dim	3	3	3	3	3	3	3	3	3	3	3	3
+ 7th	11	10	10	9	10	11	10	10	9	10	9	10
+ 6th	9	9	9	8	8	9	8	9	8	8	8	8
+ 5th	7	6	7	6	7	7	6	7	6	7	6	6
+ 4th	5	5	5	5	5	6	5	5	5	5	5	5
+ 3rd	4	3	3	3	3	4	3	4	3	3	3	3
+ 2nd	2	2	2	2	2	2	2	2	2	2	2	2
- 2nd	-1	-2	-2	-3	-2	-1	-2	-2	-3	-2	-3	-2
- 3rd	-3	-3	-3	-4	-4	-3	-4	-3	-4	-4	-4	-4
- 4th	-5	-6	-5	-6	-5	-5	-6	-5	-6	-5	-6	-6
- 5th	-7	-7	-7	-7	-7	-7	-7	-7	-7	-7	-7	-7
- 6th	-8	-9	-9	-9	-9	-8	-9	-8	-9	-9	-9	-9
- 7th	-10	-10	-10	-10	-10	-10	-10	-10	-10	-10	-10	-10
* minor +3rd	3	3	3	4	3	3	3	4	4	3	4	3

(Unit: semitone)

* When h-style is "+3," and h-key is set to "minor," the harmony is made in a minor scale.

* The setting "diM" stands for "diminished," and produces a harmony that is always a diminished third (three semitones) from the melody, regardless of the "h-key" setting. This is effective when playing in a diminished scale.

Setting Transpose and "h-style"

Transpose settings include the TONE MIX "TRANS 1st" and "TRANS 2ND" items, as well as MIDI "TRANPOSE." Each of these is separate from "h-style," the Harmonist setting for the interval, and each produces an independent effect.

This means that when using Harmonist, Transpose for the tone (or external sound generator) to be used as the harmony should normally be set to "0."

However, it is probably no problem to use Transpose to shift the melody or harmony for Harmonist by octaves.

<An Example: Transposing the Melody Down an Octave>

1. Set "ARPEGGIO/harmony SEL" so that both the first and second tones become the harmony (p. 66).
2. Of the first and second tones, set "TRANS 1ST (2ND)" for the tone that serves as the melodic line to "-12".
3. Set the GK-2A selector switch to "MIX" to combine the guitar's sounds.

This produces a fat sound that sandwiches the guitar sound with a synth sound transposed down an octave and a synth harmony one third higher.

* The values for Transpose (TONE MIX "TRANS 1st" and "TRANS 2ND" and MIDI "TRANPOSE" — -36 to 0 to 24) are displayed in semitones (one octave = 12). In contrast to this, however, the Harmonist "h-style" values (-7 to 0 to 7, and diM) are displayed in intervals (third, fifth, and so on). Take care not to get these mixed up.



Setting the Key (h-key)

The "ARPEGGIO/harmony" setting which is used to make the patch setting for key of the melody played, such as C or Gm (G minor), is "h-key" (harmony key).

<An Example of Changing h-key>

1. Use "ARPEGGIO/harmony SEL" to call up a patch for which Harmonist is selected, and press [EDIT/PLAY] to enter the Edit mode.
2. Set the EDIT TARGET dial to "ARPEGGIO/harmony" and the PARAMETER SELECT dial to "C" (h-key).
3. The current setting is shown on the display (C, G#, E-, and so on; for details, see ♦ below).
4. Use [+] and [-] to choose the desired key, then turn the PARAMETER SELECT dial to "WRITE PATCH?", and press [+] and [-] simultaneously to write the patch.

➔ To save to another patch number, then before step 4, turn the PARAMETER SELECT dial to "WRITE TO...", and use the [+] and [-] buttons to designate a patch number as the destination.

♦ Settings available in step 3 and examples of how they appear on the display are shown below.

C, C#, Eb (D#), E, F, F#, G, Ab (G#), A, Bb (A#), and B
Cm, C#m, Ebm (D#m), Em, Fm, F#m, Gm, Abm,
(G#m), Am, Bbm (A#m), and Bm

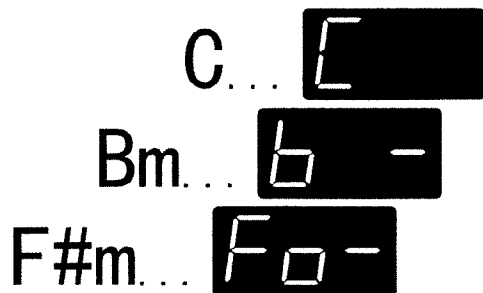

* If "diM" has been selected for the "h-style" setting described earlier, the harmony remains the same no matter what "h-key" setting is used. (The harmony is fixed at a diminished third above the melody.)

<About the Key Display>

The key set for a patch for which Harmonist is on can be checked without examining "h-key" in the Edit mode. What follows are two methods for displaying a key to be checked.

- In the pedal Effect mode...
The key is displayed approximately once every four seconds, between the "PdL" displays.
- When "PATCH INC/DEC BY S1/S2" has been selected while in the Play mode...
The key is displayed approximately once every four seconds, between the displays of the patch number.

However, when "h-style" is set to "diM" (diminished), this is indicated by displaying "diM" instead of the key (h-key setting).

Changing the Key from External Pedal or Other Device with MIDI Note Messages (h-remote)

The Harmonist key (h-key) can be changed at any time during a performance by sending MIDI note message to the GR-30 from an external MIDI device (such as optional FC-200 MIDI foot controller or PK-5 MIDI pedal keyboard).

The setting item that determines whether this function is on or off for each of the patches is ARPEGGIO/harmony "h-remote" (harmony key remote).

<Changing the Harmonist Key with an External MIDI Pedal>

1. Use a MIDI cable to connect the MIDI OUT connector on a MIDI keyboard, FC-200, or the like to the GR-30's MIDI IN connector.
2. Set the MIDI send channel on the external device to the same MIDI channel as the GR-30 (p. 71).
3. Call up the patch for which you wish to use the remote key function, and press [EDIT/PLAY] to enter the Edit mode.
4. Set the EDIT TARGET dial to "ARPEGGIO/harmony" and the PARAMETER SELECT dial to "D" (h-remote).
5. The display shows the current setting: "on" means the remote function is on, and "off" means it is off.
6. Press [+] to switch on the function, then turn the PARAMETER SELECT dial to "WRITE PATCH?", and press [+] and [-] simultaneously to write the patch.
7. Refer to the owner's manual for the external device, and send MIDI note message to the GR-30. (If you're using the FC-200, press the "MODE" button on the pedal to switch to the Note mode.) No matter what mode the GR-30 may be in, it receives this information and switches "h-key" to the note specified by the Note message (C#, b, G...).

When "PATCH INC/DEC BY S1/S2" has been selected while in the Play mode, or when in the Pedal Effect mode, the change in key can be confirmed by checking the display.

- * The Harmonist remote function has no effect with a patch for which Harmonist has not been selected by ARPEGGIO/harmony, even if "h-remote" is on.
- * When "h-remote" is on, the GR-30's internal sound generator does not produce sounds according to MIDI Note message. (Such Note message is interpreted as instructions for changing key, not for playing sounds.) For this reason, "h-remote" should be left off when not needed.

Switching Between Major and Minor During a Performance

In the Pedal Effect mode (p. 22), pressing the "Up" side of an external BANK SHIFT pedal changes the patch's "h-key" setting (p. 68) from major to minor or vice versa (for example, C# → C#m → C# → C#m...).

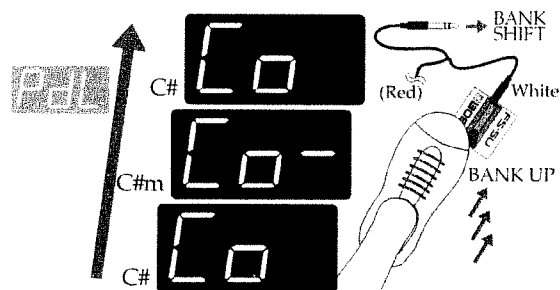

On some patches, the selected "h-style" setting may be "diM" (diminished: harmony is fixed at a diminished third above the melody, regardless of the "h-key" setting). In such cases, the operation just described doesn't toggle "h-key" between major and minor key, but instead toggles "h-style" between "diM" and "3." As a result, this toggles between diminished and major (or minor) key.

(Example: diM → F → diM → F..., or diM → Gm → diM → Gm..., and so on)

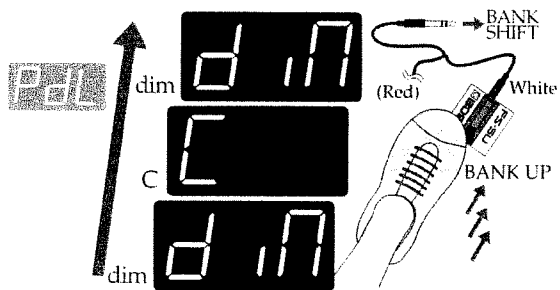

- * To ensure reproducibility of a performance when the GR-30 and a sequencer are combined, especially when using a loop connection as shown on p. 78, the state of toggling between major and minor is sent to the external device from MIDI OUT. (This is done using MIDI message called a MIDI System Exclusive (SysEx) message which can be interpreted only by equipment specified by the data itself.)

Chapter 10: Connecting to External Sound Generators and Sequencers

Connecting an external sound generator to the GR-30 makes it possible to play sounds not included the 384 built-in tones, and to create fatter sounds by combining notes from the GR-30 and the external device. The GR-30 can also serve as a convenient input tool for a MIDI sequencer (a device for recording performances). This chapter explains how to make such steps using external devices (and how to use MIDI functions).

About MIDI

MIDI stands for “Musical Instrument Digital Interface,” a worldwide standard that enables electronic instruments and peripherals to share information about performances, sound switching, and other functions.

MIDI is a standard that is shared by a wide range of instruments from different manufacturers. For instance, you could use a MIDI controller from company A to play a sound module from company B or send data to a sequencer from company C.

MIDI connectors (IN and OUT) are a standard feature of the GR-30. With MIDI, you can use the guitar to control external sound generators (such as synthesizers and samplers), or play the music you want to input into a MIDI sequencer. Also, as we’ve already seen on p. 31, you can send data such as patch data to other equipment for performance or storage.

What follows is a list of some of the different types of MIDI messages that the GR-30 can handle.

- Note On messages provide information on what string was played, and its pitch and force.
- Note Off messages provide information on when a string stops vibrating.
- Bend messages provide information for changing the pitch smoothly, such as when bending, sliding, or hammering.
- Program Change messages transmit commands for switching patches.
- Control Change messages provide information on changes in volume and effects.
- System Exclusive (SysEx) messages provide information for exchanging patch data with external instruments.

MIDI

Controlling an External MIDI Sound Device

Connecting to an External MIDI Sound Device

Follow the figure below to connect the GR-30 to an external MIDI sound device.

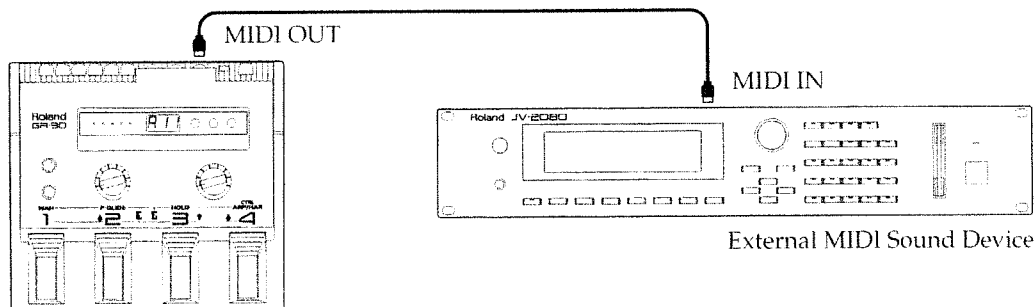

The Flow of a MIDI Messages, and Necessary Settings (CHANNEL, BEND RANGE)

Once you've made the connections, make the required settings on the GR-30.

○ MIDI Channel (MIDI "CHANNEL")

When exchanging MIDI performance message with an external device, the GR-30 and the external device must be set to the same MIDI channel.

MIDI channels range from 1 to 16, and on the GR-30 you can choose to use one channel per string, for a total of six channels, or to exchange information for all six strings on a single channel (Mono mode and Poly mode -> For details, see the next page, p. 72). Follow the steps described later to make the MIDI "CHANNEL" setting.

** When using the GR-30 in combination with a multitimbral sound module (a sound generator offering a number of performance parts) or a sequencer system (an automatic performance device), make sure the other instrument parts and channels do not overlap (p. 80).*

○ Bend Range (MIDI "BEND RANGE")

The GR-30 can even send continuous pitch changes obtained with techniques such as bending, finger vibrators, tremolo bar usage, and sliding to an external device. This is done using MIDI Pitch Bend Change messages, just as with the pitch bender on a keyboard. This means that the setting called Bend Range must be matched up on the sending and receiving instruments.

The GR-30 normally informs the external MIDI device of the Bend Range setting on the GR-30, and sends a message prompting change (○) every time the patch is switched.

This means that the Bend Range value on the sound generator can be set automatically every time the patch is changed simply by matching the maximum Bend Range value that can be set on the external MIDI sound generator to the GR-30 (Setting Bend Range to as large a value as possible will help enable smooth pitch changes in a wider range. The settable range varies according to the receiving sound generator. For equipment having a different settable width in the bend up and down directions, match the setting to the narrowest maximum value.)

○ About messages that notify the external MIDI instrument of the Bend Range and prompt change

The messages used here are MIDI RPN (Registered Parameter Number) "Pitch Bend Sensitivity" messages (Control Change messages No. 100, No. 101, No. 6, and No. 38). (Sending of these messages can be stopped, if necessary. → p. 84)

If you are using an external MIDI sound generator which cannot recognize such messages, manually change Bend Range on the external device to the same value on the GR-30. Refer to the Owner's Manuals for the external sound generator for information about its MIDI specifications.

<Setting the Channel (and Sending Mode) and Bend Range>

1. Press [EDIT/PLAY] to enter the Edit mode.
2. Set the EDIT TARGET dial to "MIDI" and the PARAMETER SELECT dial to "C" (CHANNEL).
3. Use [+] and [-] to make the display show "1" to "11" (Mono mode transmission), then change this to "1.P" to "16.P" (Poly mode transmission).
4. Select a matching channel and sending mode on the connected device, then set the PARAMETER SELECT dial to "D" (BEND RANGE).
5. Use [+] and [-] to switch the display to "0," "1," "2," "3," "4," "5," "7," "12," or "24," allowing the Bend Range to be selected.
6. Maximum the setting to the maximum value for Bend Range that can be set on the external sound generator, then press [EDIT/PLAY] to return to the Play mode. (These are system settings, and not patch settings, so there is no need to perform a patch write operation. The latest setting is automatically stored in memory, even after the power is switched off.)

➔ If the sending Bend Range on the GR-30 is set to "0," an effect similar to setting COMMON "CHROMATIC" (p. 40) to "on2" is obtained for the sounds from the external MIDI sound generator.

➔ When a multitimbral sound generator has been connected and Mono mode selected in step 3, the tones to be used are allocated to six parts on the sound generator. Also, the receiving channels are matched to the six connected channels selected on the GR-30. When in this state, you can play the external MIDI sound generator by playing the guitar even the GK-2A is mounted.

** If not sound is produced by the external MIDI sound generator, try turning the volume on the GK-2A all the up and setting the GK-2A's selector switch to "SYNTH" or "MIX."*

Also, if using an EXP pedal, press the pedal.

If there's still no sound, check the sound-level settings on the sound generator, as well as the cable connections. If the setting "PG CHNG#" described later (p. 72) has been changed, make sure that it is set to any setting other than "oFF" (off).

<When Using the Volume Knob and Selector Switch on the GK-2A>
When the volume on the GK-2A is adjusted, the change is sent by MIDI Control Change message No. 7 from MIDI OUT on the GR-30. (The receiving instrument should be set to recognize Control Change message No. 7.)

This makes it possible to control the volume level on the external device with the volume knob on the GK-2A. Also, when the selector switch on the GK-2A has been set to "GUITAR," a value of zero is sent to the external sound generator on the Control Change message No. 7, and sound from the external sound generator also stops. When "MIX" or "SYNTH" is selected, values corresponding to the state of the GK-2A volume or the EV-5 are sent, and sound production is restarted.

➔ *Sending of Control Change message No. 7 can be stopped when necessary (p. 83).*

Transmitting in Mono Mode or Poly Mode

Transmission in Mono or Poly mode, one or the other of which was selected at the same time as the channel in the preceding steps, differs as follows.

○ Transmitting in Mono Mode

Number of channels used: One channel per string is used. The number selected when specifying the channel in the Edit mode is taken as the start for automatically selecting six consecutive channels.

(For example, when "3ch" is selected, the six channels from channel 3 to channel 8 are sequentially used for strings 1 through 6. This means that no channel from 12 to 16 can be selected as the starting channel when transmitting in Mono mode.)

Features:

Information on continuous pitch changes (MIDI Bend messages) can be sent independently for each string. This makes it possible to reproduce unique guitar techniques such as tremolo bar usage and harmonized bending.

Suitable usage conditions:

Mainly when using a multitimbral sound generator offering six or more parts

○ Transmitting in Poly Mode

Number of channels used: A single common channel for all strings is used. The sending channel set in the Edit mode is used as-is.

Features:

Only a single channel is used for all guitar parts, so the number of MIDI channels used can be reduced. This enables control even for sound generators which cannot receive simultaneously on six channels. However, it should be noted that when two or more strings are playing, Bend messages are not sent and the pitch changes at semitone intervals. This means that the pitch actually being played on the guitar cannot be reflected perfectly in the synth sound.

Suitable usage conditions:

When using an external sound generator with five or fewer parts, or when the number of MIDI channels (sound generator parts) must be reduced

Changing Patch and Other Parameters by Transmitting MIDI Messages from the GR-30 (PG CHNG#)

When the pedals or the [+] and [-] buttons are used to change patches on the GR-30, a Program Change (tone change) message is sent to the external device from MIDI OUT. This can be used to change tones on the external sound generator or to change patches for guitar-sound effects.

The number of the Program Change message that is sent can be freely changed and saved to the patches on the GR-30. (At the time of purchase, Program Change numbers 1 through 128 are assigned sequentially to patches A11 through d84.)

<Changing the Program Change Number Sent to the External Device During Patch Selection>

1. Choose the patch to be changed and press [EDIT/PLAY] to enter the Edit mode.
2. Set the EDIT TARGET dial to "MIDI" and the PARAMETER SELECT dial to "A" (PG CHNG#).
3. Set the STRING SELECT knob to "ALL."
4. Use [+] and [-] to change the displayed Program Change number (within the range of 1 to 128).
5. After making the setting, turn the PARAMETER SELECT dial to "WRITE PATCH?", and press [+] and [-] simultaneously to write the patch.

If there is a patch which should be played using only the built-in sound generator, then in step 4 above, hold down [-] and select "oFF" (off). This stops the transmission of performance information (including information other than Program Change messages) for the patch from the GR-30.

Conversely, if there is a patch which should be played using only the external sound generator, just set the GR-30 patch "LAYER" setting (p. 34) to "_" (mute).

* It's not possible to alter the correspondences between Program Change numbers received by the GR-30 and the GR-30 patches called up by these numbers. The At the time of purchase, Program Change numbers 1 through 128 are assigned sequentially to patches A11 through d84, and this cannot be changed.

If you wish to make the sending numbers and the receiving numbers match up again, hold down pedal 2 and switch on the power (causing "PG#" to appear on the display), press [EDIT/PLAY], then press [+] and [-] simultaneously (for details → p. 81).

When You Want to Have Separate Sounds Programmed for Different Strings

It's possible to set different Program Change messages sent to an external sound generator not only for each patch, but even for each string.

In steps 3 and 4 of the procedure just described, "Changing the Program Change Number Sent to the External Device During Patch Selection," set the STRING SELECT knob to any string-number position other than "ALL" (such as 6-5, 6, 5, or the like), then use [+] and [-] to make the change. This method makes it possible to change the Program Change number for just the string selected with the knob.

This also makes it simple to do unusual things like assigning a different tone to each of the six strings with the external sound generator. You can also mute out certain strings for the external sound generator by using the setting "OFF" (off) for the desired strings.

* You can make settings for different strings for an external MIDI sound generator using the STRING SELECT knob not only for Program Change messages, but for sending MIDI Bank Select messages as well (see the next section).

Selection of More Than 128 Tones (MIDI BANK SELECT)

Many recent MIDI sound generators offer more tones than there are Program Change numbers (1 to 128). These sound generators use MIDI Bank Select messages (Control Change No. 0 and No. 32) along with Program Change messages when a tone is called up.

* The "bank" referred to here is an extended Program Change message set forth in the MIDI specification, and has absolutely nothing to do with the GR-30's bank number (the second place of the display that is, the "Bank" in "Bank Shift," "Bank Up, and "Bank Down"). Care should be taken not to confuse the two.

Example 1

When calling up the "12-str.Gt" variation tone of "Steel-str.Gt" with what is known as a GS-format sound generator...

Send the value for Control Change No. 0 ("8"), then send Program Change "26."

Example 2

When calling up patch 014 "MKS-80 Brass" in Preset Bank C on the Roland JV-2080, XP-80, or the like...

Send the value for Control Change No. 0 ("81" — Preset) and the value for Control Change No. 32 ("2" — C bank), then send Program Change "14."

The GR-30 also supports this function for sending Bank Select messages. This function is off at the time of purchase, but can be switched on and used with the following steps.

<Sending MIDI Bank Select Messages>

1. Choose the patch to be changed and press [EDIT/PLAY] to enter the Edit mode.
2. Set the EDIT TARGET dial to "MIDI" and the PARAMETER SELECT dial to "A" (PG CHNG#).
3. Press pedal 2. The display shows "b.SL" (Bank Select), then the current state ("OFF").
4. Press [+] to switch on the function.

* This selection (on or off) affects all patches, and is saved automatically even when no patch write is performed.

5. Set the STRING SELECT dial to "ALL."
6. Press pedal 3. The display shows "#.0" (Control Change No. 0), then the current state. (At the time of purchase, this is "0" for user patches.)
7. Use [+] and [-] to set the value for the tone to be called up (from 0 to 127).
8. Press pedal 4. The display shows "#.32" (Control Change No. 32), then the current state. (At the time of purchase, this is "0" for user patches.)
9. Use [+] and [-] to set the value for the tone to be called up (from 0 to 127).
10. Press pedal 1. The display shows "PrG." (Program Change), then the current Program Change number.

11. Use [+] and [-] to change the displayed Program Change number (within the range of 1 to 128).

12. After making the setting, turn the PARAMETER SELECT dial to "WRITE PATCH?", and press [+] and [-] simultaneously to write the patch.

When you call up a patch for which the settings described above have been made, the Bank Select message and Program Change number set in steps 6 to 11 are used to call up a tone on the external MIDI sound generator at the same time. (If you wish to continue by specifying a tone called up together with the external sound generator for another patch, you can skip steps 3 and 4 above.)

If you're making a different setting for each string, then in step 5 above, set the STRING SELECT knob to any string-number position other than "ALL" (such as 6-5, 6, 5, or the like), and use [+] and [-] to change "PG.#," "#.0," and "#.32."

➔ When making the MIDI "PG CHNG#" setting, using [+] and [-] to change the Program Change number or changes Control Change No. 0 or No. 32 causes MIDI messages corresponding to the selected numbers to be sent to the external MIDI sound generator as required, and the setting results appear on the external MIDI sound generator.

Also, if you move through the values quickly, such as by holding down [+] or [-], the external sound generator may overflow with MIDI messages and issue a corresponding warning message (such as "MIDI Buffer Full"). This does not occur when moving quickly through the patches in the Play mode.

➔ The setting "b.SL" (Bank Select) is common for both sending and receiving, combinations of Bank Select and Program Change messages from an external device can be used to freely call up any of the 256 patches in the unit when this setting is on and the GR-30 is receiving.

Preset patches (E11 through H84) can be called up with Control Change No. 0 value "1" and the appropriate Program Change message (1 through 128). Also, user patches (A11 through D84) can be called up with Control Change No. 0 value "0" and the appropriate Program Change message (1 through 128).

The receiving-side correspondences for user patches are also fixed and cannot be changed, even by overwriting the Bank Select and Program Change messages being sent.

➔ If a MIDI foot controller such as the FC-200 or Boss FC-50 is connected (p. 20), using the foot controller to switch patches on the GR-30 causes Program Change messages and the like written to the called-up patch for the external MIDI sound generator to be sent from MIDI OUT, making it possible to control all downstream devices as a group (except when MIDI Local Control is off → p. 78).

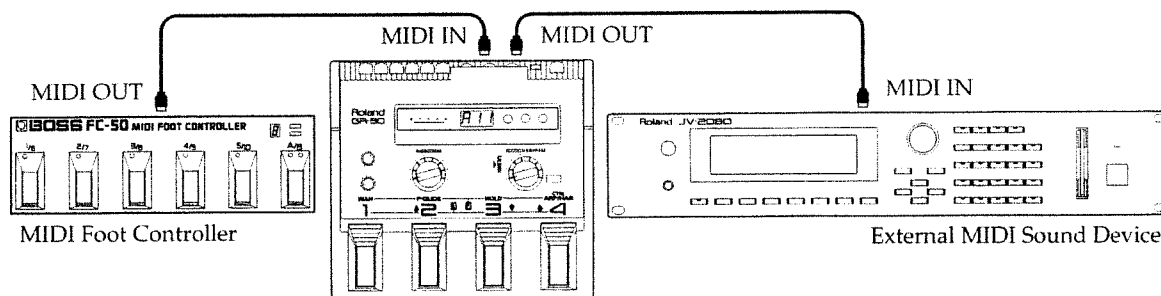

Performing the operation to sort Program Change numbers (➔) returns all Control Change No. 0 and No. 32 values to "0" for user patch Bank Select messages.

➔ Switch on the power while holding down pedal 2. → Press [EDIT/PLAY]. → Press [+] and [-] simultaneously.

How to Apply the Arpeggiator or Harmonist Using an External Sound Device

○ Using Arpeggiator to Arpeggiate an External MIDI sound generator

You can use the GR-30's Arpeggiator to arpeggiate the sounds of an external MIDI sound generator in the same way as for the internal first and seconds tones.

Follow the steps on p. 55 to set "ARPEGGIO/harmony SEL" to "ARP", "A.-E", "A.1E", or "A.2E." When you play the guitar the tones of the external MIDI sound generator are arpeggiated in accordance with the related settings.

○ Using Harmonist to Create Harmonies with the External MIDI Sound Generator

Follow the steps on p. 66 to set "ARPEGGIO/harmony SEL" as described below according to the kind of harmony you wish to create.

The guitar is the melodic line, and the external sound generator is used to create the harmony.

"hAr" or "h.-E"

The GR-30 sound is the melodic line, and the external sound generator is used to create the harmony.

"h.-E"

The tones of the external sound generator are the melodic line, and the GR-30 sound is used to create the harmony.

"h.-b"

The external sound generator and the GR-30's first tone are the melodic line, and the second tone is used to create the harmony.

"h.-2"

The external sound generator and the GR-30's second tone are the melodic line, and the first tone is used to create the harmony.

"h.-1"

The first tone is the melodic line, and external sound generator and the GR-30's second tone are used to create the harmony.

"h.-2E"

The second tone is the melodic line, and external sound generator and the GR-30's first tone are used to create the harmony.

"h.-1E"

The Relationship Between Envelope Follow Function and MIDI Message

Patches that use the Envelope Follow function (p. 38) — in other words, patches for which "EF1" or "EF2" has been selected for the COMMON "PLAY FEEL" setting — send information on string amplitude (decay) during play to MIDI OUT on MIDI Control Change No. 18 (general control 3).

This is mainly used during recording and playback of performances on the GR-30 itself through a loop connection with a MIDI sequencer (p. 77), and is for recording guitar-string envelopes (decay information) along with the played sounds and playing back the performed sounds without change.

When using an external MIDI sound generator that can assign tone changes and other effects to any desired Control Change message that is received, you can also use No. 18 (sent as described above) to create changes in sounds.

About Pedal Control for External MIDI Devices

The GR-30's built-in pedal effects and some expansion pedal effects can also be applied to an external sound generator.

○ Pedal Effect 1 (WAH)

Messages about pressing and releasing the pedal are sent on Control Change No. 19. This becomes some effect or another when interpreted by the external sound generator. When "Mod" (modulation) has been selected as the "WAH TYPE" setting (p. 45), Control Change No. 1 is used, not No. 19.

○ Pedal Effect 2 (P-GLIDE)

MIDI Pitch Bend messages are used to create an effect similar to the effect for the built-in sound generator.

○ Pedal Effect 3 (HOLD)

This is achieved by causing issuance of MIDI Note Off messages to be paused during a hold. (A Control Change No. 64 used with keyboards is not sent. For control of the internal sound generator, however, pedal action is sent on Control Change No. 82 (general control 7).)

** When transmitting in Poly mode (p. 72), string-specific processing is impossible when the same pitch is played on different strings, so the hold effect can not be perfectly conveyed.*

○ Pedal Effect 4 (CTRL ARP/HAR)

Arpeggiator and Harmonist can be turned on and off in the same way as for the built-in sound generator.

<About Expression Pedal Effects>

When an expression pedal is used to apply some sort of effect to the built-in sound generator, the pedal's action is output from MIDI OUT. This output is usually made with Control Change No. 4 (foot type), but other numbers can be used by changing the "EXP PEDAL" setting (p. 49) as follows.

"Vol" (Volume)

Control Change No. 7

"Pit" (Pitch)

MIDI Pitch Bend messages

"Mod" (Modulation)

Control Change No. 1

"L-r" (Total Pan)

Control Change No. 10

"rE.L" (Reverb Level)

Control Change No. 91

"t.n.P." (Tempo and Pitch)

MIDI Pitch Bend messages and Control Change No. 4

In addition to these, when a value from "#1" to "#32" or from "#64" to "#95" has been selected for the "EXP PEDAL" setting (p. 49), the Control Change message of the corresponding number follows the operation of the expression pedal and is output only from MIDI OUT. This makes it possible to use the pedal to control only the external MIDI sound generator.

** When the GR-30 receives Control Change No. 4, the synth sound of the GR-30's internal sound generator changes according to the function assigned to the expression pedal at that time. However, when a function using a specific Control Change message such as the foregoing No. 7, No. 1, or No. 91 has been assigned, No. 4 is ignored.*

Transposing Performance Data for an External Sound Generator (TRANPOSE)

When using an external sound generator, notes in the bass (or treble) range not on the guitar can be sent by changing the MIDI "TRANPOSE" setting to transpose the output from MIDI OUT.

The settings can be made by using a procedure that is exactly the same as transposition for the built-in sound generator (TRANS 1ST/2ND → p. 34), except that the EDIT TARGET dial is set to "MIDI" and the PARAMETER SELECT dial is set to "B".

What to do if an External Module Doesn't Produce Sound as Expected

If the external sound generator doesn't play as expected, double-check the following items.

- Make sure the sending and receiving MIDI channels match (p. 71).
- Make sure the volume level on the external sound generator has not been lowered by sending a MIDI Volume message because of operation of expression pedal volume on the GR-30.
- Make sure the volume on the GK-2A or the expression pedal has not been turned down too low.
- Make sure that a sound generator which cannot simultaneously receive six MIDI channels is receiving data from the GR-30 in the Mono mode (p. 72).

** If the pitch sounds out of tune with the guitar, check "BEND RANGE" (p. 71).*

** If "BEND RANGE" has been set to "0," the pitch will change in semitone.*

** When transmitting in the Poly mode, pitch changes during chord performances are in semitone (p. 72).*

Using the GR-30 as an External Sequencer Input Tool

By connecting the GR-30 to a MIDI sequencer (a performance-recording and playback device), even guitarists who don't play keyboards can perform real-time recording to the sequencer.

Connecting to a Sequencer

Use MIDI cables to hook up the GR-30, sequencer (or computer running sequencer software) and multitimbral sound generator as shown in the figure.

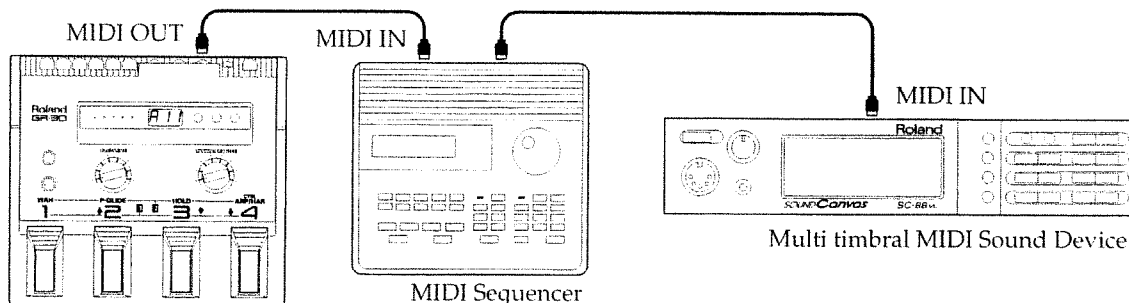

Input Procedures and Settings for Each Device

1. Follow the procedure on p. 71 to set the sending channel, sending mode, and bend range on the GR-30 to match the sound generator being used.
2. Turn on the Data Thru function (also called "Soft Thru") for MIDI IN → OUT on the sequencer. (Make the setting so that MIDI message output from the GR-30 during recording is also output through MIDI OUT on the sequencer.)
3. Switch on the power to the GR-30 while holding down the [EDIT/PLAY] key to enable the "Local Control Off" state (described later → p. 78). When doing this, the display reads "L__", and then the unit starts.
4. When everything is ready, play the guitar and make sure the external sound generator produces sound. If no problem is found, operate the external sequencer to start recording. When the recording is done, put the sequencer in the play mode and check what you've recorded.
5. If you also wish to use the GR-30's sound generator in the song, make the connections shown in the figure above, and also connect MIDI THRU on the external sound generator to MIDI IN on the GR-30. This makes it possible to use the GR-30 sound generator as well while listening to the performance of the external MIDI sound generator parts. (At this time, the sending MIDI channel should be selected so as not to conflict with the channel setting on the external sound generator.)

The setup just described can also be used to record tone changes and effects from the built-in and external pedals (p. 22, 49) in addition to the sounds from the guitar performance. (While using Harmonist, pressing the "Up" side of an external BANK SHIFT pedal in the Pedal Effect mode toggles it between a major and minor key, and this information is also sent and recorded in the form of System Exclusive (SysEx) messages.)

- * If you wish to record in a bass range that cannot be produced by the guitar, change the MIDI "TRANPOSE" setting to "-12" (down one octave) or "-24" (down two octaves).
- * If the sequencer you're using doesn't support simultaneous recording on more than channel, use the Poly mode for sending and recording (p. 72).

About "Local Control Off"

While the GR-30's internal sound generator and guitar controller are connected together, it is set to "Local On." In contrast to this, "Local Off" is when the GR-30's internal sound generator and guitar controller are separated, and only MIDI message from a sequencer is played. Also, guitar performance message is output only from MIDI OUT.

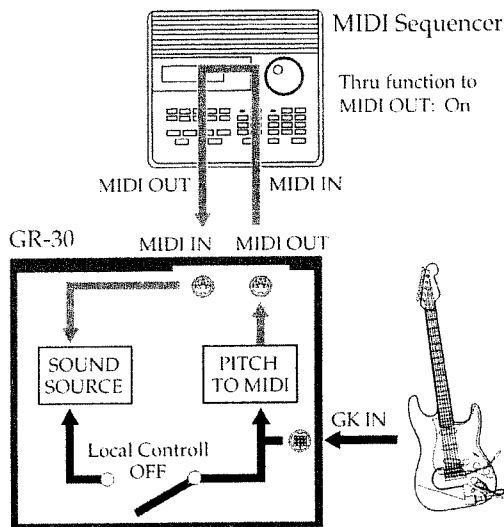

Collisions of performance data from both the guitar and the sequencer that occur at times such as when "soft thru" is enabled can be prevented by turning off local control.

To turn off local control, switch the power off and back on while holding down the [EDIT/PLAY] button. Also, local control is automatically switched off when the Polyphonic function is called up at powerup. (The setting for turning off local control is canceled when the power is switched on, and is not saved in memory.)

* The detailed behavior of internal functions differs depending on whether local control is on or off. Local control is normally on, but you should be sure to switch off local control when a loop connection with external equipment is used.

Making a MIDI loop connection with local control remaining on may result in problems or faulty operation, such as failure to recognize switch operations.

Creating Realistic Plucked String Instrument Sounds (Data)

Using the GR-30 to input parts for guitars and similar string instruments, including harps, koto, and others, makes it possible to achieve voicing and an expressive feeling of dispersions for separately plucked strings that cannot be reproduced with keyboard input. When doing this, however, attention should be given to the following points.

- Make sure that no Quantize function (a function which forces data with loose input timing to conform to precise timing as eighth notes, sixteenth notes, or the like) has been enabled for input-data timing on the sequencer.
- When performing post-recording operation on the sequencer to shift the position of data, make sure that Bend messages are also shifted along with Note messages, so as not to destroy the correspondences between the two types of messages.

Also, those special changes in pitch that can only be produced by a guitar synthesizer (such as using the tremolo bar and harmonized bending) can also be input to the sequencer and played by means of transmission in the Mono mode, which uses one MIDI channel for each string.

How to Record Arpeggiator and Harmonist Performances

<Recording Arpeggiator Effects on a Sequencer> Example 1

Arpeggiate the notes of the external MIDI sound generator, and record the results
Set "ARPEGGIO/harmony SEL" to "A-E", and while in the same state as step 4 of "Input Procedures and Settings for Each Device" on p. 77, play the guitar and make sure the external MIDI sound generator is arpeggiated. After that, continue from step 5 to record.

Example 2

Arpeggiate the GR-30's first and second tones, and record the results
Set the patch "ARPEGGIO/harmony SEL" setting to "A-1", "A-2", or "A-b", and carry out recording. (Arpeggios are played while recording, but only the original guitar-performance information — and not arpeggio information itself — is recorded on the sequencer.) If the same patch is used during playback, performance information is received from MIDI IN and the GR-30 rebuilds the arpeggios.

* The setting "ArP" is not suitable for "ARPEGGIO/harmony SEL" when a sequencer and the GR-30 are connected by a MIDI cable (local control off).

* As in Example 1 above, it is perfectly all right to record the arpeggios themselves with "A.-E", then return this data unchanged from MIDI OUT on the sequencer (to a patch for which first and second tone arpeggios are off) to re-create the arpeggios. However, this method cannot be used to re-create performance where both tones were played but only the first tone was arpeggiated.

* When using transmission in the Poly mode (p. 72), only the method described for Example 2 can be used to recording and playback.

It's also possible to carry out recording with the GR-30's Arpeggiator synchronized to the sequencer's tempo.

First, follow the steps on p. 56 to set the ARPEGGIO/harmony "A-TEMPO" setting for the patch to be used to "Syn.". Then make the connections shown in the figure on p. 77, and in addition, use a MIDI cable to connect the MIDI THRU connector on the external sound generator to MIDI IN on the GR-30. Next, turn off local control by switching on the power to the GR-30 while holding down the [EDIT/PLAY] (p. 78), then carry out recording. (When recording parts from an external MIDI sound generator, turn down the VOLUME knob on the GR-30.)

<Recording Harmonist Effects on a Sequencer>

Example 1

Make the first tone the melody and the second tone the harmony (or vice versa), and record the results. Set the patch "ARPEGGIO/harmony SEL" setting to "h.-2" (or "h.-1"), and while in the same state as step 4 of "Input Procedures and Settings for Each Device" on p. 77, play the guitar and make sure the desired harmony is obtained. After that, continue from step 5 to record. The same harmony created when recording can be reproduced by using the same patch during playback.

Example 2

Make the notes from the external MIDI sound generator the melody and the first and second tones the harmony, and record the results. Set "ARPEGGIO/harmony SEL" to "h.-b", carry out recording in the same way as for Example 1, and play back the performance using the same patch. Make sure that the external sound generator and the GR-30 are set to the same MIDI channel at this time.

* It's not possible to record with the GR-30 as the melody and the external MIDI sound generator as the harmony.

* The setting "hAr" is not suitable for "ARPEGGIO/harmony SEL" when a sequencer and the GR-30 are connected by a MIDI cable (local control off).

Reducing the Size of a MIDI Pitch Bend Message

The amount of Pitch Bend messages that are sent can be reduced by using the Bend Data Thin function. Although the smoothness of pitch changes deteriorates, this can reduce the amount of MIDI data.

To call up the Pitch Bend Data Thin function, switch on the power to the GR-30 while holding down the [-] button. When this is done, "b" (bend data thin) appears as the second character in the display before the unit starts up. This results in a reduced amount of pitch bend data transmissions until the power is turned off. (While this function is active, the smoothness of pitch changes for the internal sound generator is also restricted.)

<About the Bend Data Thin Function>

With the guitar, the finger vibrato technique can be used to produce organic vibratos with amplitude and speed that can be freely varied — something that's very hard to do with a keyboard.

When creating sequencer data, the GR-30 records such finger vibratos, glissandos, and tremolo bar usage as MIDI Pitch Bend messages. As a result of this, the MIDI performance message that is output contains a large number of Pitch Bend messages. In some cases, however, these Pitch Bend messages can greatly inflate the amount of data and exceed the sequencer's memory capacity.

The Bend Data Thin function is available to keep this to a minimum.

* The Bend Data Thin function can also be used together with the Polyphonic Receive function (p. 82). When this is necessary, switch on the power while simultaneously pressing [+] and [-].

Practical Use of MIDI Channels

Transmitting in Mono Mode

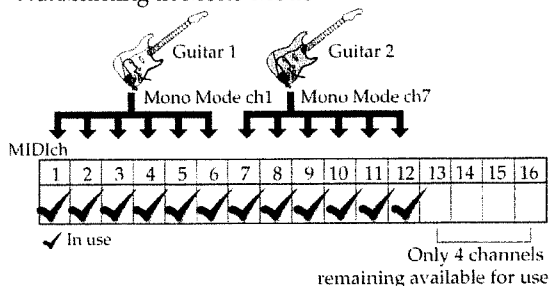

Transmitting in Poly Mode

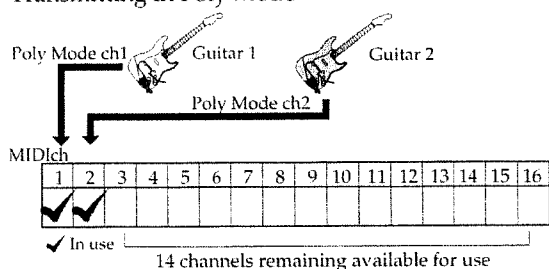

A single MIDI system has 16 channels, and ordinarily 16 instrument parts can exist. With a guitar synthesizer, however, each of the six strings takes up one channel.

This means that, for instance, two-part input with the guitar synth to an ensemble from a 16-part external multitimbral sound generator would use up 12 channels.

In cases like this, set the MIDI channel (p. 71) to a value from "1.P" to "16.P" and send input to the sequencer with Poly mode sending. This lets you proceed with recording while using up only one channel per part, as with a keyboard instrument.

One drawback of transmitting in Poly mode is that it is not possible to send Pitch Bend messages for bending, sliding, vibratos, and the like when playing chords, but this mode can help in economical use of channels and parts when used judiciously separately from Mono mode input while giving consideration to the tones to be used and to single-note playing.

Also, when also adding the GR-30's sound generator to the ensemble, the use of Poly mode for receiving as well as sending lets the GR-30's parts use just one channel, leaving the remaining 15 channels for use by the multitimbral sound generator.

To enable receiving in Poly mode, switch on the power while holding down the [+] button. (At this time, the GR-30 starts up unconditionally with local control off.) For a detailed explanation of behavior when receiving in Poly mode, take a look at "Using the GR-30 As an Expansion Sound Device for Keyboards and Like Devices (Poly Mode)" on p. 82.

What to do When You Have Difficulty Sequencing

- Double-check the MIDI cable connections (OUT -> IN, p. 77) and the setting for local control (on or off — p. 78).
- When performing playback, be sure to check the MIDI channel and Bend Range settings (p. 71).
- Be sure that the transmitting and receiving modes (Mono or Poly) match up. If only the sound for one string is heard during playback, you may be sending performance data to created with transmission in Mono mode a non-multitimbral sound generator (including the GR-30, if set for receiving in Poly mode).
- If MIDI cannot be sent and recording is impossible for only a particular string, adjust the STRING SELECT knob to the string's number and make sure that the MIDI "PG CHNG#" setting is not "oFF" (p. 72).
- During transmission in Poly mode, pitch changes for chord play are in semitone steps. If continuous change in pitch is needed, use single-note playing or transmission in MIDI Mono mode.
- If MIDI Bend Range is set to "1" or "2," unpleasant retriggering of sounds may occur frequently during a performance with continuous changes in pitch through bending or the like. When using the same Bend Range setting for both sending and receiving, make the value as large as possible (p. 71).
- To achieve faster sound generation and smooth pitch changes, the GR-30 transmits pitch as a combination of Note messages and Pitch bend messages. This means that if the sequencer's microscope (event list) screen shows only Note messages, what appears on-screen may differ from what is actually performed. If continuous pitch change is not required, you can create data that is displayed more faithfully by setting the sending Bend Range to "0."

Chapter 11: Other Convenient Functions

Restoring the Settings to Their Defaults (Initializing)

At the time of purchase, the GR-30's user patches (A11 to d84) have been same content as preset patches E11 to H84. These settings, as well as system settings such as pickup sensitivity and MIDI channels for sending and receiving, can be returned to the values they had when the GR-30 was purchased.

<Restoring the Defaults (All Settings/Patches Only/ System Settings Only)

1. If you wish to save the present settings, you can either write down the settings or follow the steps on p. 31 to back up the data on an external MIDI instrument.
2. Switch off the power, then turn it back on while holding down (depressing) pedal 2. The message "PG#" flashes on the display.
3. Press [+] one to three times to select the item to be returned to its default value ("PAt." ("patch": patch content), "SyS." ("system": system-related settings), or "ini." ("initialize": all settings).
4. Press [EDIT/PLAY]. The confirmation message "Sur." ("Are you sure?") flashes on the display. If you press [+] and [-] simultaneously at this point to answer "yes," the item selected in step 3 is returned to its default value, and the message "don." ("done") appears after a short pause.

** If "PAt." or "ini." is selected as the item to be initialized, the display flashes "..." (three periods) several times before showing "don." ("done"). This means that processing of the patch data is in progress, so do not turn off the power until "don." is displayed.*

Recordering the Program Change Numbers from the Beginning

If you have repeatedly changed the original settings for some patches and written these patches of your own creation on the different patch numbers, or if you have reordered the patches, the MIDI "PG CHNG#" setting may become irregular and have no connection with the patch-number sequence.

If it becomes necessary to again match these up with the receiving-side Program Change numbers, which are fixed in sequence from the beginning of the patches, follow the steps below to reorder the sending Program Change numbers from the starting patch.

** Please note that using this operation causes all "PG CHNG#" settings for patches to be lost.*

1. Switch off the power, then turn it back on while holding down (depressing) pedal 2. The message "PG#" flashes on the display.
2. Press [EDIT/PLAY]. The confirmation message "Sur." ("Are you sure?") flashes on the display.
3. Press [+] and [-] simultaneously at this point to answer "yes." The sending Program Change numbers are reordered in sequence starting from the first patch (1, 2, 3, ..., 127, 128), and the message "don." ("done") appears after a short pause. (All Control Change No. 0 and No. 32 values are returned to "0" for the sending Bank Select messages for user patches.)

Using the GR-30 as an Expansion Sound Device for Keyboards or other MIDI Devices (Poly Mode Reception)

The GR-30's built-in sound generator normally receives in the Mono mode, which uses six MIDI channels. This means that when using the GR-30 as an expansion sound generator for a general external device (such as a keyboard or sequencer system), single notes cannot be sounded without modifying some settings.

If chords must be sounded, follow the steps below to call up the "Polyphonic Receive" function when using the GR-30. This lets you use the GR-30 as a polyphonic MIDI sound generator using only one MIDI channel.

<Calling Up the "Polyphonic Receive" Function>

Switch off the power, then turn it back on while holding down the [+] button. The message "L_P" (local control off, polyphonic receive) appears on the display, and the unit starts up.

** When start up with the Polyphonic Receive function on, local control is always automatically turned off.*

○ Characteristics of Operation During Polyphonic Receive

- Up to 28 notes (28 voices) can be sounded polyphonically using the tones of the currently selected patch. (The number of notes that can be played simultaneously varies according to the tones and layers in use. Some tones use 1 voice and others use 2 voices.)

- The "TRANSPOSE" and "LAYER" states are all based on the settings for the first string.
- If Note On messages that exceed the permitted number of sounds are received, the sounds are dropped out sequentially, starting with the first ones (first in, first out).
- The Polyphonic Receive function stops when the power is turned off (that is, the setting is not saved in memory).
- The Polyphonic Receive function cannot be used together with the Bend Data Thin function (p. 79). If required, switch on the power while simultaneously holding down the [+] and [-] buttons.
- When using the GR-30 as an expanded sound module for a MIDI keyboard or the like, the "HOLD" and "P-GLIDE" functions assigned to the unit's pedals cannot be used. (Play does respond to operation of the Bender knob on the keyboard. Also, Control Change No. 64 due to operation of the keyboard's damper pedal cannot be recognized only when receiving in Poly mode has been selected.)
- Arpeggiator does not function at all when using the function for receiving in Poly mode.

** Even when using the GR-30 as an external sound generator while left for receiving in Mono mode (which uses six channels), the sending channels from the external device must be set to match the starting channels on the GR-30.*

Using the GR-30 with a Number of Guitars (GUITAR SELECT)

There may be times during live performances when you have to rapidly switch the guitars that use the GR-30.

For instance, you may need to use both a solid guitar and an acoustic guitar for some songs, or a broken string may force you to switch to a spare guitar equipped with a GK-2A.

In cases like these, the GR-30 can save the settings for pickup sensitivity (PICKUP SENS 1 to 6) matched to the state of the installed GK-2A for up to four guitars (i.e., four settings). This means that you can save the sensitivity settings for all the guitars that you are likely to use, allowing you to change guitars smoothly when the time comes.

<Getting Ready and Changing Guitars>

1. Press [EDIT/PLAY] to enter the Edit mode, and set the PARAMETER SELECT dial to "GUITAR SELECT."
2. Use [+] and [-] to choose "Gt.1" (guitar 1).
3. Set the PARAMETER SELECT dial to "PICKUP SENS (1-6)" and follow the steps on p. 14 to adjust the sensitivity.
4. Set the PARAMETER SELECT dial to "GUITAR SELECT" and use [+] and [-] to choose "Gt.2" (guitar 2), then connect the GR-30 to the next guitar (GK-2A) and make the sensitivity setting.
5. Repeat the same steps to set the sensitivity for up to four guitars ("Gt.4"). When you're done, change the "GUITAR SELECT" setting to the number of the guitar you intend to use when the power is turned on, then press [EDIT/PLAY] to return to the Play mode.

When you're on stage and need to change guitars, go into the Edit mode and change the "GUITAR SELECT" setting to the number of guitar you want to use. The sensitivity setting that you made earlier is called up when you return to the Play mode.

Terminating Transmission of the MIDI Controller No. 7 (Volume)

Control Change No. 7 is used not only for sending the status of the GK-2A's volume knob, but also for the "SYNTH - MIX - GUITAR" selector switch.

However, you may occasionally encounter a MIDI-capable effects processor which cannot be set to ignore volume control by Control Change No. 7.

This is a point that requires attention, because when the GR-30 has been hooked up with MIDI cables for the use as an external effects processor for guitar sounds, setting the selector switch on the GK-2A to "GUITAR" in such cases may mute out even the guitar sound, not just the synth sound.

When using the GR-30 in combination with this kind of effects processor, follow the steps below to stop the GR-30 from sending Control Change No. 7.

1. Switch off the power, then turn it back on while holding down (depressing) pedal 2. When "PG#" is displayed, press pedal 1 to make "7.on" appear on the display.
2. Press [-] to change to "7.oF." (To return to the original setting, press [+] at this screen.)
3. Press [EDIT/PLAY] to return to normal operation (the Play mode).

This stops the transmission of Control Change No. 7 from MIDI OUT, eliminating the problem described above.

** This also terminates transmission of Control Change No. 7 messages for other volume-related control, so this setting should not be changed except when necessary. Please note that once transmission has been stopped, the setting is automatically stored in memory and transmission remains stopped even after the power has been turned off, unless you return the setting to "7.on" or restore system-related settings to their default values (p. 81).*

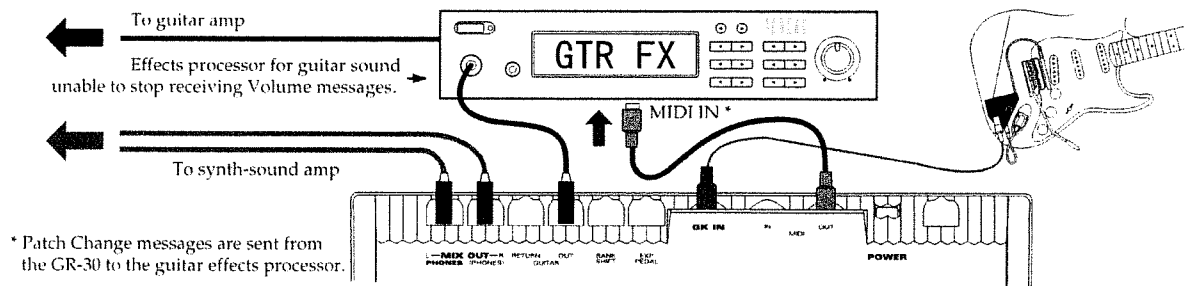

Terminating Transmission of the Bend Range Request Message

Each time the GR-30 changes patches, the external MIDI device is informed of the Bend Range setting on the GR-30, and a message requesting change is sent. The messages used here are MIDI RPN (Registered Parameter Number) "Pitch Bend Sensitivity" messages — that is, Control Change messages No. 100, No. 101, No. 6, and No. 38.

If it is necessary for some reason to stop this (such as when it may be desirable to reduce the number of messages sent when changing patches while programming the sequencer), follow the steps below to turn off this function.

1. Press [EDIT/PLAY] to enter the Edit mode, and set the EDIT TARGET dial to "MIDI" and the PARAMETER SELECT dial to "D" (BEND RANGE).
2. Press pedal 2 to display first "b.rq" (bend change request) then "on."
3. Press [-] to change the display to "oFF" (off). (To return to the original setting, press [+] at this screen.)
4. Press [EDIT/PLAY] to return to the Play mode.

Once you've done this, no Bend Range Request messages (MIDI Pitch Bend Sensitivity) are sent when changing patches.

** Please note that once transmission has been stopped, the setting is automatically stored in memory and transmission remains stopped even after the power has been turned off, unless you return the setting to "on" or restore system-related settings to their default values (p. 81).*

Chapter 12: Appendices

Troubleshooting

■ During Normal Play with Just the GR-30

● No synth sounds are heard when the guitar is played

- ◆ If the unit's volume knob turned down too low?
→ Adjust the volume to an appropriate level.
- ◆ Is the volume on the GK-2A turned down too low?
Is the GK-2A's selector switch set to GUITAR?
→ Set the switch to SYNTH or MIX, and adjust the volume to an appropriate level.
- ◆ Has the expression pedal assigned with the Volume function been returned to its raised position?
→ Depress the expression pedal.
- ◆ Has neither the first nor second tone been selected for the Layer setting?
→ Assign the first (or second) tone to each of the strings (p. 34).
- ◆ Is the "PATCH LEVEL" setting too low?
→ Adjust the setting to an appropriate level (p. 36).
- ◆ Is the Polyphonic Receive function (p. 82) being used?
→ In this case, the GR-30 is unconditionally set to "local control off" and stops producing sounds in the normal manner. (However, MIDI messages can be sent and received.)

● The pitch stays the same even when the Master Tune setting is changed

- ◆ The only sounds that immediately change in pitch when the GR-30's Master Tune setting is changed are synth sounds controlled by an external MIDI instrument. Except when the patch "CHROMATIC" setting is set to a value from "on1" to "on3", synth sounds controlled by the guitar follow the guitar's actual pitch, regardless of the Master Tune setting.
→ After making the Master Tune setting (p. 15), use the built-in tuner to retune the guitar (p. 15) and ensure that all pitches (including the guitar) are in tune.

● The Layer setting is correct, but one tone is not heard

- ◆ Is "1:2 BAL" set too much to the first tone or the second tone?
→ Adjust the setting to obtain a suitable balance.
- ◆ Has the expression pedal assigned with tone balance been depressed (or returned to its raised position)?
→ Try operating the expression pedal or assigning a different function (p. 49).

● Volume fluctuates for some strings

- ◆ Are the PICKUP SENS settings correct for each string?
→ Adjust the settings as required (p. 14).

● Pitch doesn't rise when using Pitch Glide (or the expression pedal Pitch function)

- ◆ Functions that vary pitch continuously may experience a limited range of change during rising pitch due to the tone or register.
→ If a limitation is encountered, use with a narrower width of change (p. 46).

● The sound change produced by an expression pedal varies from one tone to another

- ◆ For some of the 384 tones, the way the effect is applied varies subtly from the usual case when the Brightness or Wah-Wah function is assigned.
→ Actually assign the function and check in advance how the effect is applied (p. 49).

● The way modulation is applied varies from one tone to another when using the unit's pedal effect or expression pedals

- ◆ Each tone has an independent setting for the speed of undulations in pitch when using modulation.
→ Check the undulations in advance and choose a tone with an undulation speed that matches the song.

- ◆ The “Mod” setting for the pedal effect (WAH) also has an independent setting in effect (undulation) depth for each tone.
→ Check the depth of the effect choose a tone with a depth that matches the song.

● One tone is not heard when the expression pedal is used to change the tone’s volume balance

- ◆ Is the TONE MIX “LAYER” setting set so that only the first or the second tone (but not both) is played?
→ Change the setting so that the first and second tones are both played (p. 34).
- ◆ Is the TONE MIX “1:2 BAL” setting (p. 35) set to “50” (or “-50”)?
→ Change the setting to a value closer to “0” and check operation.

● The effect doesn’t change even when the expression pedal is pulled back all the way

- ◆ Is the minimum volume for the expression pedal too high?
→ Lower the minimum volume.

● The built-in effects don’t have any effect

- ◆ Is the EFFECT “REVERB TYPE” setting (p. 42) or “CHORUS TYPE” setting (p. 43) set to “oFF” (off)?
→ Choose a type other than “oFF” (off).
- ◆ Is “REVERB LEVEL” too low?
→ Set “REVERB LEVEL” to an appropriate value.
- ◆ Is the EFFECT BYPASS indicator lit up?
→ Press [+] while holding down [EDIT/PLAY] to release the Bypass function.
- ◆ The GR-30’s built-in effects are exclusively for use with the internal synth sounds. They are not applied to the sounds of the guitar itself.
→ You can apply external effects for the guitar to only the guitar sounds by using the GUITAR OUT jack. (If you wish to use a single amp for both the guitar and synth sounds, you should also use the GUITAR RETURN jack as well.)
- ◆ Has the expression pedal assigned with the “rE.L” (reverb level) function (p. 49) been returned to its raised position?
→ Depress the expression pedal.

● The pitch of the synth sounds doesn’t change in the same way as the pitch of the guitar sounds

- ◆ Some tones (such as percussion instruments and effect sounds) show different changes in pitch than with the guitar. This is not a defect.
- ◆ If Harmonist is on, scale changes for synth sounds are different from the guitar when “ARPEGGIO/harmony SEL” (p. 66) is set to “hAr” or “h-b.”

● Noise with subtle undulations is hear in extremely high registers

- ◆ This is a phenomenon peculiar to digital sound generators known as “aliasing noise.” It may be audible when using the slide technique or the Pitch Shift function, but it is not a defect. The GR-30 is designed to minimize such noise during guitar play.

● Pitch doesn’t change smoothly

- ◆ Is COMMON “CHROMATIC” set to a value from “on1” to “on3”?
→ Set CHROMATIC to “oFF” (off) for patches that require continuous changes in pitch.
- ◆ Is the Bend Data Thin function (p. 79) in use? Using this function may result in a slight loss of smoothness when pitch changes, even during normal play.
→ Do not use the Bend Data Thin function when it is not needed.

● The message “bAt” flashes on the display when the power is turned on

- ◆ This is a warning that means that the internal battery which maintains patch and system data is almost dead. If this message appears, data may be lost if the battery is not replaced quickly.
→ Contact your music vendor or your nearest Roland Service Spot.

■ When Changing Patch Settings

● The display suddenly starts flashing

- ◆ The flashing green of the EDIT PATCH indicator shows that the currently called-up patch has been changed or modified in some way, or that a write operation has not been carried out. (In the Play mode, this flashes red as a warning.)
- ◆ Flashing of the text display when the STRING SELECT knob has been set to ALL (all strings) as a valid setting means that the current setting differs according to the string.

● The sound doesn't vary when the settings are changed

- ◆ the GR-30's Attack, Release, and Brightness settings are intended to adjust the original data belonging to each tone. This means that the range of change differs according to the tone, and some tones may not show much of a change.
- ◆ Is the setting being changed one of the five settings that can be made independently for each string (see the following item), and is the setting affecting only a particular string?
→ Turn the STRING SELECT knob to "ALL."

● Settings cannot be made independently for individual strings

- ◆ Is the setting one that cannot be made for individual strings?
→ The five settings that can be made independently for each of the strings using the STRING SELECT knob are TONE MIX "Layer," "TRANS 1ST," and "TRANS 2ND," and MIDI "PG CHNG#" and "TRANSPPOSE."

● No reverb is applied even when the reverb level is increased

- ◆ Is the EFFECT BYPASS indicator lit up?
→ Press [+] while holding down [EDIT/PLAY] to release the Bypass function.
- ◆ Is "REVERB TYPE" set to "oFF" (off)?
→ Choose a type other than "oFF" (off).

■ when Playing the GR-30 sound generator with a MIDI Keyboard or Other Instrument

● No sound is heard

- ◆ Do the MIDI channels for sending and receiving match?
→ Make sure the MIDI channels match (p. 71).
- ◆ The sending of Note messages and the like also stops for patches for which MIDI "PG CHNG#" is set to "oFF" (off).
→ Change the setting to a value from "1" to "128" (p. 72).

● Chords are not played, or keyboard damper play is not received

- ◆ Is the "Poly Mode Reception" (p. 82) in use? MIDI receiving by the GR-30 is normally fixed at the Mono mode. (Data is received in the Mono mode even if "transmission in Poly mode" is selected for the MIDI CHANNEL setting.) Also, MIDI Control Change No. 64 (damper pedal) is responds only when receiving in Poly mode.
→ Switch on the power while holding down the [+] button to call up the function.

● The P-GLIDE and HOLD pedal effects don't work

- ◆ The Hold and Pitch Glide functions cannot be used when play is controlled by MIDI messages from an external instrument (such as a keyboard).
→ Use the controls on the external instrument to apply pitch bending and holds.

● Single notes are sounded when MIDI messages are sent from the external instrument, but messages such as Program Change are not received

- ◆ While the GR-30 is receiving in Mono mode, are MIDI messages being sent to the five channels other than the first channel specified by the MIDI "CHANNEL" setting? MIDI messages other than Note messages and Bend messages must be sent to the first channel.
→ Be sure to send data from the external instrument to the first matching channel, even when the GR-30 is set up to receive data on six channels.

● Arpeggiator doesn't work

- Please note that Arpeggiator doesn't operate when using the Poly Mode Receive function.

■ When Sending Performance Data from the GR-30 to an External MIDI Device (sound generator or Sequencer)

● No sound from the external sound generator

- ◆ Do the MIDI channels for sending and receiving match?
→ Make sure the MIDI channels match (p. 71).
- ◆ The volume level of the external sound generator may have been lowered by a MIDI Volume message (Control Change No. 7) sent from the GR-30.
→ Raise the volume on the GK-2A.
- ◆ Is the volume for the GK-2A or expression pedals too low?
→ Use the controls to increase the volume.

● The external sound generator plays only one string (some strings can't be heard)

- ◆ Is the GR-30 using the Mono mode to send data to a sound generator which cannot simultaneously receive data on six MIDI channels?
→ For such sound generators, send data in the Poly mode (p. 72).

● Notes in a bass register not on the guitar cannot be played

- Output from MIDI OUT can be transposed as desired by changing the MIDI "TRANSPOSE" setting (p. 76).

● The pitch is wrong (out of tune with the guitar)

- ◆ Is MIDI Bend Range the same for both sending and receiving?
→ If the pitch is off, adjust the Bend Range setting (p. 71).

● Pitch doesn't change smoothly

- ◆ Is data being sent in the Poly mode? When transmitting in the Poly mode, pitch changes during chord performances are in semitone steps (p. 72).
→ Play with single notes, or use the Mono mode to send data.

- ◆ Is the Bend Data Thin function (p. 79) in use?
→ Do not use the Bend Data Thin function when it is not needed.
- ◆ Is MIDI "BEND RANGE" set to "1" or "2"?
→ When matching with sending and receiving, use as large a value as possible (p. 71).
- ◆ When "BEND RANGE" is set to "0", the pitch changes in semitone steps.
→ Change the setting to a preferable value.

● The Note messages input to the sequencer don't look like the scale that is actually played

- ◆ To start playing sounds rapidly and achieve smooth changes in pitch, the GR-30 transmits pitch as a combination of Note messages and Pitch Bend messages. This means that if only the Note messages are examined on the sequencer's microscope (event list) screen, the on-screen information may differ from what is actually performed.
→ If continuous pitch change is not required, you can create data that is displayed more faithfully by setting the sending Bend Range to "0."

Specifications

Guitar Synthesizer GR-30

- **sound generator**

1 Part (Mono mode M=6/Poly mode switchable)

- **Maximum Polyphony**

28 voices

- **Memory**

System Setup 1
Tones 384
User Patches 128 (The initial settings are the same as the Preset Patches)
Preset Patches 128

- **Effects**

Reverb 1
Chorus 1

- **Display**

7 segments 3 characters LED

- **Connectors/Jacks**

Mix Out Jacks L and R (also serve as two stereo phone jacks)
Guitar Out Jack
Guitar Return Jack
Bank Shift Jack
Expression Pedal Jack
GK IN Connector
MIDI Connector (IN, OUT)
AC Adaptor Jack

- **Power Supply**

DC 9 V (AC Adaptor)

- **Current Draw**

440 mA

- **Dimensions**

302 (W) × 274 (D) × 58 (H) mm
11-15/16 (W) × 10-13/16 (D) × 2-5/16 (H) inches

- **Weight**

1.6 kg
3 lbs 9 oz (excluding the AC Adaptor)

- **Accessories**

Owner's Manual
AC Adaptor
GK Connecting Cable (C-13A, 5 m)

- **Options**

Synthesizer Driver GK-2A
GK Connecting Cable (C-13B, 10 m)

** In the interest of product improvement, the specifications and/or appearance of this unit are subject to change without prior notice.*

Roland Exclusive Messages

1. Data Format for Exclusive Messages

Roland's MIDI implementation uses the following data format for all Exclusive messages (type IV):

Byte	Description
F0H	Exclusive Status
41H	Manufacturer ID (Roland)
DEV	Device ID
MDL	Model ID
CMD	Command ID
[BODY]	Main data
F7H	End of exclusive

•MIDI status: F0H, F7H

An Exclusive message must be flanked by a pair of status codes, starting with a Manufacturer ID immediately after F0H (MIDI version 1.0).

•Manufacturer ID: 41H

The Manufacturer ID identifies the manufacturer of a MIDI instrument that sends an Exclusive message. Value 41H represents Roland's Manufacturer ID.

•Device ID: DEV

The Device ID contains a unique value that identifies individual devices in the implementation of several MIDI instruments. It is usually set to 00H–0FH, a value smaller by one than that of a basic channel, but value 00H–1FH may be used for a device with several basic channels.

•Model ID: MDL

The Model ID contains a value that identifies one model from another. Different models, however, may share an identical Model ID if they handle similar data.

The Model ID format may contain 00H in one or more places to provide an extended data field. The following are examples of valid Model IDs, each representing a unique model.

01H
02H
03H
00H, 01H
00H, 02H
00H, 00H, 01H

•Command ID: CMD

The Command ID indicates the function of an Exclusive message. The Command ID format may contain 00H in one or more places to provide an extended data field. The following are examples of valid Command IDs, each representing a unique function:

01H
02H
03H
00H, 01H
00H, 02H
00H, 00H, 01H

•Main data: BODY

This field contains a message to be exchanged across an interface. The exact data size and content will vary with the Model ID and Command ID.

2. Address-mapped Data Transfer

Address mapping is a technique for transferring messages conforming to the data format given in Section 1. It assigns a series of memory-resident records—waveform and tone data, switch status, and parameters, for example, to specific locations in a machine-dependent address space, thereby allowing access to data residing at the address a message specifies.

Address-mapped data transfer is therefore independent of models and data categories. This technique allows use of two different transfer procedures: one-way transfer and handshake transfer.

•One-way transfer procedure (See Section 3 for details.)

This procedure is suited to the transfer of a small amount of data. It sends out an Exclusive message completely independent of the receiving device's status.

Connection Diagram

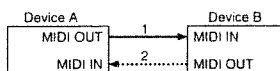

Connection at point 2 is essential for "Request data" procedures. (See Section 3.)

•Handshake-transfer procedure (This device does not use this procedure)

This procedure initiates a predetermined transfer sequence (handshaking) across the interface before data transfer takes place. Handshaking ensures that reliability and transfer speed are high enough to handle a large amount of data.

Connection Diagram

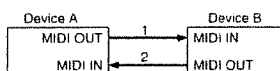

Connection at points 1 and 2 is essential.

Notes on the above procedures

- There are separate Command IDs for different transfer procedures.
- Devices A and B cannot exchange data unless they use the same transfer procedure, share identical Device ID and Model ID, and are ready for communication.

3. One-way Transfer Procedure

This procedure sends out data until it has all been sent and is used when the messages are so short that answerbacks need not be checked.

For longer messages, however, the receiving device must acquire each message in time with the transfer sequence, which inserts 20 milliseconds intervals.

Types of Messages

Message	Command ID
Request data 1	RQ1 (11H)
Data set 1	DT1 (12H)

•Request data #1: RQ1 (11H)

This message is sent out when there is a need to acquire data from a device at the other end of the interface. It contains data for the address and size that specify designation and length, respectively, of data required.

On receiving an RQ1 message, the remote device checks its memory for the data address and size that satisfy the request.

If it finds them and is ready for communication, the device will transmit a "Data set 1 (DT1)" message, which contains the requested data. Otherwise, the device won't send out anything.

Byte	Description
F0H	Exclusive Status
41H	Manufacturer ID (Roland)
DEV	Device ID
MDL	Model ID
11H	Command ID
aaH	Address MSB
	LSB
seH	Size MSB
	LSB
sum	Check sum
F7H	End of exclusive

- The size of the requested data does not indicate the number of bytes that will make up a DT1 message, but represents the address fields where the requested data resides.
- Some models are subject to limitations in data format used for a single transaction. Requested data, for example, may have a limit in length or must be divided into predetermined address fields before it is exchanged across the interface.
- The same number of bytes comprises address and size data, which, however, vary with the Model ID.
- The error-checking process uses a checksum that provides a bit pattern where the last 7 bits are zero when values for an address, size, and that checksum are summed.

•Data set 1: DT1 (12H)

This message corresponds to the actual data transfer process. Because every byte in the data is assigned a unique address, a DT1 message can convey the starting address of one or more bits of data as well as a series of data formatted in an address-dependent order.

The MIDI standards inhibit non real-time messages from interrupting an Exclusive one. This fact is inconvenient for devices that support a "soft-thru" function. To maintain compatibility with such devices, Roland has limited the DT1 to 256 bytes so that an excessively long message is sent out in separate 'segments'.

Byte	Description
FOH	Exclusive Status
41H	Manufacturer ID (Roland)
DEV	Device ID
MDL	Model ID
12H	Command ID
aaH	Address MSB
	LSB
ddH	Data MSB
	LSB
sum	Check sum
F7H	End of exclusive

- A DT1 message is capable of providing only the valid data among those specified by an RQ1 message.
- Some models are subject to limitations in data format used for a single transaction. Requested data, for example, may have a limit in length or must be divided into predetermined address fields before it is exchanged across the interface.
- The number of bytes comprising address data varies from one Model ID to another.
- The error-checking process uses a checksum that provides a bit pattern where the last 7 bits are zero when values for an address, size, and that checksum are summed.

•Example of Message Transactions

•Device A sending data to Device B

Transfer of a DT1 message is all that takes place.

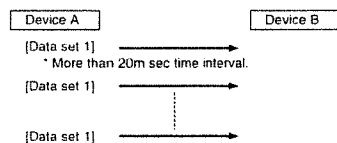

•Device B requesting data from Device A

Device B sends an RQ1 message to Device A. Checking the message, Device A sends a DT1 message back to Device B.

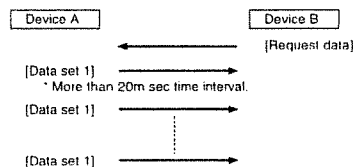

MIDI Implementation

Version 1.00 Oct.04, 1996

1. Recognized Receive Data

■ Channel Voice Message

● Note Off

STATUS	SECOND	THIRD
8nH	kkH	vvH
9nH	kkH	00H

n=MIDI Channel Number :0H - FH (0 - 15) 0=ch.1 15=ch.16
kk=Note Number :00H - 7FH (0 - 127)
vv=Velocity :ignored

● Note On

STATUS	SECOND	THIRD
9nH	kkH	vvH

n=MIDI Channel Number :0H - FH (0 - 15) 0=ch.1 15=ch.16
kk=Note Number :00H - 7FH (0 - 127)
vv=Velocity :01H - 7FH (1 - 127)

● Control Change

○ Bank Select

STATUS	SECOND	THIRD
BnH	00H	mmH

n=MIDI Channel Number :0H - FH (0 - 15) 0=ch.1 15=ch.16
mm=Bank Number :00H,01H

- The LSB of Bank Select is ignored.
- Can be received only through the Basic channel.

○ Modulation

STATUS	SECOND	THIRD
BnH	01H	vvH

n=MIDI Channel Number :0H - FH (0 - 15) 0=ch.1 15=ch.16
vv=Modulation Depth :00H - 7FH (0 - 127)

- Can be received only through the Basic channel.

○ Foot Type

STATUS	SECOND	THIRD
BnH	04H	vvH

n=MIDI Channel Number :0H - FH (0 - 15) 0=ch.1 15=ch.16
vv=Control Value :00H - 7FH (0 - 127)

- Can be received only through the Basic channel.

○ Volume

STATUS	SECOND	THIRD
BnH	07H	vvH

n=MIDI Channel Number :0H - FH (0 - 15) 0=ch.1 15=ch.16
vv=Volume :00H - 7FH (0 - 127)

- Can be received only through the Basic channel.

○ Pan

STATUS	SECOND	THIRD
BnH	0AH	vvH

n=MIDI Channel Number :01H - FH (0 - 15) 0=ch.1 15=ch.16
vv=Pan :00H - 40H - 7FH (0 - 127)

- Can be received only through the Basic channel.
- The value 0 is left, 64 is center, and 127 is right.

○ General Purpose #3

STATUS	SECOND	THIRD
BnH	12H	vvH

n=MIDI Channel Number :0H - FH (0 - 15) 0=ch.1 15=ch.16
vv=Control Value :001 - 7FH (0 - 127)

- Can be received Basic channel only when the "Play Feel" is set to EF1 or EF2, and recognized as the string envelope follow value.

○ General Purpose #4

STATUS	SECOND	THIRD
BnH	13H	vvH

n=MIDI Channel Number :0H - FH (0 - 15) 0=ch.1 15=ch.16
vv=Control Value :00H - 7FH (0 - 127)
0 = Reset,1-63=OFF,64-127=ON

- Can be received only through the Basic channel.
- Having received this message, the GR-30 acts as if the onboard WAH (foot switch) is operated.

○ Hold1

STATUS	SECOND	THIRD
BnH	40H	vvH

n=MIDI Channel Number :0H - FH (0 - 15) 0=ch.1 15=ch.16
vv=Control Value :00H - 7FH (0 - 127) 0-63=OFF,64-127=ON

- Can be received only through the Basic channel.
- Can be received only in the Poly receive Mode.

○ General Purpose #5

STATUS	SECOND	THIRD
BnH	50H	vvH

n=MIDI Channel Number :0H - FH (0 - 15) 0=ch.1 15=ch.16
vv=Control Value :00H - 7FH (0 - 127)
0-63=OFF,64-127=ON

- Can be received only through the Basic channel.
- Having received this message, the GR-30 acts as if the Tap Tempo pedal is operated.

○ General Purpose #6

STATUS	SECOND	THIRD
BnH	51H	vvH

n=MIDI Channel Number :0H - FH (0 - 15) 0=ch.1 15=ch.16
vv=Control Value :00H - 7FH (0 - 127)
0-63=OFF,64-127=ON

- Can be received only through the Basic channel.
- Having received this message, the Arpeggiator (or the Harmonist) is turned ON or OFF.

○ General Purpose #7

STATUS	SECOND	THIRD
BnH	52H	vvH

n=MIDI Channel Number :0H - FH (0 - 15) 0=ch.1 15=ch.16
vv=Control Value :00H - 7FH (0 - 127)
0-63=OFF,64-127=ON

- Can be received only through the Basic channel.
- Having received this message, the GR-30 acts as if the HOLD pedal is operated.

○ General Purpose #8

STATUS	SECOND	THIRD
BnH	53H	vvH

n=MIDI Channel Number :0H - FH (0 - 15) 0=ch.1 15=ch.16
vv=Control Value :00H - 7FH (0 - 127)
0-63=OFF,64-127=ON

- Can be received only through the Basic channel.
- Having received this message, the GR-30 acts as if the ARP/HAR pedal is operated when the Arpeggio is held

◻Effect 1 (Reverb Send Level)

STATUS	SECOND	THIRD
BnH	5BH	vvH

n=MIDI Channel Number :0H - FH (0 - 15) 0=ch.1 15=ch.16
vv=Control Value :00H - 7FH (0 - 127)

- Can be received only through the Basic channel.

●Program Change

STATUS	SECOND	THIRD
CnH	ppH	

n=MIDI Channel Number :0H - FH (0 - 15) 0=ch.1 15=ch.16
pp=Program Number :00H - 7FH (0 - 127) 0=PrG.1 127=PrG.128

- Can be received only through the Basic channel.
- The recognized Program Change number corresponds to each patch as follows.

<When the patches of group A, B, C or D are selected...>

1...4 = A11...A14	65...68 = C11...C14
5...8 = A21...A24	69...72 = C21...C24
9...12 = A31...A34	73...76 = C31...C34
13...16 = A41...A44	77...80 = C41...C44
17...20 = A51...A54	81...84 = C51...C54
21...24 = A61...A64	85...88 = C61...C64
25...28 = A71...A74	89...92 = C71...C74
29...32 = A81...A84	93...96 = C81...C84
33...36 = b11...b14	97...100 = d11...d24
37...40 = b21...b24	101...104 = d21...d34
41...44 = b31...b34	105...108 = d31...d34
45...48 = b41...b44	109...112 = d41...d44
49...52 = b51...b54	113...116 = d51...d54
53...56 = b61...b64	117...120 = d61...d64
57...60 = b71...b74	121...124 = d71...d74
61...64 = b81...b84	125...128 = d81...d84

- When you call the patches of the Group E,F,G or H, send the value "1" of the controller number 0 before the program change message sending.

<When the patches of group E, F, G or H are selected...>

1...4 = E11...E14	65...68 = G11...G14
5...8 = E21...E24	69...72 = G21...G24
9...12 = E31...E34	73...76 = G31...G34
13...16 = E41...E44	77...80 = G41...G44
17...20 = E51...E54	81...84 = G51...G54
21...24 = E61...E64	85...88 = G61...G64
25...28 = E71...E74	89...92 = G71...G74
29...32 = E81...E84	93...96 = G81...G84
33...36 = F11...F14	97...100 = H11...H24
37...40 = F21...F24	101...104 = H21...H24
41...44 = F31...F34	105...108 = H31...H34
45...48 = F41...F44	109...112 = H41...H44
49...52 = F51...F54	113...116 = H51...H54
53...56 = F61...F64	117...120 = H61...H64
57...60 = F71...F74	121...124 = H71...H74
61...64 = F81...F84	125...128 = H81...H84

- When you call the patches of the Group A,B,C or D, send the value "0" of the controller number 0 before the program change message sending.

●Pitch Bend Change

STATUS	SECOND	THIRD
EnH	iiH	mmH

n=MIDI Channel Number :0H - FH (0 - 15) 0=ch.1 15=ch.16
mm,ii=Value :00H,00H - 7FH,7FH (-8192 - +8191)

■Channel Mode Message

●All Note Off

STATUS	SECOND	THIRD
BnH	7BH	00H

n=MIDI Channel Number :0H - FH (0 - 15) 0=ch.1 15=ch.16

- Can be received only through the Basic channel.
- Turn off all notes that are now on.

●OMNI OFF

STATUS	SECOND	THIRD
BnH	7CH	00H

n=MIDI Channel Number :0H - FH (0 - 15) 0=ch.1 15=ch.16

- Can be received only through the Basic channel.
- Will act the same as All Note Off.

●OMNI ON

STATUS	SECOND	THIRD
BnH	7DH	00H

n=MIDI Channel Number :0H - FH (0 - 15) 0=ch.1 15=ch.16

- Can be received only through the Basic channel.
- Will act the same as All Note Off.

●MONO

STATUS	SECOND	THIRD
BnH	7EH	mmH

n=MIDI Channel Number :0H - FH (0 - 15) 0=ch.1 15=ch.16
mm=Number of Individual Channels ignored

- Can be received only through the Basic channel.
- Will act the same as All Note Off.

●POLY

STATUS	SECOND	THIRD
BnH	7FH	00H

n=MIDI Channel Number :0H - FH (0 - 15) 0=ch.1 15=ch.16

- Can be received only through the Basic channel.
- Will act the same as All Note Off.

■System Realtime Message

●Active Sensing

STATUS
FEH

- Having received this message, GR-30 expects to receive information of any status of data during about 420msec. If GR-30 doesn't receive any message during that time, it acts as if the All Note Off message is received, and returns to normal operation (will not check interval of messages).

●Timing Clock

STATUS
F8H

- Can be received only when the A-TEMPO is set to "Syn".

●Start

STATUS
FAH

- Can be received only when the A-TEMPO is set to "Syn" and the realtime recording of arpeggiator is ready.

●Continue

STATUS
FBH

- Can be received only when the A-TEMPO is set to "Syn" and the realtime recording of arpeggiator is ready.

●Stop

STATUS
FCH

- Can be received only when the A-TEMPO is set to "Syn" and the realtime recording of arpeggiator is ready.

■System Exclusive Message

STATUS	DATA BYTES
F0H	iiH ddHeeH
F7H	

F0H :System Exclusive
ii = Manufacturer ID :41H (65)
ddee = Data :00H - 7FH (0 - 127)
F7H :EOX (End of Exclusive)

- Refer to Section 3, 4, and the pages of "Roland Exclusive Message" for more detailed information.

2. Transmitted Data

■ Channel Voice Message

● Note Off

STATUS	SECOND	THIRD
9nH	kkH	00H

n=MIDI Channel Number :0H - FH (0 - 15) 0=ch.1 15=ch.16
 kk=Note Number :00H - 7FH (0 - 127)

● Note On

STATUS	SECOND	THIRD
9nH	kkH	vvH

n=MIDI Channel Number :0H - FH (0 - 15) 0=ch.1 15=ch.16
 kk=Note Number :00H - 7FH (0 - 127)
 vv=Velocity :01H - 7FH (1 - 127)

● Control Change

○ Bank Select

STATUS	SECOND	THIRD
BnH	00H	mmH
BnH	20H	llH

n=MIDI Channel Number :0H - FH (0 - 15) 0=ch.1 15=ch.16
 mm,ll=Bank Number :00H,00H - 7FH,7FH (bank1-bank16384)

○ Modulation

STATUS	SECOND	THIRD
BnH	01H	vvH

n=MIDI Channel Number :0H - FH (0 - 15) 0=ch.1 15=ch.16
 vv=Modulation Depth :00H - 7FH (0 - 127)

○ Foot Type

STATUS	SECOND	THIRD
BnH	04H	vvH

n=MIDI Channel Number :0H - FH (0 - 15) 0=ch.1 15=ch.16
 vv=Control Value :00H - 7FH (0 - 127)

* When the Expression Pedal is operated, the GR-30 sends this as the operation (except some noted setting of the "EXP PEDAL" parameter).

○ Data Entry

STATUS	SECOND	THIRD
BnH	0nH	mmH
BnH	2nH	llH

n=MIDI Channel Number :0H - FH (0 - 15) 0=ch.1 15=ch.16
 mm,ll= Value for the parameter that is selected by RPN.

○ Volume

STATUS	SECOND	THIRD
BnH	07H	vvH

n=MIDI Channel Number :0H - FH (0 - 15) 0=ch.1 15=ch.16
 vv=Volume :00H - 7FH (0 - 127)

* Transmitted the total volume fixed with expression pedal and GK-2A's operation.

○ Pan

STATUS	SECOND	THIRD
BnH	0AH	vvH

n=MIDI Channel Number :0H - FH (0 - 15) 0=ch.1 15=ch.16
 vv=Pan :00H - 40H - 7FH (0 - 64 - 127)

* The value 0 is left, 64 is center, and 127 is right.

* Transmitted the action of the expression pedal when the "EXP PEDAL" is set to "L-R".

○ General Purpose #3

STATUS	SECOND	THIRD
BnH	12H	vvH

n=MIDI Channel Number :0H - FH (0 - 15) 0=ch.1 15=ch.16
 vv=Control Value :00H - 7FH (0 - 127)

* Transmitted the envelope data of the strings when the "PLAY FEEL" is set to EF1 or EF2

○ General Purpose #4

STATUS	SECOND	THIRD
BnH	13H	vvH

n=MIDI Channel Number :0H - FH (0 - 15) 0=ch.1 15=ch.16
 vv=Control Value :00H - 7FH (0 - 127)
 0 = Reset, 1-63=OFF, 64-127=ON

* Transmitted the operation of onboard WAH function (Pedal 1).

○ General Purpose #6

STATUS	SECOND	THIRD
BnH	51H	vvH

n=MIDI Channel Number :0H - FH (0 - 15) 0=ch.1 15=ch.16
 vv=Control Value :00H - 7FH (0 - 127)
 0-63=OFF, 64-127=ON

* Transmitted the operation of turning Arpeggiator (or Harmonist) ON or OFF by "CTRL ARP/HAR" pedal.

○ General Purpose #7

STATUS	SECOND	THIRD
BnH	52H	vvH

n=MIDI Channel Number :0H - FH (0 - 15) 0=ch.1 15=ch.16
 vv=Control Value :00H - 7FH (0 - 127)
 0-63=OFF, 64-127=ON

* Transmitted the operation of onboard HOLD pedal.

○ General Purpose #8

STATUS	SECOND	THIRD
BnH	53H	vvH

n=MIDI Channel Number :0H - FH (0 - 15) 0=ch.1 15=ch.16
 vv=Control Value :00H - 7FH (0 - 127)
 0-63=OFF, 64-127=ON

* Transmitted the operation of "CTRL ARP/HAR" pedal when the Arpeggio is held.

○ Effect 1 (Reverb Send Level)

STATUS	SECOND	THIRD
BnH	5BH	vvH

n=MIDI Channel Number :0H - FH (0 - 15) 0=ch.1 15=ch.16
 vv=Control Value :00H - 7FH (0 - 127)

* Transmitted the action of the expression pedal when the "EXP PEDAL" is set to "REL".

○ RPN MSB/LSB

STATUS	SECOND	THIRD
BnH	65H	mmH
BnH	64H	llH

n=MIDI Channel Number :0H - FH (0 - 15) 0=ch.1 15=ch.16
 mm=Upper byte of the parameter data designated by RPN.
 ll=Lower byte of the parameter data designated by RPN.

RPN

Control change includes RPNs (registered parameter number), function which are defined by the MIDI standard. Each RPN may be used to change parameters of equipment. To effect RPN, first designate the parameter to be controlled using RPN MSB and RPN LSB, and then specify the value of designated parameter in the data entry. The GR-30 can transmit only one RPN: pitch bend sensitivity (RPN#0).

RPN	Data entry	Function
MSB_LSB	MSB_LSB	pitch bend sensitivity (The transmitted lower byte is always 00H.)
0CH 00H	mmH, 00H	

● Program Change

STATUS	SECOND
CnH	ppH

n=MIDI Channel Number :0H - FH (0 - 15) 0=ch.1 15=ch.16
 pp=Program Number :00H - 7FH (0 - 127)

● Pitch Bend Change

STATUS	SECOND	THIRD
EnH	llH	mmH

n=MIDI Channel Number :0H - FH (0 - 15) 0=ch.1 15=ch.16
 mm,ll=Value :00H,00H - 7FH,7FH (-8192 - +8191)

■ System Realtime Message

● Active Sensing

STATUS
F7H

- * This message is always transmitted during about 270msec.

■ System Exclusive Message

STATUS DATA BYTES
F0H iiH,ddH,...,eeH
F7H

F0H :System Exclusive
ii=Manufacturer ID :41H (65)
dd,...,ee=Data :00H-7FH (0-127)
F7H :EOX (End of Exclusive/System Common Message)

- * Refer to Section 3, 4, and the pages of "Roland Exclusive Message" for more detailed information.

3. Exclusive Communications

The GR-30 can transmit (or receive) system and patches parameters using system exclusive messages.

Model ID of GR-30 is 00H 07H.

Device ID of GR-09 is fixed at 10H.

● Request Data 1: RQ1 (11H)

This message is to request the GR-30 to transmit its parameters.
The GR-30 itself does not send this message.

When the GR-30 receives this message, it responds with appropriate parameters if the following conditions are satisfied:

1. The addresses indicated with RQ1 matches with one of the parameter base address of the GR-30.
2. The requested size is larger than 1.

With these conditions provided, the GR-30 transmits specified parameters in Data Set 1 (DT1) message. RQ1 structure is shown below.

Bytes	Comments
F0H	System exclusive status
41H	Manufacturer ID (Roland)
10H	Device ID (Dev=10H)
00H	Model ID (GR-30)
07H	Model ID (GR-30)
11H	Command ID (RQ1)
aaH	Address MSB
bbH	Address
ccH	Address
ddH	Address LSB
ssH	Size MSB
ssH	Size
ssH	Size
ssH	Size LSB
sum	Check sum byte
F7H	EOX (End Of Exclusive)

● Data Set 1: DT1 (12H)

- * Having received this message, GR-30 acts as follows.

If the address matches with one of the parameter base addresses of the GR-30, the received data is stored at the specified address of the memory.

- * The GR-30 transmits this message in the following conditions.

1. When the GR-30 responds to RQ1 message.
2. The user executes Bulk Dump function.

Regarding details of the parameters, please refer to the parameter address map.
The DT1 structure is shown below.

Bytes	Comments
F0H	System exclusive status
41H	Manufacturer ID (Roland)
10H	Device ID (Dev=10H)
00H	Model ID (GR-30)
07H	Model ID (GR-30)
12H	Command ID (DT1)
aaH	Address MSB
bbH	Address
ccH	Address
ddH	Address LSB
eeH	Data
.	.
ffH	Data
sum	Check sum byte
F7H	EOX (End Of Exclusive)

○ Model ID

The model ID of GR-30 is 00H 07H.

○ Device ID

Device ID of GR-30 is fixed at 10H.

/ Example of creating the exclusive message /

If you wish to change the current Reverb Type to room2, create data as the following and send it to your GR-30.

```
F0H 41H 10H 00H 07H 12H 02H 00H 00H 1EH 02H 63H F7H
  1   2   3   4   5       6       7   8   9
```

1. F0H is the exclusive status.
2. 41H is the Roland's manufacturer ID.
3. This is the device ID. (Fixed at 10H for GR-30.)
4. 00H 07H is the model ID of the GR-30.
5. 12H is DT1 (data set) command ID.
6. These are the parameter addresses of the Reverb Type.

Please find the start address of the temporary Patch from the table of the parameter Address Block. You can find the address as "02H 00H 00H 00H".

Next, please find the offset address of the Reverb Type from the table 4-2. That is 00H 00H 1EH. And add these address values. The result will be 02H 00H 00H 1EH.

```
02H 00H 00H 00H (the start address of the temporary patch)
+) 00H 00H 1EH (the offset address of the Reverb Type)
-----
02H 00H 00H 1EH
```

7. Please find the Reverb Type value of "Room2". That is 2(= 02H, see A-1).

8. This is the check sum byte. The error checking process uses a Checksum and provides a pattern where the last significant 7 bits are zero when values for an address, data(or size) and the Checksum are summed.

If the address is "aa bb cc ddH" and the data (or the size) is "ee ff hh iiH"

$$aa + bb + cc + dd + ee + ff + hh + ii = \text{sum}$$

$$\text{sum} / 128 = \text{quotient} \dots \text{remainder}$$

$$128 - \text{remainder} = \text{checksum}$$

In case of this example,

```
F0H 41H 10H 00H 07H 12H 02H 00H 00H 1EH 02H 63H F7H
          address      data  checksum
```

Using the above formula, Checksum will be as follows.

$$02H + 00H + 00H + 1EH + 02H = 2 + 0 + 0 + 30 + 2 = 34(\text{sum})$$

$$34(\text{sum}) / 128 = 0(\text{quotient}) \dots 34(\text{remainder})$$

$$\text{checksum} = 128 - 34(\text{remainder}) = 94 = 5EH$$

If you calculate with hexadecimal,

$$aa + bb + cc + dd + ee + ff = \text{sum}(xxH)$$

$$\text{sum}(xxH) / 80H = \text{quotient} \dots \text{remainder}$$

$$80H - \text{remainder} = \text{checksum}$$

Checksum will be as follows.

$$02H + 00H + 00H + 1EH + 02H = 22H$$

$$22H / 80H = 00H(\text{quotient}) \dots 22H(\text{remainder})$$

$$\text{checksum} = 80H - 22H(\text{remainder}) = 5EH$$

9. F7H is the mark of the end of exclusive.

4. Parameter Address Map

Addresses and sizes are expressed in 7-bit hexadecimal values.

Address	MSB	0aaa aaaa	0bbb bbbb	0ccc cccc	LSB	0ddd dddd
Binary		AA	BB	CC		DD
7 bit Hex						
Address	MSB	0sss ssss	0ttt tttt	0uuu uuuu	LSB	0vvv vvvv
Binary		SS	TT	UU		VV
7 bit Hex						

Parameter Address Block

Start address	Contents and remarks	
00 00 00 00	System Area	*4-1
01 00 00 00	Patch All	*4-2
01 7F 00 00	Patch D84	
02 00 00 00	Temporary Patch	*4-2
03 00 00 00	Patch All Arpeggiator Data	*4-3
03 7F 00 00	Patch D84 Arpeggiator Data	
04 00 00 00	Temporary Patch Arpeggiator Data	*4-3

*4-1 System Area

Offset address	Data	Contents and remarks
00 00 00	0000 - 017F	Master Tune LSB 427.2-452.7Hz Master Tune MSB (+/-50cent) 0000H = 427.2Hz 0100H = 440.0Hz 017FH = 452.7Hz
00 00 02	00 - 1A	Basic Channel MONG 1-11, POLY 1-16
00 00 03	00 - 07	Bend Range 0,1,2,4,5,7,12,24
00 00 04	00 - 01	Bank Select Send Switch OFF,ON
00 00 05	00 - 01	Bend Range Request Send Switch OFF,ON
00 00 06	00 - 01	Volume Send Switch OFF,ON
00 00 07	00 - 01	Effect Bypass Switch OFF,ON
00 00 08	00 - 01	Patch Number Display Type GBN,dec
00 00 09	00 - 03	Guitar (string sense) Select 1-4
00 00 0A	00 - 07	String Sense 1 (string #1) 1-8 String Sense 1 (string #6)
00 00 0F		
00 00 10	00 - 07	String Sense 2 (string #1) 1-8 String Sense 2 (string #6)
00 00 15		
00 00 16	00 - 07	String Sense 3 (string #1) 1-8 String Sense 3 (string #6)
00 00 1B		
00 00 1C	00 - 07	String Sense 4 (string #1) 1-8 String Sense 4 (string #6)
00 00 21		

/ Example using RQ1 /

To extract all the system parameters from the GR-30, send the following message to the GR-30.

F0 41 10 00 07 11 00 00 00 00 00 22 5E F7

/ Example using DT1 /

To change the Bend Range to 12, send the following message to the GR-30.

F0 41 10 00 07 12 00 00 03 06 77 F7

*4-2 Patch

Offset address	Data	Contents and remarks
00 00 00	00 - 64	Patch Level 0-100
00 00 01	0E - 72	Tone Balance -50 - +50 [*2]
00 00 02	00 - 05	Layer Type (string #1) Type 1-6 Layer Type (string #6)
00 00 07		
00 00 08	0000 - 017F	Tone Number LSB (1st Tone) 1-384 MSB [*1][*15]
00 00 09		
00 00 0A	0E - 72	Attack (1st Tone) -50 - +50 [*2]
00 00 0B	0E - 72	Release (1st Tone) -50 - +50 [*2]
00 00 0C	0E - 72	Brightness (1st Tone) -50 - +50 [*2]
00 00 0D	1C - 58	Transpose (1st, string #1) -36 - +24 Transpose (1st, string #6) [*2]
00 00 12		
00 00 13	0000 - 017F	Tone Number LSB (2nd Tone) 1-384 MSB [*1][*15]
00 00 14		
00 00 15	0E - 72	Attack (2nd Tone) -50 - +50 [*2]
00 00 16	0E - 72	Release (2nd Tone) -50 - +50 [*2]
00 00 17	0E - 72	Brightness (2nd Tone) -50 - +50 [*2]
00 00 18	1C - 58	Transpose (2nd, string #1) -36 - +24 Transpose (2nd, string #6) [*2]
00 00 1D		
00 00 1E	00 - 12	Reverb Type [*3]
00 00 1F	00 - 64	Reverb Level 0-100
00 00 20	00 - 64	Reverb Time 0-100
00 00 21	00 - 19	Chorus Type [*4]
00 00 22	00 - 01	Arpeggiator/Harmony Switch OFF,ON
00 00 23	00 - 0D	Arpeggiator/Harmony Type [*5]
00 00 24	00 - 08	Arpeggiator Rhythm [*6]
00 00 25	00 - 09	Arpeggiator Duration [*7]
00 00 26	0000 - 00C9	Arpeggiator LSB EXT-Sync, 50-250 Tempo MSB [*15]
00 00 27		
00 00 28	00 - 17	Harmony Key C,C#...B,Cm,C#m...Bm
00 00 29	00 - 0B	Harmony Style [*8]
00 00 2A	00 - 11	Glide Type down 9-1, up 1-9
00 00 2B	00 - 23	Wah Type [*9]
00 00 2C	00 - 0E	Hold Type [*10]
00 00 2D	00 - 03	Arp. Hold Type Dmp, Sus, Latch A, B
00 00 2E	00 - 4E	EV-5 Assign [*11]
00 00 2F	00 - 0F	Play Feel [*12]
00 00 30	0E - 7C	Panpot [*13]
00 00 31	00 - 02	Chromatic OFF, ON1, ON2
00 00 32	00 - 3F	MIDI send switch [*14]
00 00 33	00 - 7F	MIDI program change (string 1) 1-128
00 00 38		MIDI program change (string 6)
00 00 39	00 - 00	not use
00 00 3A	00 - 7F	Bank Select LSB (string 1) 1-128
00 00 3F		Bank Select LSB (string 6)
00 00 40	00 - 00	not use
00 00 41	00 - 7F	Bank Select MSB (string 1) 1-128
00 00 46		Bank Select MSB (string 6)
00 00 47	1C - 58	Transpose (MIDI, string #1) -36 - +24 Transpose (MIDI, string #6) [*2]
00 00 4C		
00 00 4D	00 - 01	Harmony Key Remote Switch OFF, ON
00 00 4E	00 - 00	not use
00 00 4F	00 - 00	not use

[*1]: 0000H = Tone #1, 007FH = Tone #128, 0100H = Tone #129, 027FH = Tone #384

[*2]: 40H = +0

[*3]: Off, Room 1-3, Hall 1-2, Plate, Delay 1-6, Panning Delay 1-6

[*4]: Off, Chorus 1-9, Flanger 1-8, Short Delay 1-6, SE 1-2

[*5]: Arp, A-1, A-2, A-b, A-E, A-1E, A-2E, hAr, h-1, h-2, h-b, h-E, h-1E, h-2E

[*6]: 1/4 straight, 1/8 straight, 1/8 light shuffle, 1/8 heavy shuffle, 1/8 (3), 1/16 straight, 1/16 light shuffle, 1/16 heavy shuffle, 1/16 (3)

[*7]: 30%, 40%, 50%, 60%, 70%, 80%, 90%, 100%, 120%, Full

[*8]: -7th, -6th, -5th, -4th, -3rd, -2nd, +2nd, +3rd, +4th, +5th, +6th, +7th, diminish

[*9]: wah 1-5, auto wah 1-5, brightness 1-5,narrow wah 1-5, reverse wah 1-5. reverse
brightness 1-5,reverse narrow wah 1-5, modulation
[*10]: Damper 12E,1,2,12,E,1E,2E, Sostenuo 12E,1,2,12,E,1E,2E, string
[*11]: volume, add 1st,add 2nd,balance,brightness,wah,pitch,modulation, L<-
>R,pan,reverber send,tempo1,tempo2,tempo3,tempo&pitch, Control Change #1-32,64-95
[*12]: (standard) normal,finger,hard,soft,tapping,no dynamics,envolve follow 1,2
(accelerator .ON) normal,finger,hard,soft,tapping,no dynamics,envolve follow 1,2
[*13]: -50 - +50,1-6,6-1,O-E,E-O,random,random_1st,random_2nd,alternate,
alternate_1st,alternate_2nd
[*14]: bit 0 = string 1,...bit 5 = string 6. 1 is on, 0 is off.
[*15]: 2 byte continuance data.(MSB + LSB)

/ Example using RQ1 /

To extract the all parameters' value of the patch "A12", send the following message to the GR-30.

```
F0 41 10 00 07 11 01 01 00 00 00 00 00 50 2E F7
```

/ Example using DT1 /

To change the Brightness of temporary patch to +10, send the following message to the GR-30.

```
F0 41 10 00 07 12 02 00 00 0C 4A 28 F7
```

*4-3 Arpeggiator Data

Offset address	Data	Contents and remarks
00 00 00	00 - 20	step 0-32
00 00 01	00 - 1F	step data (step1,string #1) [*1]
00 00 02		step data (step1,string #2)
00 00 03		step data (step1,string #3)
00 00 04		step data (step1,string #4)
00 00 05		step data (step1,string #5)
00 00 06		step data (step1,string #6)
00 00 07		step data (step2,string #1)
00 00 08		step data (step2,string #2)
:	:	:
00 01 40		step data (step32,string #6)

[*1] if bit4 is 1, tie of this step is on.

00 no data
01-0F ... velocity 1 to 15 and tie is off.
10 tie only.
11-1F ... velocity 1 to 15 and tie is on.

●A-1 Decimal VS Hexadecimal

With a MIDI system the data value, the address, or size in an exclusive message is expressed in 7bit hexadecimal values. The table below shows decimal value and their hexadecimal counterparts.

Decimal	Hex	Decimal	Hex	Decimal	Hex	Decimal	Hex
0	00H	32	20H	64	40H	96	60H
1	01H	33	21H	65	41H	97	61H
2	02H	34	22H	66	42H	98	62H
3	03H	35	23H	67	43H	99	63H
4	04H	36	24H	68	44H	100	64H
5	05H	37	25H	69	45H	101	65H
6	06H	38	26H	70	46H	102	66H
7	07H	39	27H	71	47H	103	67H
8	08H	40	28H	72	48H	104	68H
9	09H	41	29H	73	49H	105	69H
10	0AH	42	2AH	74	4AH	106	6AH
11	0BH	43	2BH	75	4BH	107	6BH
12	0CH	44	2CH	76	4CH	108	6CH
13	0DH	45	2DH	77	4DH	109	6DH
14	0EH	46	2EH	78	4EH	110	6EH
15	0FH	47	2FH	79	4FH	111	6FH
16	10H	48	30H	80	50H	112	70H
17	11H	49	31H	81	51H	113	71H
18	12H	50	32H	82	52H	114	72H
19	13H	51	33H	83	53H	115	73H
20	14H	52	34H	84	54H	116	74H
21	15H	53	35H	85	55H	117	75H
22	16H	54	36H	86	56H	118	76H
23	17H	55	37H	87	57H	119	77H
24	18H	56	38H	88	58H	120	78H
25	19H	57	39H	89	59H	121	79H
26	1AH	58	3AH	90	5AH	122	7AH
27	1BH	59	3BH	91	5BH	123	7BH
28	1CH	60	3CH	92	5CH	124	7CH
29	1DH	61	3DH	93	5DH	125	7DH
30	1EH	62	3EH	94	5EH	126	7EH
31	1FH	63	3FH	95	5FH	127	7FH

* When expressing a MIDI channel number or a program change number, please notice that the values are less by one. For example, MIDI channel is expressed as 0 through 15 instead of 1 through 16.

* The range of 7 bit can express 128 steps from 0 to 127. To express broader range, use several data bytes.

MIDI Implementation Chart

Function...		Transmitted	Recognized	Remarks
Basic Channel	Default Changed	1 — 16 1 — 16	1 — 16 1 — 16	* 1
Mode	Default Messages Altered	Mode 3, 4 (M=6) *1 X *****	Mode 3, 4 (M=6) X	
Note Number :	True Voice	0 — 127 *****	0 — 127	
Velocity	Note ON Note OFF	O 9n v=1—127 X 9n v=0	O X	
After Touch	Key's Ch's	X X	X X	
Pitch Bend		O	O	
Control Change	0, 32	O	O (MSB Only)	Bank select
	1	O	O	Modulation *2
	4	O	O	Foot type *2
	6, 38	O	O	Data entry
	7	O	O	Volume *2
	10	O	O	Pan *2
	18	O	O	(General Purpose 3)
	19	O	O	(General Purpose 4) *2
	64	x	O	Hold 1 *3
	80	x	O	(General Purpose 5) *2
	81	O	O	(General Purpose 6) *2
	82	O	O	(General Purpose 7) *2
	83	O	O	(General Purpose 8) *2
	91	O	O	EFFECT 1 (Reverb) *2
100, 101	O	x	RPN LSB, MSB	
	1—32, 64—95	O	— (†)	Assignable (EXP PEDAL)
Program Change	: True # *****	O	O	*2
System Exclusive		O	O	
System Common	: Song Pos : Song Sel : Tune	X X X	X X X	
System Real Time	: Clock : Commands	X X	O O	
Aux Message	: Local ON/OFF : All Notes OFF : Active Sense : System Reset	X X O X	X O (123 — 127) O X	*2
Notes	* 1 Can be memorized after powering off. * 2 Can be received only through the Basic channel. * 3 Can be received only in the POLY MODE (MODE 3) reception.			

Mode 1 : OMNI ON, POLY
Mode 3 : OMNI OFF, POLY

Mode 2 : OMNI ON, MONO
Mode 4 : OMNI OFF, MONO

O : Yes
X : No

Parameter List (Blank Chart)

You may photocopy this page and use it to make notes as you edit patches.

PATCH parameters

PATCH =

--

1ST TONE

TONE# = [] (1-384)
ATTACK = [] (-50-0-50)
RELEASE = [] (-50-0-50)
BRIGHTNESS = [] (-50-0-50)

STONE MIX

LAYER=	ALL	STRINGS					
		1st	2nd	3rd	4th	5th	6th
mute		mute	mute	mute	mute	mute	mute
1st		1st	1st	1st	1st	1st	1st
2nd		2nd	2nd	2nd	2nd	2nd	2nd
both		both	both	both	both	both	both
det.weak		det.weak	det.weak	det.weak	det.weak	det.weak	det.weak
det.strong		det.strong	det.strong	det.strong	det.strong	det.strong	det.strong

TRANS []	[]	[]	[]	[]	[]	[]	[]
1ST=							(-36-0-24)
TRANS []	[]	[]	[]	[]	[]	[]	[]
2ND=							(-36-0-24)
1:2 BAL = []	(-50-0-50)						

2ND TONE

TONE# = [] (1-384)
ATTACK = [] (-50-0-50)
RELEASE = [] (-50-0-50)
BRIGHTNESS = [] (-50-0-50)

ARPEGGIO/harmony

ARPEGGIO/harmony ON/OFF = on, off
ARPEGGIO <input type="checkbox"/> arpeggio <input type="checkbox"/> harmony
/harmony SEL = ARP/har, 1st, 2nd, both, EXT, 1st+EXT, 2nd+EXT
A-RHYTHM = 4, 8, 8L, 8H, 8t, 16, 16L, 16H, 16t
A-DURATION = 30, 40, 50, 60, 70, 80, 90, 100, 120, FULL
A-TEMPO = [] (50-250) / <input type="checkbox"/> sync
h-style = -7, -6, -5, -4, -3, -2, 2, 3, 4, 5, 6, 7, diminish
h-key = C, C#, D, D#, E, F, F#, G, G#, A, A#, B <input type="checkbox"/> Major <input type="checkbox"/> minor
h-remote = off, on

EFFECT

REVERB TYPE = off, room, hall, plate, [] (1-6)
delay, panning_delay
REVERB LEVEL = [] (0-100)
REV/DLY TIME = [] (0-100)
CHORUS TYPE = off, chorus, flanger, [] (1-9)
short_delay, special_effect

FOOT PEDAL

WAH TYPE = wah, auto_wah, brightness, narrow_wah, [] (1-5)
reverse_wah, reverse_auto_wah, reverse_brightness, reverse_narrow_wah, modulation
GLIDE TYPE = down, up [] (1-9)
HOLD TYPE = <input type="checkbox"/> damper <input type="checkbox"/> strings all, 1st, 2nd, both, <input type="checkbox"/> alpeggiator on
<input type="checkbox"/> sostenuto EXT, 1st+EXT, 2nd+EXT damper, sostenuto, latchA, latchB
EXP PEDAL = volume, add1st, add2nd, balance, brightness, wah, pitch, modulation, CONTROL CHANGE#
L-R, pan, reverb level, tempo1, tempo2, tempo3, tempo+pitch [] (1-32, 64-95)

COMMON

PATCH LEVEL = [] (0-100)
PLAY FEEL = normal, finger, hard, soft, <input type="checkbox"/> acceleration
tapping, no_dynamics, ef1, ef2
PAN = <input type="checkbox"/> [] (-50-0-50)
<input type="checkbox"/> 1-6, 6-1, O-E, E-O,
random_all, random_1st, random_2nd,
alternate_all, alternate_1st, alternate_2nd
CHROMATIC = off, on1, on2, on3

MIDI

PG CHANGE=	ALL	STRINGS					
		1st	2nd	3rd	4th	5th	6th
PG CHANGE= []	[]	[]	[]	[]	[]	[]	[]
CC#0 = []	[]	[]	[]	[]	[]	[]	[]
CC#32 = []	[]	[]	[]	[]	[]	[]	[]
TRANSPOSE= []	[]	[]	[]	[]	[]	[]	[]

SYSTEM parameters

MIDI CHANNEL = mono, poly [] (1-16)
BENDRANGE = 0, 1, 2, 3, 4, 5, 7, 12, 24
BEND RANGE REQUEST = off, on
MIDI BANK SELECT = off, on
PATCH DISPLAY MODE = Group_Bank_No, decimal
SEND CC#7 = off, on
MASTER TUNE = [4 _ _ _] (27.2-52.7)

PICK UP SENS

GUITAR SELECT	STRINGS					
	1st	2nd	3rd	4th	5th	6th
Gt 1 ()	[]	[]	[]	[]	[]	[]
Gt 2 ()	[]	[]	[]	[]	[]	[]
Gt 3 ()	[]	[]	[]	[]	[]	[]
Gt 4 ()	[]	[]	[]	[]	[]	[]

Index (WORDS/PANEL PRINT)

INDEX (WORDS)

A

Acceleration Function	38
Adaptor (AC ~)	10, 12
Alternate (PAN)	39
Arpeggiator	51
Turning the ~ On/Off	55
Creating Patterns	60
Duration (Staccato/Tenuto)	57
Rhythm (Selecting Notes and Rhythm)	58
Tempo (Setting/Syncing)	56
Tap Tempo	57
Hold Function for ~	53
Selecting Tones to Be Arpeggiated	55
ATTACK (TONE)	32
Assigning Patches Before Saving	30

B

Backup	31
~ to a Sequencer or Other MIDI Device	31
Blank Chart	99
Balance (Volume ~)	
Between 1ST TONE and 2ND TONE	35
Between PATCH and PATCH	36
Bank Select (MIDI ~)	73
MIDI Controller No.0	73
MIDI Controller No.32	73
Turn the Transmission of ~ On/Off	73
Bank (PATCH)	17
Bank Shift Pedal	19
Change the ~ of Patch (base Module/GK-2A)	19
Bending (Chromatic OFF)	40
Bend Data Thin	79
Bend Range	71
Bend Range Request	71, 84
Brightness	
Changing Tone Brightness	33
~ Control (Onboard Wah Pedal)	45
~ Control (Expression Pedal)	49
Bulk Dump	31

C

Change Group	19
Chorus	43
Chromatic	
Chromatic On/Off	40
Chromatic with External Sound Generators	40, 71
Click for Pattern Input	61
Computer (Sequencer) Connection	77
Connection 12	
to Stereo Amplifier	12
to Expression Pedal (EV-5)	49
to External Guitar Effecters	13
to External MIDI Devices	70, 77, 20, 82, 83
to External MIDI Sound Generators	70
to External Sequencer (Sync)	56
as An External MIDI Sound Generator	82

Copy	
~ Arpeggio Pattern	59
~ Patch (Assigning Patches before Saving)	30
Cord Hook	12

D

Damper (~ Hold)	47
Default Setting	81
Delay	42, 43
~ Time	43
Panning ~	43
Short ~ (Chorus)	44
Detune	34
Diminish	67, 68
Duration	57
Edit Mode	28

E

Effect (Effector)	42
Selecting ~ Type (Reverb)	42
Selecting ~ Type (Chorus)	43
Selecting ~ Time (Reverb/Delay)	43
Temporarily Turning Off Effects (Bypass)	44
External Guitar Effect	13
End (Arpeggio)	61
Envelope Follow	37
Exclusive (System Exclusive Message)	31, 90, 95
Expression Pedal	49

F

Filter (Digital ~)	33
Finger (~ Picking, Play Feel)	37
Flanger	43
Foot Pedal (onboard)	9

G

General-purpose Controller	92, 94, 98
Glide (Pitch ~)	24, 46
Grid (Arpeggiator)	51
Guitar ~ Out/~ Return	13
~ Select (Switching the Guitar)	82

H

Hall (~ Reverb)	42
harmonist	64
Turning harmonist On/Off	65
Selecting harmony Tones (harmony-sel)	66
Setting harmonic Intervals (h-style)	66
Setting the Key (h-key)	68
Changing the Key during a Performance	
From External MIDI Pedal or Other Device	
with MIDI Note Messages (h-remote)	69
Switching Between Major and Minor	69

Head Phones	12, 13
Hold	24, 47
Damper ~	47
Sostenuto ~	47
Strings ~	48
~ for Arpeggiator	53

I

Implementation (MIDI ~)	92
(MIDI ~ Chart)	98
Indicator (5 Points ~)	9
Initializing (Restoring the Settings to Their Defaults)	81

K

Key (harmonist)	68
Changing the ~ during a Performance (Remote)	69

L

Latch (~ Hold)	54
Level (Volume)	
GR-30 ~	16
Patch Volume	36
Adjust 1st Tone to 2nd Tone Volume Balance	35
Reverb Level Setting	43
Volume Control via Expression Pedal	49
Local Control Off (MIDI)	78

M

Major Key	68, 69
Master Tune	15
Metronome	61
MIDI	
Bulk Dump	31
~ Bank Select	73
Connect to External ~ Device	70, 76, 77, 20, 82, 83
Changing the Key from External ~ Pedal or Other Device with ~ Note Messages (h-remote)	69
Chromatic with External ~	40, 71
Expression Pedal (Transmit via ~)	50, 76
Exclusive (~ System Exclusive Message)	31, 90, 95
Local Control Off	78
~ Implementation Chart	98
~ Implementation	92
~ Mono/Poly Mode	72
Program Change Number	73
Transposing by Semitone for External Devices	34, 76
Using as An External MIDI Sound Generator	82
MIDI Controller Message	92, 94
Expression Pedal (Transmit via MIDI)	50, 76
Guitar Envelope Follow	75
Transmission of MIDI Controller No.7 (Volume)	83
Transmission of MIDI Controller No.0, No.32 (MIDI Bank Select)	73
Tempo Control via MIDI (Tap Tempo)	92
Minor Key	68, 69
Mode (MIDI Mono/Poly ~)	72
Mode (Condition of Base Module)	26, 28
Play ~	13, 26, 28
Edit ~	28
Pedal Effect ~	22, 26, 28

Using Pedal Function during Play Mode	26
Modulation	24, 46
Mono Mode (MIDI)	72
Multi Timber (External ~ sound generator)	77

N

Narrow Wah	45
No Dynamics (Play Feel)	37
Normal (Play Feel)	37

O

Octave (Transpose)	34, 76
--------------------------	--------

P

Pan39	
Setting	39
Control via Expression Pedal	49
Panning Delay	42
Parameter List	99
Patch	17, 29, 108
User ~	17
Preset ~	17
Write	30
Select	18
Change Patch Display (LED) (Group/Bank/Number:Decimal)	20
Pattern (Arpeggio ~)	51
Create ~ (Step)	60
Create ~ (Real-time)	61
Create ~ (via Computer/Sequencer)	62
~ Copy	59
Pedal	22, 45
~ Effect Mode	22, 45
Wah Setting	45
Glide Setting	46
Hold Setting	47
Expression ~ Setting	49
Pitch	
~ Transposing by Semitone (1st/2nd Tone)	34
(MIDI)	76
~ Detune (1st/2nd Tone)	34
~ Glide (onboard Pedal)	24, 46
Control via Expression Pedal	49
Plate (~ Reverb)	42
Play Mode	13, 26
Play Feel	37
Poly Mode (MIDI ~)	72
Reception	82
Transmission	72
Program Change Number	
~ Reception (Patch)	93
~ Transmission	72, 81
Reordering ~s from the Beginning	81
Panning Odd/Even String Separately	39
Producing Sounds	11

R

Random (~ Pan)	39
Real Time Input Method (Arpeggio Patterns)	61

Remote (harmonist Key ~).....	69
Rest (Input Pattern).....	60
Reverb	42
Room (~ Reverb).....	42

S

Save (Patch ~).....	34
Sequencer (External MIDI ~).....	77
Connect to ~.....	77
Syncing Arpeggiator Tempo to the ~.....	56
Service Spot.....	106
Shuffle (Arpeggiator).....	58
Soft (~ Picking:Play Feel).....	37
Sostenuto (~ Hold).....	47
Special Effects (Chorus).....	44
Specifications	89
Staccato (Arpeggiator).....	57
Step Input Method (Arpeggio Patterns ~).....	60
String Select.....	9
Setting for Each Strings.....	35
~ for the Tone Select (Layer).....	34, 35
Transposing by Semitone (1st Tone).....	34, 35
Transposing by Semitone (2nd Tone).....	34, 35
Transposing by Semitone (MIDI).....	34, 76
Program Change Number (MIDI).....	73
System	
MIDI ~ Exclusive Message.....	31, 90, 95
~ Parameters.....	99
Selecting Notes and Rhythm.....	58
Setting Input Sensitivity.....	14
Pickup ~.....	14
~ Switching the Guitar's Sensitivity (Guitar Select).....	82
Setting per Strings.....	9
Setting the Key(harmony).....	68

T

Tap Tempo (~ Teach).....	57
Tapping (Play Feel).....	37
Tempo (Arpeggiator's ~).....	56
~ Control with Expression Pedal.....	49
Tenuto (Arpeggiator).....	57
Tie (Arpeggio Patterns ~).....	60
Tone	29
~ List.....	104
Select Tone (1st/2nd).....	32
Selecting and Playing Sounds (Patches).....	18
Edit ~.....	32 — 36
Increasing/Decreasing Attack Time of ~.....	32
Changing ~ Release.....	33
Changing ~ Brightness.....	33
Setting Layer Type.....	34
Detuning Between the 1st ~ and 2nd ~.....	35
Volume Balance Between 1st ~ and 2nd ~.....	35
Transpose	34, 76
~ 1st Tone.....	34
~ 2nd Tone.....	34
~ External MIDI sound generator.....	76
Trouble Shooting.....	85
Tuner (Guitar ~).....	15, 25

U

Using a Monaural Amplifier.....	12, 13
---------------------------------	--------

V

Velocity	92, 94, 98
Vibrate (Modulation).....	46
Volume (Total Volume).....	16
Patch Level.....	36
1st Tone/2nd Tone Volume Balance.....	35
Reverb (Delay) Level.....	43
Expression Pedal.....	49

W

Wah (Onboard Pedal Effect).....	24, 45
Auto Trigger ~.....	45
Touch ~ (with Envelope Follow).....	38
Wah (Expression Pedal).....	49

INDEX (PANEL PRINT)

0 — 9

1, 2, 3, 4 (Pedal).....	9, 18
1ST TONE	34
2ND TONE	34
ATTACK	32
BRIGHTNESS.....	33
RELEASE	33
TONE#	32

A

ARPEGGIO	51
A-DURATION	57
A-RHYTHM	58
A-TEMPO	56
ARPEGGIO SEL.....	55
ARP/HAR	23

B

BANK (display).....	17, 19
BANK SHIFT	13, 19
BEGIN/END	60, 61

C

CTRL. ARP/HAR.....	23, 57
COMMON	36
PATCH LEVEL.....	36
PLAY FEEL	37
PAN	39
CHROMATIC.....	40

E

EDIT TARGET.....	10
EDIT/PLAY	8, 28
EFFECT	42
REVERB TYPE	42
REVERB LEVEL.....	43
REV/DLY TIME	43
CHORUS TYPE.....	43
EFFECT BYPASS.....	44
ENTER	61

F

FOOT PEDAL.....	9
WAH TYPE.....	24, 45
GLIDE TYPE.....	24, 46
HOLD TYPE	24, 47, 53
EXP PEDAL.....	49

G

GK IN	10
(Installing the GK-2A	11)
GROUP (display).....	17, 19
GTR-ENV FOLLOW.....	38
GUITAR	
OUT	10, 13
RETURN	10, 13
GUITAR SELECT.....	82
GUITAR SYNTHESIZER.....	7

H

harmony	64
h-key	68

h-remote	69
h-style	66
harmony SEL.....	66

HOLD	24, 47
------------	--------

L

LOCAL OFF	78
-----------------	----

M

MIDI	70
BEND RANGE	71
CHANNEL	71
PG CHNG#.....	72
TRANSPOSE	76
MIDI IN/OUT	10
MIX OUT	10, 12

N

NUMBER (display).....	17, 18
-----------------------	--------

P

PARAMETER SLECT.....	9, 26, 28
PATCH	17, 29
PATCH (+/-).....	10
PATCH INC/DEC BY S1/S2.....	18, 26
P-GLIDE	24, 46
PHONES	10, 12
PICK UP SENS(1-6).....	14
POWER	10, 13

R

REST	60
Roland	106 (SERVICE SPOT)

S

SENS	14
STRING SELECT.....	9, 35
6-5.....	35
ALL.....	9, 35
SYSTEM	
BEND RANGE	71
CHANNEL	71

T

TIE	55, 60
TO TOP	55, 60
TONE MIX	34
1:2 BAL	55
LAYER.....	34
TRANS 1ST.....	34
TRANS 2ND.....	34
TUNE (TUNER)	15

V

VALUE (+, -)	9
VOLUME	8, 12

W

WAH	24, 45
WRITE PATCH?	30
WRITE TO	30

Tone List

No.	Name	No.	Name	No.	Name	No.	Name
<PIANO TYPE>		46	ORGAN 6	<BASSES>		141	SICU +TRON
1	A.PIANO1	47	JUNO ORGAN	93	UPRIGHT BASS	142	SICU PIPE
2	SA PIANO	48	FULL ORGAN	94	ACOUSTIC BASS	143	ZAMPONA
3	A.PIANO2	49	PIPE ORGAN 1	95	FRETNOT BASS	144	OCARINA
4	E.GRAND	50	PIPE ORGAN 2	96	FRETLESS 1	145	ZAMPONA +TRI
5	HONKYTONK	<GUITAR TYPE>		97	FRETLESS 2	146	ZANP +BREATH
6	A.PIANO +VIB	51	NYLON GUITAR SW	98	DETUNE FRETLESS	147	BEND PIPE
7	A.PIANO +VOX	52	NYLON GUITAR P	99	SLAP BASS 1	<BRASS>	
8	A.PIANO +STGS	53	NYLON GUITAR MP	100	SLAP BASS 2	148	SOFT TRUMPET
9	POP E.PIANO	54	NYLON +SCAT	101	DETUNE SLAP	149	FLUGEL
10	RHODES	55	GUITAR PAD	102	FINGERED BASS	150	MUTE TRUMPET
11	E.PIANO 1	56	GUITAR HARMONIC	103	DETUNE BASS	151	TROMBONE
12	E.PIANO 2	57	STEEL GUITAR	104	MUTED BASS	152	TUBA
13	E.PIANO 3	58	STEEL GUITAR SW	105	PICK BASS 1	153	FRENCH HORN 1
14	FM E.PIANO	59	12ST GUITAR 1	106	PICK BASS 2	154	FRENCH HORN 2
15	FM E.PIANO MIX	60	12ST GUITAR 2	107	PICK BASS 3	155	AT-HORN
16	D50 E.PIANO 1	61	DETUNE 12ST	108	PICK BASS 4	156	DUAL HORN
17	D50 E.PAINO 2	62	JC STRAT	109	TB-303 BASS	157	DETUNE HORN
18	JP-8 PULSE 1	63	SUPER E.GUITAR	110	RESO BASS 1	158	VELO HORN
19	JP-8 PULSE 2	64	CLEAN TEL	111	RESO BASS 2	<REED>	
20	SYN CLAVI 1	65	JAZZ GUITAR	112	RESO BASS 3	159	CLARINET
21	SYN CLAVI 2	66	PEDALSTEEL	113	SH-5 SAW BASS	160	OBOE
22	JP-8 PULSE 3	67	DST SOLO GUITAR	114	OCT BASS 1	161	OBOE+CLARINET
23	DIGI CLAV	68	O.DRIVE GUITAR	115	SH-101 BASS 1	162	SHAHNAI
24	GIT CLAV	69	ROCK DUO	116	SH-101 BASS 2	163	MIZMAR
25	FROG WAVE	70	GUITAR LEAD FB	117	SH-101 BASS 3	164	HARMONICA
<VIBE TYPE>		71	FEEDBACK 1	118	SH-101 BASS 4	165	HARMO+SCAT
27	VIBRAPHONE 1	72	FEEDBACK 2	119	JP-4 BASS	166	ACCORDION FR
28	VIBRAPHONE 2	73	POWER CHORD	120	OCT BASS 2	167	DT. ACCORDION
29	GLOCKEN	74	TOUCH WAH GTR	121	MINI BASS 1	168	SOPRANO SAX
30	BALAPHONE	75	GTR FEEDBACK	122	MINI BASS 2	169	ALTO SAX
31	MARIMBA	76	ONLY FEEDBACK	123	DETUNE MG	170	ALTO GRWL
<ORGANS>		77	HARP	124	MG+OB BASS	171	BLOW SAX
32	ORGAN 1	78	HARP	125	PDL BASS 1	172	SAX V-SW
33	ORGAN 2	79	SYNTH HARP	126	PDL BASS 2	173	T SAX HARD1
34	JAZZ ORGAN 1	80	BANJO	127	PDL BASS 3	174	TENOR GROWL
35	JAZZ ORGAN 2	81	BANDOLIN	128	SYNC BASS	175	BARI SAX
36	ORGAN 3	82	DETUNE BANDOLIN	129	KICK+BASS	176	T SAX HARD2
37	ROCK ORGAN 1	83	FLAT MANDOLIN	<PIPES>		177	ALTO + BARI
38	POWER B SLOW	84	E.SITAR 1	130	FLUTE	<BRASS SECTION>	
39	POWER B FAST	85	E.SITAR 2	131	TRON FLUTE	178	BRS SECT 1
40	ROCK ORGAN 2	86	SITAR + DRONE	132	PICCOLO	179	BRS SECT 2
41	ORGAN 4	87	TAMBRA	133	CHIF FLUTE	180	BRS SECT 3
42	DIST ORGAN	88	INDIA	134	VOX FLUTE	181	BRS SECT 4
43	60S ORGAN	89	ZITHER	135	SING FLUTE	182	R&R BRASS
44	CHEESE ORGAN	90	DETUNE ZITHER	136	VIBE +FLUTE	183	OCT BRASS
45	ORGAN 5	91	KAYAKEUM	137	FLGL +FLUTE	184	SFZ BRASS
		92	KOTO	138	MUTE +FLUTE		
			SHAMISEN	139	BLOWPIPE		
				140	BLOWPIPE +OB		

No.	Name	No.	Name	No.	Name	No.	Name
185	TRUMPET+SAX	237	OB LEAD	<STRINGS>		338	DIGI BOW
186	TBONE + SAX	238	SYNTH LEAD	285	SOLO VIOLIN 1	339	BOWED GLASS
187	HYBRID BRS	239	TWEETY	286	SOLO VIOLIN 2	340	GR HEAVEN
188	HYBRID SAX	240	WHISTLE	287	FIDDLE	341	UTOPIA
189	ALTO + TPT	241	WHISTLE LEAD	288	ERHU	342	VECTOR VOX
190	TPT + TBONE	242	MG TRIANGLE	289	CELLO	343	OMINOUS
191	FLGL + TPT	243	2600 SINE	290	PIZZICATO STR	344	SWEEP PAD 5
<SYNTH BRASS>		244	BELL LEAD	291	STRINGS SECT	345	ETERNITY
192	BREATH HORN	245	POLY SYNTH 1	292	OCT STRING	346	INVERSION
193	SYN HORN	246	POLY SYNTH 2	293	SLOW STRING	<BELL>	
194	SYN BRASS 1	<SYNTH PAD>		294	BOWED STRING	347	TINK BELL
195	FAT LEAD	247	SAWKEY	295	BRIGHT STRING	348	FANTA BELL
196	ANA BRASS	248	PLUK SWEEP 1	296	HYBD STRING 1	349	SYN BELL
197	JP BRASS	249	CHOW SWEEP	297	HYBD STRING 2	350	SPRK BELL
198	SYN BRASS 2	250	GATED SYNTH	298	HYBD STRING 3	351	ANALOG BELL 1
199	SYN BRASS 3	251	PULSE PAD	299	DRK STRING	352	ANALOG BELL 2
200	OB XP BRASS	252	WIRESRING	300	JP STRING 1	353	DIGITAL BELL
201	OB XP STRGS	253	DIGI PLUK	301	JP STRING 2	354	ASIAN GONG
202	DT SAW PAD	254	METAL PAD	302	OCTJP STRING	355	TEMPLE
203	BRASS BLST	255	PLUK SWEEP 2	303	OCT STR PAD	356	ETHNIC BELL
<SYNTH LEAD>		256	SOFT SYNTH	304	OB OCT	<PERCUSSION>	
204	GR300 LEAD	257	DOO KEY	305	OB + JP	357	KALIMBA 1
205	PLAIN LEAD	258	FANTA SAW	306	VINTAGE SAWS	358	KALIMBA 2
206	SAW LEAD 1	259	BELL PAD	307	OB XP	359	STEEL DRUM
207	SAW LEAD 2	260	HARP PAD	308	SAW STRINGS	360	ANGKLUNG
208	KG800 SAW	261	ATMOSKEY	309	PULSE PAD	361	SEQ SAW 1
209	MG SAW 1	262	WHISPER	310	SOFT PAD	362	SEQ SAW 2
210	D-50 SAW 1	263	FANTAPAD	311	DARK JP PAD	363	SEQ SQUARE
211	SYN SAX	264	BELL VOX 1	312	CHIFF PAD	364	RAVE HIT
212	MG DT SAW	265	FANTASIA	313	HYBD PAD	365	BENDIR
213	MG DT LEAD	266	FANTA VOX 1	<PAD, SWEEP, etc.>		366	TIMPANI
214	OB SAW	267	FANTA VOX 2	314	PROLOGUE	367	DRUM SET
215	JU-2 SAW	<VOICE/CHOIR>		315	SOUND TRACK	368	PERCUS SET
216	CS SAW 1	268	SCAT VOX	316	SYNTH PAD	369	KICK
217	BRIGHT LEAD	269	DOUBLE SCAT	317	SWEEP PAD 1	370	SOLO SNARE
218	D-50 SAW 2	270	CHOIR AAH	318	SWEEP PAD 2	371	CLOSED HIHAT
219	MG SAW 2	271	VOICE AAH	319	SWEEP PAD 3	372	NOIZ PERCUS
220	KG700 SAW	272	ANGEL VOX	320	SWEEP PAD 4	373	SINE PERCUS
221	5TH LEAD	273	SPACE VOX 1	321	SUPER SWEEP	374	VOX PERCUS
222	JP-8 SQUARE	274	BEAUTY VOX	322	ROCK LEAD	375	ORCH HIT
223	MG DT SQUARE	275	CHOIR PAD	323	VOX TREE	<SOUND FX>	
224	PULSE HORN	276	SPACE VOX 2	324	OCARINA PAD	376	WIND
225	VOX LEAD 1	277	VOICE OOHS	325	SQU 5TH PAD	377	ATMOSPHERE
226	RESO LEAD 1	278	DOUBLE VOX	326	SQUARE PAD	378	AMBIENCE
227	RESO LEAD 2	279	SYNTH VOX	327	HOLLOW PAD	379	FX BELL
228	FM LEAD	280	FINE PAD	328	BLASTER	380	FX BOMB
229	JP-8 PULSE 4	281	FINE VOX	329	JUNO RAVE	381	PINK BOMB
230	VS LEAD	282	DIGI VOX	330	TECHNO	382	SFX1
231	DIGI WAVE 3	283	SYNTH HARM	331	DIRTY STACK	383	SFX2
232	SYNC LEAD 1	284	BREATH	332	STACK PAD 1	384	SFX3
233	SYNC LEAD 2			333	STACK PAD 2		
234	SYNC LEAD 3			334	D-50 HEAVEN		
235	RAVER LEAD 1			335	D-50 PAD		
236	RAVER LEAD 2			336	ECHO VOX		
				337	VIBE PAD		

Information

When you need repair service, call your nearest Roland Service Center or authorized Roland distributor in your country as shown below.

ARGENTINA

Instrumentos Musicales S.A.
Florida 638
(1005) Buenos Aires
ARGENTINA
TEL: (01) 394 4029

BRAZIL

Roland Brasil Ltda.
R. Coronel Octaviano da Silveira
205-05522-410
Sao Paulo BRAZIL
TEL: (011) 843-9577

CANADA

Roland Canada Music Ltd.
(Head Office)
5480 Parkwood Way Richmond
B. C., V6V 2M4 CANADA
TEL: (604) 270 6626

Roland Canada Music Ltd.
(Toronto Office)
Unit 2, 109 Woodbine Downs
Bldg, Etobicoke, ON
M9W 6Y1 CANADA
TEL: (0416) 213 9707

MEXICO

Casa Veerkamp, s.a. de c.v.
Av. Toluca No. 323 Col. Olivar de
los Padres 01780 Mexico D.F.
MEXICO
TEL: (525) 668 04 80

La Casa Wagner de
Guadalajara s.a. de c.v.
Av. Corona No. 202 S.J.
Guadalajara, Jalisco Mexico
C.P. 44100 MEXICO
TEL: (031) 613 1434

PANAMA

Productos Superiores, S.A.
Apartado 655 - Panama 1
REP. DE PANAMA
TEL: 26 3322

U. S. A.

Roland Corporation U.S.
7209 Dominion Circle
Los Angeles, CA 90040-3696,
U. S. A.
TEL: (0213) 685 5141

VENEZUELA

Musiland Digital C.A.
Av. Francisco de Miranda,
Centro Parque de Cristal, Nivel
C2 Local 20 Caracas
VENEZUELA
TEL: (02) 285 9218

AUSTRALIA

Roland Corporation
Australia Pty. Ltd.
38 Campbell Avenue
Dee Why West, NSW 2099
AUSTRALIA
TEL: (02) 982 8266

NEW ZEALAND

Roland Corporation (NZ) Ltd.
97 Mt. Eden Road, Mt. Eden,
Auckland 3, NEW ZEALAND
TEL: (09) 3098 715

CHINA

Beijing Xinghai Musical
Instruments Co., Ltd.
2 Huangmichang Chao Yang
District, Beijing, CHINA
TEL: (010) 6774 7491

HONG KONG

Tom Lee Music Co., Ltd.
Service Division
22-32 Fan Shan Street, Tsim
Wan, New Territories,
HONG KONG
TEL: 2415 0911

INDONESIA

PT Galestra Inti
Kompleks Perkantoran
Duta Merlin Blok E No.6-7
Jl. Cahaya Mada No.3-5,
Jakarta 10130,
INDONESIA
TEL: (021) 6335416

KOREA

Cosmos Corporation
Service Station
261 2nd Floor Nak-Won Arcade
Jong-Ro ku, Seoul, KOREA
TEL: (02) 742 8844

MALAYSIA

Belentys Music SDN BHD
No.142, Jalan Bukit Bintang 55100
Kuala Lumpur, MALAYSIA
TEL: (03) 2443333

PHILIPPINES

G.A. Yupangco & Co. Inc.
339 Gilj Puyat Avenue
Makati, Metro Manila 1200,
PHILIPPINES
TEL: (02) 899 9801

SINGAPORE

Swee Lee Company
BLOCK 231, Bain Street #03-23
Bras Basah Complex,
SINGAPORE 0718
TEL: 3367886

CRISTOFORI MUSIC PTE LTD

335, Joo Chiat Road SINGAPORE
1542
TEL: 3450435

TAIWAN

ROLAND TAIWAN
ENTERPRISE CO., LTD.
Room 5, 9th, No. 112 Chung Shan
N. Road Sec. 2, Taipei, TAIWAN,
R.O.C.
TEL: (02) 561 3339

THAILAND

Theera Music Co., Ltd.
330 Verg. Nakorn Kasom, Soi 2,
Bangkok 10100, THAILAND
TEL: (02) 2248821

BAHRAIN

Moon Stores
Bad Al Bahrain Road,
P.O.Box 20077
State of BAHRAIN
TEL: 231 005

IRAN

TARADIS
Mir Emad Ave. No. 15, 10th street
P. O. Box 15875/4171 Teheran,
IRAN
TEL: (021) 875 6524

ISRAEL

Halilit P. Greenspoon &
Sons Ltd.
8 Retzif Ha'aliya Hashnya St
Tel-Aviv-Yafo ISRAEL
TEL: (03) 6823666

JORDAN

AMMAN Trading Agency
Prince Mohammed St. P. O. Box
825 Amman 11118 JORDAN
TEL: (06) 641200

KUWAIT

Easa Husain Al-Yousifi
P.O. Box 126 Satat 13002
KUWAIT
TEL: 5719499

LEBANON

A. Chahine & Fils
P.O. Box 16-5857 Gergi Zeidan St.
Chahine Building, Achrafieh
Beirut, LEBANON
TEL: (01) 335769

OMAN

OHI Electronics & Trading
Co. LLC
P. O. Box 889 Muscat
Sultanate of OMAN
TEL: 706 010

QATAR

Badie Studio & Stores
P.O. Box 62,
DOHA QATAR
TEL: 423554

SAUDI ARABIA

Abdul Latif S. Al-Ghamdi
Trading Establishment
Middle East Commercial Center
Al-Khobar Dharan Highway
W. hammad st.
P. O. Box 3631 Al-Khobar
31952 SAUDI ARABIA
TEL: (03) 898 2332

SYRIA

Technical Light & Sound
Center
Khaled Ebn Al Walid St.
P.O.Box 13520
Damascus - SYRIA
TEL: (011) 2235 384

TURKEY

Barkat Sanayi ve Ticaret
Siraselvier Cad. Guney Ishani No.
86/6 Taksim, Istanbul TURKEY
TEL: (0212) 2499324

U.A.E.

Zak Electronics & Musical
Instruments Co.
Zabeel Road, Al Sheroq Bldg.,
No. 14, Grand Floor DUBAI
U.A.E.
P. O. Box 8050 DUBAI, U.A.E.
TEL: (04) 266715

EGYPT

Al Fanny Trading Office
9, Ebn Hagar At Askalanj Street,
Ard El Golf, Heliopolis, Cairo,
11341 EGYPT
TEL: (02) 4171828
(02) 4185531

KENYA

Musik Land Limited
P.O. Box 12185 Moi Avenue
Nairobi Republic of KENYA
TEL: (2) 338 346

REUNION

FO - YAM Marcel
25 Rue Jules MermanZI
Chaudron - B179 97491
Ste. Clotilde REUNION
TEL: 28 29 16

SOUTH AFRICA

That Other Music Shop
(PTY) Ltd.
11 Melle Street (Car Melle and
Juta Street)
Braamfontein 2001
Republic of SOUTH AFRICA
TEL: (011) 403 4105

Paul Bothner (PTY) Ltd.

17 Werdmuller Centre Claremont
7700
Republic of SOUTH AFRICA
TEL: (021) 64 4030

AUSTRIA

E. Dematte & Co.
Neu-Rum Siemens-Strasse 4
A-6040 Innsbruck P.O. Box 83
AUSTRIA
TEL: (0512) 26 44 260

BELGIUM/HOLLAND/ LUXEMBOURG

Roland Benelux N. V.
Heutsstraat 1 B-2260 Oevel-
Westerlo BELGIUM
TEL: (014) 575811

BELORUSSIA

TUSHE
UL. Rabkorovskaya 17
220001 MINSK
TEL: (0172) 764-911

CYPRUS

Radex Sound Equipment Ltd.
17 Diagorou St., P.O. Box 2046,
Nicosia CYPRUS
TEL: (02) 453 426
(02) 466 423

DENMARK

Roland Scandinavia A/S
Langtbrogade 6 Post Box 1937
DK-1023 Copenhagen K,
DENMARK
TEL: 32 95 3111

FRANCE

MUSIKENGRO
Zac de Follieuses 01706
Les Echets Mirbel FRANCE
TEL: 472 26 2700

FINLAND

Roland Scandinavia As,
Filial Finland
Lautasaarentie 54 B
Fin-00201 Helsinki, FINLAND
P. O. Box No. 109
TEL: (0) 682 4020

GERMANY

Roland Elektronische
Musikinstrumente
Handelsgesellschaft mbH.
Oststrasse 96, 22844 Norderstedt,
GERMANY
TEL: (040) 52 60090

GREECE

V. Dimitriadis & Co. Ltd.
20, Alexandras St. & Boubofinas
54 St. 106 82 Athens, GREECE
TEL: (01) 8232415

HUNGARY

Intermusica Ltd.
Warehouse Area 'DEPO' P/83
H-2046 Torokbalint, HUNGARY
TEL: (23) 338 041

IRELAND

The Dublin Service Centre
Audio Maintenance Limited
11 Brunswick Place, Dublin 2
Republic of IRELAND
TEL: (01) 677322

ITALY

Roland Italy S. p. A.
Viale delle Industrie, 8
20020 Arese Milano, ITALY
TEL: (02) 9358131

NORWAY

Roland Scandinavia Avd.
Kontor Norge
Lilleakerveien 2 Postboks 95
Lilleaker N-0216 Oslo
NORWAY
TEL: 273 0074

POLAND

P. P. H. Brzostowicz Marian
UL. Blokowa 32, 03624 Warszawa
POLAND
TEL: (022) 679 44 19

PORTUGAL

Caius - Tecnologias Audio e
Musica, Lda.
Rue de Catarina 131
4000 Porto, PORTUGAL
TEL: (02) 38 4456

RUSSIA

Slami Music Company
Sadogava-Triumfalnaja st. 16
103006 Moscow, RUSSIA
TEL: (095) 209 2194

SPAIN

Roland Electronics
de España, S. A.
Calle Bolivia 239 08020 Barcelona,
SPAIN
TEL: (93) 308 1000

SWEDEN

Roland Scandinavia A/S
Danvik Center 28 A, 2 tr
S-131 30 Nacka SWEDEN
TEL: (08) 702 0020

SWITZERLAND

Roland (Switzerland) AG
Musitronic AG
Gerberstrasse 5, CH-4410 Liestal,
SWITZERLAND
TEL: (061) 921 1615

UKRAINE

TIC-TAC
Mira Str. 19/ 108
P.O.Box 180
295400 Munkachevo, UKRAINE
TEL: (03131) 414-40

UNITED KINGDOM

Roland (U.K.) Ltd., Swansea
Office
Atlantic Close, Swansea
Enterprise Park SWANSEA
West Glamorgan SA7 9EJ,
UNITED KINGDOM
TEL: (01792) 702701

For the U.K.

IMPORTANT: THE WIRES IN THIS MAINS LEAD ARE COLOURED IN ACCORDANCE WITH THE FOLLOWING CODE.

BLUE: NEUTRAL
BROWN: LIVE

As the colours of the wires in the mains lead of this apparatus may not correspond with the coloured markings identifying the terminals in your plug, proceed as follows:
The wire which is coloured BLUE must be connected to the terminal which is marked with the letter N or coloured BLACK.
The wire which is coloured BROWN must be connected to the terminal which is marked with the letter L or coloured RED.
Under no circumstances must either of the above wires be connected to the earth terminal of a three pin plug.

For EU Countries

Apparatus containing Lithium batteries

ADVARSEL!

Lithiumbatteri - Eksplosjonsfare ved feilagtig håndtering.
Udskiftning må kun ske med batteri af samme fabrikat og type.
Levér det brugte batteri tilbage til leverandøren.

ADVARSEL!

Lithiumbatteri - Eksplosjonsfare.
Ved utskifting benyttes kun batteri som anbefalt av apparatfabrikanten.
Brukt batteri returneres apparatleverandøren.

CAUTION

Danger of explosion if battery is incorrectly replaced.
Replace only with the same or equivalent type recommended by the manufacturer.
Discard used batteries according to the manufacturer's instructions.

VARNING!

Explosionsfara vid felaktigt batteribyte.
Använd samma batterityp eller en ekvivalent typ som rekommenderas av apparattillverkaren.
Kassera använt batteri enligt fabrikantens instruktion.

VAROITUS!

Paristo voi räjähtää, jos se on virheellisesti asennettu.
Vaihda paristo ainoastaan laitevalmistajan suosittelemaan tyyppiin. Hävitä käytetty paristo valmistajan ohjeiden mukaisesti.

For EU Countries



This product complies with the requirements of European Directive 89/336/EEC.

For the USA

FEDERAL COMMUNICATIONS COMMISSION RADIO FREQUENCY INTERFERENCE STATEMENT

This equipment has been tested and found to comply with the limits for a Class B digital device, pursuant to Part 15 of the FCC Rules. These limits are designed to provide reasonable protection against harmful interference in a residential installation. This equipment generates, uses, and can radiate radio frequency energy and, if not installed and used in accordance with the instructions, may cause harmful interference to radio communications. However, there is no guarantee that interference will not occur in a particular installation. If this equipment does cause harmful interference to radio or television reception, which can be determined by turning the equipment off and on, the user is encouraged to try to correct the interference by one or more of the following measures:

- Reorient or relocate the receiving antenna.
- Increase the separation between the equipment and receiver.
- Connect the equipment into an outlet on a circuit different from that to which the receiver is connected.
- Consult the dealer or an experienced radio/TV technician for help.

Unauthorized changes or modification to this system can void the users authority to operate this equipment.
This equipment requires shielded interface cables in order to meet FCC class B Limit.

For Canada

NOTICE

This Class B digital apparatus meets all requirements of the Canadian Interference-Causing Equipment Regulations.

AVIS

Cet appareil numérique de la classe B respecte toutes les exigences du Règlement sur le matériel brouilleur du Canada.

Preset Patch List

Group E (A)		Group F (B)		Group G (C)		Group H (D)	
No.	Name	No.	Name	No.	Name	No.	Name
E11	★ Classic Guitar	F11	Jazz Organ	G11	Square Lead	H11	Mute Bass
E12	● Rock Duo "C"	F12	PipeOrg & Choir	G12	Whistle Lead	H12	Fingered Bass
E13	Sync Lead 1	F13	Flute	G13	Sparkle Pad	H13	8St Bass
E14	★ Drone Sitar	F14	Tron Flute	G14	Wire String	H14	Slap Bass
E21	★ 12St Guitar	F21	Vox Flute	G21	Pulse Key	H21	TB-303 Bass
E22	OB Lead	F22	Pan Flute	G22	Poly Synth	H22	Oct Bass
E23	Fretnot Bass	F23	Zampona	G23	Pluck Sweep	H23	Reso Bass
E24	Prologue	F24	Pipe Lead	G24	Fantavox	H24	SH-101 Bass
E31	★ Tekno Loop	F31	Ocarina	G31	FantaSaw	H31	Pedal Bass
E32	Harmonica	F32	Clarinet	G32	Big Pad	H32	Marimba
E33	GR-300 Lead	F33	Oboe	G33	Blaster	H33	Steel Drum
E34	★ Harp Vox	F34	Mizmar	G34	JUNO Rave	H34	Kalimba
E41	Solo Violin	F41	Harmoscat	G41	JP Strings 1	H41	Angklung
E42	Vox Perc.	F42	● Accordion	G42	Saw Pad	H42	Tinkle Bell
E43	Sicu Pipe	F43	Soprano Sax	G43	Soft JP Pad	H43	Synth Bell
E44	Utopia	F44	Alto Sax	G44	JP Strings 2	H44	Digi Bell
E51	★ Drum Set	F51	Sax V-Switch	G51	Square Pad 1	H51	Asian Gong
E52	Nylon Gt & String	F52	Baritone Sax	G52	Square Pad 2	H52	E.Sitar
E53	Steel Guitar	F53	DistGtr & Sax	G53	Sweep Pad	H53	Tambra
E54	12st Guitar 2	F54	Trumpet	G54	Ominous	H54	Zither
E61	● Pedal Steel	F61	Mute Trumpet	G61	Strings 1	H61	Banjo
E62	Super Guitar	F62	FlugelHorn	G62	Strings 2	H62	F.Mandolin
E63	Clean E.Guitar	F63	Oct Brs Sect.	G63	Oct. Brs&Str	H63	Bandolin
E64	Dist Guitar & Bass	F64	F.Horn Sect.	G64	Fiddle	H64	Harp
E71	WahWah Guitar	F71	Sax Sect.	G71	Erhu	H71	Kayakeum
E72	Ac.Piano	F72	Syn Brass	G72	Cello	H72	Shamisen
E73	Ac.Piano & Vox	F73	JP Brass	G73	Pizz Saw	H73	Thx Bass
E74	Rhodes	F74	Detune Saw Pad	G74	Choir Aahs	H74	Falling Vox
E81	Vibe	F81	VS Lead	G81	Voice Aahs	H81	★ Chiss Pad
E82	Juno Clavi	F82	OB Saw Lead	G82	● SynVox	H82	★ Flamenco Gtr
E83	Rock Organ 1	F83	Sync Lead 2	G83	Bell Choir	H83	★ Tekno Bass
E84	Rock Organ 2	F84	Detune Square	G84	Double Scat	H84	★ JC & Bs

★ : Indicates a Patch for which Arpeggiator is On.

● : Indicates a Patch for which Harmonist is On.

* Group A - D are user patches which can be overwritten.

Their content is identical to the read-only Group E - H above (preset patches).

Roland®

70897778

UPC

70897778



1896:

Roland