

BOSS

BL-1 BULK LIBRARIAN

Owner's Manual

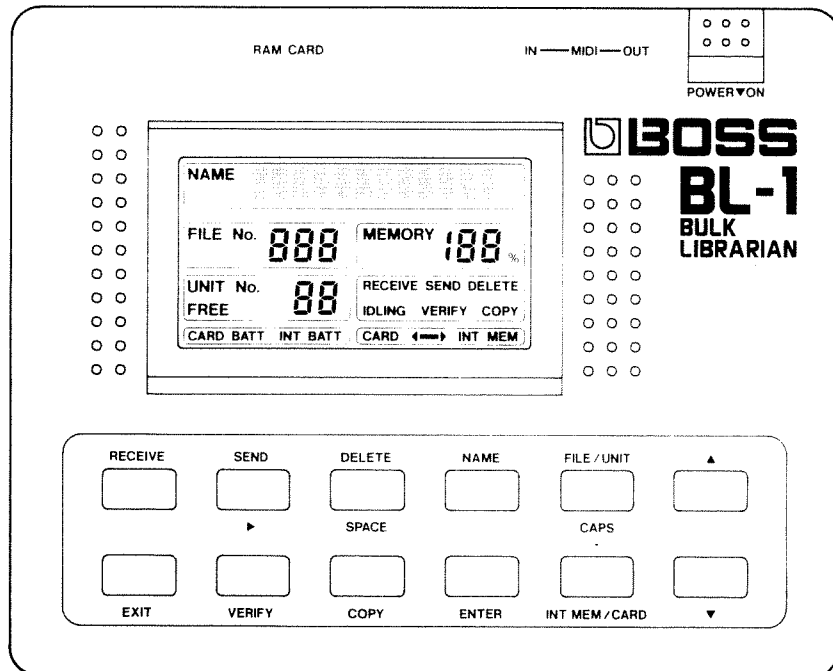

For Germany

Bescheinigung des Herstellers/Importeurs

Hiermit wird bescheinigt, daß der/die/das

BULK LIBRARIAN BL-1

(Gerät, Typ, Bezeichnung)

in Übereinstimmung mit den Bestimmungen der

Amtsbl. Vfg 1046/1984

(Amtsblattverfugung)

funk-entstört ist.

Der Deutschen Bundespost wurde das Inverkehrbringen dieses Gerätes angezeigt und die Berechtigung zur Überprüfung der Serie auf Einhaltung der Bestimmungen eingeräumt.

Roland Corporation Osaka/Japan

Name des Herstellers/Importeurs

For the USA

RADIO AND TELEVISION INTERFERENCE

WARNING — This equipment has been verified to comply with the limits for a Class B computing device, pursuant to Subpart J of Part 15 of FCC rules. Operation with non-certified or non-verified equipment is likely to result in interference to radio and TV reception.

The equipment described in this manual generates and uses radio frequency energy. If it is not installed and used properly, that is, in strict accordance with our instructions, it may cause interference with radio and television reception. This equipment has been tested and found to comply with the limits for a Class B computing device in accordance with the specifications in Subpart J of Part 15, of FCC Rules. These rules are designed to provide reasonable protection against such a interference in a residential installation. However, there is no guarantee that the interference will not occur in a particular installation. If this equipment does cause interference to radio or television reception, which can be determined by turning the equipment on and off, the user is encouraged to try to correct the interference by the following measure:

- Disconnect other devices and their input/output cables one at a time. If the interference stops, it is caused by either the other device or its I/O cable. These devices usually require Roland designated shielded I/O cables. For Roland devices, you can obtain the proper shielded cable from your dealer. For non-Roland devices, contact the manufacturer or dealer for assistance.
- If your equipment does cause interference to radio or television reception, you can try to correct the interference by using one or more of the following measures:
 - Turn the TV or radio antenna until the interference stops.
 - Move the equipment to one side or the other of the TV or radio.
 - Move the equipment farther away from the TV or radio.
 - Plug the equipment into an outlet that is on a different circuit than the TV or radio. (That is, make certain the equipment and the radio or television set are on circuits controlled by different circuit breakers or fuses.)
 - Consider installing a rooftop television antenna with coaxial cable lead-in between the antenna and TV. If necessary, you should consult your dealer or an experienced radio/television technician for additional suggestions. You may find helpful the following booklet prepared by the Federal Communications Commission: "How to Identify and Resolve Radio — TV Interference Problems."

This booklet is available from the U.S. Government Printing Office, Washington, D.C. 20402, Stock No. 004-000-00345-4.

For Canada

CLASS B

NOTICE

This digital apparatus does not exceed the Class B limits for radio noise emissions set out in the Radio Interference Regulations of the Canadian Department of Communications.

CLASSE B

AVIS

Cet appareil numérique ne dépasse pas les limites de la classe B au niveau des émissions de bruits radioélectriques fixes dans le Règlement des signaux parasites par le ministère canadien des Communications.

Copyright © 1991 by BOSS CORPORATION

All rights reserved. No part of this publication may be reproduced in any form without the written permission of BOSS CORPORATION.

Thank you for purchasing the BOSS BL-1 Bulk Librarian. The BL-1 is a MIDI device that allows you to store and organize sound data (bulk data). With the BL-1 you can store data from a variety of MIDI equipment, such as multi-effect units and synthesizers. To make the best use of the BL-1, please read this owner's manual carefully.

[Conventions in this manual]

In this owner's manual, each button on the BL-1 is represented by the letters printed above or below it.

(Example) RECEIVE button is represented by RECEIVE and EXIT button is represented by EXIT.

CONTENTS

IMPORTANT NOTES	4
PANEL DESCRIPTIONS	6
BL-1'S FUNCTIONS	9
OTHER USEFUL FUNCTIONS	
BATTERY REPLACEMENT	10
When to replace the battery	
[1] CONNECTIONS	11
[2] OPERATION	12
1. Making a file (Receive Mode)	13
2. Verifying a file (Verify Mode)	16
3. Sending a file (Send Mode)	18
4. Copying a file (Copy Mode)	20
5. Deleting a file (Delete Mode)	21
6. Changing file names (Name Mode)	22
[3] USING A RAM CARD	23
[4] ERROR MESSAGES	24
MIDI Implementation	25
Roland Exclusive Message	25
SPECIFICATIONS	27

IMPORTANT NOTES

When using an AC adaptor, use only the specified device (PSA-120, 220 or 240). Use of any other power adaptor could result in damage, malfunction, or electric shock.

[Power Supply]

- When making any connections with other devices, always turn off the power to all equipment first; this will help prevent damage or malfunction.
- Do not use this unit on the same power circuit with any device that will generate line noise, such as a motor or variable lighting system.
- The power supply required for this unit is shown on its nameplate. Ensure that the line voltage of your installation meets this requirement.
- Avoid damaging the power cord; do not step on it, place heavy objects on it etc.
- When disconnecting the AC adaptor from the outlet, grasp the plug itself; never pull on the cord.
- If the unit is to remain unused for a long period of time, unplug the power cord.
- The use of an AC adaptor is recommended as the unit's power consumption is relatively high. However, when using batteries, please use the alkaline type.
- When replacing batteries, be sure to follow the instructions in "BATTERY REPLACEMENT" (see page 10).

[Placement]

- Do not subject the unit to temperature extremes (eg. direct sunlight in an enclosed vehicle). Avoid using or storing the unit in dusty or humid areas or areas that are subject to high vibration levels.
- This unit may interfere with radio and television reception. Do not use this unit in the vicinity of such receivers.

[Maintenance]

- For everyday cleaning wipe the unit with a soft, dry cloth (or one that has been slightly dampened with water). To remove stubborn dirt, use a mild neutral detergent. Afterwards, be sure to wipe the unit thoroughly with a soft, dry cloth.
- Never use benzene, thinners, alcohol or solvents of any kind, to avoid the risk of discoloration and/or deformation.

[Additional Precautions]

- Protect the unit from strong impact.
- Do not allow objects or liquids of any kind to penetrate the unit. In the event of such an occurrence, discontinue use immediately. Contact qualified service personnel as soon as possible.
- Never strike or apply strong pressure to the display.
- Before using the unit in a foreign country, consult with qualified service personnel.
- Should a malfunction occur (or if you suspect there is a problem) discontinue use immediately. Contact qualified service personnel as soon as possible.
- To prevent the risk of electric shock, do not open the unit.

[Memory Backup]

- The unit's battery functions during normal operation as well as maintaining the contents of memory when the main power supply is turned off. When the battery becomes weak, there is a risk of losing the contents of the memory. To avoid the unexpected loss of memory data, replace the battery before it becomes weak.
- Please be aware that the contents of memory may at times be lost; when the unit is sent for repairs or when by some chance a malfunction has occurred. Important data should be stored on a RAM card, or written down on paper. During repairs, due care is taken to avoid the loss of data. However, in certain cases, (such as when circuitry related to memory itself is out of order) we regret that it may be impossible to restore the data.

[Changing Batteries]

- Avoid using new batteries together with old ones. Also avoid mixing different types of batteries (eg. regular carbon and alkaline batteries).
- When replacing batteries, be sure to maintain correct polarity.
- While replacing the batteries, memory data can be maintained if power to the unit is supplied by an AC adaptor.
- Remove the batteries whenever the unit is not going to be used for an extended period of time.
- Whenever the unit is not going to be used for an extended period of time, save the contents of memory on a RAM card, and remove the batteries.

PANEL DESCRIPTIONS

< Front Panel >

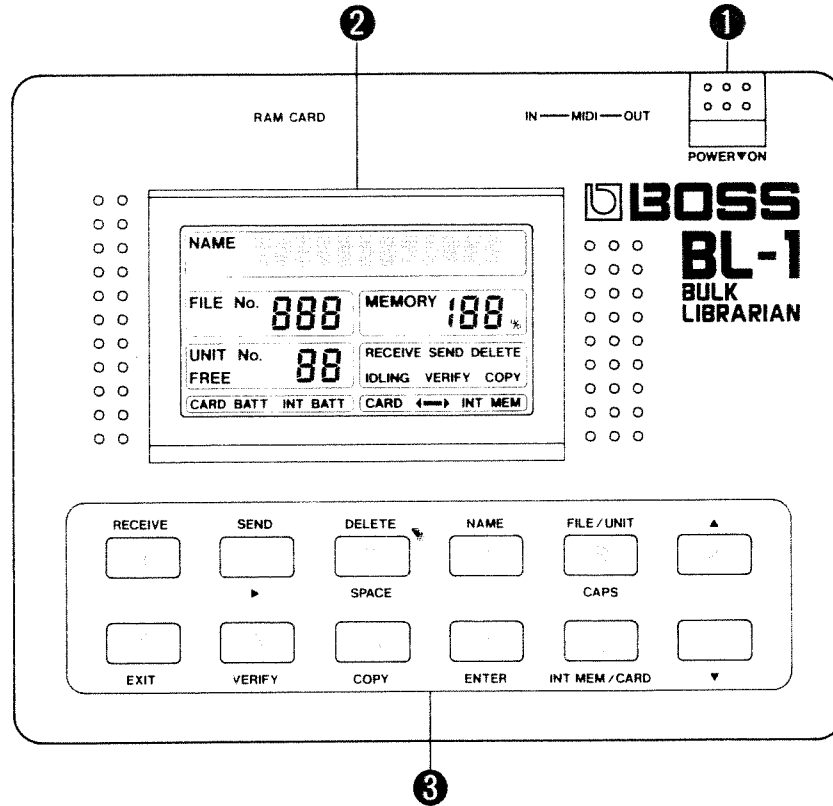

① Power Switch:

Turns the unit on and off.

② Display :

See the next section <Display Indication> .

③ Function Buttons :

- a. **Receive Button** : Use this button to receive bulk data and create a file.
- b. **Send Button** : Use this button to transfer a file (bulk data). This button is also used to move the cursor  during the file naming or name changing procedures.
- c. **Delete Button** : Use this button to delete a file. This button is also used as the SPACE button for deleting characters during the file naming or name changing procedures.
- d. **Name Button** : Use this button to change file names.
- e. **File/Unit Button** : This button selects whether to change file numbers or unit numbers.
- f. **Exit Button** : This button returns the unit to the Stand-by mode from any other mode.
- g. **Verify Button** : Use this button to verify the received data.

< **Rear Panel** >

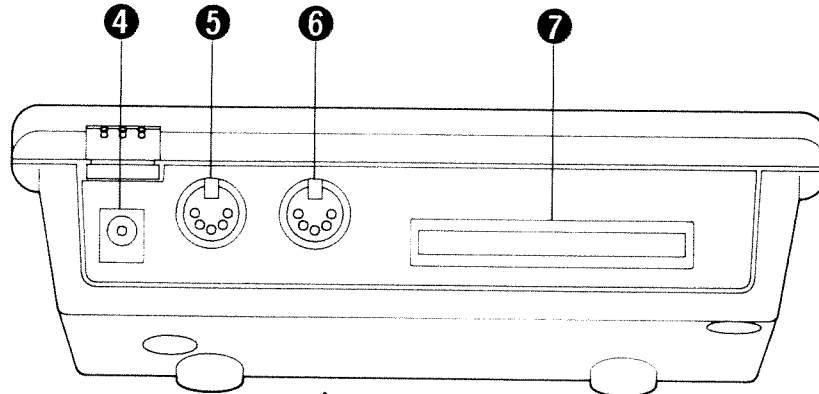

- h. **Copy Button** : Use this button to copy a file between the internal memory and the RAM card. Also, during the file naming or name changing procedures, the same button is used to create upper case characters (CAPS).
 - i. **Enter Button** : Use this button to move to the next procedure in any mode (except for the Stand-by mode).
 - j. **Memory Selection Button** : This selects a memory location : the internal memory or RAM card.
 - k. **▲, ▼ Buttons** : Use these buttons to search for a file, select a character or change unit numbers.
- ④AC Adaptor Jack** :
This Jack accepts connection of an AC adaptor. Be sure to use a PSA-120, 220 or 240, depending on the voltage in your country.
- ⑤MIDI OUT Connector** :
With a MIDI cable, connect this connector to the MIDI IN connector of an external MIDI device.
- ⑥MIDI IN Connector** :
With a MIDI cable, connect this connector to the MIDI OUT connector of an external MIDI device.
- ⑦RAM Card Slot** :
Insert a RAM card (Roland M-256E : optional) into this slot. Be sure to insert the card correctly and securely.

< DISPLAY INDICATION >

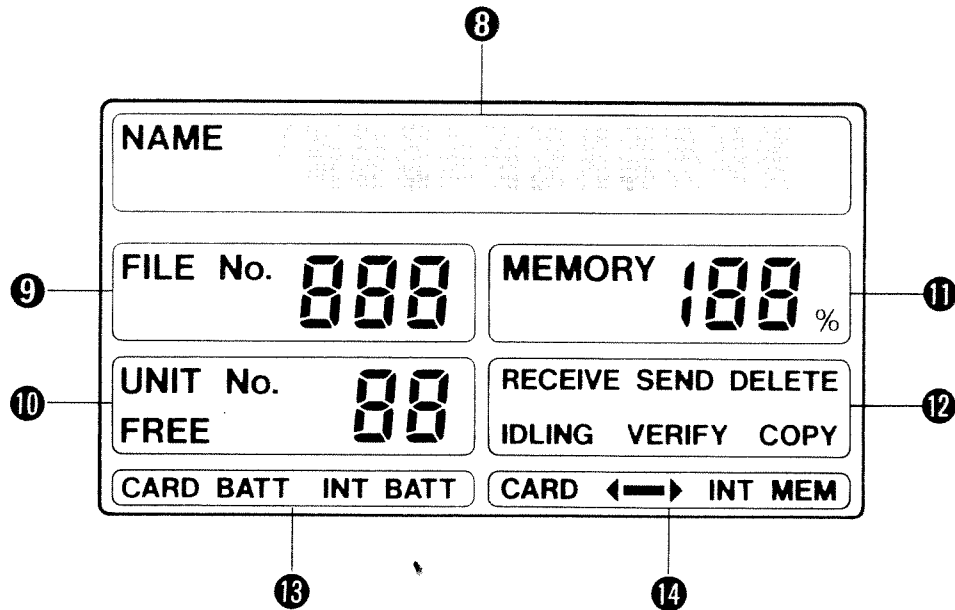

⑧ Name Area :

When [NAME] is lit, this area displays a file name.

When [NAME] is flashing, the BL-1 is writing a file name or changing it.

When [NAME] goes out, an error or caution message is displayed.

⑨ File Number Area :

This displays the file number that indicates the location of the file in memory.

⑩ Unit Number Area :

This displays the unit number to be changed during bulk data reception or transmission. For a detailed explanation, see page 13 "What is a Unit Number ?".

⑪ Remaining Memory Area :

This indicates the amount of available memory (in percent).

⑫ Mode Area :

This indicates the current operating mode.

⑬ Battery Check Area :

[INT BATT] : When flashing, the internal battery is depleted. For a detailed explanation, see page 10.

[CARD BATT] : When flashing, the battery in the RAM card is depleted. Replace the battery according to the instructions of the RAM card.

⑭ Memory Selection Area :

This indicates the memory currently selected: internal memory or RAM card.

When copying a file, the transfer direction is indicated.

BL-1'S FUNCTIONS

The BL-1 stores data created on an external MIDI device either in internal memory or on a RAM card (optional). The BL-1 features the following functions for data storage and transmission:

1. Stores the data (bulk data) transferred from an external MIDI device into internal memory.
2. Stores the data (bulk data) transmitted from an external MIDI device onto a RAM card.
3. Transmits bulk data from the internal memory to an external MIDI device.
4. Transmits bulk data from a RAM card to an external MIDI device.
5. Copy a file between the internal memory and a RAM card.

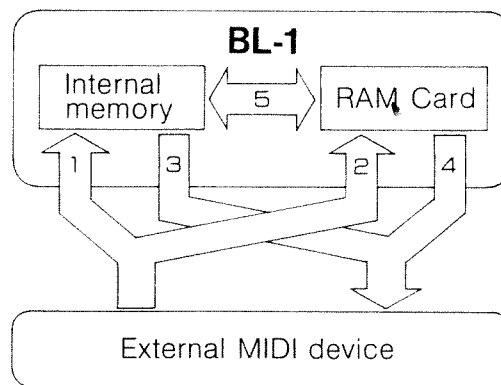

Bulk data is transmitted as Exclusive messages.

The BL-1 can only handle Exclusive messages in the one-way format.

■ OTHER USEFUL FUNCTIONS

File Naming Function : This function allows you to name each data dump received. This helps you organize the files.

Verify Function : This function allows you to compare the file stored on the BL-1 with the external bulk data, and ensure the two are identical. In this way, it verifies that the data is correctly saved in the BL-1.

Unit Number Changing Function : This function allows you to change Unit Numbers of the bulk data of the Roland Exclusive Format Type 4 during reception or transmission.

Battery Check Function : This function automatically checks (and displays) the voltage of the RAM card battery (Page 10).

Auto Power Off Function : This function automatically switches off the BL-1 when no MIDI messages have been received or panel switches operated for five minutes (Page 12).

BATTERY REPLACEMENT

Please be sure that the battery is securely connected to the BL-1, as it maintains memory back up as well as the power supply.

[How to replace the battery]

1. Turn the BL-1 upside down and remove the battery cover by pushing the lock forward and lifting the cover.
2. Pull the snap cord from the battery case and connect the battery to the snap securely as shown in the picture below.
3. Put the battery into the case and replace the battery cover securely (until it clicks into place).

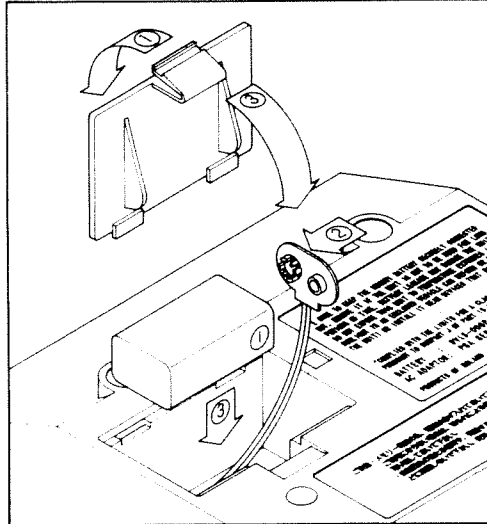

[When to replace the battery]

Please replace the battery when "INT BATT" in the display begins to flash.

When the battery is completely exhausted, the display shows nothing at all. If this happens, replace the battery immediately, or the data in the internal memory will be lost.

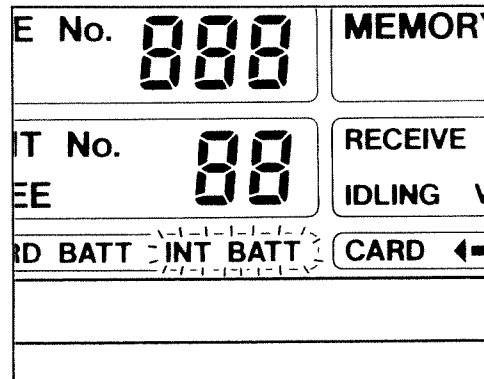

[Notes on battery replacement]

Data in the internal memory is retained for approximately 5 minutes after the battery is removed from the unit. Change the battery quickly, however, to avoid the loss of any data. As an extra precaution, save important data on a RAM card before replacing the battery.

If an AC adaptor is connected to the BL-1, there is no danger of losing data no matter how long you take to replace the battery!

[1] CONNECTIONS

Be sure to use a MIDI device that features bulk-dump capability.

Before using the BL-1, make sure that the supplied battery (S-006P/9V) is properly installed.

To save data into the BL-1 and also to verify it, set up the devices as shown below.

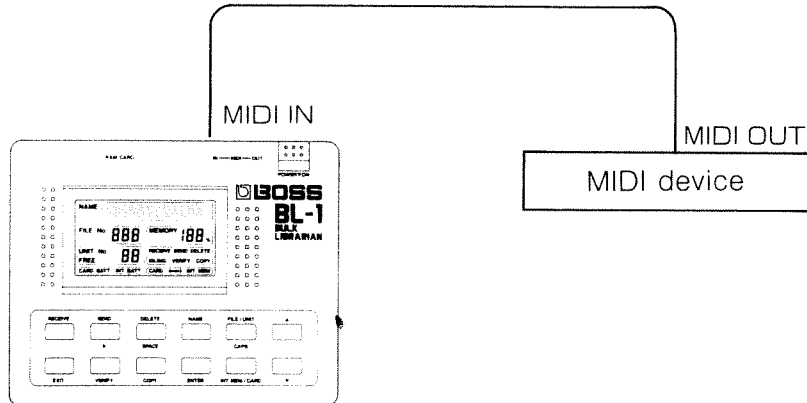

To transmit data from the BL-1 to an external MIDI device, set up the devices as shown below.

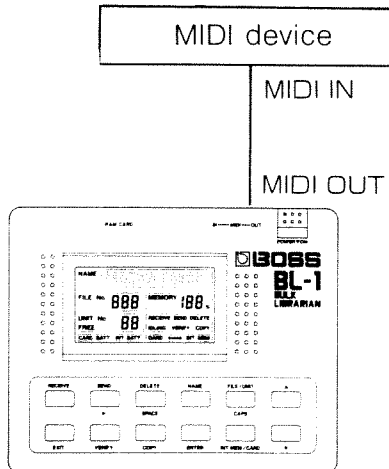

[2] OPERATION

Switching the BL-1 on will automatically select the Stand-by mode. From the Stand-by mode, you can select any of the 6 following modes.

**When the BL-1 is switched off with the Auto Power Off function:
Simply switch on the unit and it will be set to the Stand-by mode.**

- <1> To make a file ⇒ Receive Mode
- <2> To verify a file ⇒ Verify Mode
- <3> To send a file ⇒ Send Mode
- <4> To copy a file ⇒ Copy Mode
- <5> To delete a file ⇒ Delete Mode
- <6> To change file names ⇒ Name Mode

Pressing will return the unit to the Stand-by mode.

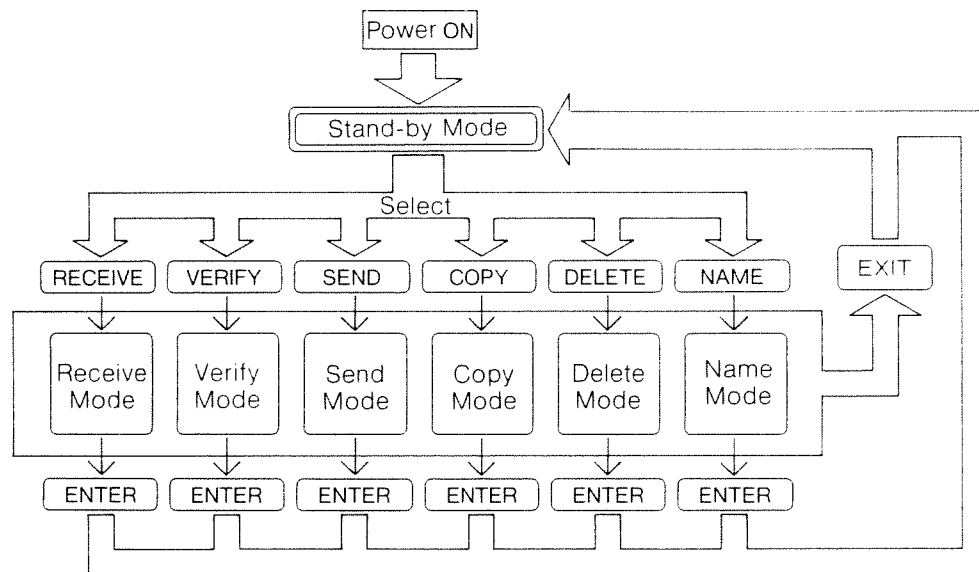

1. Making a file (Receive Mode)

This mode allows you to receive bulk data from a connected MIDI device and create a data file.

[PREPARATION]

- If you are using a brand new RAM card or a RAM card that has been previously used by another unit, you must format the card. (Refer to [3] Using a RAM Card on page 23.)
- To save data onto a RAM card, set the Protect Switch on the card to the "OFF" position. If the Protect Switch is set to the "ON" position, the message "CARD PROTECT" appears in the display and you cannot select the Card Memory on the BL-1.
When you have completed saving data onto a card, be sure to return the Protect Switch to the "ON" position to protect file data from accidental erasure.
- While data is being transmitted onto a RAM card, do not remove the card from the card slot.
- Pressing [EXIT] will return the BL-1 to the Stand-by mode from any other mode, but data received will be erased.

NOTE 1) To receive Roland Exclusive Message TYPE4

Only when the BL-1 receives Roland Exclusive message TYPE4 data can it change the Unit Number before storing it into memory.

If you wish to change the Unit Number, follow steps 1 and 2 above, then select a new Unit Number with [▲] and [▼] and press [ENTER]. 1 to 16 and 17 to 32 (can be selected by pressing [SEND]) are valid as Unit Numbers.

- * If you do not specify a new Unit Number with [▲] and [▼], {FREE} will be set.
- * If the BL-1 is set to other than {FREE}, Unit Numbers of all messages will be automatically changed when more than one message is received simultaneously.
- * Even if you have set the Unit Number, if the BL-1 receives data other than TYPE4, it will automatically returned to {FREE}.

What is a Unit Number ?

Normally, the Unit Number is the message equivalent to the MIDI channel in the Roland System Exclusive message TYPE4. This message is called a Unit Number, Device ID, Device Number, etc. On the Bulk Librarian BL-1, we refer to it as the Unit Number.

[PROCEDURE]

1. From the Stand-by mode:
select the Receive mode.

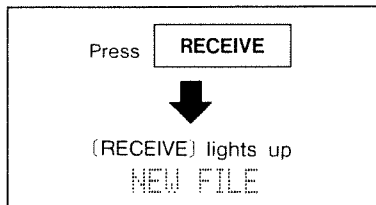

2. Select the memory where
the file is to be stored
(Internal Memory or RAM
Card Memory).

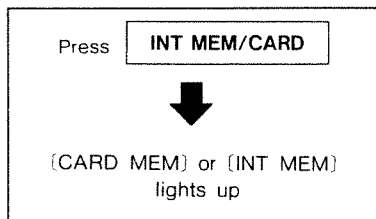

3. Set the BL-1 to the
receive-wait mode.

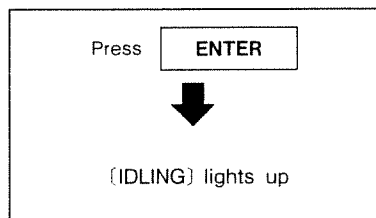

4. Send bulk data from the
external MIDI device.

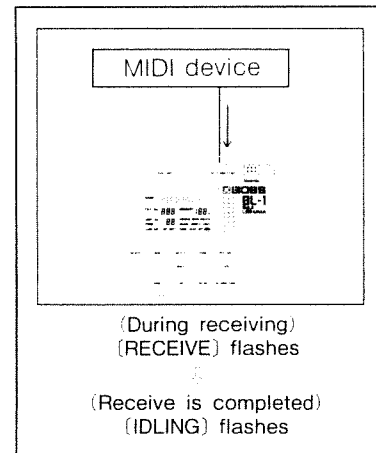

5. Finish receiving data.

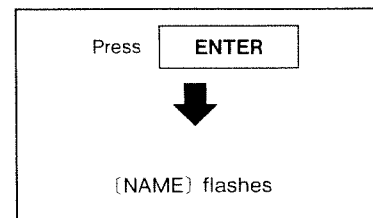

* When the received data exceeds the unit's memory capacity, the BL-1 displays the message "MEMORY FULL!" showing that it cannot create a file. If this happens, return to the Stand-by mode by pressing **EXIT** (this will erase the received data).

6. Create a file name.

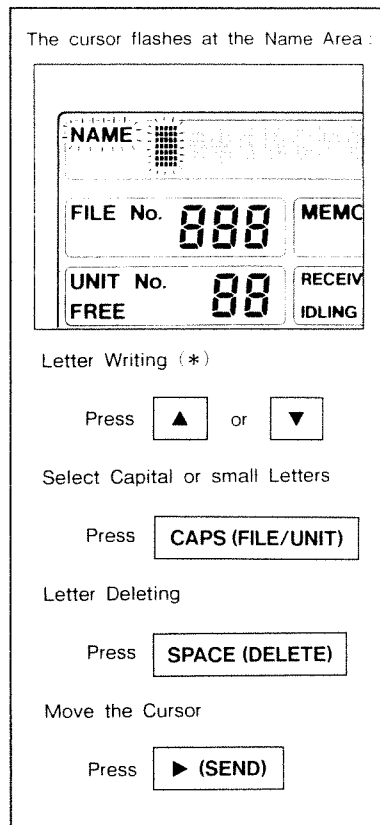

7. Enter the file name and complete the entire procedure.

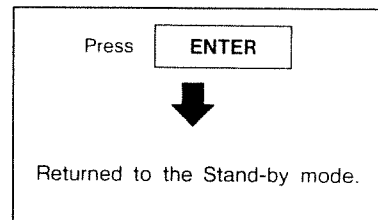

The new file will be the final file (with the largest file number) stored.

* Available letters

A~Z 0~9 ! " # \$ % & ' () * + -
 . / : ; = ? @ [\] ^ _ ` { | } ~
 · space

* The BL-1 cannot create a file without a file name (if the Name Area is left blank).

* If the same file name already exists in the same memory, the message "NAME EXIST!" appears in the display and the file cannot be created. If this happens, create a different file name.

2. Verifying a file (Verify Mode)

When you have made a file, check if the data has been correctly saved. The Verify mode compares the bulk data with the file data saved in the internal memory (or on the card) by receiving the bulk data again.

[PREPARATION]

- In the Verify mode, the data saved in memory is compared with the original bulk data simply by calling it again from the external device. Therefore, you should send the relevant bulk data from the external MIDI device using exactly the same settings under which the file was originally saved.
- Press **EXIT** to return to the Stand-by mode.

[PROCEDURE]

1. Select the Verify mode.

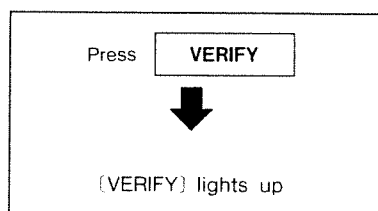

3. Enter the file.

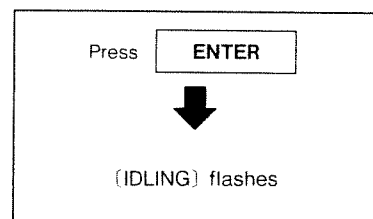

2. Select the file to be verified.

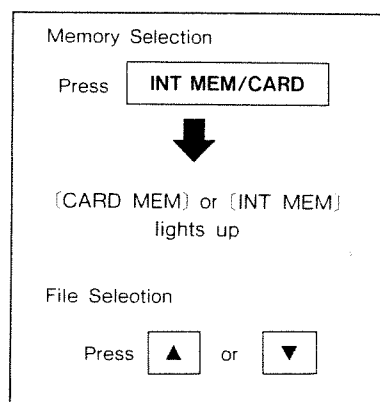

4. Send the bulk data from the external MIDI device again (as before) in the Receive Mode .

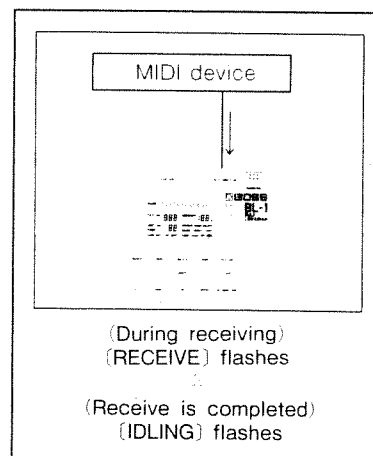

5. Complete data reception.

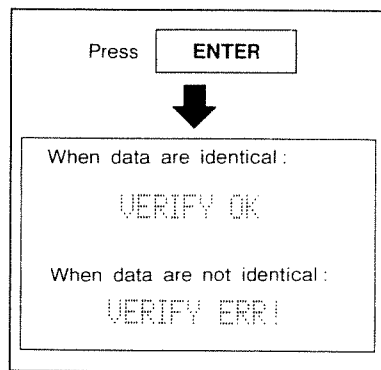

6. Complete the procedure.

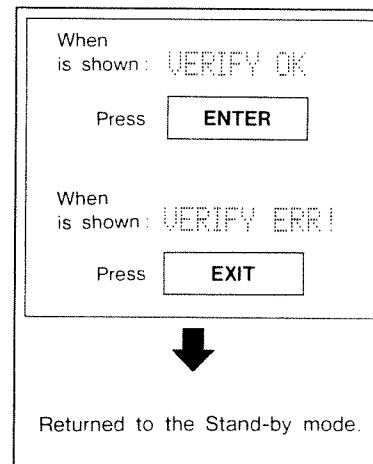

* If any difference is detected between the stored data file and the re-transmitted data, the message "VERIFY ERR!" will be displayed immediately.

To verify Roland Exclusive message TYPE4

Even if the Unit Number of TYPE4 data has been changed by the saving procedure, data can still be verified by the same procedure. (This is because the verification procedure does not compare the Unit Numbers.)

3. Transmitting a file (Send Mode)

This mode allows you to call a file stored in the BL-1 and send it as bulk data.

[PREPARATION]

- When using a RAM card, do not remove it while data is being received.
- Pressing [EXIT] returns the BL-1 to the Stand-by mode.

[PROCEDURE]

1. From the Stand-by mode: select the Send mode.

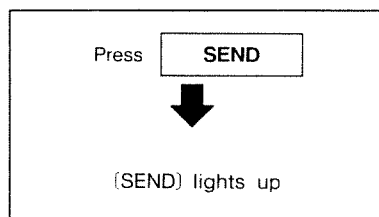

2. Specify the file you wish to transmit.

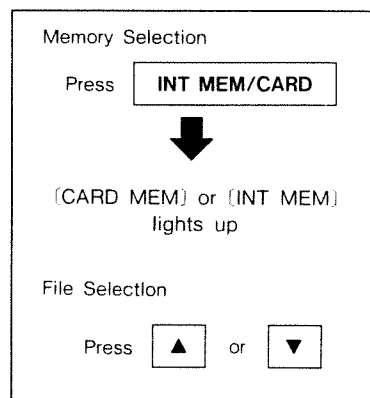

* Refer to Note 2.

NOTE 2) To transmit Roland Exclusive Message TYPE4

Only when the BL-1 transmits Roland Exclusive message TYPE4 data can it change the Unit Number before the external MIDI device receives it. The BL-1 can be set to the same MIDI channel number as the external MIDI device.

If you wish to change the Unit Number, follow steps 1 and 2 above, then press [FILE/UNIT]. Select a new Unit Number with [▲] and [▼] and press [ENTER].

1 to 16 and 17 to 32 (can be selected by pressing [SEND]) are valid as Unit Numbers.

3. Enter the file you have specified and transmit it.

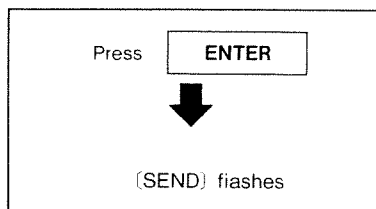

4. Complete the procedure.

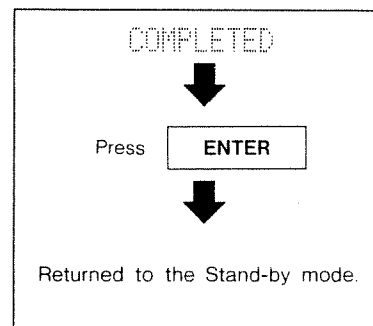

- *If you do not specify a new Unit Number, the Unit Number of the message within the file will be displayed.
- *If you select {FREE}, the data stored in the BL-1 will be transmitted without being changed, and therefore the Unit Number will remain unchanged.
- *If the data in the file is not Roland Exclusive message TYPE4, the Unit Number cannot be changed. The Unit Number will automatically be set to {FREE}.

4. Copying a file (Copy Mode)

This mode allows you to copy a file in the internal memory of the BL-1 onto a RAM card, or a file on a RAM card into the internal memory.

[PREPARATION]

- To copy data onto a RAM card, set the Protect Switch to the "OFF" position.
- During copying, do not remove the RAM card from the BL-1.
- Pressing **EXIT** will return the BL-1 to the Stand-by mode.

[PROCEDURE]

1. Insert the RAM card securely into the card slot .
From the Stand-by mode: select the Copy mode.

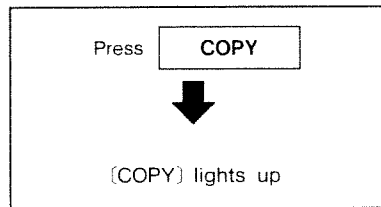

2. Specify the file to be copied.

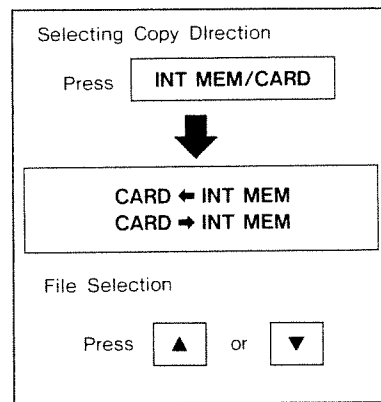

When the file is too large to be saved into memory, the message "MEMORY FULL!" appears while you are holding **ENTER** down, and copying cannot be completed.

3. Enter the file you have specified.

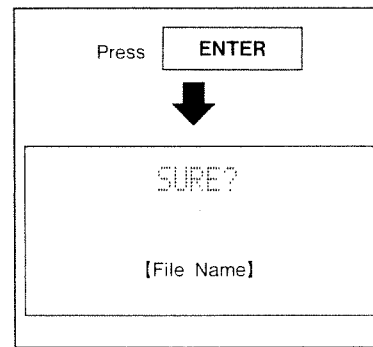

4. Copy the file.

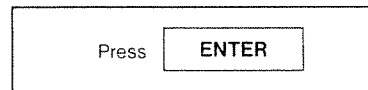

5. Complete the procedure.

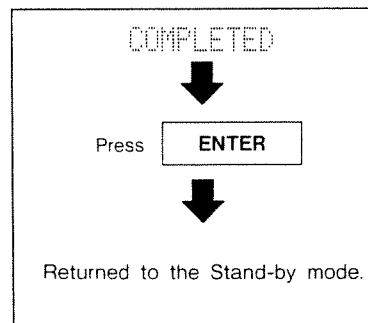

5. Deleting a file (Delete Mode)

This mode allows you to delete a file from internal memory or a RAM card.

[PREPARATION]

- To delete data from a RAM card, set the Protect Switch on the card to the "OFF" position. If the Protect Switch is set to the "ON" position, the message "CARD PROTECT" appears in the display and you cannot select Card Memory. When you have completed deleting data, be sure to return the Protect Switch on the RAM card to the "ON" position to protect the card from accidental erasure.
- While data on a RAM card is being deleted, do not remove the card from the card slot.
- Pressing [EXIT] will return the BL-1 to the Stand-by mode.

[PROCEDURE]

1. From the Stand-by mode: select the Delete mode.

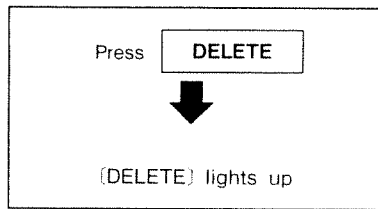

2. Specify the file you wish to delete.

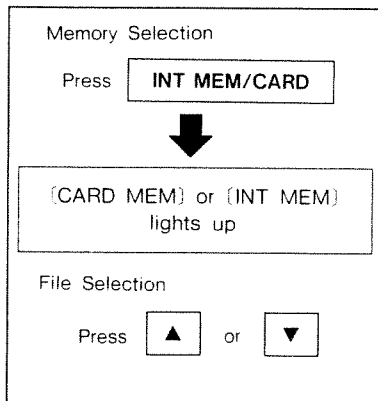

3. Enter the file you specified.

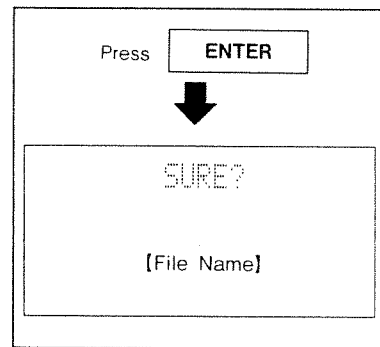

4. Delete the file.

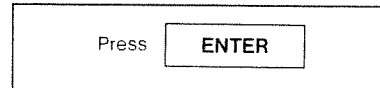

5. Complete the procedure.

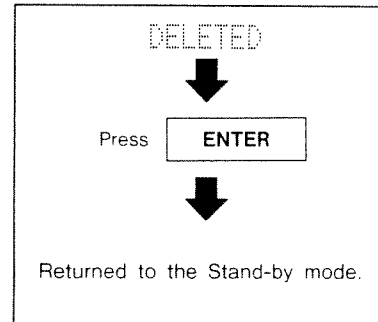

6. Changing File Names (File Name Mode)

This mode allows you to change the name of a file in the internal memory or on a RAM card.

[PREPARATION]

- To change File Names on a RAM card, set the Protect Switch on the card to the "OFF" position. When you have changed File Names, be sure to return the Protect Switch to the "ON" position.
- While file names are being changed on a RAM card, do not remove the card from the card slot.
- Pressing **[EXIT]** will return the BL-1 to the Stand-by mode.

[PROCEDURE]

1. From the Stand-by mode: select the Name mode.

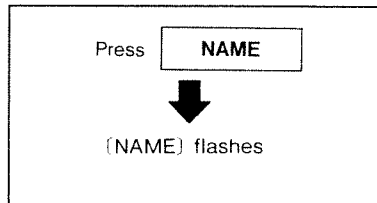

2. Specify the file you wish to rename.

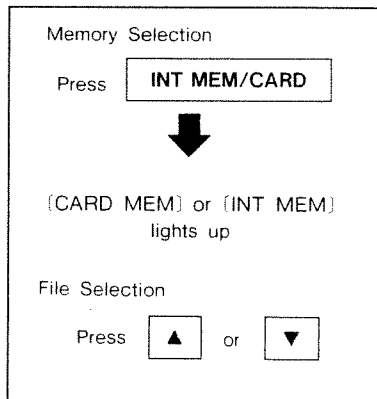

3. Enter the file.

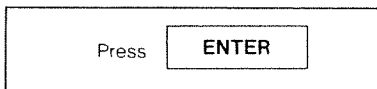

* Available letters

A~Z 0~9 ! " = \$ % & ' () * + -
 . / : ; = ? @ { ¥ } ^ _ ` | .
 space

4. Write a new File Name.

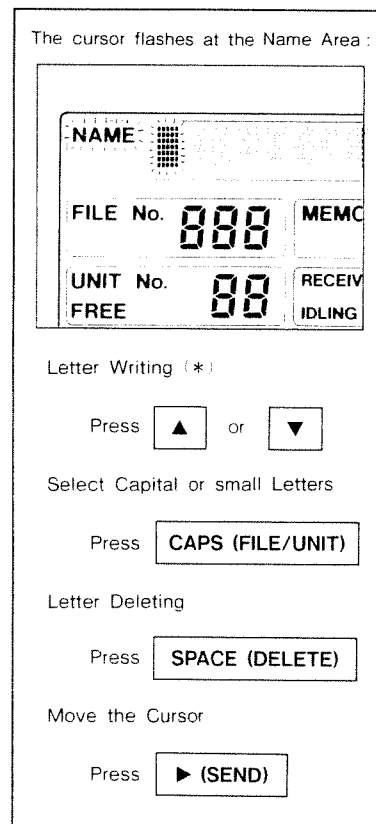

5. Enter the new File Name and complete the procedure.

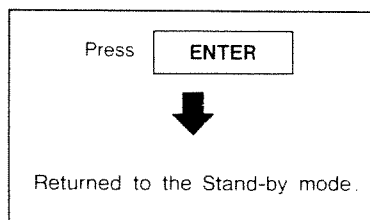

[3] USING A RAM CARD

By using an optional RAM card (Roland M-256E), you can store sound data or setting data onto a RAM card, RAM cards allows you to fully benefit the BL-1's functions such as organizing your files or creating your own bulk libraries, etc.

Formatting your RAM card

When you use a RAM card for the first time on the BL-1, you must format it. The BL-1 has its own formatting system.

- * RAM cards previously used with other units cannot be used with the BL-1 unless they are formatted by the BL-1. However, formatting a RAM card will erase any existing data on the card.
- * Sound ROM cards or other cards generally found on the market cannot be used with the BL-1.

[OPERATION]

1. Set the BL-1 to the Stand-by mode and move the Protect Switch on the RAM card to the "OFF" position. Insert the card into the RAM card slot.
 - * If the Protect Switch on the RAM card is set to the "ON" position, the BL-1 cannot format the card.
2. Press **[INT MEM/CARD]**
If you are using a brand new card or a card formatted by another unit, the BL-1 shows the following message:

"ILLEGAL CARD"
 ↑ ↓ (flashes alternately)
"FORMATTING?"

3. Press **[ENTER]**.
The BL-1 will ask you "SURE?".
 - * If you wish to cancel formatting, press **[EXIT]** to return to the Stand-by mode.
4. Press **[ENTER]** again.
The BL-1 starts formatting the RAM card.
5. When formatting is finished, the message "COMPLETED" is displayed. Press **[EXIT]** to return to the Stand-by mode.

[NOTE]

When you insert or remove a RAM card from the BL-1, be sure that the unit is switched off or is set to the Stand-by mode. Please do not remove the card or bump the unit during file copying, name changing or formatting.

[4] ERROR/CAUTION MESSAGES

If you do not operate the BL-1 correctly or a problem occurs, an error or caution message is displayed. The following table explains each message and how to correct the situation.

Message	Meaning	What to do.
CARD NG!	There is something wrong with the card. (It cannot be formatted.)	Make sure that you are using a designated RAM card (Roland M-256E : optional). Then insert it securely into the card slot with the Protect Switch set to the "OFF" position.
CARD NOTHING	There is no RAM card in the card slot.	Insert a RAM card into the card slot.
CARD PROTECT	The Protect Switch on the RAM card is set to the "ON" position.	Make sure that you are using a designated RAM card (Roland M-256E : optional). Move the Protect Switch set to the "OFF" position.
DATA NOTHING	No data has been received yet.	Make sure that the MIDI cable is connected properly, then transmit data from the external MIDI device.
FILE NOTHING	No file exists in the memory.	Note: If you have not made a file, you cannot move to the Send, Verify, Delete or File Name modes.
ILLEGAL CARD	The card in the RAM Card Slot is not appropriate for the BL-1. (Data cannot be saved onto the card.)	Make sure that you are using a designated RAM card (Roland M-256E : optional). If you wish to format the card, set the Protect Switch to the "OFF" position.
ILLEGAL CARD FORMATTING ?	The card in the slot is brand new or has been formatted by a different device. Do you wish to format it with the BL-1 ?	Format the card if you so desire. To use a brand new card, you must format it (See page 23).
MEMORY FULL!	Make sufficient space by deleting unnecessary files. Repeat the receiving (copy) procedure.	Make a sufficient space by deleting unnecessary file, then repeat an appropriate receiving (copy) procedure.
NAME EXIST!	The same file name already exists in the memory where you want to create a new file.	Create a new File Name, then press ENTER .
VERIFY ERR!	The file data is not exactly the same as the re-transmitted data.	Check if the settings on the transmitting device are the same as when the data was originally received. If the settings are exactly the same, the file stored in memory is different from the original data. Repeat the entire saving procedure.

1. RECOGNIZED RECEIVE DATA

1.1 MEMORIZED DATA

● **System Exclusive**

Status

F0H : System Exclusive
 :
 F7H : EOX (End Of System Exclusive)

2. TRANSMITTED DATA

2.1 All memorized messages are transmitted

* Only the one-way mode

Roland Exclusive Messages

1. Data Format for Exclusive Messages

Roland's MIDI implementation uses the following data format for all exclusive messages (type IV):

Byte	Description
F0H	Exclusive status
41H	Manufacturer ID (Roland)
DEV	Device ID
MDL	Model ID
CMD	Command ID
[BODY]	Main data
F7H	End of exclusive

= MIDI status : F0H, F7H

An exclusive message must be flanked by a pair of status codes, starting with a Manufacturer-ID immediately after F0H (MIDI version 1.0).

= Manufacturer-ID : 41H

The Manufacturer-ID identifies the manufacturer of a MIDI instrument that triggers an exclusive message. Value 41H represents Roland's Manufacturer-ID.

= Device-ID : DEV

The Device-ID contains a unique value that identifies the individual device in the multiple implementation of MIDI instruments. It is usually set to 00H - 0FH, a value smaller by one than that of a basic channel, but value 00H - 1FH may be used for a device with multiple basic channels.

= Model-ID : MDL

The Model-ID contains a value that uniquely identifies one model from another. Different models, however, may share an identical Model-ID if they handle similar data.

The Model-ID format may contain 00H in one or more places to provide an extended data field. The following are examples of valid Model-IDs, each representing a unique model:

- 01H
- 02H
- 03H
- 00H, 01H
- 00H, 02H
- 00H, 00H, 01H

= Command-ID : CMD

The Command-ID indicates the function of an exclusive message. The Command-ID format may contain 00H in one or more places to provide an extended data field. The following are examples of valid Command-IDs, each representing a unique function:

- 01H
- 02H
- 03H
- 00H, 01H
- 00H, 02H
- 00H, 00H, 01H

= Main data : BODY

This field contains a message to be exchanged across an interface. The exact data size and contents will vary with the Model-ID and Command-ID.

2. Address-mapped Data Transfer

Address mapping is a technique for transferring messages conforming to the data format given in Section 1. It assigns a series of memory-resident records-waveform and tone data, switch status, and parameters, for example-to specific locations in a machine-dependent address space, thereby allowing access to data residing at the address a message specifies.

Address-mapped data transfer is therefore independent of models and data categories. This technique allows use of two different transfer procedures: one-way transfer and handshake transfer.

= One-way transfer procedure

This procedure is suited for the transfer of a small amount of data. It sends out an exclusive message completely independent of a receiving device status.

Connection Diagram

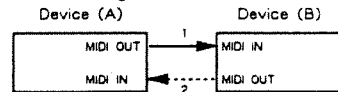

Connection at point 2 is essential for "Request data" procedures. (See Section 3.)

**= Handshake-transfer procedure
 (This device does not cover this procedure)**

This procedure initiates a predetermined transfer sequence (handshaking) across the interface before data transfer takes place. Handshaking ensures that reliability and transfer speed are high enough to handle a large amount of data.

Connection Diagram

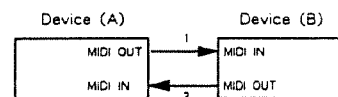

Connection at points 1 and 2 is essential.

Notes on the above two procedures

- * There are separate Command-IDs for different transfer procedures.
- * Devices A and B cannot exchange data unless they use the same transfer procedure, share identical Device-ID and Model ID, and are ready for communication.

MIDI Implementation Chart

Function ...		Transmitted	Recognized	Remarks
Basic Channel	Default	×	×	
	Changed	×	×	
Mode	Default	×	×	
	Messages	×	×	
	Altered	*****		
Note Number	True Voice	×	×	

Velocity	Note ON	×	×	
	Note OFF	×	×	
After Touch	Key's	×	×	
	Ch's	×	×	
Pitch Bender		×	×	
Control Change		×	×	
Prog Change	True #	×	×	

System Exclusive		○	○	* 1
System Common	Song Pos	×	×	
	Song Sel	×	×	
	Tune	×	×	
System Real Time	Clock	×	×	
	Commands	×	×	
Aux Messages	Local ON/OFF	×	×	
	All Notes OFF	×	×	
	Active Sense	×	×	
	Reset	×	×	
Notes	* 1 Only the One-way mode.			

SPECIFICATIONS

● **Internal Memory Capacity :**

approx. 31k byte

● **Switches/Buttons :**

Receive, Send, Delete, Name, File/Unit, Up (▲) and Down (▼), Exit, Verify, Copy, Enter, Memory Selection, Power

● **Display :**

LCD

● **Input/Output Sockets :**

MIDI IN/OUT, RAM Card Slot, AC Adaptor

● **Power Supply :**

9V DC:006P(6F22) Battery x 1;
AC Adaptor (PSA-120, 220 or 240 : optional)

● **Power Consumption :**

40mA

● **Dimensions:**

174(W) × 141(D) × 62(H) mm / 6-7/16" × 5-9/16" × 2-7/16"

● **Weight :**

510g / 1.2lbs (including battery)

● **Accessories :**

MIDI Cable (1m) × 1, Owner's Manual, Battery

● **Options :**

AC Adaptor (PSA-120, 220 or 240)
Memory Card (Roland M-256E)

* Specifications and/or appearance of this product are subject to change without prior notice.

Information

● When you need repair service, call your local Roland Service Station or the authorized Roland distributor in your country as shown below.

U. S. A.

Roland Corp US
7200 Dominion Circle
Los Angeles, CA. 90040 - 3647
U. S. A.
☎ (213)685 - 5141

CANADA

Roland Canada Music Ltd
(Head Office)
5480 Parkwood
Richmond B. C., V6V 2M4
CANADA
☎ (604)270 - 6626

Roland Canada Music Ltd.
9425 Transcanadienne
Service Rd. N.,
St Laurent, Quebec H4S 1V3
CANADA
☎ (514)335 - 2009

Roland Canada Music Ltd.
346 Watline Avenue,
Mississauga, Ontario L4Z 1X2
CANADA
☎ (416)890 - 6488

AUSTRALIA

Roland Corporation
(Australia) Pty. Ltd.
(Head Office)
38 Campbell Avenue
Dee Why West. NSW 2099
AUSTRALIA
☎ (02)982 - 8266

Roland Corporation
(Australia) Pty. Ltd.
(Melbourne Office)
50 Garden Street
South Yarra, Victoria 3141
AUSTRALIA
☎ (03)241 - 1254

NEW ZEALAND

Roland Corporation (NZ) Ltd.
97 Mt. Eden Road, Mt. Eden,
Auckland 3
NEW ZEALAND
☎ (09)398 - 715

UNITED KINGDOM

Roland(UK)Ltd.
Rye Close
Ancells Business Park
Fleet
Hampshire GU13 8UY
UNITED KINGDOM
☎ 0252 - 816181

GERMANY

Roland Elektronische
Musikinstrumente
Handelsgesellschaft mbH.
Oststrasse 96,
2000 Norderstedt
GERMANY
☎ 040/52 60 090

BELGIUM/HOLLAND/ LUXEMBOURG

Roland Benelux N. V.
Houtstraat 1
B - 2431 Oevel - Westerlo
BELGIUM
☎ (0032)14 - 575811

DENMARK

Roland Scandinavia as
Langebrogade 6
Box 1937
DK - 1023 Copenhagen K.
DENMARK
☎ 31 - 95 31 11

SWEDEN

Roland Scandinavia as
DanvikCenter 28 A, 2 tr.
S - 131 30 Nacka,
SWEDEN
☎ 08 - 702 00 20

NORWAY

Roland Scandinavia
Avd. Norge
Lilleakerveien 2
Postboks 95 Lilleaker
N - 0216 Oslo 2
NORWAY
☎ 02 - 73 00 74

FINLAND

Fazer Musik Inc.
Länsituulentie
POB 169
SF - 02101 Espoo
FINLAND
☎ 0 - 43 50 11

ITALY

Roland Italy S. p. A.
Viale delle Industrie 8
20020 ARESE MILANO
ITALY
☎ 02 - 93581311

SPAIN

Roland Electronics
de España, S. A.
Bolivia 239
08020 Barcelona
SPAIN
☎ 93 - 308 - 1000

SWITZERLAND

Musitronic AG
Gerberstrasse 5, CH - 4410
Liestal
SWITZERLAND
☎ 061/921 16 15

Roland CK (Switzerland) AG
Hauptstrasse 21/Postfach
CH - 4456 Tenniken
SWITZERLAND
☎ 061/98 60 55
Repair Service by Musitronic AG

FRANCE

Musikengro
102 Avenue Jean - Jaures
69007 Lyon Cedex 07
FRANCE
☎ (7)858 - 54 60

Musikengro
(Paris Office)
Centre Region Parisienne
41 rue Charles - Fourier,
94400 Vitry s/Seine
FRANCE
☎ (1)4680 86 62

AUSTRIA

E. Dematte & Co.
Neu - Rum Siemens - Strasse 4
A - 6021 Innsbruck Box 591
AUSTRIA
☎ (0512)63 451

GREECE

V. Dimitriadis & Co. Ltd.
2 Phidiou Str., GR 106 78
Athens
GREECE
☎ 1 - 3620130

PORTUGAL

Casa Caius Instrumentos
Musicais Lda.
Rua de Santa Catarina 131
Porto
PORTUGAL
☎ 02 - 38 44 56

HUNGARY

Intermusica Ltd
Warehouse Area 'DEPO'
Budapest. P.O. Box 3,
2045 Torokbalint
HUNGARY
☎ (1)1868905

ISRAEL

D.J.A. International Ltd.
25 Pinsker St.,
Tel Aviv
ISRAEL
☎ 03 - 283015

BRAZIL

FORESIGHT Corporation
R. Alvarenga 591
CEP - 05509 Sao Paulo
BRAZIL
FAX: (011)210 - 0286

HONG KONG

Tom Lee Music Co., Ltd.
Service Division
22 - 32 Pun Shan Street,
Tsuen Wan,
New Territories,
HONG KONG
☎ 415 - 0911

SINGAPORE

Swee Lee Company
Bras Basah Complex #03 - 23
Singapore 0178
SINGAPORE
☎ 3367886

THAILAND

Theera Music Co., Ltd.
330 Verng Nakorn Kasem, Soi 2
Bangkok 10100,
THAILAND
☎ 2248821

MALAYSIA

Syarikat Bentley
No.142, Jalan Bukit Bintang
55100 Kuala Lumpur
MALAYSIA
☎ 2421288

INDONESIA

PT Galestra Inti
Kompleks Perkantoran
Duta Merlin Blok C/59
Jl. Gajah mada No.3 - 5
Jakarta 10130
INDONESIA
☎ (021) 354604, 354606

TURKEY

Barkat Sanayi ve Ticaret
Siraselviler Cad. 86/6 Taksim
Istanbul
TURKEY
☎ 149 93 24

CYPRUS

Radex Sound Equipment Ltd.
17 Panteli Katelari Str
P.O.Box 2046, Nicosia
CYPRUS
☎ 453426, 466423

As of FEB 14, 1991

 Roland®

2604062200

UPC

2604062200



18981

 **BOSS**