

REVERB MODULE

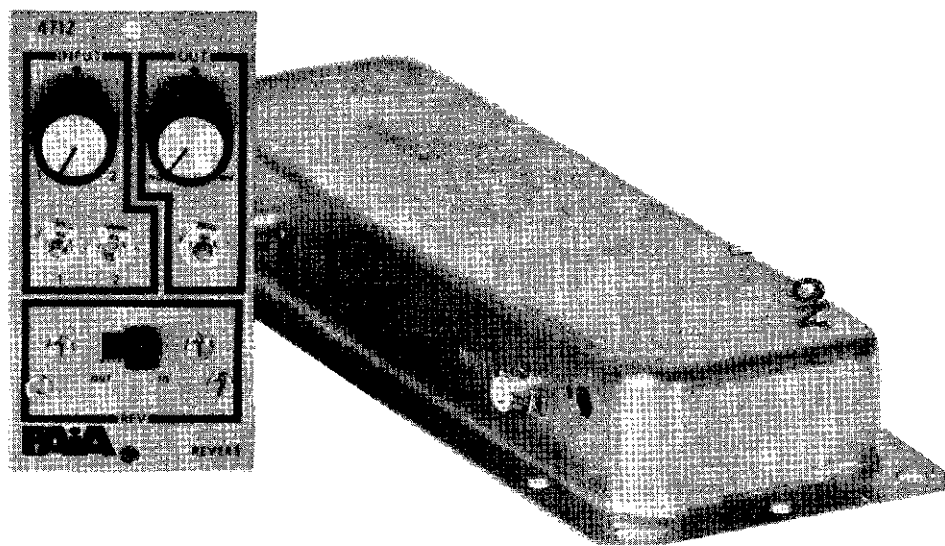

A reverberation unit is a natural addition to any Synthesizer system since it provides an electro-mechanical equivalent to the delays and echos that define the accoustics of a large auditorium. The 4712 Reverb Module optimizes control flexibility by allowing for the mixing of two separate input signals as well as post-mixing of the input signals with the processed reverb signal. Front panel switch allows for instantaneous, pop-free termination of reverb effects without affecting normal signal flow through the module.

SPECIFICATIONS

POWER REQUIREMENTS:	+ 9v. @ 3.5 ma. - 9v. @ 3.5 ma.
INPUTS:	2; mixing
INPUT IMPEDANCE:	100K nom.
OUTPUT IMPEDANCE:	less than 1K
REVERBERATION TIME:	3 sec. nom.

SOLDERING

Use care when mounting all components. Use only rosin core solder (acid core solder is never used in electronics work). A proper solder joint has just enough solder to cover the round soldering pad and about 1/16 inch of the lead passing through it. There are two improper connections to beware of: Using too little solder will sometimes result in a connection which appears to be soldered but actually there is a layer of flux insulating the component lead from the solder bead. This situation can be cured by re-heating the joint and applying more solder. If too much solder is used on a joint there is the danger that a conducting bridge of excess solder will flow between adjacent circuit board conductors forming a short circuit. Unintentional bridges can be cleaned off by holding the board up-side down and flowing the excess solder off onto a clean, hot soldering iron.

Select a soldering iron with a small tip and a power rating not more than 35 watts. Soldering guns are completely unacceptable for assembling transistorized equipment because the large magnetic field they generate can damage solid state components.

CIRCUIT BOARD ASSEMBLY

- () Prepare for assembly by thoroughly cleaning the conductor side of the circuit board with a scouring cleanser. Rinse the board with clear water and dry completely.

Solder each of the fixed resistors in place following the parts placement designators printed on the circuit board and the assembly drawing figure 1. Note that the fixed resistors are non-polarized and may be mounted with either of their two leads in either of the holes provided. Cinch the resistors in place prior to soldering by putting their leads through the holes and pushing them firmly against the board, on the conductor side of the board bend the leads outward to about a 45° angle. Clip off each lead flush with the solder joint as the joint is made.

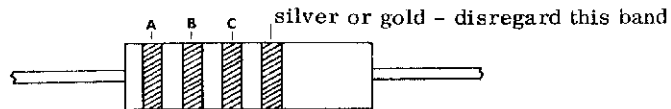

DESIGNATION	VALUE	COLOR CODE A-B-C
() R1	100K	brown-black-yellow
() R2	100K	brown-black-yellow
() R3	100K	brown-black-yellow
() R4	100K	brown-black-yellow
() R6	1 Meg ohm	brown-black-green
() R7	47K	yellow-violet-orange
() R8	150 ohm	brown-green-brown
() R9	2200	red-red-red
() R10	330 ohm	orange-orange-brown
() R12	2200	red-red-red
() R13	2200	red-red-red
() R14	270K	red-violet-yellow
() R15	330 ohm	orange-orange-brown
() R16	270 ohm	red-violet-brown
() R17	270 ohm	red-violet-brown

Install the ceramic disk capacitors. Without exception the value will be marked on the body of the part.

DESIGNATION	VALUE
() C1	15 pf.
() C2	15 pf.

Up to this point all components have been non-polarized and either lead could be placed in either of the holes provided without affecting the operation of the unit. Electrolytic capacitors are polarized and must be mounted so that the "+" lead of the capacitor goes through the "+" hole in the circuit board. In the event that the "-" lead of the capacitor is marked rather than the "+" lead it is to go through the unmarked hole in the circuit board.

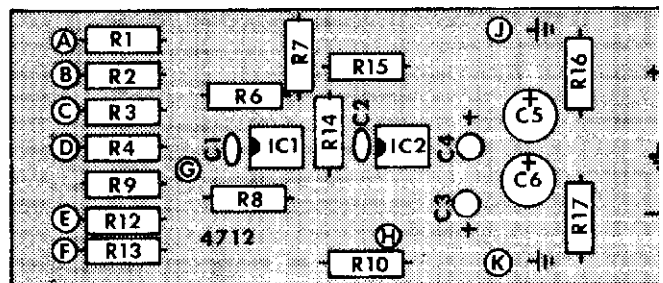

Figure 1 Parts Placement

Note that the operating voltage (v.) specified for a capacitor is the minimum acceptable rating. Capacitors supplied with specific kits may have a higher voltage rating than that specified and may be used despite this difference. For instance, a 100 mfd. 25v. capacitor may be used in place of a 100 mfd. 16v. capacitor without affecting the operation of the circuit.

Mount the following electrolytic capacitors and solder them in place. The values, voltage rating and polarization are marked on the body of the part.

DESIGNATION	VALUE
() C3	2.2 mfd. 6v.
() C4	2.2 mfd. 6v.
() C5	100 mfd. 10v.
() C6	100 mfd. 10v.

Mount the integrated circuits. Note that the orientation of the integrated circuit is keyed by a notch at one end of the case which aligns with the semi-circular key on the designator printed on the circuit board. Use particular care when installing this part, like any other semi-conductor it is heat sensitive and should not be exposed to extraordinarily high soldering temperatures. Make sure that the orientation is correct before soldering. Once the unit is in place it cannot be removed without destroying it.

DESIGNATION	TYPE NO.
() IC-1	748 op-amp
() IC-2	748 op-amp

In the following steps wires will be soldered to the circuit board which will later connect to the front panel controls and jacks. At each step prepare the wire by cutting it to the specified length and stripping 1/4 inch of insulation from each end of the wire. "Tin" each end of the wire by twisting the exposed strands tightly together and melting a small amount of solder into the wire.

Using the wire provided make the following connections to the circuit board.

- | | |
|---------------------------------------|---------------------------------------|
| () a 2 1/2 inch length to point "A". | () a 4 inch length to point "E". |
| () a 2 inch length to point "B". | () a 4-1/4 inch length to point "F". |
| () a 4-1/4 inch length to point "C". | () a 1-3/4 inch length to point "G". |
| () a 5 inch length to point "D". | () a 4-1/2 inch length to point "H". |

THIS COMPLETES ASSEMBLY OF THE 4712 CIRCUIT BOARD. Temporarily set the circuit board aside and proceed to the mounting of the front panel controls and jacks.

Place the front panel face down on a soft rag to prevent marring the finish.

Note that in a later step the ground lugs (lug #2) of miniature phone jacks J1 and J2 will be soldered together. Make sure that these lugs are adjacent to one another before tightening the nuts on these jacks. (see figure 2 foldout on page 5)

- () Mount the miniature phone jack J1 using the nut provided. Orient as illustrated in figure 2.
- () In a similar manner mount miniature phone jack J2. Orient as illustrated.
- () In a similar manner mount miniature phone jack J3. Orient as illustrated.
- () Using two 4-40 X 1/4 inch machine screws and two 4-40 nuts mount the slide switch S-1 in the position shown in figure 2.
- () Mount 500K ohm potentiometer R5 in the location shown in figure 2. Use two 3/8 inch nuts, one behind the front panel as a spacer and the second on the front side of the panel to secure the potentiometer. Adjust the rear nut so that none of the threaded shaft of the control is exposed when the front nut is tightened down. This will allow the control knob, which will be mounted in a later step to seat as closely as possible to the front panel. Orient as illustrated.
- () In a similar manner mount 5K ohm potentiometer R11. Orient as illustrated.

In the following steps the insulated wire remaining will be used to make connections between the front panel controls and jacks. Unless otherwise instructed, wires should be prepared by cutting them to the specified length, stripping 1/4" of insulation from each end and twisting and tinning the exposed strands.

- () Using a 4 inch length of insulated wire make the connection between lug #2 of S-1 and lug #3 of R11. Solder the connection at S-1 only.
- () Using a 2 inch length of insulated wire make the connection between lug #2 of R5 and lug #2 of R11. Solder the connection at R5 only.
- () Using a 2-3/4 inch length of insulated wire make the connection between lug #2 of R11 and lug #2 of J3. Solder the two wires at lug #2 of R11 but DO NOT SOLDER the connection at J3 at this time.
- () Using a 2 inch length of insulated wire make the connection between lug #2 of J3 and lug #2 of J2. Solder the two wires at lug #2 of J3 only.
- () Using a 1-1/2 inch length of insulated wire make the connection between lug #2 of J1 and lug #1 of S-1. DO NOT SOLDER.
- () Bend lug #2 of J2 and lug #2 of J1 slightly so that they touch each other.
- () Solder lug #2 of J2 and lug #2 of J1, along with the wires connected to these two lugs, together.

The front panel may now be bolted to the circuit board as follows:

- () Fasten the two "L" brackets to the front panel using one 4-40 X 1/4 inch machine screw, two lockwashers and one 4-40 nut on each bracket. Note that the unthreaded hole in the "L" bracket is used in this operation as shown in figure 3.
- () Fasten the circuit board to the front panel "L" brackets by passing a 4-40 X 1/4 inch machine screw up through the holes in the circuit board and threading them into the threaded holes in the "L" brackets. Securely tighten all screws.

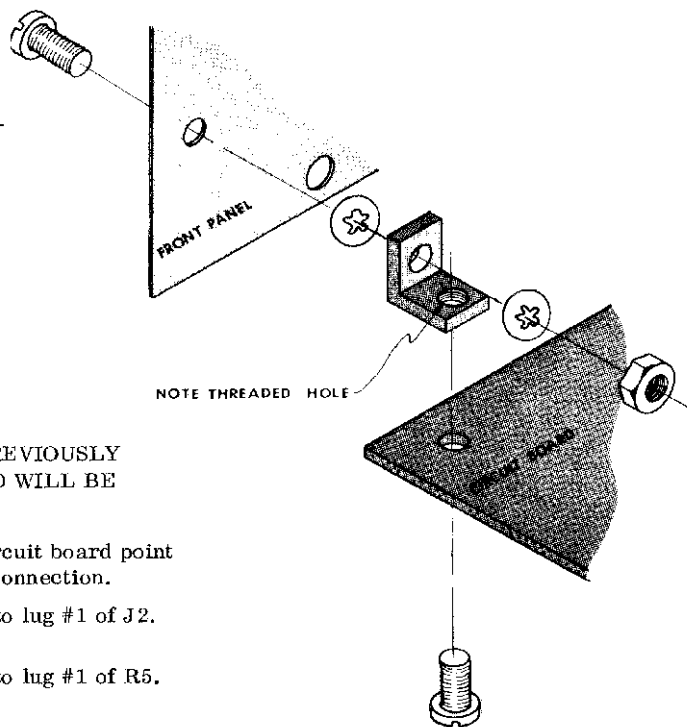

Figure 3 - Mounting Front Panel

IN THE FOLLOWING STEPS WIRES PREVIOUSLY CONNECTED TO THE CIRCUIT BOARD WILL BE CONNECTED TO THE FRONT PANEL.

- () Connect the wire coming from circuit board point "A" to lug #1 of J1. Solder this connection.
- () Connect the wire from point "B" to lug #1 of J2. Solder this connection.
- () Connect the wire from point "C" to lug #1 of R5. Solder this connection.
- () Connect the wire from point "D" to lug #3 of R5. Solder.
- () Connect the wire from point "E" to lug #1 of R11. Solder.
- () Connect the wire from point "F" to lug #3 of R11. Solder two wires at this connection.
- () Connect the wire from point "G" to lug #1 of S-1. Solder two wires at this connection.
- () Connect the wire from point "H" to lug #1 of J3. Solder.
- () Locate the 3 foot length of coaxial cable terminating in molded RCA type phono connectors and cut this cable into two equal 18 inch lengths.
- () Prepare both lengths of the above cable by stripping away 3/4 inch of the outer insulating sleeve to expose the shielding wire. Twist the shielding wire strands together and tin them. When tinned, cut away 1/2 inch of the shield so that only a stub 1/4 inch long remains. Strip 1/4 inch of the insulation from the inner conductor and twist and tin the exposed strands.

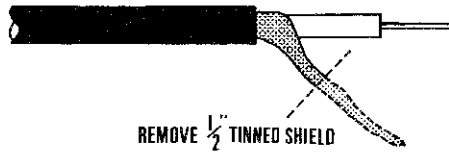

Figure 4 - Coax Preparation Detail

- () Insert the inner conductor of one of the previously prepared lengths of co-ax into point "K" on the circuit board and solder. Insert the shield wire into the nearest point marked " $\frac{1}{2}$ " and solder.
- () Insert the inner conductor of the remaining length of co-axial cable into point "J" and solder. Insert the shield wire into the nearest point marked " $\frac{1}{2}$ " and solder.
- () Rotate all control shafts fully counter-clockwise as viewed from the front of the panel.
- () Once the control knobs are pushed onto their shafts they will be difficult to remove. Before installing the knobs align the pointer on the top of each knob so that it points to the seven o'clock position of an imaginary clock. Push the knob onto the shaft firmly.
- () Three flea clips have been included to facilitate power supply connections. Insert these clips into the holes at the end of the circuit board marked "+", "-", and " $\frac{1}{2}$ ". Note that these clips are a tight fit and it may be necessary to bend the narrow end of the clips slightly to fit the holes.

THIS COMPLETES ASSEMBLY OF THE 4712 REVERB MODULE. Proceed now to the installation of the reverb spring.

NOTE: If you wish to mount the reverb spring inside the 2720 case slight clearance problems might be encountered. We suggest, if the spring is to be mounted here, that it be mounted anywhere to the right of the 2720-8B sample and hold circuit board and immediately above the 2720-8 voltage divider circuit board with the RCA phono jacks facing up. Slight re-positioning of the voltage divider circuit board may be required. Tubing has been supplied to place over any of the circuit board flea clip power connections that might come in contact with the reverb spring. (see figure 5)

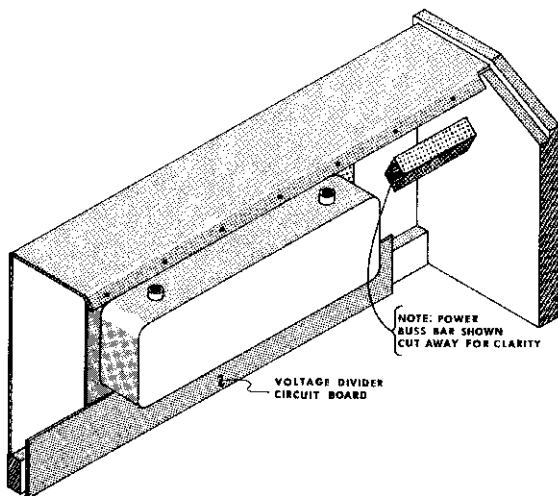

Figure 5 - Mounting the Reverb Spring

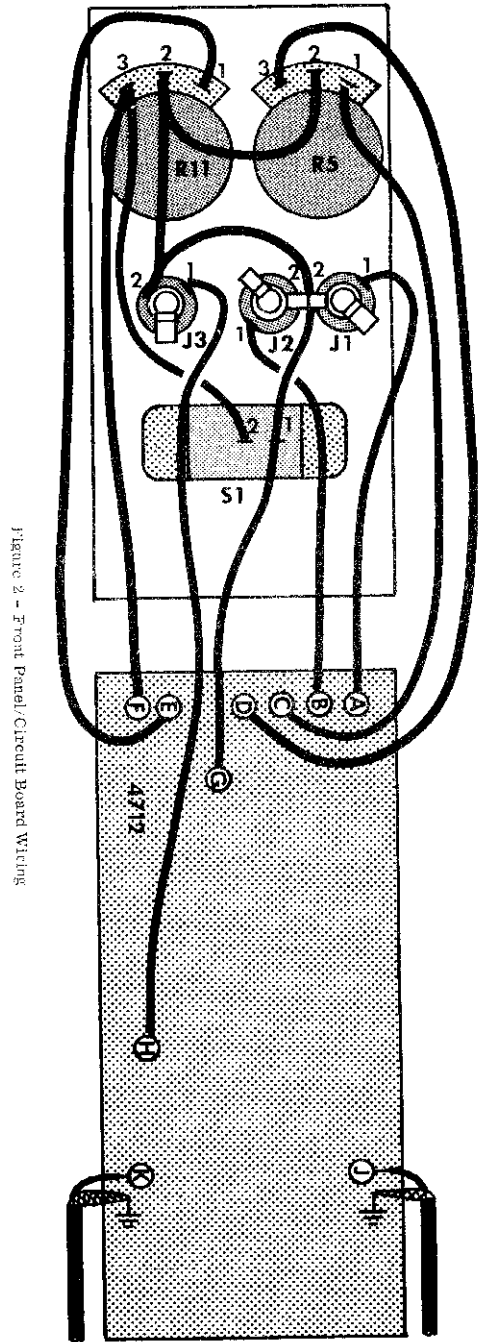

Figure 2 - Front Panel/Circuit Board Wiring

If the reverb spring is to be mounted in the 4760 Wing Cabinet it should be mounted anywhere on the back of the case high enough to clear the module circuit boards. NOTE: Sufficient clearance does not exist to mount the spring behind the 4780 Sequencer module or 2720-14 Sine converter/PWM.

- () Determine where you wish to mount the reverb spring and drill four $\frac{3}{16}$ inch holes as shown in figure 6.

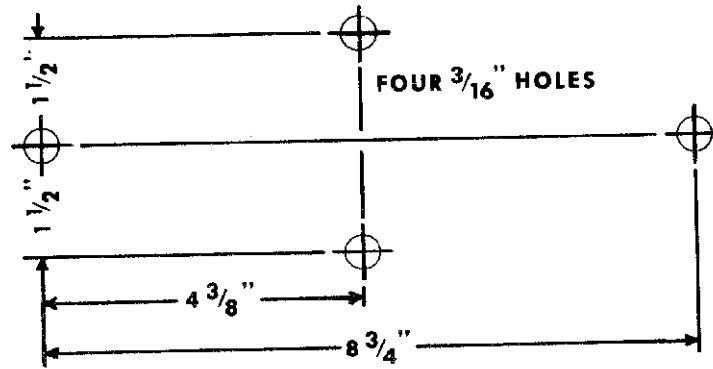

Figure 6 - Reverb Spring Mounting Hole Drilling Template

- () Using the four 8-32 X $\frac{1}{2}$ inch machine screws, four 8-32 nuts and four #8 lockwashers provided mount the reverb spring as shown in figure 7.

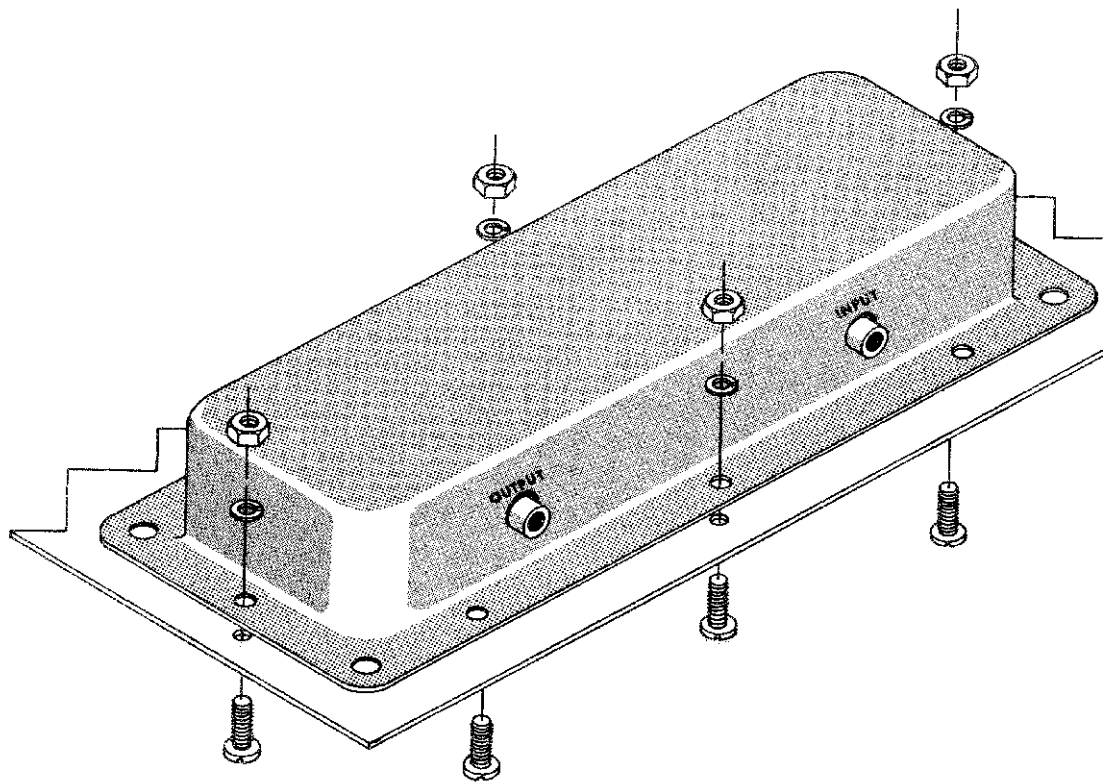

Figure 7 - Fasten reverb spring in place with #8 hardware

- () Connect the co-axial cable coming from circuit board point "J" to the jack mounted on the reverb spring housing marked "input".
- () Connect the co-ax from point "K" to the jack marked "output".

THIS COMPLETES CONSTRUCTION OF THE 4712 REVERB.

TESTING

The 4712 Reverb may be tested using only an audio signal source rich in harmonics (the pulse output of the 2720-2 VCO will work fine), an audio amplifier and any suitable power supply capable of producing +9v. and -9v.

Connect the power supply to the power connections at the rear edge of the circuit board; "+9" to 9v., ground to "0" and "-9" to -9v. Rotate both controls fully counter-clockwise as viewed from the front of the front panel and place the "rev" switch in the "out" position. Connect the 2720-2 or other signal source to the input labeled "1" and connect the output of the 4712 to the high level input of your amplifier. Confirm that with the controls set as specified the signal passes through the 4712 with little or no gain or attenuation and that no reverberation is added. Rotate the input control clockwise and note that there is little change in the level of the signal for the first half of this control's rotation. Clockwise rotation beyond the half-way point should produce increasing attenuation of the signal until, at the limit of the knob's rotation, the signal is off. Remove the signal from the #1 input and place it in the #2 input. Observe that the volume of the tone from the amplifier is approximately the same as it was with the control fully counter-clockwise and the signal applied to the #1 input. Rotate the input control counter-clockwise and observe that there is a reduction in volume similar to that experienced with the signal applied to the #1 input.

Rotate the input control fully clockwise and slide the "rev" switch to the "in" position. Confirm that the signal is still passing with no reverb effects. NOTE: Reverberation effects are most noticeable on signals that are changing either in frequency or amplitude - during the following tests vary the frequency of the signal source when listening for reverb so that the effect can be more clearly heard. Rotate the output control knob in a clockwise direction and observe that as the control is advanced the reverb effect becomes progressively more pronounced until at the clockwise limit the sound is totally reverb without any non-processed signal passing at all.

THIS COMPLETES THE TESTING OF THE PAIA 4712 REVERB MODULE.

USING THE 4712 REVERB MODULE

The front panel graphics of the 4712 Reverb module divide the controls into roughly three groups: INPUT, OUTPUT and the REVERB termination switch. Operation of these controls is as follows:

INPUT- The input section of the panel consists of a single control knob and two miniature phone jack inputs. The control knob is a pan pot which allows the user to select either #1 or #2 input or to mix the two inputs as needed. Rotating the input control fully counter-clockwise allows only the input signal presented to input #1 to pass through the module while any signal at input #2 is not allowed to pass. Rotating the control in a clockwise direction increases the percentage of the #2 signal present in the output until the control is approximately at its mid-range setting. The predominant effect of further rotation is to decrease the amount of the #1 signal while leaving the #2 signal essentially constant.

OUTPUT- In the same way that the single control in the input section of the module selected one of the two inputs and allowed for their mixing, the control in the output section of the panel selects either the unaltered signal without any reverberation processing when set to "norm" or only the signal after it has passed through the reverb spring assembly when set to "rev". Intermediate setting of the control produces a mixture of the processed and non-processed signals.

REV- The slide switch marked "in"-"out" provides a convenient means of eliminating the reverb effects when desired without having to change the setting of the "norm/rev" output control. Sliding the switch to the "out" position terminates the reverb effects without altering the level of the non-process signal.

The 4712 is used in essentially the same way that it was tested. One or more signal sources are connected to the input jacks, the input control is set to the desired mix of the signals (or set fully to the input being used if only one signal source is being processed), the output is routed to the synthesizers external amplifier (or to other processing elements - VCA's, filters, etc.) and the output control set for the desired mix of reverb processed and non-processed signal.

A variety of effects can be achieved by altering the position of the reverb module in the audio chain. For example, figure 8 shows schematically a typical patch which has a keyboard controlled VCO feeding a VCA under the control of an ADSR for envelope shaping with the output of the VCA going to the Reverb unit and then to the amplifier or recorder being used. This is "typical" because it simulates the effect of some instrument (depending on VCO waveform selection, ADSR settings, etc.) being played in an auditorium. The VCO and VCA in effect simulate the instrument while the Reverb simulates the acoustics of the hall. Percussion effects played with this patch will have a very characteristic "echo" quality that will cause some reverberating sound to be present for a short time after the ADSR has turned the VCA off. Sustain instrument simulations will have the same effect but it will be masked somewhat by the sustain interval.

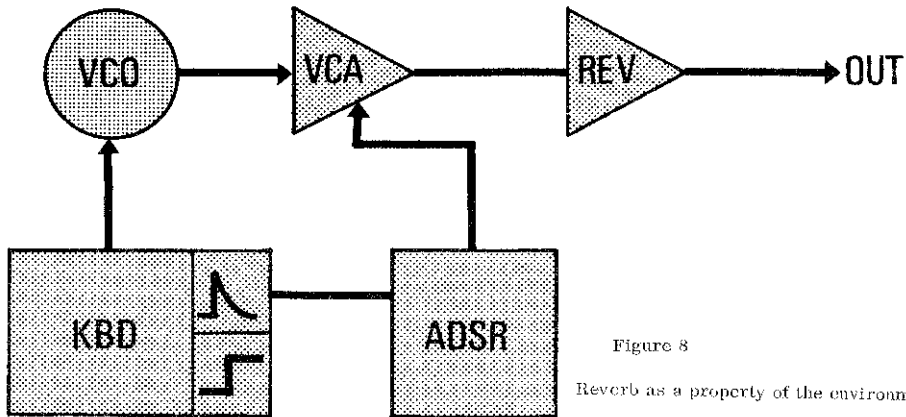

By interchanging the VCA and Reverb as shown in figure 9 we have generated an entirely new situation. Even if all of the controls of this patch are set exactly as they were before, we now have some kind of new instrument simulation that has reverb as a quality of the instrument rather than quality of the environment. Percussion envelopes played on this new patch will not have the reverberating "echo" that the first patch had because when the ADSR turns the VCA off it kills the reverberation along with the rest of the sound.

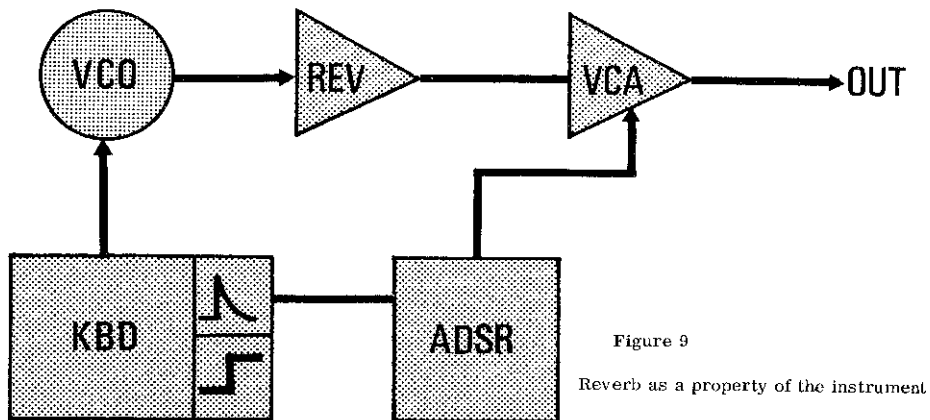

There are a few things to beware of. Like most PAIA 2720 and 4700 series synthesizer modules, the input of the 4712 is direct coupled and signal sources which have a fixed D.C. voltage level present at their outputs should be capacitively coupled to the 4712 input by placing a small capacitor (.22 mfd typical) in series with the input.

The 4712 is designed to operate with a moderately high level signal (.5v. peak to peak nominal) and signal levels lower than this - such as the output of electric guitars - may be subject to hum pick-up. It is suggested that a PAIA 2720-12 Inverter/Buffer or other suitable pre-amplifier with approximately 20 db. gain be used to buffer the instrument from the reverb module. Route the output of the instrument first into the 20 db. input of the buffer, then connect the output of the buffer to one of the reverb's inputs.

DESIGN ANALYSIS

Reverb Spring Assembly--The reverb spring assembly supplied with the PAIA 4712 Reverb Module is a standard type manufactured by a subsidiary of one of the country's leading organ manufacturers. It consists of two electro-mechanical transducers mechanically connected to one another by two coil springs.

The transducers consist of small permanent magnets which are suspended in an air gap of a laminated core transformer. When a signal current is supplied to the transformer winding it gives rise to a magnetic flux in the core. At the air gap, the effect of this magnetic field is to produce a torsional force on the permanent magnet that causes the magnet to rotate slightly. The resulting pressure wave propagates the length of the spring as a rotational flexure until it reaches the receiving transducer where two things happen. First, the permanent magnet at the receiving transducer is twisted slightly and the resulting change in magnetic flux in the core of the transducer induces a signal voltage in the winding associated with that core. Also, the mechanical termination at the receiving transducer does not absorb all of the incident pressure wave so that some energy is reflected back down the spring. When this reflected wave reaches the input transducer, some of it is reflected again to begin the journey down the helix to appear delayed in time as a second output signal. The reflecting process happens again and again causing the echo-like reverberation.

A second and equally important effect that comes into play in the total reverb sound is the frequency response characteristics of the mechanical assembly. Like the acoustics of a large hall of complex configuration, the mechanical reverb assembly has a multitude of resonant and anti-resonant peaks as shown in the plot of frequency response shown in figure 10.

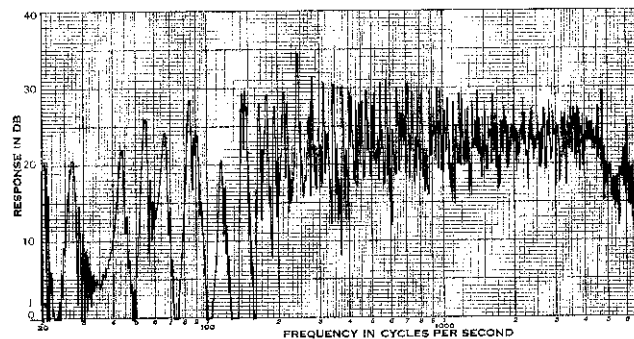

Figure 10 - Reverb Frequency Response

Driver Module--A schematic of the driver module electronics is shown in figure 11. Signals from inputs #1 and #2 are applied to resistors R1 and R2 respectively which in conjunction with resistors R3 and R4 and potentiometer R5 form a variable attenuation summing network at the input of operational amplifier IC1. As the input control is rotated from one extreme of its rotation to the other it alternately grounds the junctions of R1 and R3 or R2 and R4. When either of these junctions is at ground potential, any input signal that would otherwise appear at this point is grounded and makes no contribution to the output of the amplifier stage. In intermediate positions, the input resistors R1 and R2 along with the portion of the potentiometer R5 which is between ground and the points labeled "C" and "D" form a voltage divider that causes one level to increase while the other is decreasing.

The output of this input mixing/buffering amplifier connects back to the input of the reverb spring assembly and to the wodge divider consisting of R7 and R8.

In the same way that R1, R2, R3, R4 and R5 formed a mixing input for IC1, so R9, R10, R12, R13 and potentiometer RH form an identical input section for IC2. Either the reverb processed signal at point "K" or the non-processed signal present at the junction of R7 and R8 can be selected by rotating the control RH. The selected signals are amplified by the operational amplifier IC2 and coupled to the output jack by the non-polarized capacitor comprising the back to back electrolytic capacitors C3 and C4.

The "in"- "out" switch terminates any reverb effects by shorting the junction of R10 and R13 directly to ground.

Resistors R16 and R17 in conjunction with electrolytic capacitors C5 and C6 decouple the module from the power supply and provide further filtering of the supply voltage.

The output of this input mixing/buffering amplifier connects back to the input of the reverb spring assembly and to the wodge divider consisting of R7 and R8.

In the same way that R1, R2, R3, R4 and R5 formed a mixing input for IC1, so R9, R10, R12, R13 and potentiometer RH form an identical input section for IC2. Either the reverb processed signal at point "K" or the non-processed signal present at the junction of R7 and R8 can be selected by rotating the control RH. The selected signals are amplified by the operational amplifier IC2 and coupled to the output jack by the non-polarized capacitor comprising the back to back electrolytic capacitors C3 and C4.

The "in"- "out" switch terminates any reverb effects by shorting the junction of R10 and R13 directly to ground.

Resistors R16 and R17 in conjunction with electrolytic capacitors C5 and C6 decouple the module from the power supply and provide further filtering of the supply voltage.