

The MOOG

# sonic six

TECHNICAL SERVICE MANUAL

by R.J. Folkman

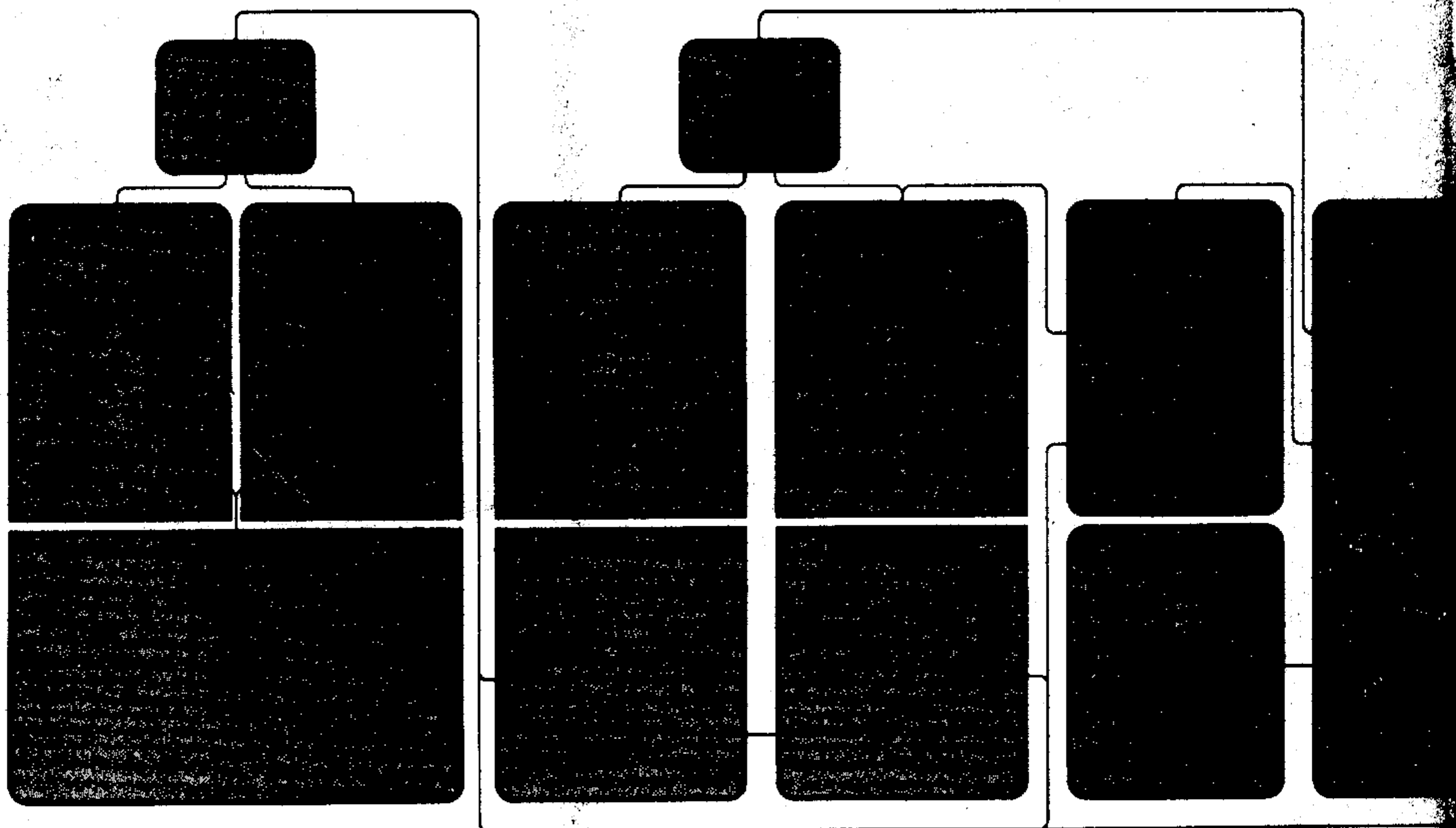

**moog**

MUSIC INC.

the first sound in synthesizers

**\$10.00**

SONIC SIX  
TECHNICAL SERVICE MANUAL

For SONIC SIX Units  
Serial No. 1300  
(and above)

SONIC SIX

TECHNICAL SERVICE MANUAL

CONTENTS

<u>SECTION</u>	<u>TITLE</u>	<u>PAGE</u>
I	Precautionary Measures	1
II	Sub-Assembly Descriptions	2
III	Block Diagram	7
IV	Trouble Analysis Guide	8
V	Sub-Assembly Locations	15
VI	Panel and Sub-Assembly Removal	16
VII	Adjustment Procedures and Locations	19
VIII	Keyboard Maintenance	35
IX	Schematic Diagrams	37
X	Component Location Charts	40
XI	Replacement Parts	43
XII	Modifications	48
XIII	Ordering and Shipping Instructions	49

# SONIC SIX

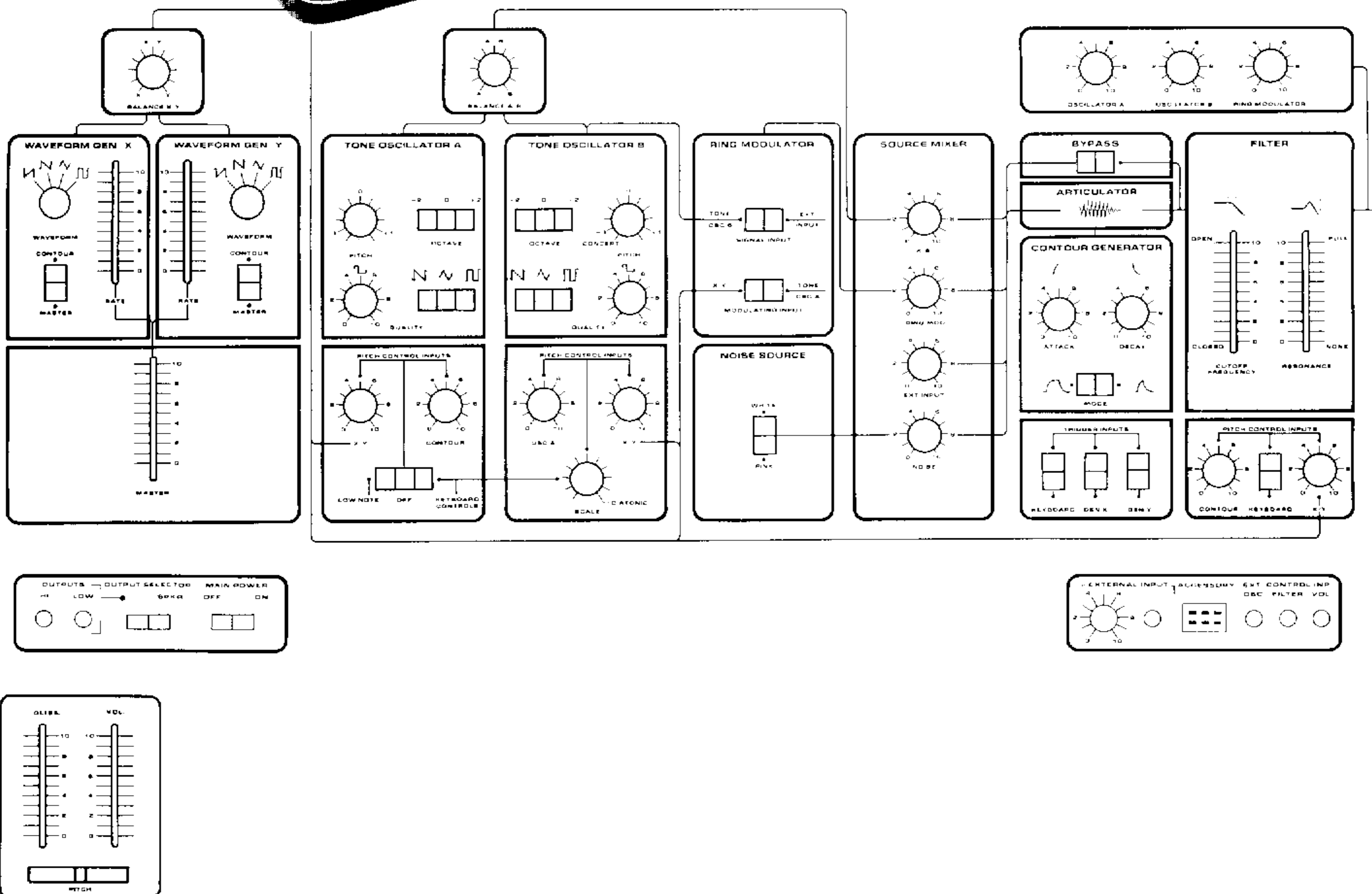
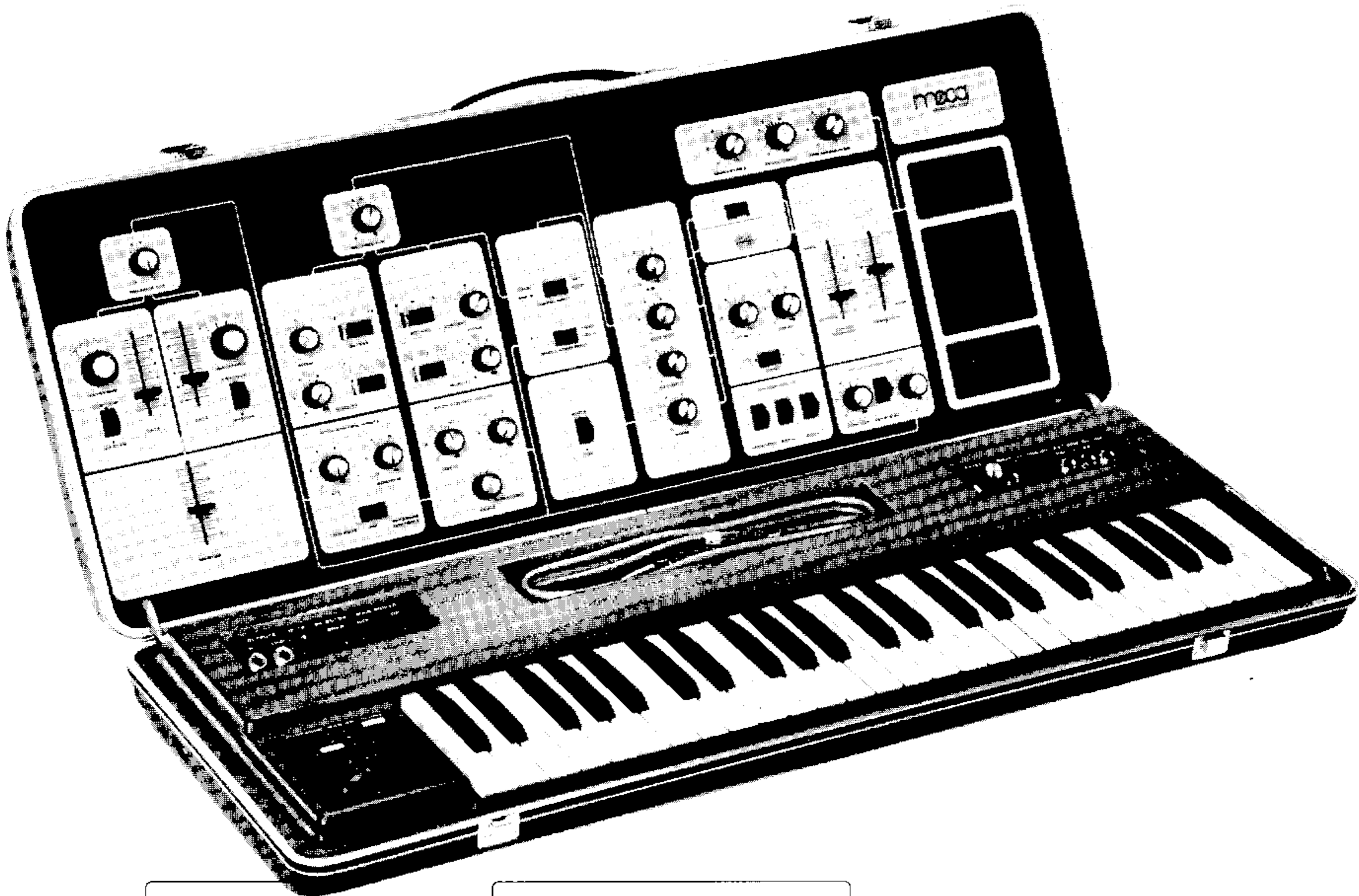

SECTION I: Precautionary Measures

In the "SONIC SIX", as in any line operated electrical device, there are potential shock hazards. All lethal or hazardous voltages are confined to the area around the power input panel. Always unplug the instrument while servicing the lower portion, or replacing the fuse.

If a fuse blows, replace it only with the proper value as indicated on the label near the fuse holder. If the fuse continues to blow, it is an indication that a definite electrical problem has developed. Never try a larger fuse; this may result in further internal damage. Make sure the line voltage selector switch is in the proper position.

Do not make adjustments at random. Many adjustments are critical and should be made in accordance with the procedures outlined herein. If a sub-assembly is found to be defective and is still in warranty, we recommend exchanging it rather than attempting to repair it.

SECTION II: SUB-Assembly Description

93-119 Oscillator (Board 1)

This assembly contains two regulated power supplies, two tone oscillators, and two modulating oscillators. In addition, controls for pitch, waveform selection, and modulation are located on this circuit board.

The regulated power supplies provide the plus and minus 15 volts required by all other circuits. These supplies utilize standard voltage regulator integrated circuits in conjunction with series pass power transistors for high current handling capability. Both supplies employ current limiting and are short-circuit proof.

The two tone oscillators are completely independent, non-synchronous, and use identical circuits. Each oscillator is a dual slope integrator which produces a triangle wave. The frequency is exponentially proportional to the control voltage. Linear control voltages are converted to exponential currents by a grounded base transistor configuration. These transistors are part of a heated chip which is operated at a constant elevated temperature to increase thermal stability. The exponential current is then converted to an exponential voltage which is used to voltage control the pitch of the tone oscillators.

SECTION II: Sub-Assembly Description (Continued)

The basic triangle wave is then processed to produce sawtooth and square waveforms.

The X-Y modulating oscillators are also dual slope integrators with some component values changed to reduce their frequency. Each oscillator produces four waveforms. The selected waveform outputs of X and Y can be mixed to produce complex modulating signals. Oscillator rates are controlled independently with the individual rate controls and jointly via a MASTER RATE control.

93-120 Signal Processing (Board 2)

This assembly contains the voltage controlled filter, articulator, contour generator, keyboard circuit, ring modulator, noise source, two mixers, a voltage controlled amplifier (VCA) and the output power amplifier. In addition, operating controls for these circuits are located on this circuit board.

The voltage controlled amplifier utilizes a programmable gain IC amplifier, which receives its control current from the VOLUME control and the EXTERNAL VOLUME CONTROL input jack.

The filter is a voltage controlled low pass type which employs the Moog patented transistor ladder network. It is capable of regeneration (oscillation) over a wide frequency

SECTION II: Sub-Assembly Description (Continued)

range. The filter scale factor is adjustable to enable the filter to track the keyboard.

The articulator uses the same type programmable gain IC amplifier as the VCA. It receives its control voltage from the contour generator.

The contour generator employs a dual gate latch to switch from the attack state to the decay state. Attack time is controlled by varying a resistance in the charge path of a timing capacitor. When the timing capacitor reaches a predetermined potential, a comparator resets the dual gate latch to begin the decay cycle. Decay time is controlled by varying a resistance in the discharge path of the timing capacitor.

The keyboard current source provides a precise DC voltage across the keyboard resistance string. In addition to this DC level, an AC signal, at approximately 8 KHz. is superimposed upon the fixed current in the resistance string. This AC signal is used to generate gate and trigger voltages by amplifying the 8 KHz. and rectifying it to obtain a DC switching voltage. This DC voltage drives a voltage comparator which generates gate and trigger 1. A second trigger is produced when two or more keys are depressed, shorting out a portion of the keyboard resistance. This condition causes a



SECTION II: Sub-Assembly Description (Continued)

voltage change at the output of the keyboard current source, since the keyboard resistance is in the feedback circuit. This change is fed to a comparator which produces the second trigger.

When a key is depressed, a point on the keyboard resistor string contacts the keyboard buss. The keyboard buss is connected to a holding capacitor and the keyboard amp. The holding capacitor is charged to a level equal to that of the keyboard buss. When the key is released, this capacitor holds the voltage level to which it was last charged, acting as a sample/hold circuit. To reduce charge "bleed-off", a high input impedance FET Op-Amp is used. The output of this FET circuit is the pitch 1 control voltage. This voltage is applied to the GLISSANDO control which varies the charge time of the glissando capacitor. A voltage follower is then used to provide a low impedance for driving the filter and oscillator pitch control inputs. The pitch 2 control voltage is the difference between pitch 1 and keyboard low end voltages.

The ring modulator uses a balanced modulator chip. This accepts two AC signals, and in conjunction with an output summing amplifier, supplies an output which is the sum and difference frequencies of the two original signals.

SECTION II: Sub-Assembly Description (Continued)

The noise generator utilizes a reverse biased emitter base transistor junction as its source. This signal is amplified and filtered to yield both white and pink noise outputs.

The output power amplifier is an integrated circuit which runs on the unregulated plus voltage. It powers the internal speaker and the headphone jack. The MONITOR output is taken ahead of the power amp. for better signal to noise ratio.

93-127 Pitch Bender (Board 3)

This assembly contains the master VOLUME control, the GLISSANDO control, the pitch bender amp, and the input rectifier diodes. The pitch bender amp has diode desensitizer circuits which provide a dead band when the pitch bender is in the spring return center position.



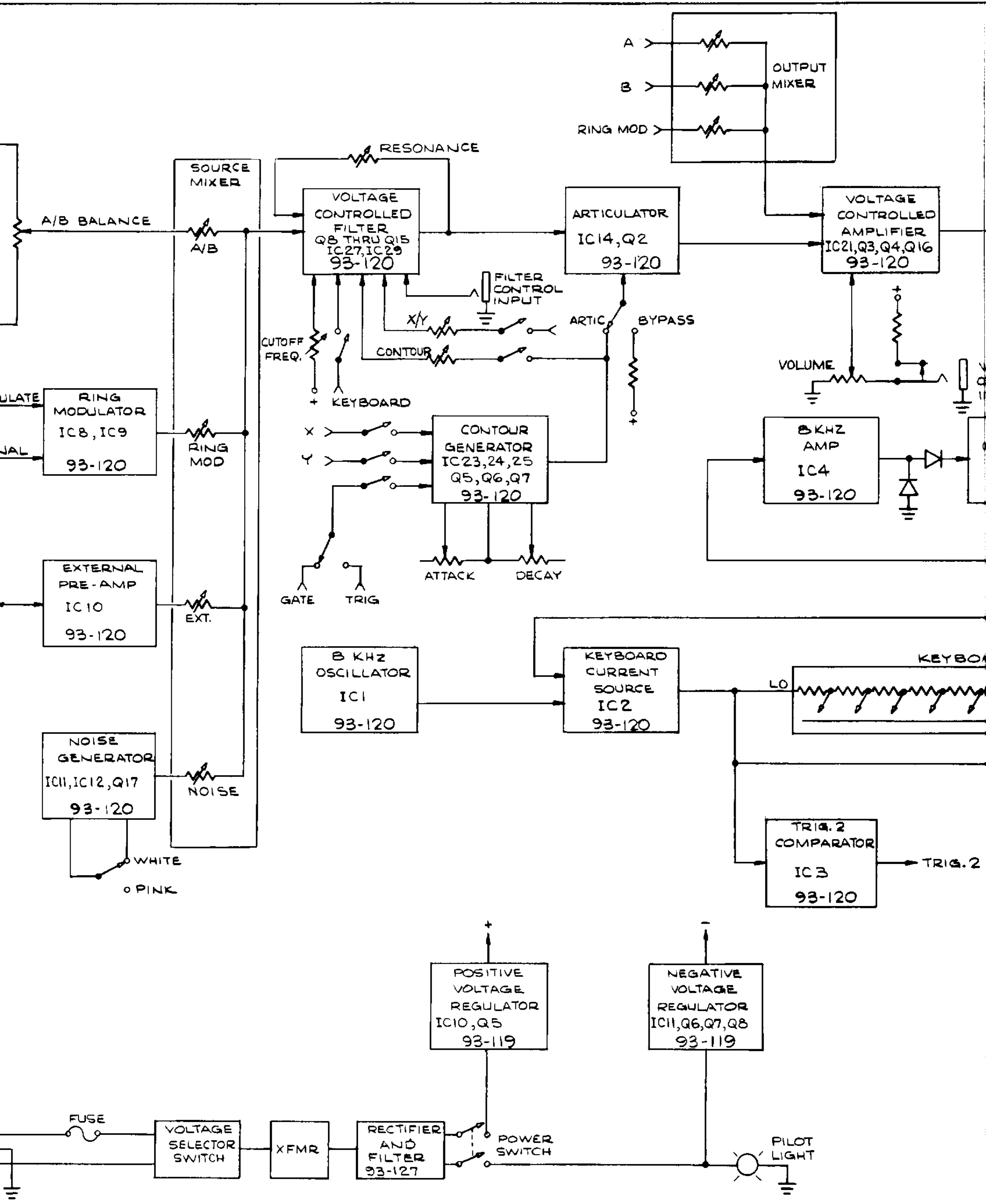

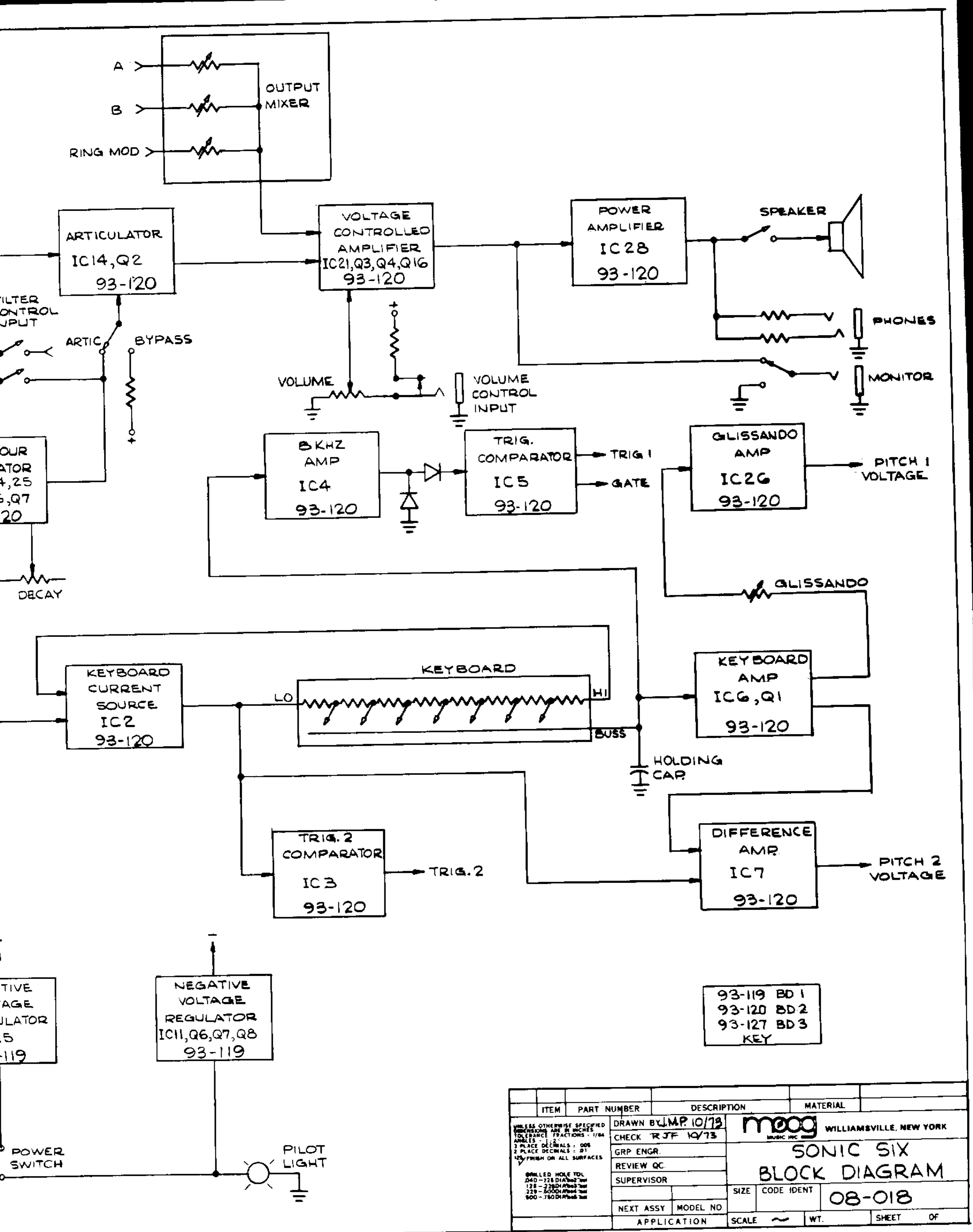

93-119 BD 1  
 93-120 BD 2  
 93-127 BD 3  
 KEY

ITEM	PART NUMBER	DESCRIPTION	MATERIAL
UNLESS OTHERWISE SPECIFIED DIMENSIONS ARE IN INCHES		DRAWN BY: J.M.P. 10/73	
TOLERANCE FRACTIONS: 1/64		CHECK: R.J.F. 10/73	
ANGLES: 45°		MOOG MUSIC INC. WILLIAMSVILLE, NEW YORK	
3 PLACE DECIMALS: .005		SONIC SIX	
2 PLACE DECIMALS: .01		BLOCK DIAGRAM	
15° FINISH ON ALL SURFACES		SIZE	CODE IDENT
DRILLED HOLE TOL: .040-.028 DIA/90° .125-.028 DIA/90° .225-.000 DIA/90° .500-.000 DIA/90°		08-018	
NEXT ASSY		MODEL NO.	SCALE
APPLICATION		WT.	SHEET OF

SECTION IV: Trouble Analysis Guide

Part A - General (Refer to Main Frame Schematic)

<u>Malfunction</u>	<u>Probable Cause</u>
Unit Dead (No Pilot Light)	<ol style="list-style-type: none"> <li>1. Blown Fuse</li> <li>2. Defective Power Transformer</li> <li>3. Defective Rectifier Diodes CR3-CR6</li> <li>4. Defective Power Switch</li> <li>5. Open Line Cord</li> </ol>
Unit Dead (Pilot Light On)	<ol style="list-style-type: none"> <li>1. Loss of Plus or Minus Power Supply (Board 1)</li> <li>2. Voltage Selector in wrong position</li> </ol>
Excessive Hum and Constant Modulation of all Signals	<ol style="list-style-type: none"> <li>1. Defective rectifier diode (Board 3)</li> <li>2. Open Filter Capacitor (Under Board 3)</li> <li>3. Defective voltage Regulator (Board 1)</li> <li>4. Broken Ground Wire</li> </ol>
PITCH BENDER Inoperative	<ol style="list-style-type: none"> <li>1. Defective IC1 on Board 3</li> <li>2. Open Pitch Bender Control R7</li> </ol>
PITCH BENDER works in one direction only	<ol style="list-style-type: none"> <li>1. Defective Diode CR1, CR2, CR7 or CR8 on Board 3</li> <li>2. Defective IC1 on Board 3</li> </ol>
Both Oscillators Radically off pitch	<ol style="list-style-type: none"> <li>1. Output of Pitch Bender is not at zero volts</li> <li>2. Defective IC24 - Board 1</li> </ol>
Noisy or Double Triggering	<ol style="list-style-type: none"> <li>1. Dirty Keyboard Contacts</li> <li>2. Keyboard Contacts out of Adjust- ment - See <u>Section VIII</u></li> </ol>

SECTION IV: Trouble Analysis Guide (Continued)

<u>Malfunction</u>	<u>Probable Defect</u>
Keyboard works backward	<ol style="list-style-type: none"> <li>1. Short from Keyboard Resistor String to grounded metal frame</li> <li>2. Defective Keyboard Current Source on Board 2</li> </ol>
GLISSANDO Control Inoperative	<ol style="list-style-type: none"> <li>1. Defective Control</li> <li>2. Open Glissando Capacitor (Board 2)</li> </ol>
VOLUME Control Inoperative	<ol style="list-style-type: none"> <li>1. Defective Control</li> <li>2. Defective VCA (Board 2)</li> </ol>
No Output from Speaker (Phones Jack OK)	<ol style="list-style-type: none"> <li>1. Defective Speaker</li> <li>2. Defective Speaker Switch</li> </ol>
No EXTERNAL Input	<ol style="list-style-type: none"> <li>1. Defective External Level Control</li> <li>2. Trouble in External Pre-Amp (Board 2)</li> </ol>
Inoperative Control Input	<ol style="list-style-type: none"> <li>1. Defective Jack</li> <li>2. Broken Harness Wire</li> </ol>
<u>Part B - Board 1 Malfunctions (Refer to Board 1 Schematic)</u>	
<u>Malfunction</u>	<u>Probable Defective Component</u>
MASTER RATE Control has no affect on Oscillator "X" or "Y"	<ol style="list-style-type: none"> <li>1. Master Rate Control (R1)</li> <li>2. Master Rate Amplifier (IC1)</li> </ol>

SECTION IV: Trouble Analysis Guide (Continued)

<u>Malfunction</u>	<u>Probable Defect</u>
OSCILLATOR "X" Dead	1. Q1, IC2, IC3, or CR1
OSCILLATOR "X" No Sawtooth Output	1. IC5
OSCILLATOR "X" No <u>Square Wave</u> Output	1. IC4
OSCILLATOR "X" Triangle is Non- Symmetrical	1. <u>X Low</u> Maladjusted (R13) 2. Q1
OSCILLATOR "Y" dead	1. Q2, IC6, IC7 or CR2
OSCILLATOR "Y" No Sawtooth Output	1. IC9
OSCILLATOR "Y" No <u>Square Wave</u> Output	1. IC8
OSCILLATOR "Y" Triangle is Non- Symmetrical	1. <u>Y Low</u> Maladjusted (R28) 2. Q2
TONE OSCILLATOR "A" dead	1. Q9, CR8, Q3, IC14, IC15, IC16, Q4 or IC25



SECTION IV: Trouble Analysis Guide (Continued)

<u>Malfunction</u>	<u>Probable Defect</u>
TONE OSCILLATOR "A" No Pitch Control from any source	1. IC12, IC13, or IC24
TONE OSCILLATOR "A" No <u>Square Wave</u> Output	1. IC16
TONE OSCILLATOR "A" No Sawtooth Output	1. Q4 or IC17
OSCILLATOR "A" AND "B" Running Low Frequency	1. IC24 2. Maladjustment of <u>Chip Temp</u> (R135)
TONE OSCILLATOR "B" dead	1. Q12, CR10, Q10, IC20, IC21, IC22, Q11 or IC26
TONE OSCILLATOR "B" No pitch control from any source	1. IC18, IC19 or IC24
TONE OSCILLATOR "B" No <u>Square Wave</u> Output	1. IC22
TONE OSCILLATOR "B" No Sawtooth Output	1. Q11 or IC23
Plus 15 Volt Supply too high	1. IC10 or Q5 2. Maladjustment of <u>+ADJ</u> (R38)

SECTION IV: Trouble Analysis Guide (Continued)

Malfunction	<u>Probable Defect</u>
Plus 15 Volt Supply too low	<ol style="list-style-type: none"> <li>1. IC10</li> <li>2. Short on +15 Volt Line</li> <li>3. Maladjustment of <u>+ADJ</u> (R38)</li> </ol>
Minus 15 Volt Supply too high	<ol style="list-style-type: none"> <li>1. IC11, Q6 or Q7</li> <li>2. Maladjustment of <u>-ADJ</u> (R43)</li> </ol>
Minus 15 Volt Supply too low	<ol style="list-style-type: none"> <li>1. IC11, Q6, Q7, Q8, CR11</li> <li>2. Short on -15 Volt Line</li> <li>3. Maladjustment of <u>-ADJ</u> (R43)</li> </ol>
<p><u>Part-C - Board 2 Malfunctions</u>      Refer to Board 2 Schematic</p>	
<u>Malfunction</u>	<u>Probable Defect</u>
No Output at Speaker or PHONES Jack (MONITOR Output OK)	<ol style="list-style-type: none"> <li>1. IC28</li> </ol>
No Output at Speaker PHONES OR MONITOR Jack	<ol style="list-style-type: none"> <li>1. IC21, Q3, Q4 or Q16</li> </ol>
VOLUME Control and EXT VOLUME CONTROL Input Inoperative	<ol style="list-style-type: none"> <li>1. Q3, Q4 or IC21</li> </ol>
ARTICULATOR does not function (BYPASS OK)	<ol style="list-style-type: none"> <li>1. No Input from Contour Generator</li> </ol>

SECTION IV: Trouble Analysis Guide (Continued)

<u>Malfunction</u>	<u>Probable Defect</u>
ARTICULATOR does not function (BYPASS dead)	1. IC14 or Q2
CONTOUR GENERATOR Inoperative	1. No Trigger from Keyboard Circuit 2. IC23, Q5, Q6, Q7, IC24, IC25, CR7
KEYBOARD will not trigger the Contour Generator	1. IC4, CR3, CR4, IC5, or IC1
KEYBOARD will not produce Second Trigger	1. IC3, CR1
KEYBOARD produces no pitch change	1. Q1, IC6, IC2 or IC26
KEYBOARD will not produce Second Note	1. IC7 or IC2
First and Second Note do not track	1. OSCILLATOR "A" and/or "B" not properly tuned 2. Maladjustment of <u>KB</u> Trimpot (R8)
FILTER will not regenerate (Artic Switch in Bypass)	1. Q14, IC29, Q8 thru Q13 2. Maladjustment of <u>Regen</u> trimpot (R171)
FILTER will not pass any signal	1. IC27, Q14, IC29, Q15 2. Maladjustment of <u>Pitch</u> trimpot (R160)

SECTION IV: Trouble Analysis Guide (Continued)

<u>Malfunction</u>	<u>Probable Defect</u>
FILTER will not track Keyboard when regenerating	1. Maladjustment of <u>Filter Scale</u> trimpot (R179)
RING MODULATOR dead	1. IC9 or IC8
RING MODULATOR has bleed through (Original signal getting through)	1. Maladjustment of <u>Signal Balance</u> trimpot (R39) 2. Maladjustment of <u>Mod Balance</u> trimpot (R43)
No NOISE (White or Pink)	1. Q17, IC11, IC12
NOISE Level low	1. Q17 2. Maladjustment of <u>Noise</u> trimpot (R55)
EXTERNAL Input dead	1. IC10
No GLIDE	1. Open C43
GLIDE Always present	1. IC26 2. GLISSANDO Control
Frequency Drifts after Key is released	1. Leaky FET Q1 2. Contamination of Keyboard Buss Circuitry 3. Leaky Capacitor C11

BOARD 1, 93-119

CABLE HAR  
74-25

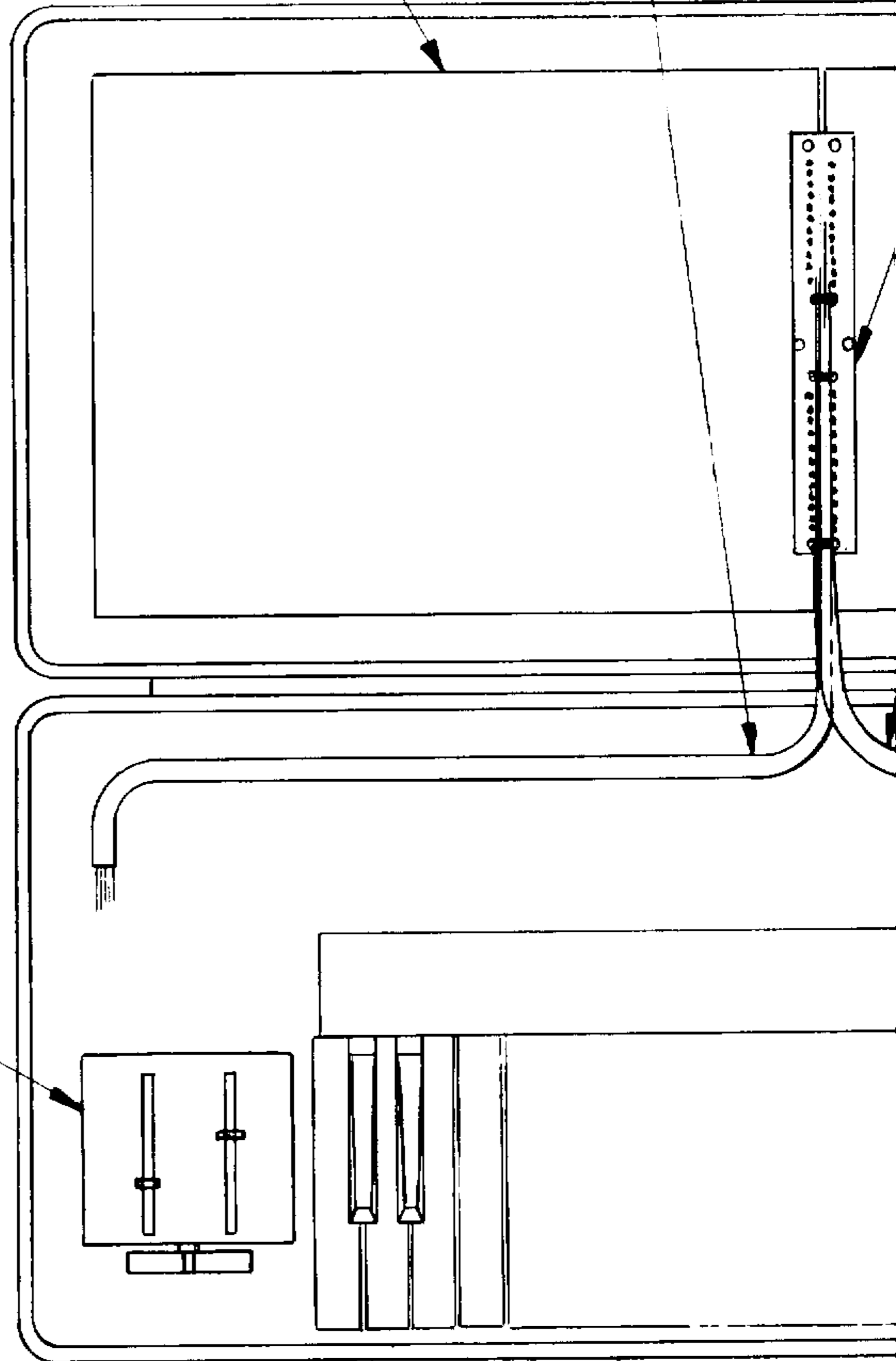

BOARD 3  
93-127

CABLE HARNESS  
74-253

BOARD 2,93-120

SPEAKER ASSEMBLY  
93-004

KEYBOARD  
93-008

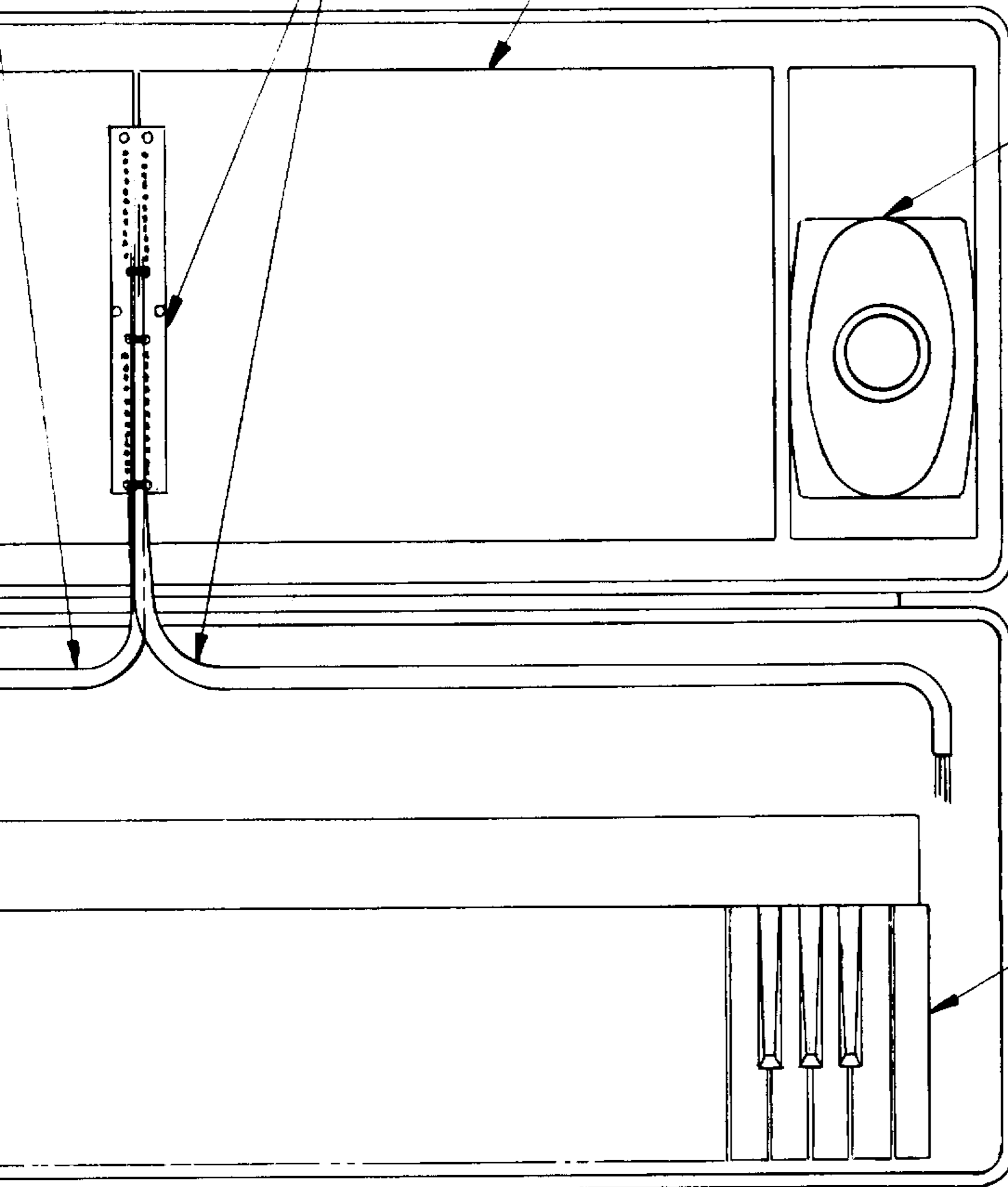

DRAWN BY A. BRIANNI 10-19-73		 WILLIAMSVILLE, NEW YORK	
CHECK RJF 10/73			
GRP ENGR.		SUB-ASSEMBLY LOCATIONS SONIC SIX	
REVIEW QC.			
SUPERVISOR			
	SONIC 6	SIZE	CODE IDENT
NEXT ASSY	MODEL NO.		
APPLICATION		SCALE ~	WT. ~
			SHEET

## SECTION VI: Panel and Sub-Assembly Removal

### "Control Panel" Removal

- A. Remove six screws, three at top and three at bottom of front panel.
- B. Hold hand in front of panel and slowly close the cover.
- C. Control panel will drop out of upper cover.
- D. Unplug cable harness from P/C Boards.

### "Lower Tray Cover" Removal

- A. Unplug the unit.
- B. Remove screw in the power cord storage well.
- C. Remove six screws around the perimeter of the lower tray cover.
- D. Remove knobs from VOLUME and GLISSANDO controls.
- E. Lift lower tray cover off.

### "Lower Tray" Removal

- A. Remove lower tray cover.
- B. Remove nine mounting screws on bottom of carrying case.
- C. Lift entire tray assembly out.

SECTION VI: Panel and Sub-Assembly Removal (Continued)

"Board 1" Removal

- A. Remove control panel.
- B. Remove all knobs associated with Board 1. "X" and "Y" waveform selector knobs are held on with set screws.
- C. Unplug the cable harness.
- D. Remove 12 spring retainer clips.
- E. Lift P/C Board off Guide Pins.

"Board 2" Removal

- A. Remove control panel.
- B. Remove all knobs associated with Board 2.
- C. Unplug the cable harness and the speaker wires.
- D. Remove 10 spring retainer clips.
- E. Lift P/C Board off Guide Pins.

"Board 3" Removal

- A. Remove lower tray cover.
- B. Remove four screws holding Board 3 in place.
- C. Tilt Board 3 backward, do not overstress the wiring harness.



SECTION VI: Panel and Sub-Assembly Removal (Continued)

"Keyboard" Removal

- A. Remove lower tray cover.
- B. Remove lower tray assembly.
- C. Remove six keyboard mounting screws.
- D. Unsolder three wires, one at the left end, two at the right end of the keyboard.

"Speaker" Removal

- A. Remove control panel.
- B. Unplug speaker wires from Board 2.
- C. Remove speaker mounting hardware.
- D. Lift speaker off studs.

SECTION VII: Adjustment Procedures

NOTE: The tuning and other functions are heavily reliant on accurate power supply voltages. Follow this procedure in sequence, do not change the order of adjustments.

TO ADJUST	FOLLOW THIS PROCEDURE
+15 Volt Supply	<ol style="list-style-type: none"> <li>1. Connect a Digital Voltmeter (with 0.1% accuracy) low side to ground high side to pin A4 on Board 1.</li> <li>2. Adjust the <u>+V</u> trimpot (R38) for +15.00 volts.</li> </ol>
-15 Volt Supply	<ol style="list-style-type: none"> <li>1. Connect a Digital Voltmeter (with 0.1% accuracy), low side to ground high side to pin A5 on Board 1.</li> <li>2. Adjust the <u>-V</u> trimpot (R43) for -15.00 volts.</li> </ol>
OSCILLATOR "A" Symmetry	<ol style="list-style-type: none"> <li>1. Connect a VTVM, with a center zero scale, to pin 2 of IC15.</li> <li>2. Set OSCILLATOR "A" for low frequency (approximately 100 Hz).</li> <li>3. Adjust <u>S-A</u> trimpot (R74) for zero volts DC.</li> </ol>

SECTION VII: Adjustment Procedures (Continued)

TO ADJUST	FOLLOW THIS PROCEDURE
<p>OSCILLATOR "B" Symmetry</p>	<ol style="list-style-type: none"> <li>1. Connect a VTVM, with a center zero scale, to pin 2 of IC21.</li> <li>2. Set OSCILLATOR "B" for low frequency (approximately 100 Hz)</li> <li>3. Adjust S-B trimpot (R117) for zero volts DC.</li> </ol>
<p>KEYBOARD CIRCUIT</p>	<ol style="list-style-type: none"> <li>1. Connect a Digital Voltmeter low side to "keyboard buss" (pin D1) high side to "KB1" (Pin D5).</li> <li>2. Alternately depress low and high "C".</li> <li>3. Adjust FET Balance trimpot (R23) so that the voltage level is the same for low and high "C". Disconnect voltmeter.</li> <li>4. Set OSCILLATOR "B" PITCH control to CONCERT (fully CCW in click).</li> <li>5. Set OCTAVE switches to 0.</li> <li>6. Set WAVEFORM switches to sawtooth.</li> </ol>

SECTION VII: Adjustment Procedures (Continued)

TO ADJUST	FOLLOW THIS PROCEDURE
	<ol style="list-style-type: none"><li data-bbox="880 548 1787 766">7. Turn PITCH CONTROL INPUTS (X/Y, Contour, and OSC A) off (fully CCW in click).</li><li data-bbox="880 851 1743 984">8. Set SCALE control to DIATONIC (fully CW).</li><li data-bbox="880 1068 1720 1365">9. Turn OSCILLATOR "A" and "B" OUTPUT MIXER controls on so that both oscillators can be heard.</li><li data-bbox="880 1450 1798 1583">10. Set KEYBOARD switch to the HIGH NOTE position (right).</li><li data-bbox="880 1668 1798 1801">11. Connect an oscilloscope to the MONITOR jack to observe output.</li><li data-bbox="880 1886 1665 1931">12. Depress and hold high "C".</li><li data-bbox="880 2016 1798 2313">13. Tune OSCILLATOR "A" using the PITCH control, to the same frequency that OSCILLATOR "B" is producing (zero beat).</li><li data-bbox="880 2398 1754 2531">14. Switch the KEYBOARD switch to LOW NOTE (left.)</li></ol>

SECTION VII: Adjustment Procedures (Continued)

TO ADJUST	FOLLOW THIS PROCEDURE
	<p>15. Still holding Hi "C" depressed, adjust <u>KB</u> trimpot (R8 on Board 2) so that OSCILLATOR "A" and "B" zero beat.</p> <p>16. Switch back to HIGH NOTE and check that OSCILLATORS "A" and "B" are still zero beating. If not, repeat steps 10 thru 15.</p>
PITCH BENDER	<p>1. Connect a digital voltmeter low side to ground, high side to the Pitch Bender output. This output is available in the lower tray at pin 5 of Board 3 or behind the control panel on pin B6 or B8.</p> <p>2. If the output voltage is less than 50 MV, no adjustment is required. If the output voltage is in excess of 50 MV, proceed to step 3.</p> <p>3. Loosen the set screw in the Pitch Bender Wheel.</p>

SECTION VII: Adjustment Procedures (Continued)

TO ADJUST	FOLLOW THIS PROCEDURE
	<ol style="list-style-type: none"> <li>4. Rotate the control shaft until the output voltage is zero.</li> <li>5. Tighten the set screw and check to see that the output is still less than 50 MV when the wheel is centered.</li> </ol>
<p>OSCILLATOR "B" Tuning</p>	<ol style="list-style-type: none"> <li>1. Turn KEYBOARD switch OFF (center).</li> <li>2. Turn OSCILLATOR "A" OUTPUT MIXER control off. (Listen to "B" only).</li> <li>3. Depress and hold middle "C". Adjust <u>C-B</u> (R105) for 261.6 Hz. (Use a frequency counter or zero beat with a "C" tuning fork).</li> <li>4. Turn OSCILLATOR "A" OUTPUT MIXER control on. Adjust level so that both oscillators can be heard.</li> <li>5. With Middle "C" still depressed, tune OSCILLATOR "A" via the PITCH control to zero beat with OSCILLATOR "B". (OSCILLATOR "A" now tuned to 261.6 Hz)</li> </ol>

SECTION VII: Adjustment Procedures (Continued)

TO ADJUST	FOLLOW THIS PROCEDURE
	<p>6. Depress and hold high "C". (OSCILLATOR "B" will increase in frequency by two octaves, OSCILLATOR "A" will remain at middle "C").</p> <p>7. Adjust <u>HI-B</u> (R104) for zero beats two octaves above middle "C". The frequency of high "C" is 1046.4 Hz. (The beat note can easily be seen on oscilloscope.)</p> <p>8. Depress and hold low "C".</p> <p>9. Adjust <u>LO-B</u> (R108) for zero beats two octaves below Middle "C". (65.4 Hz)</p> <p>10. These three tuning adjustments are interactive. It may be necessary to repeat steps 5 thru 9 until no further improvement is attainable.</p>
Chip Temperature	<p>1. If unable to obtain proper scale and/or pitch with the above procedure, it may be necessary to make</p>

SECTION VII: Adjustment Procedures (Continued)

TO ADJUST	FOLLOW THIS PROCEDURE
	<p>a very slight change of the <u>chip temperature</u> trimpot (R135). This acts as a coarse scale adjustment and normally requires change only when the heated chip (IC24) is replaced. Changing the setting of this will affect both oscillators "A" and "B" and make it necessary to re-tune both.</p>
<p>OSCILLATOR "A" Tuning</p>	<ol style="list-style-type: none"> <li>1. Now that OSCILLATOR "B" is tuned, it will be used as a reference to simplify the tuning of OSCILLATOR "A".</li> <li>2. Adjust OUTPUT MIXER controls so that both oscillators can be heard.</li> <li>3. Set SCALE control to DIATONIC (fully CW).</li> <li>4. Set KEYBOARD switch to HIGH NOTE.</li> </ol>



SECTION VII: Adjustment Procedures (Continued)

TO ADJUST	FOLLOW THIS PROCEDURE
	<ol style="list-style-type: none"> <li>5. Set OSCILLATOR "A" and "B" OCTAVE switches to 0.</li> <li>6. Set OSCILLATOR "B" PITCH Control to CONCERT (fully CCW in click).</li> <li>7. Set OSCILLATOR "A" PITCH Control to 0.</li> <li>8. Depress Middle "C" and adjust <u>C-A</u> trimpot (R62) for zero beat with OSCILLATOR "B" (261.6 H<sub>z</sub>).</li> <li>9. Depress High "C" and adjust <u>HI-A</u> trimpot (R61) for zero beats (1046.4 H<sub>z</sub>).</li> <li>10. Depress low "C" and adjust <u>LO-A</u> trimpot (R65) for zero beats (65.4 H<sub>z</sub>).</li> <li>11. These three tuning adjustments are interactive. It may be necessary to repeat steps 8 thru 10 until no further improvement is attainable.</li> </ol>

SECTION VII: Adjustment Procedures (Continued)

TO ADJUST	FOLLOW THIS PROCEDURE
<p>OSCILLATOR "X" Symmetry</p>	<ol style="list-style-type: none"> <li>1. Use OSCILLATOR "X" triangle at minimum rate to modulate OSCILLATOR "A".</li> <li>2. While listening to OSCILLATOR "A", adjust <u>X-LO</u> trimpot (R13) so that the pitch rise and fall times are equal.</li> </ol>
<p>OSCILLATOR "Y" Symmetry</p>	<ol style="list-style-type: none"> <li>1. Use OSCILLATOR "Y" triangle at minimum rate to modulate OSCILLATOR "A".</li> <li>2. While listening to OSCILLATOR "A" adjust <u>Y-LO</u> trimpot (R28) so that the pitch rise and fall times are equal.</li> </ol>
<p>RING MODULATOR</p>	<ol style="list-style-type: none"> <li>1. Turn on RING MODULATOR at the OUTPUT MIXER (all other signals off)</li> <li>2. Set the SIGNAL INPUT switch to TONE OSC "B".</li> </ol>

SECTION VII: Adjustment Procedures (Continued)

TO ADJUST	FOLLOW THIS PROCEDURE
	<ol style="list-style-type: none"> <li>3. Set the MODULATING INPUT switch to mid-position (between positions) so that no modulating signal is present.</li> <li>4. Adjust <u>Mod Balance</u> trimpot (R43) for minimum output.</li> <li>5. Set the MODULATING INPUT switch to tone OSC A.</li> <li>6. Set the SIGNAL INPUT switch to EXT INPUT (Do not apply an external signal)</li> <li>7. Adjust <u>Sig Bal</u> trimpot (R39) for minimum output.</li> <li>8. Turn off RING MODULATOR at the OUTPUT MIXER.</li> </ol>
NOISE	<ol style="list-style-type: none"> <li>1. Connect a DB meter to the PHONES jack (Note: This is a stereo jack, if a monaural plug is used, plug it in half way only to prevent shorting.)</li> </ol>

SECTION VII: Adjustment Procedures (Continued)

TO ADJUST	FOLLOW THIS PROCEDURE
	<ol style="list-style-type: none"> <li>2. Set the ARTICULATOR switch to BYPASS.</li> <li>3. Set filter CUTOFF FREQUENCY control to 10 (Up).</li> <li>4. Set filter RESONANCE control to 0 (down).</li> <li>5. Turn on NOISE at the SOURCE MIXER (fully CW) all other signals off.</li> <li>6. Set MASTER VOLUME control to max.</li> <li>7. Set NOISE SOURCE switch to WHITE.</li> <li>8. Adjust <u>Noise Level</u> trimpot (R55) for +10 DB.</li> </ol>
VCA Balance	<ol style="list-style-type: none"> <li>1. Turn off all OUTPUT and SOURCE MIXER controls.</li> <li>2. Connect a jumper from pin C15 to Pin C3.</li> <li>3. Set Master VOLUME control to max.</li> </ol>

SECTION VII: Adjustment Procedures (Continued)

TO ADJUST	FOLLOW THIS PROCEDURE
	<ol style="list-style-type: none"> <li>4. Set OSCILLATOR "A" waveform switch to square wave.</li> <li>5. Adjust <u>VCA Bal</u> trimpot (R138) for minimum level at speaker.</li> <li>6. Remove jumper.</li> </ol>
ARTICULATOR BALANCE	<ol style="list-style-type: none"> <li>1. Turn off all OUTPUT and SOURCE MIXER controls.</li> <li>2. Set ARTICULATOR switch to the left position.</li> <li>3. Turn GEN X trigger switch on (below contour generator).</li> <li>4. Set WAVEFORM GENERATOR X for full speed (RATE and MASTER RATE controls at maximum).</li> <li>5. Set ATTACK and DECAY at 0 (min.)</li> <li>6. Set MASTER VOLUME control to 10 (max).</li> <li>7. Adjust <u>Artic</u> trimpot (R74) for minimum output at speaker.</li> </ol>

SECTION VII: Adjustment Procedures (Continued)

TO ADJUST	FOLLOW THIS PROCEDURE
<p>FILTER</p>	<ol style="list-style-type: none"> <li>1. Turn all signal sources off.</li> <li>2. Set ARTICULATOR to BYPASS.</li> <li>3. Set CUTOFF FREQUENCY control to 5.</li> <li>4. Set RESONANCE control to 10.</li> <li>5. Turn KEYBOARD CONTROL INPUT to filter on.</li> <li>6. Depress Middle "C".</li> <li>7. If filter is not regenerating (oscillating), adjust <u>Regen.</u> trimpot (R171) clockwise until regeneration occurs.</li> <li>8. Alternately, depress middle and high "C" while adjusting <u>Scale</u> trimpot (R179) for a two octave change (use frequency counter if necessary.).</li> <li>9. After <u>Scale</u> is set, turn off KEYBOARD CONTROL INPUT.</li> <li>10. Check that CUTOFF FREQUENCY control is still at 5.</li> </ol>

SECTION VII: Adjustment Procedures (Continued)

TO ADJUST	FOLLOW THIS PROCEDURE
	11. Adjust <u>Pitch</u> trimpot (R160) so the filter is producing $1000 \pm 20$ Hz.

- 4
- 5
- 6
- 7
- 8
- 9

- 12
- 14
- 15

A

-V  
R48

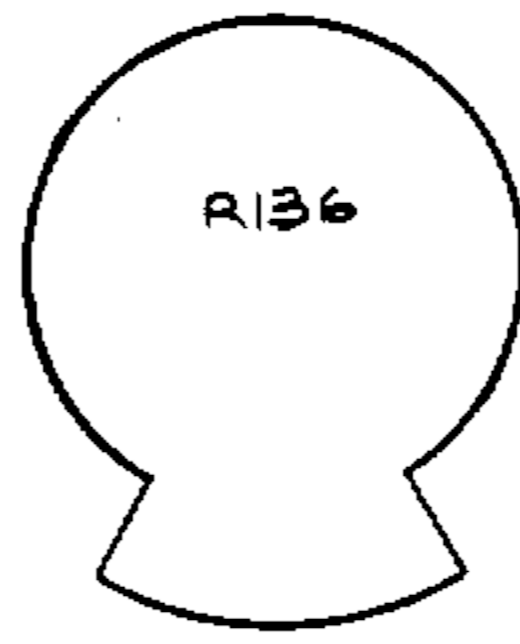

+V  
R38

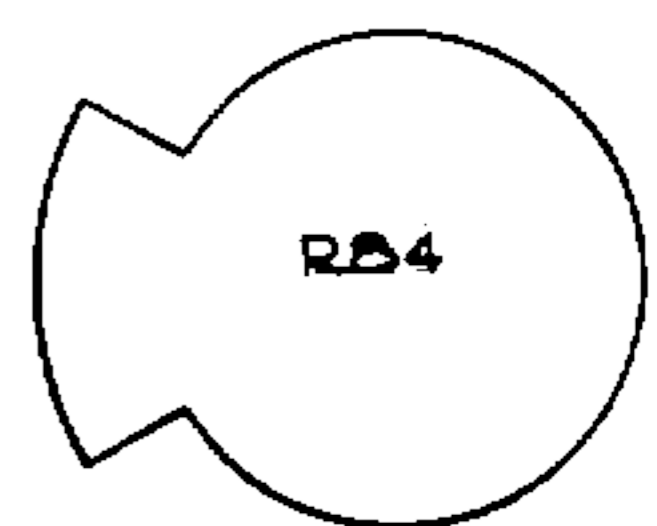
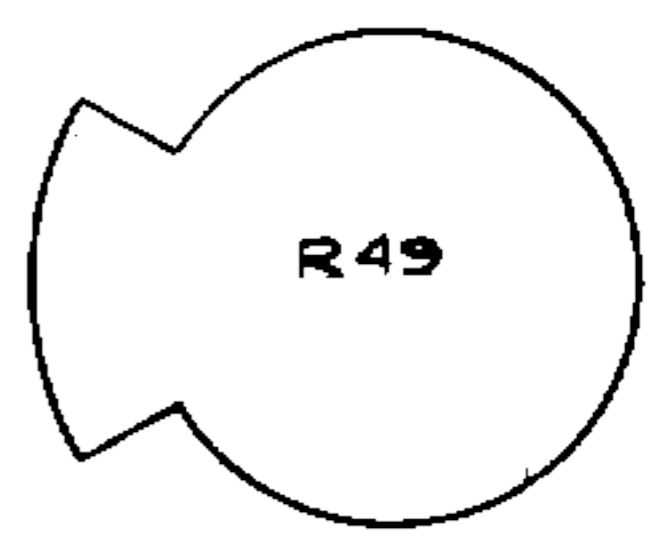
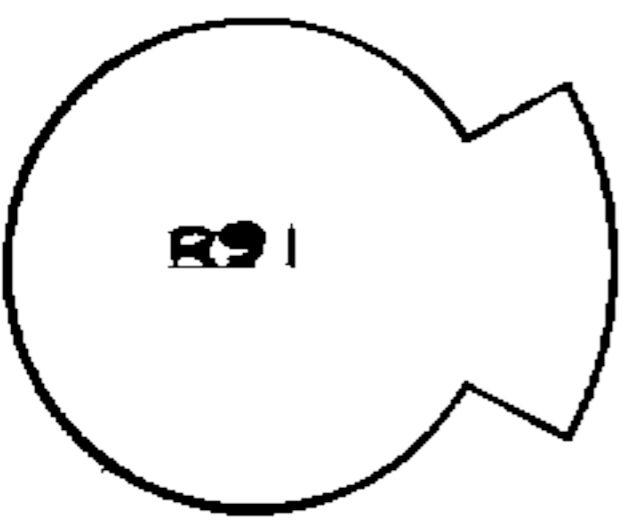

CT (CHIP TEMP)  
R35

S-B  
R117  
LO-B  
R108

S-A  
R74  
LO-A  
R65

- 5
- 6
- 7
- 8
- 9
- 10
- 11

- 13
- 14
- 15

B

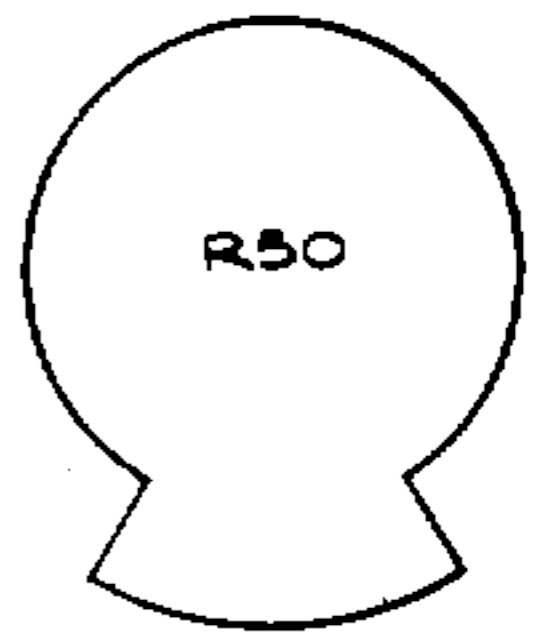
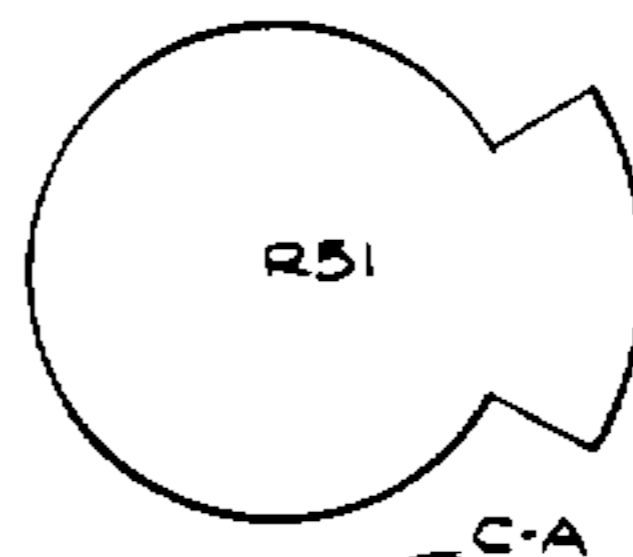
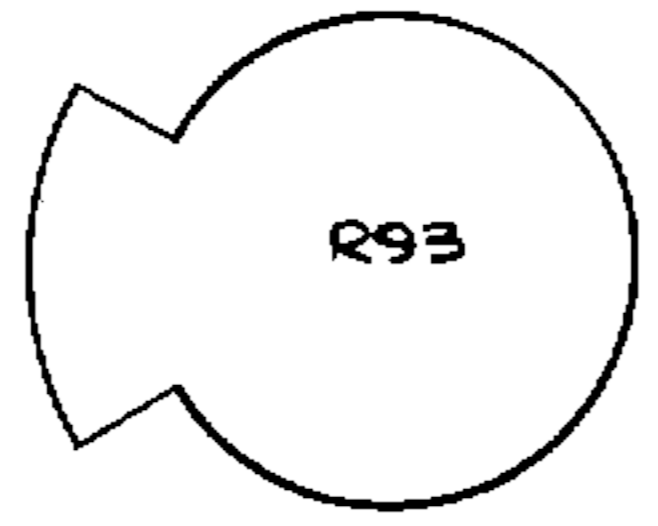
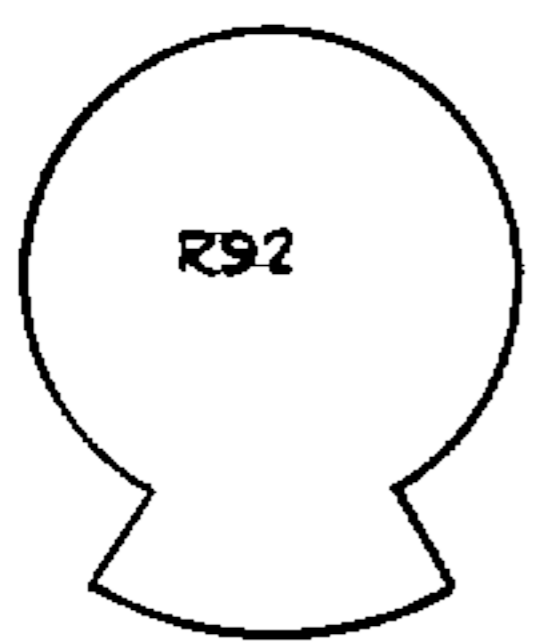

C-B  
R105

C-A  
R62

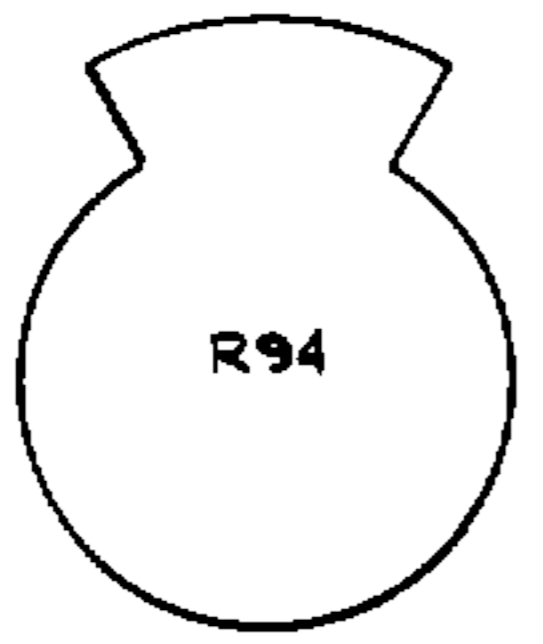

HI-B  
R104

HI-A  
R61



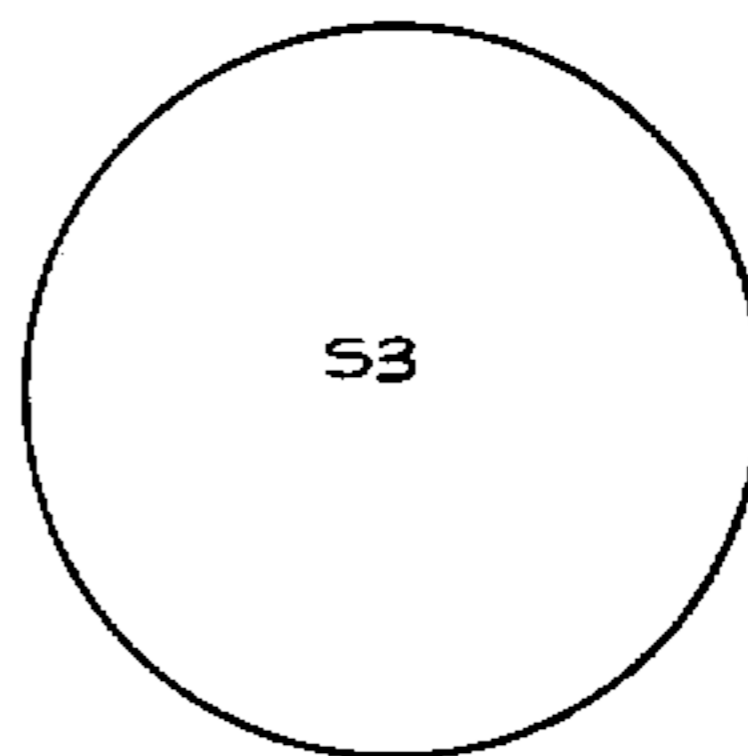
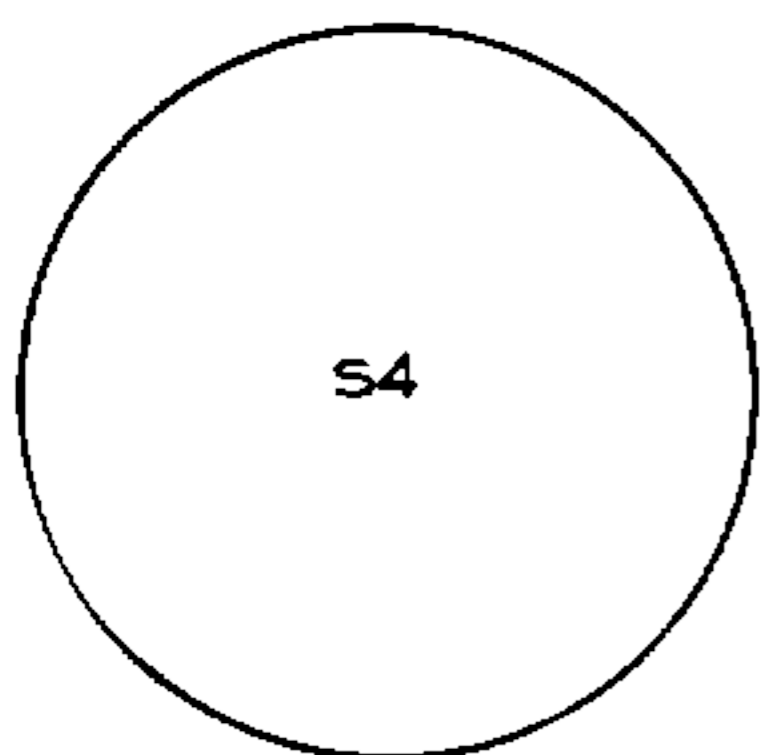
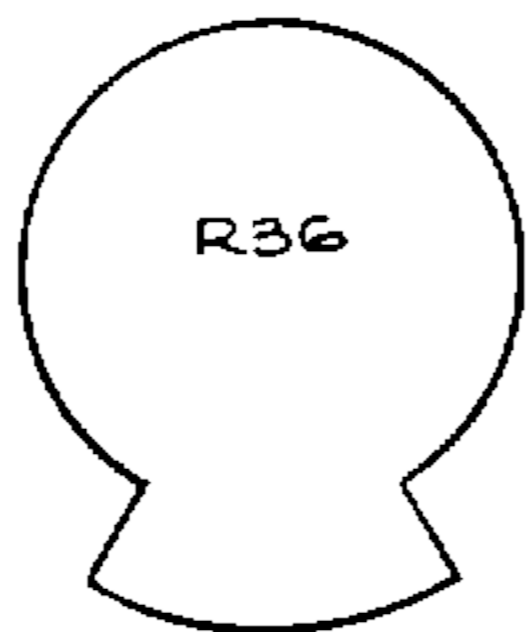



Y-LOW  
  
 R28

X-LOW  
  
 R13

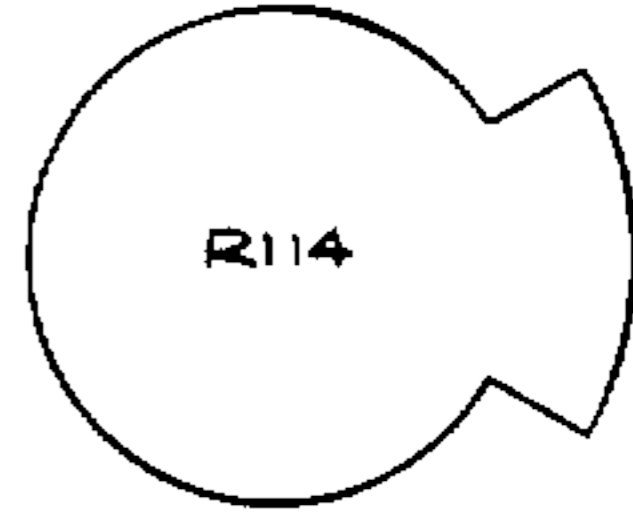
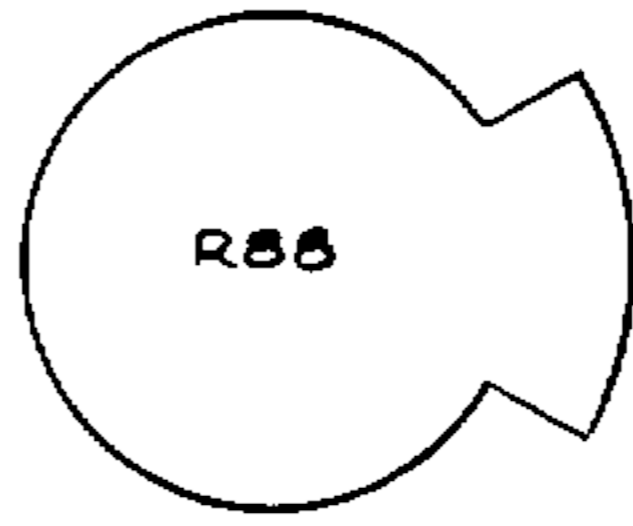
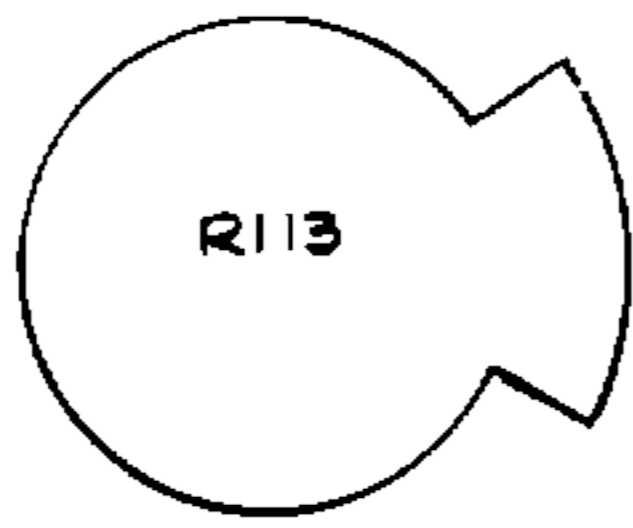
ITEM	PART NUMBER	DESCRIPTION	MATERIAL
UNLESS OTHERWISE SPECIFIED DIMENSIONS ARE IN INCHES TOLERANCE FRACTIONS: 1/64 INCHES 3 PLACE DECIMALS: .008 2 PLACE DECIMALS: .01 125 FRESH ON ALL SURFACES		DRAWN BY JMP 10/73 CHECK R JF 10/73	 WILLIAMSVILLE, NEW YORK
DRILLED HOLE TOL .040 - .025 DIA .0015 .125 - .250 DIA .002 .250 - .500 DIA .003 .500 - 750 DIA .004		GRP ENGR. REVIEW QC. SUPERVISOR	ADJUSTMENT LOCATI SONIC SIX BOARD
NEXT ASSY		MODEL NO.	SIZE CODE IDENT 93-119
APPLICATION		SCALE	WT. SHEET



VCA BAL  
  
R128

IC28

REGEN  
  
R171

ARTIC  
  
R74

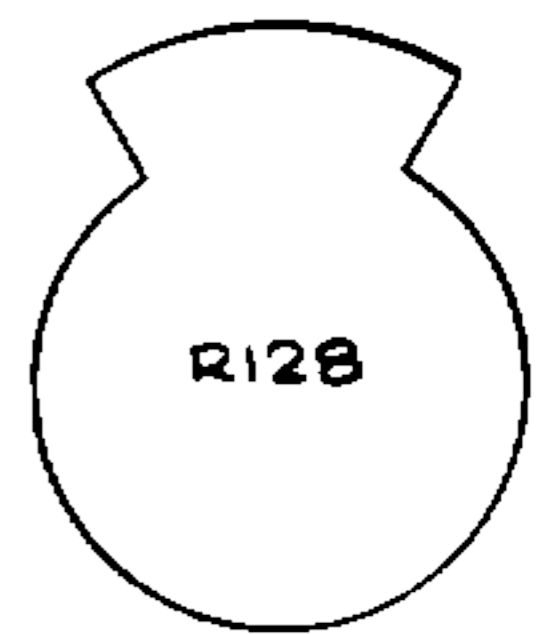

SCALE  
  
R179

PITCH  
  
R160

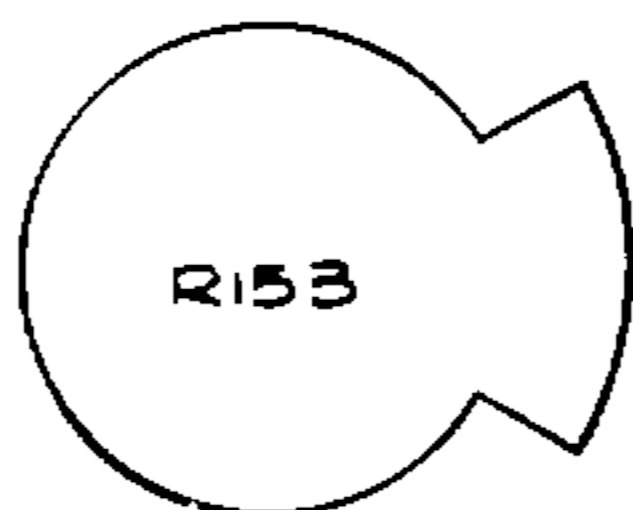
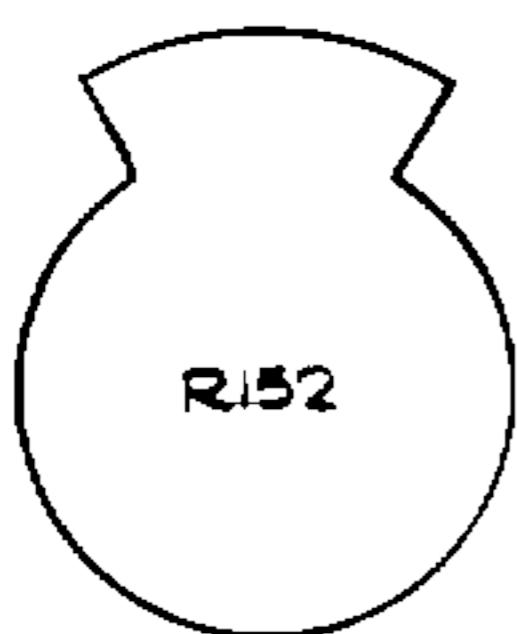

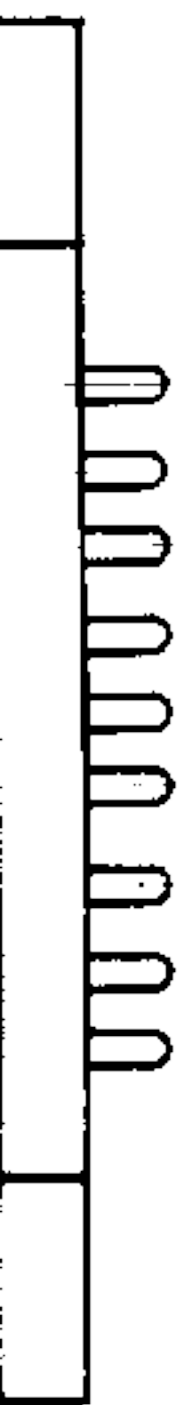

KB  
RB

FET BAL  
R23

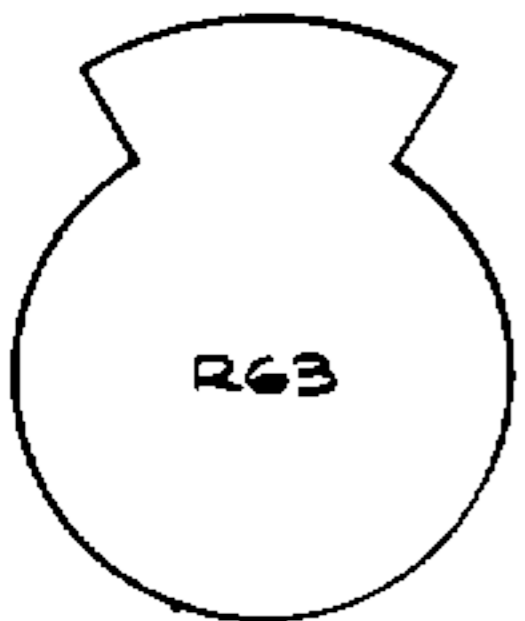

SIG. BAL  
R39

MOD BAL  
R43



NOISE  
R55

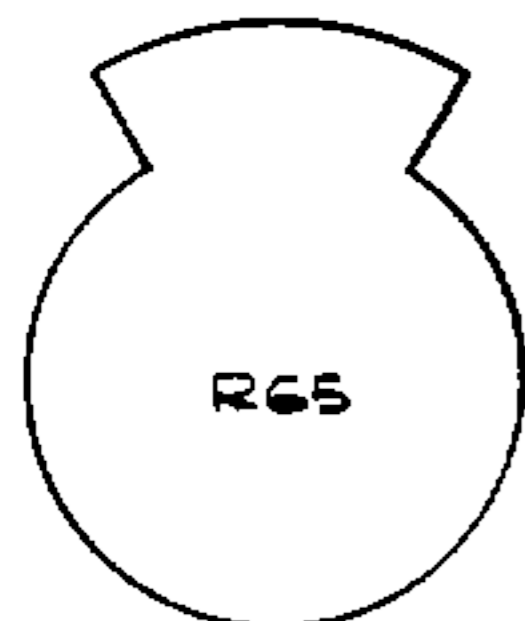

- 1
- 2
- 3
- 4
- 5
- 6
- 7
- 8
- 9
- 10
- 11
- 12
- 13
- 14
- 15
- C

- 1
- 2
- 3
- 4
- 5

- 10
- 11
- 12
- 13
- 14
- 15
- D

ITEM	PART NUMBER	DESCRIPTION	MATERIAL
UNLESS OTHERWISE SPECIFIED DIMENSIONS ARE IN INCHES TOLERANCE FRACTIONS - 1/64		DRAWN BY JMP 10/73	meog MUSIC INC WILLIAMSVILLE, NEW YORK
CHECK R J F 10/73		ADJUSTMENT LOCATIONS SONIC SIX BOARD 2	
GRP ENGR.		SIZE	CODE IDENT
REVIEW QC.		93-120	
SUPERVISOR		SCALE	WT.
NEXT ASSY		MODEL NO.	SHEET OF
APPLICATION			

## SECTION VIII: Keyboard Maintenance

Occasionally, it will become necessary to clean and adjust the keyboard. The contacts, although gold plated, may become dirty, contaminated, or corroded. When contacts become poor, noises and erratic sounds may be generated while playing the instrument.

To gain access to the keyboard, remove the lower tray and lower tray cover. An opening in the base plate will allow cleaning and adjusting to be performed without dismounting the keyboard. Avoid touching the "Buss Bar" and the "Contact Wires" with the fingers since hand oils and perspiration will cause corrosion. Under normal conditions, any dirt can be removed by spraying the buss bar and contacts with a light coating of a high grade contact cleaner. At the factory, we use and recommend "Cramolin" (R). If this is not available, TV tuner spray may be used. Do NOT under any circumstances, use abrasives or abrasive tools, since this will destroy the gold plating. If spraying does not cure the problem, try wiping the buss bar with a cotton swab in the area of the problem key or keys.

Sometimes, it is necessary to adjust the contact wires for more or less tension. If the contacts are positioned too close to the buss bar, a condition known as "contact bounce" will occur. This results in double triggering. If the contacts

SECTION VIII: Keyboard Maintenance

are positioned too far from the buss bar, a poor or undependable contact will be made. This has two disadvantages, one being the generation of erratic pitch changes; the other is excessive key travel before contact occurs.

To clean the keys, use a soft cloth moistened with a mild soap solution. Never allow cleaning agents to run down between the keys. Avoid harsh solvents, since the keys are made of plastic and may be dissolved. Scratches may be removed with a plastic or automotive polishing compound. Waxing the keys is not recommended.

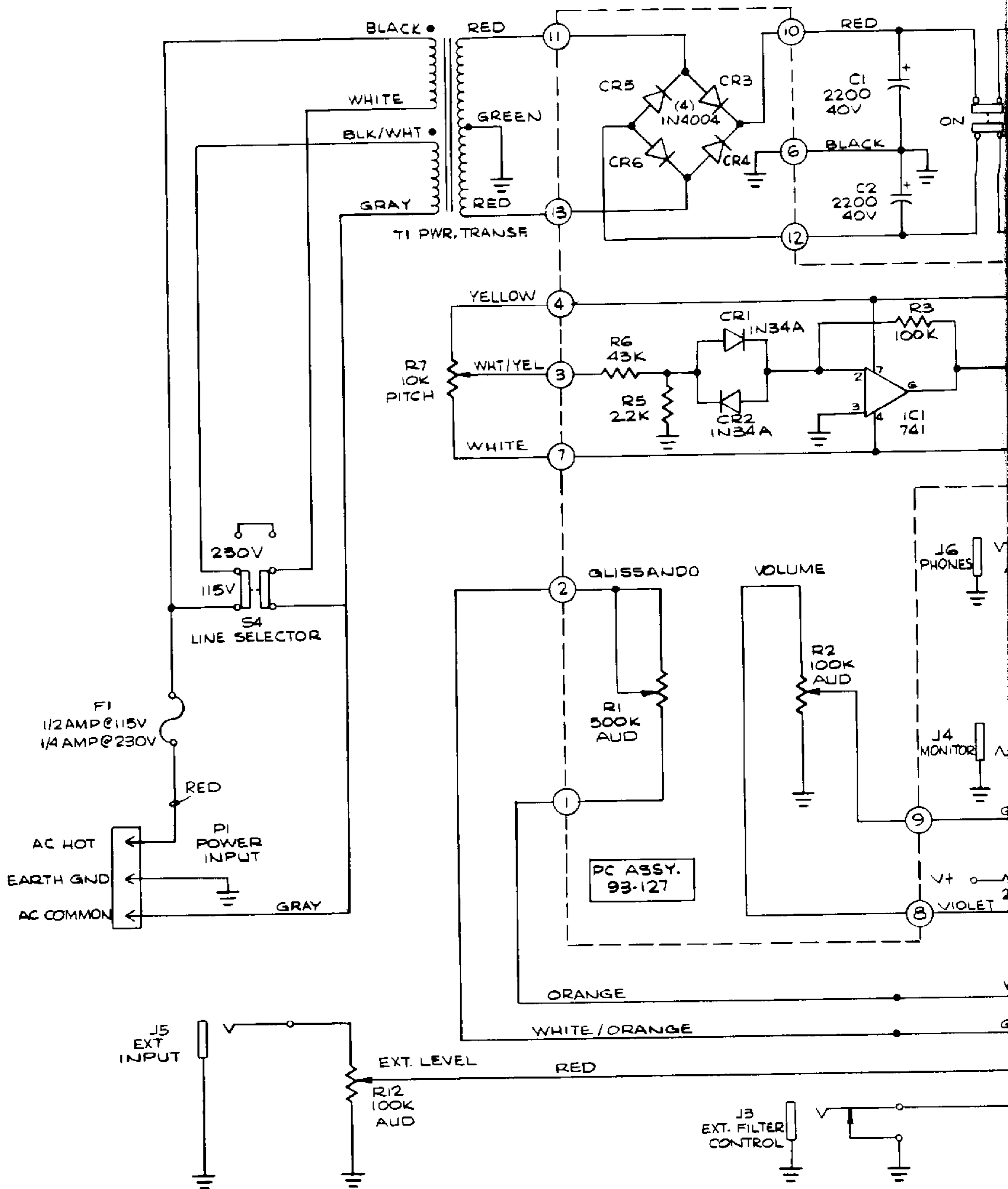

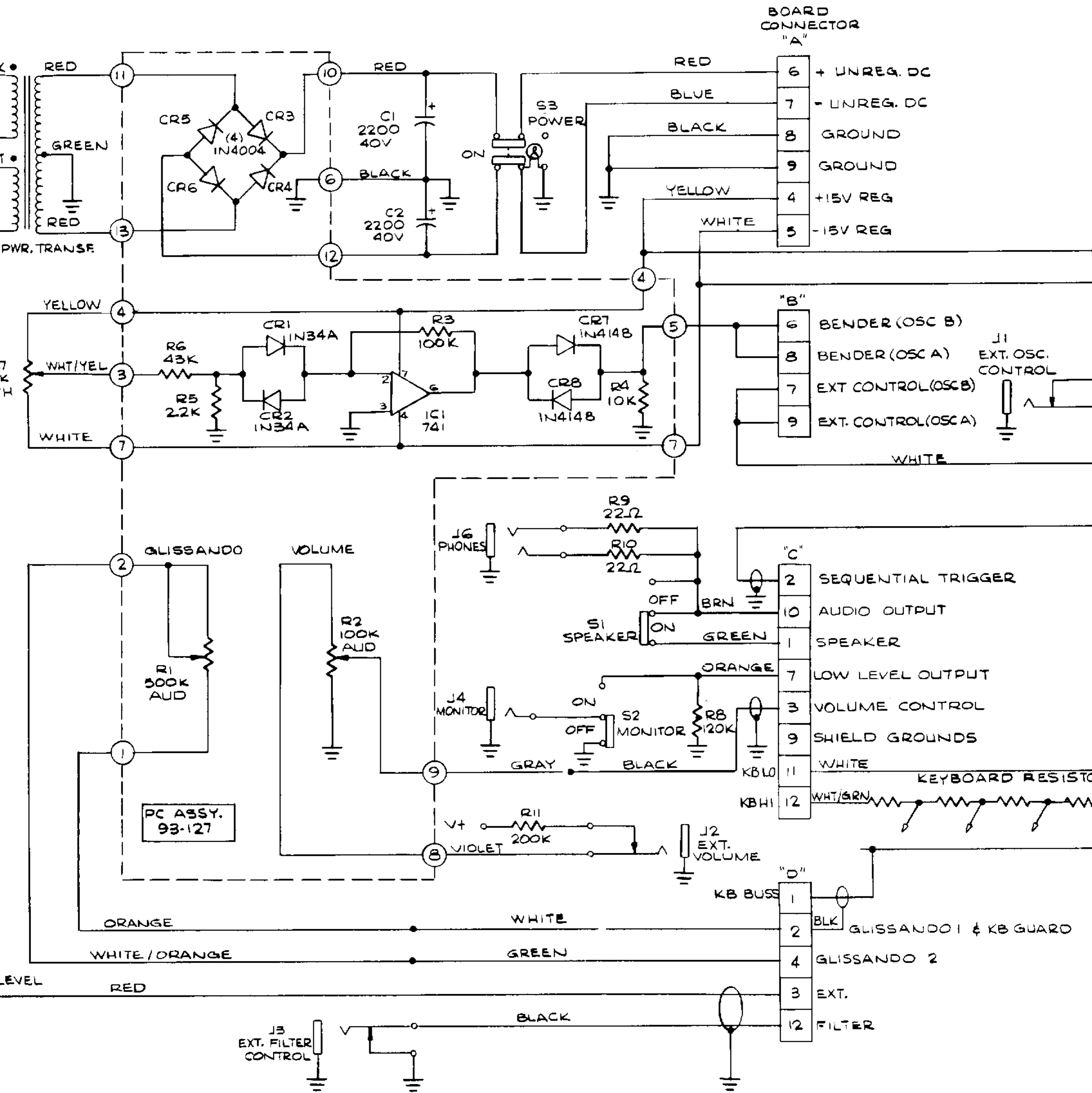

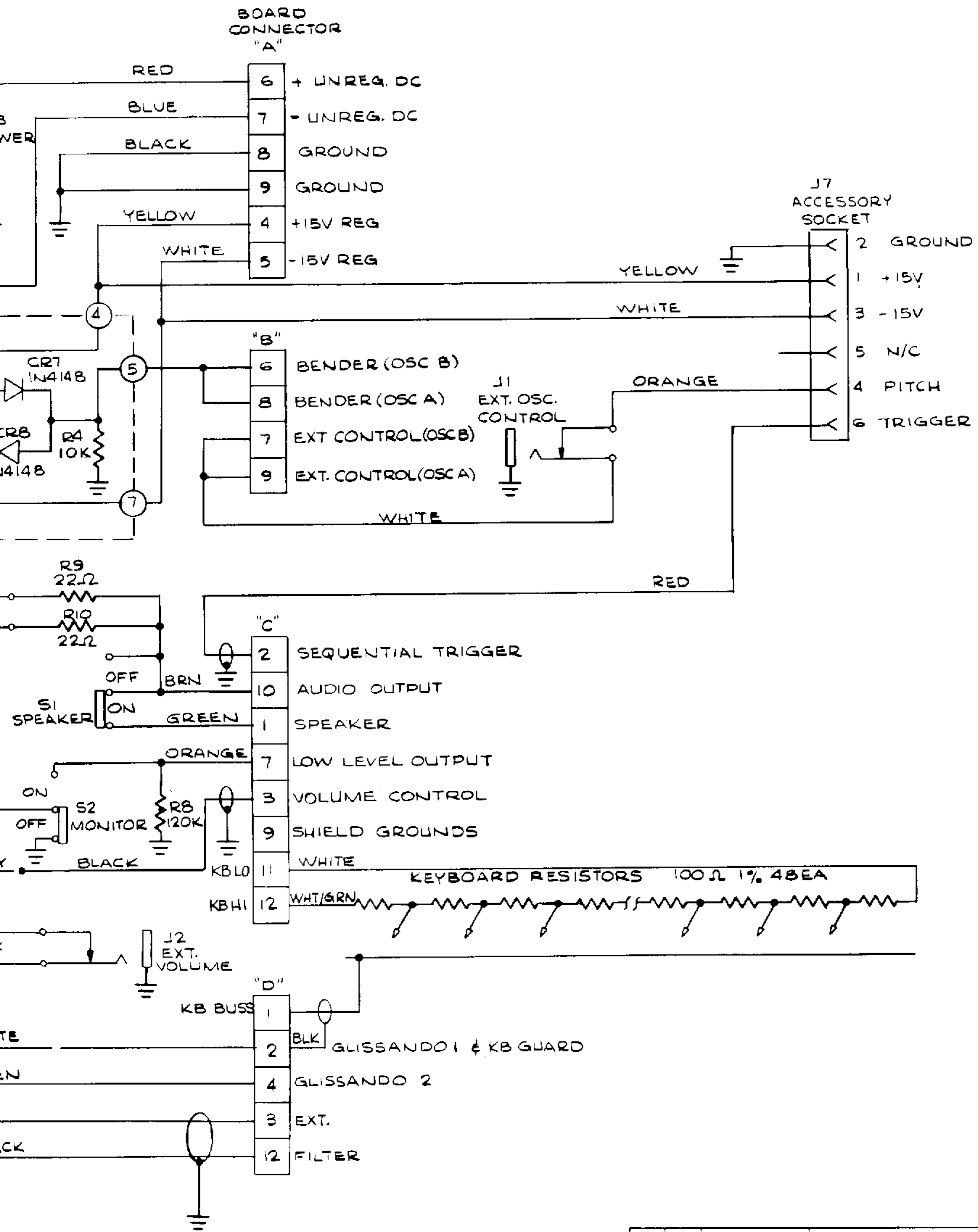

ITEM	PART NUMBER	DESCRIPTION	MATERIAL
DRAWN BY JMP 10/73		WILLIAMSVILLE, NEW YORK <b>SONIC SIX</b> <b>SCHEMATIC (MAIN FRAME)</b>	
CHECK RJP 10/73			
GRP ENGR.		SIZE	CODE IDENT
REVIEW QC.		08-010	
SUPERVISOR			
NEXT ASSY		MODEL NO	
APPLICATION		SCALE	WT SHEET OF

UNLESS OTHERWISE SPECIFIED DIMENSIONS ARE IN INCHES  
TOLERANCES FRACTIONS 1/64  
ANGLES 1:2  
3 PLACE DECIMALS - .005  
2 PLACE DECIMALS - .01  
125 FINISH ON ALL SURFACES

DRILLED HOLE TOL  
040 - .125 DIA ± .001  
126 - .228 DIA ± .001  
228 - .500 DIA ± .001  
500 - .750 DIA ± .001





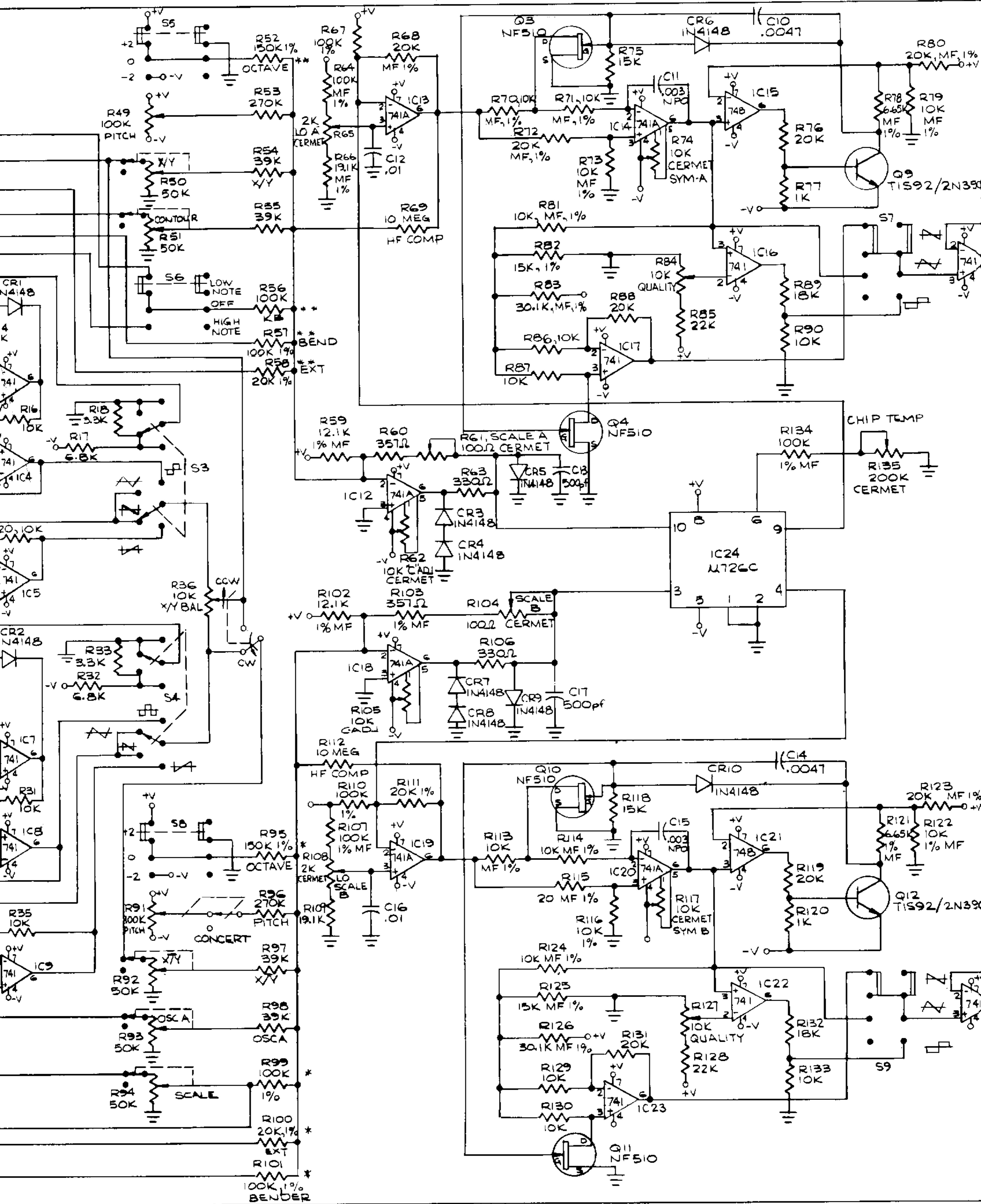





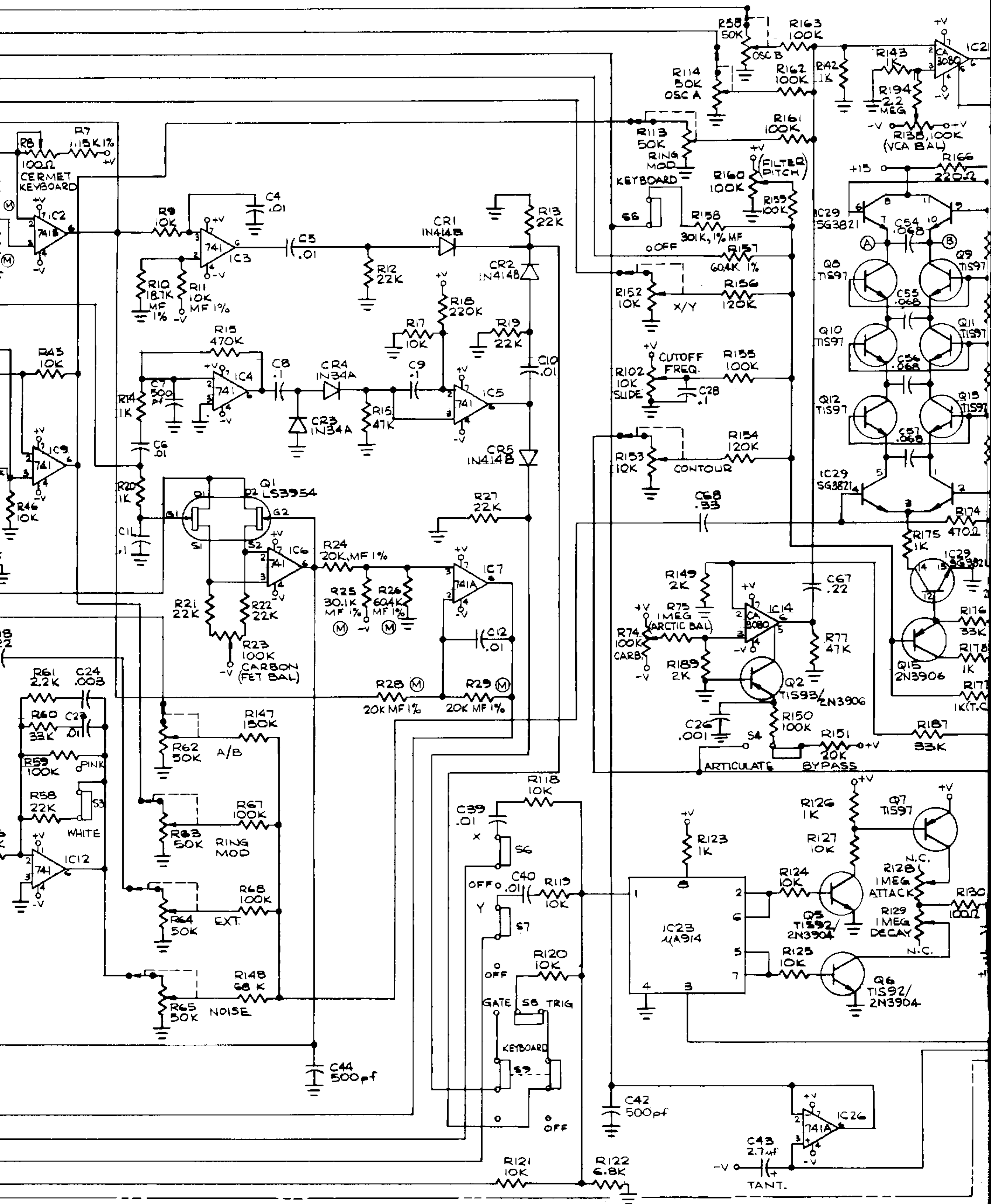

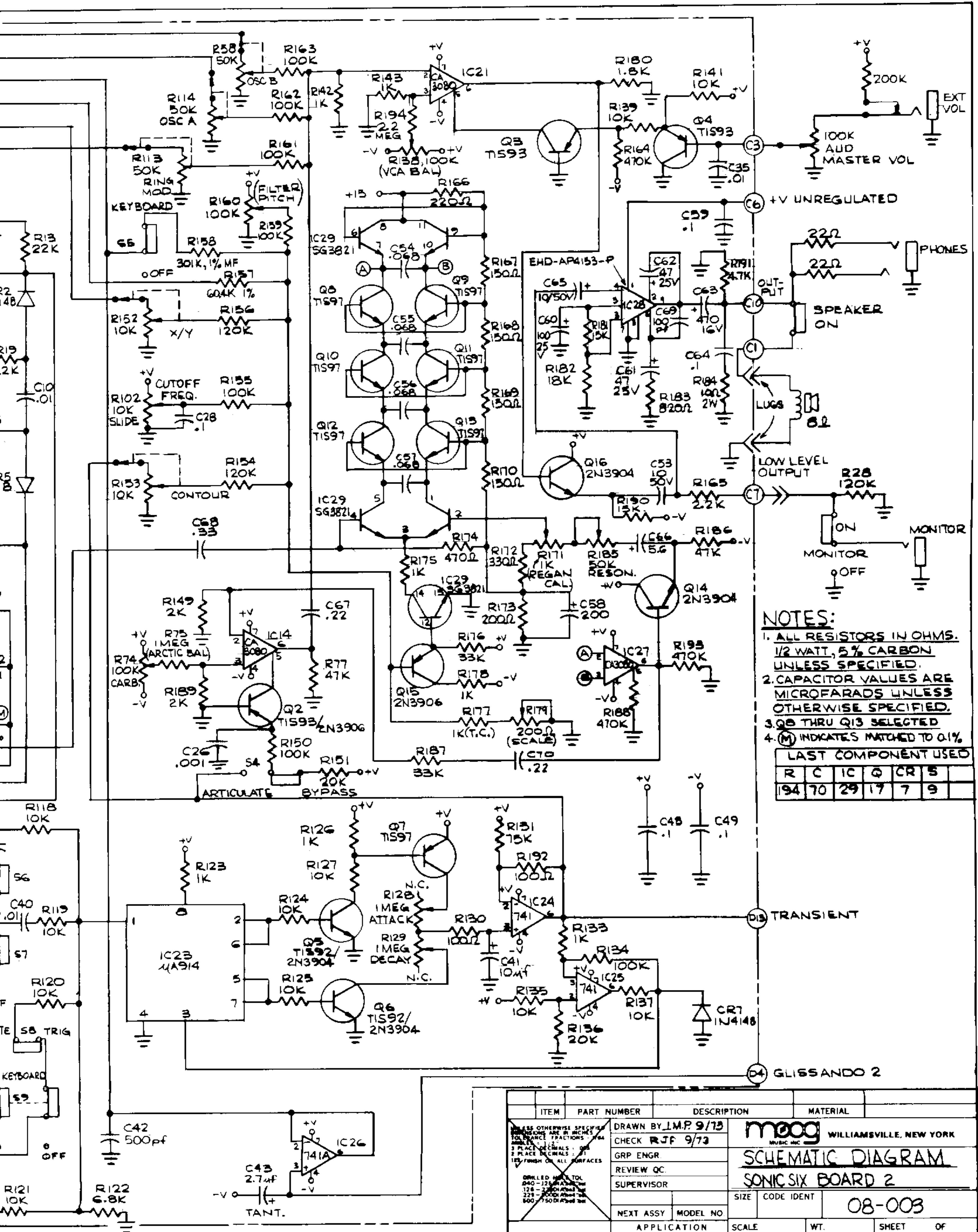

**NOTES:**

1. ALL RESISTORS IN OHMS. 1/2 WATT, 5% CARBON UNLESS SPECIFIED.
2. CAPACITOR VALUES ARE MICROFARADS UNLESS OTHERWISE SPECIFIED.
3. Q8 THRU Q13 SELECTED
4. (M) INDICATES MATCHED TO 0.1%

LAST COMPONENT USED				
R	C	IC	Q	CR
194	70	29	17	7 9

ITEM	PART NUMBER	DESCRIPTION	MATERIAL
<small>UNLESS OTHERWISE SPECIFIED TOLERANCES ARE IN INCHES            DIMENSIONS ARE IN DECIMALS            3 PLACE DECIMALS - .01            2 PLACE DECIMALS - .1            1 PLACE DECIMALS - 1            125° FINISH ON ALL SURFACES</small>			
DRAWN BY: J.M.P. 9/75		moog WILLIAMSVILLE, NEW YORK	
CHECK: R.J.F. 9/75		SCHEMATIC DIAGRAM	
GRP ENGR		SONICSIX BOARD 2	
REVIEW QC		SIZE	CODE IDENT
SUPERVISOR		08-003	
NEXT ASSY	MODEL NO	SCALE	WT.
APPLICATION			SHEET OF

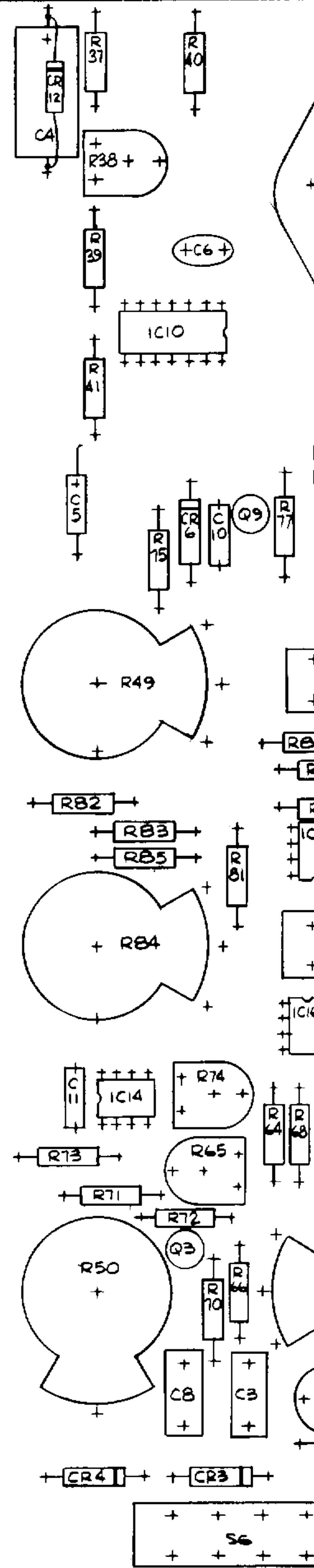
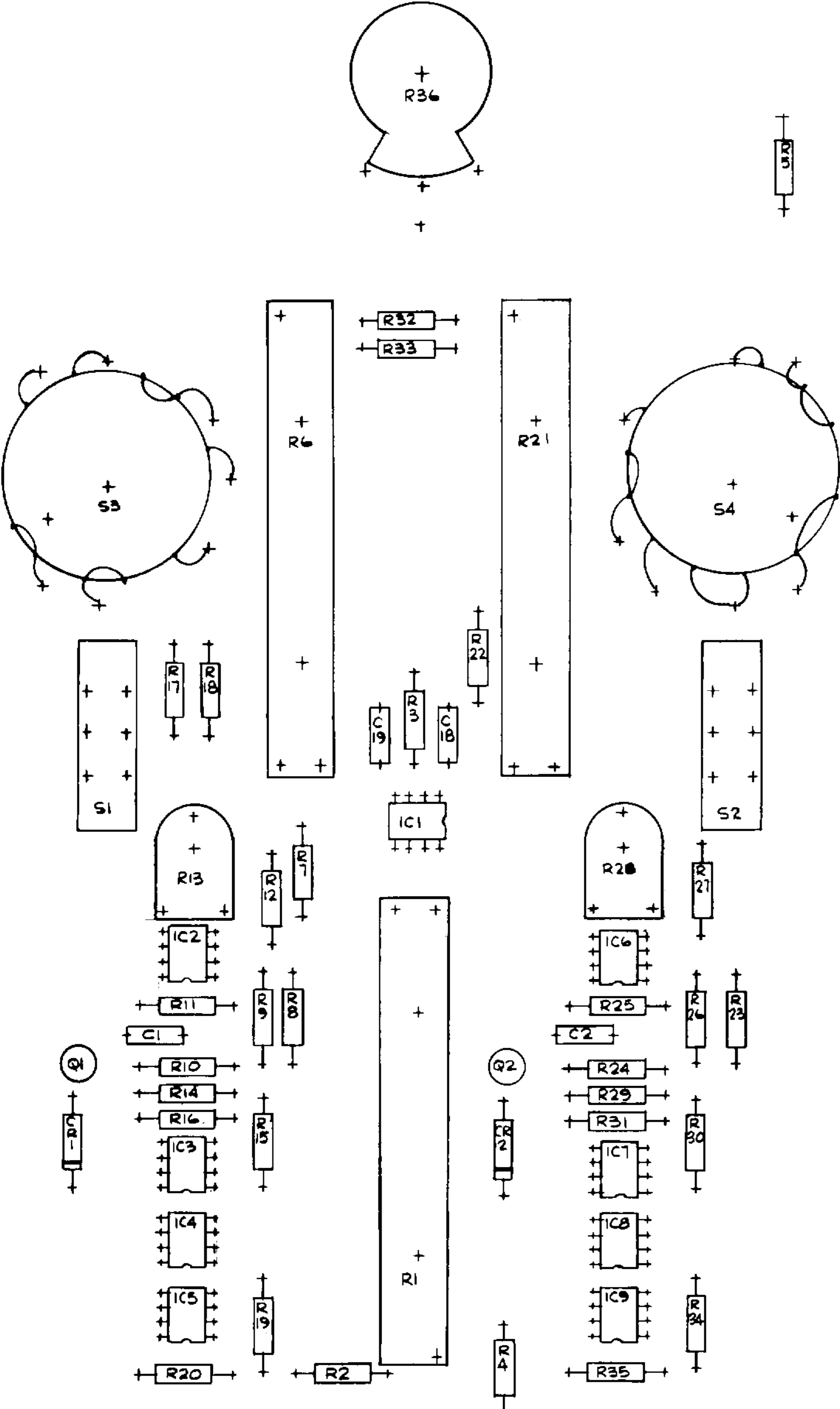

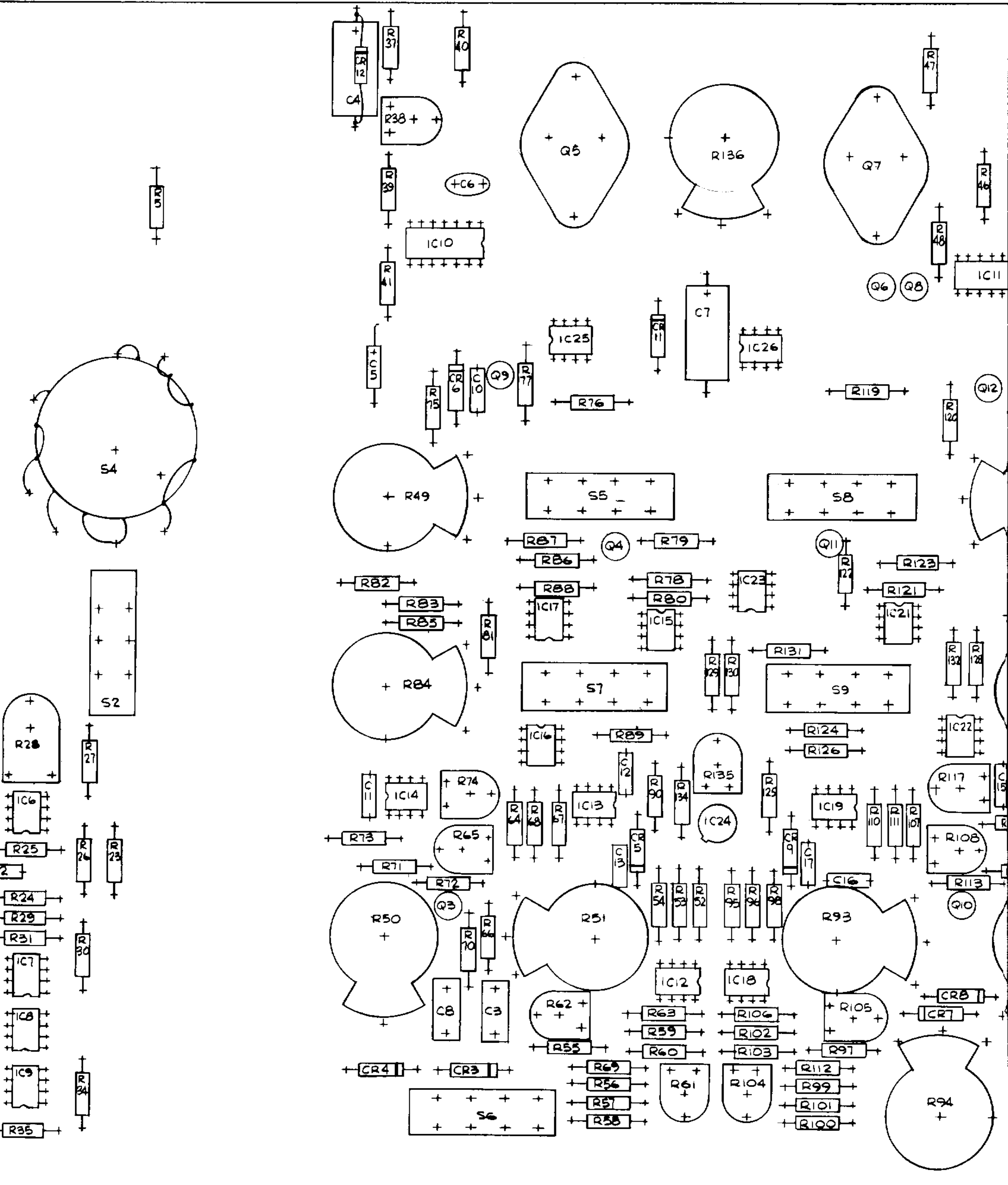



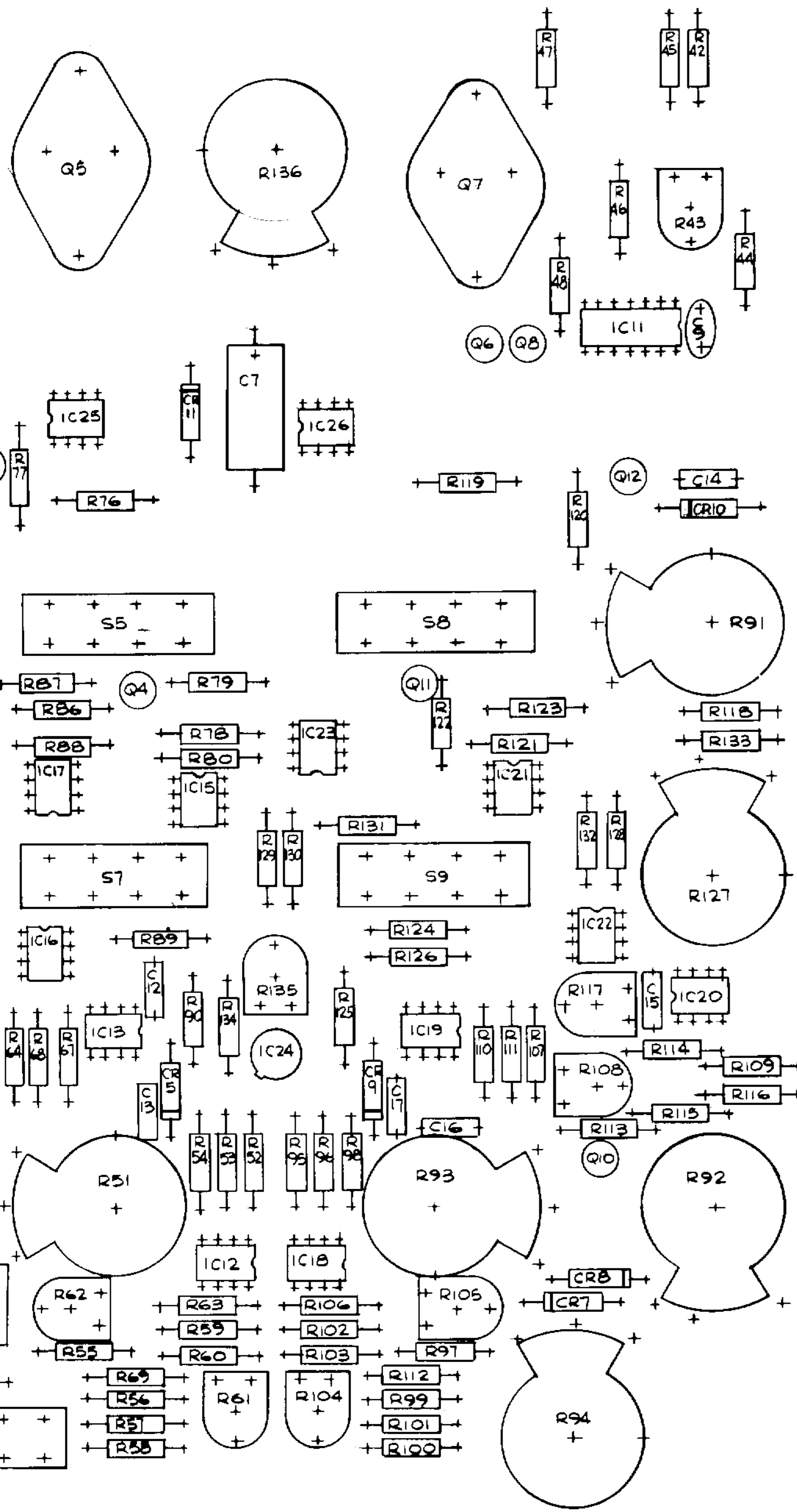

- 4
- 5
- 6
- 7
- 8
- 9

- 13
- 14
- 15
- A

- 5
- 6
- 7
- 8
- 9
- 10
- 11

- 13
- 14
- 15
- B

DRAWN BY JMP-9/13  
 CHECK RJF 9-73  
 GRP ENGR.  
 REVIEW QC.  
 SUPERVISOR  
 NEXT ASSY MODEL NO.  
 APPLICATION

**moog** WILLIAMSVILLE, NEW YORK  
 MUSIC INC.  
**SONIC SIX BOARD I**  
**COMPONENT LOCATION**  
 SIZE CODE IDENT 93-119  
 SCALE WT. SHEET OF

C  
1  
2  
3  
4  
5  
6  
7  
8  
9  
10  
11  
12  
13  
14  
15  
C

D  
1  
2  
3  
4  
5  
10  
11  
12  
13  
14  
15  
D

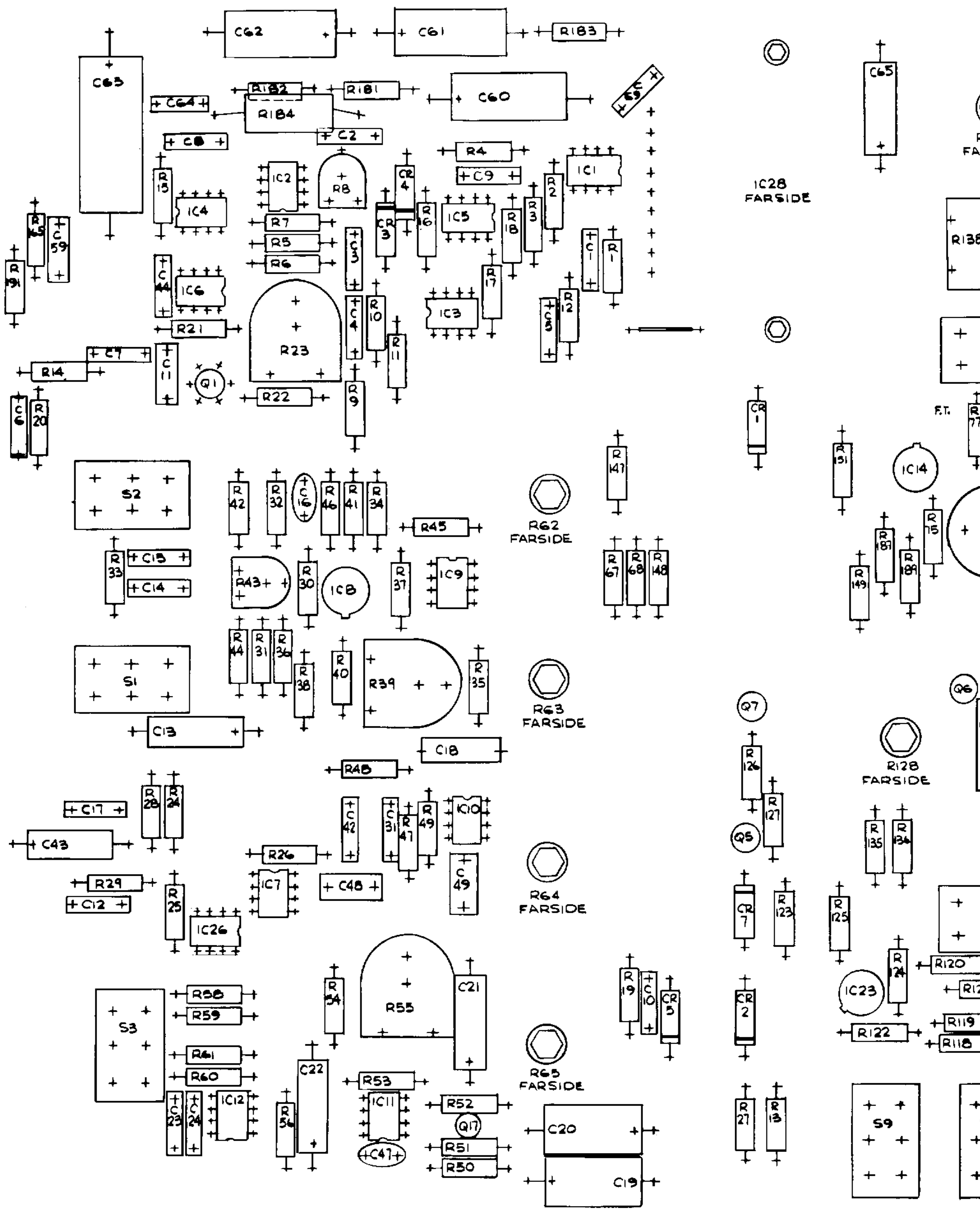

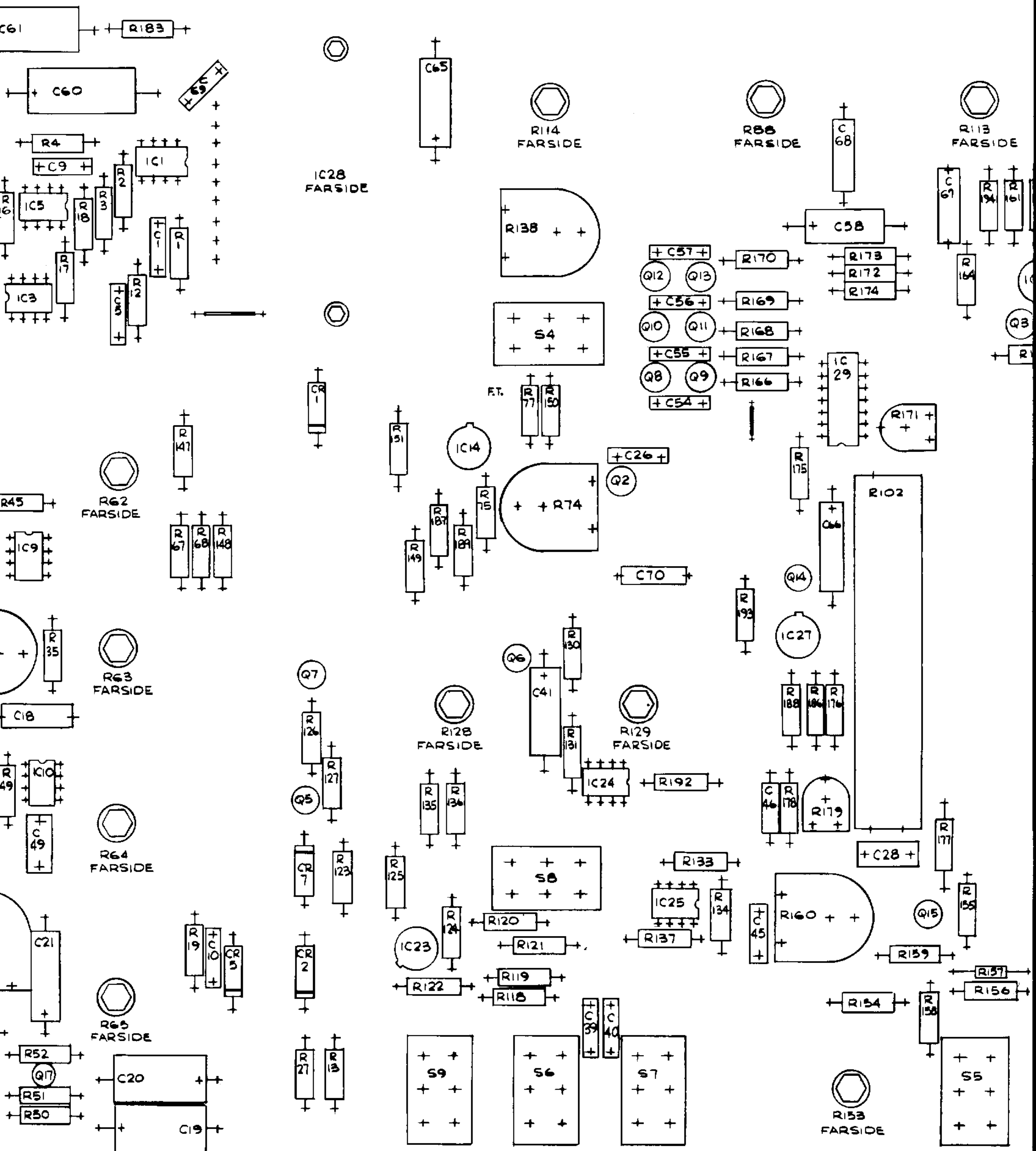

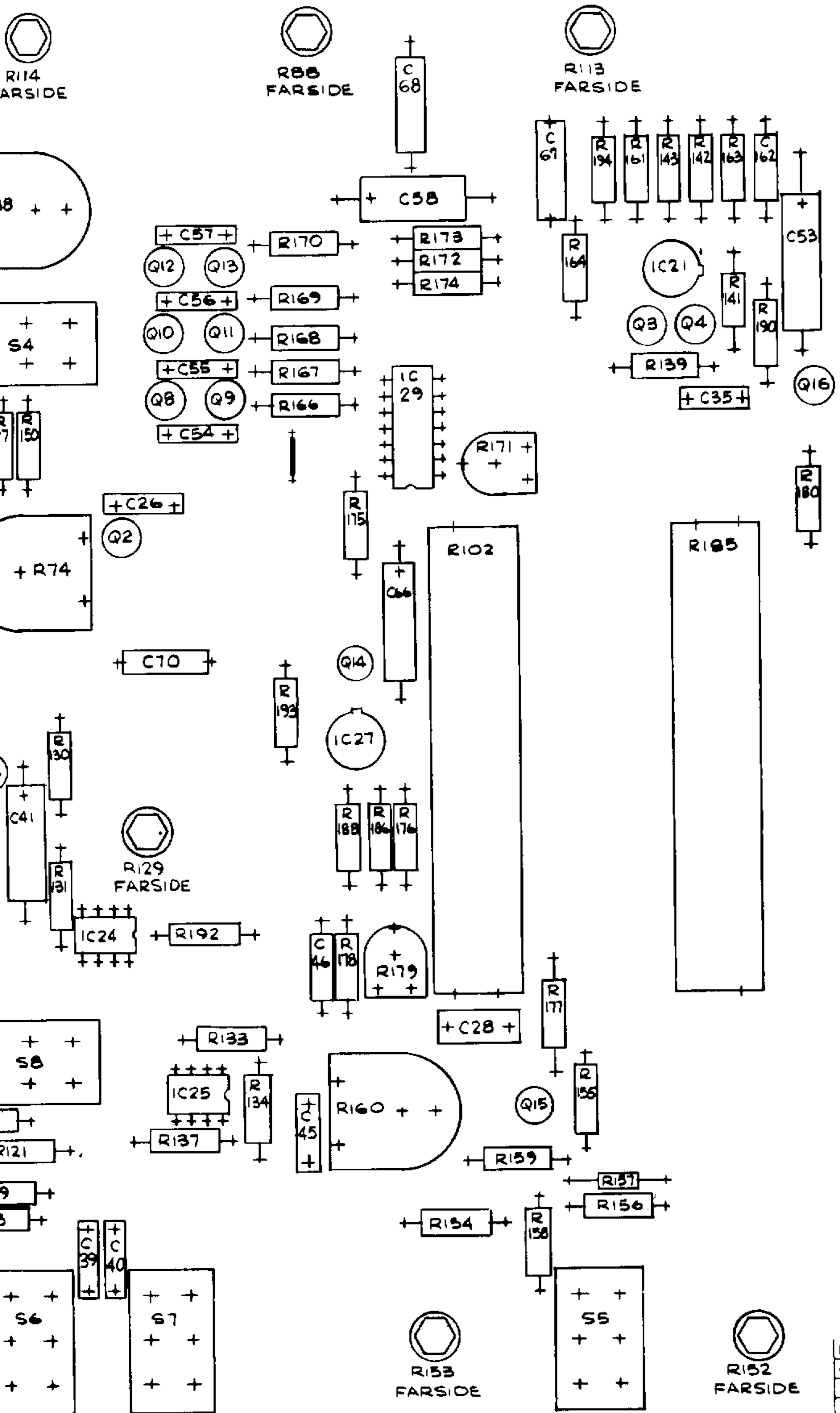

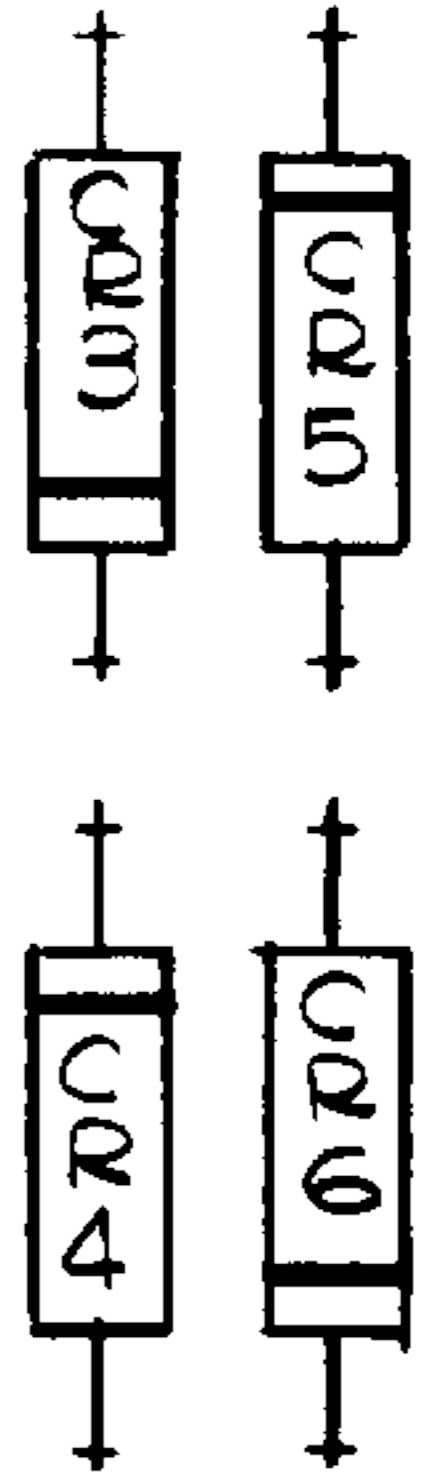
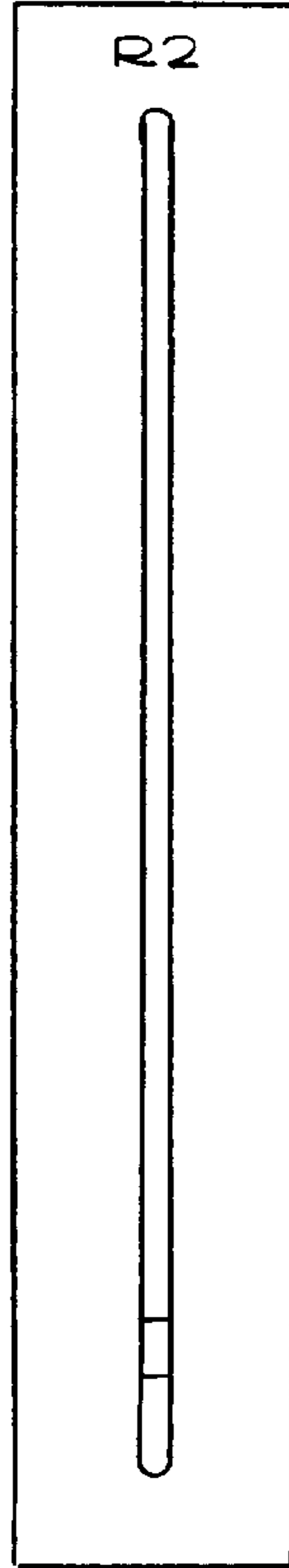
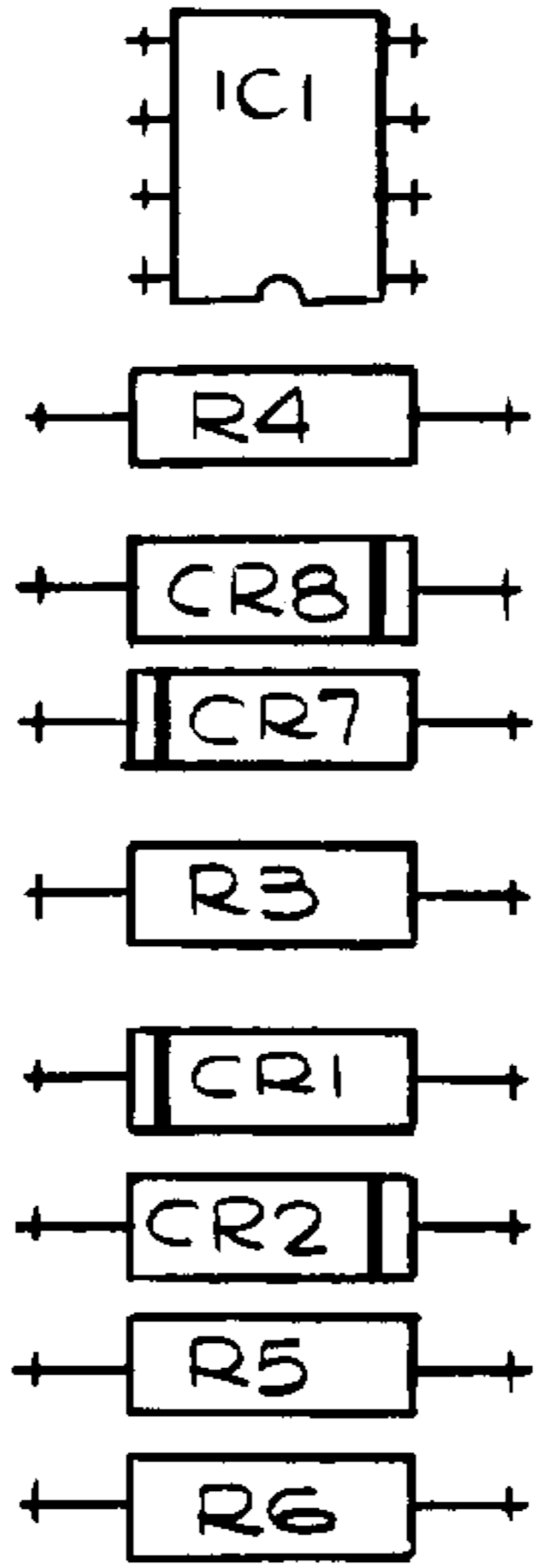
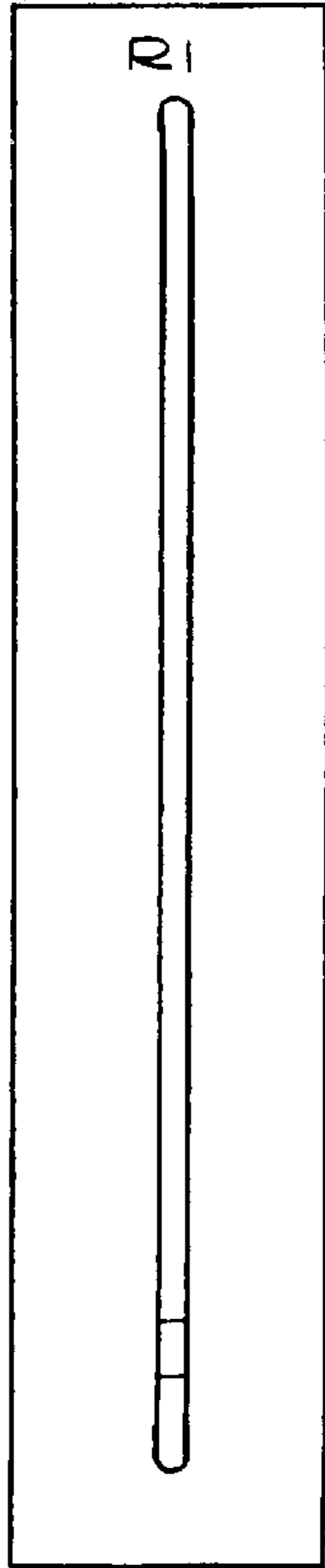

DRAWN BY: PREISLER 9/73		moog WILLIAMSVILLE, NEW YORK	
CHECK R/JF 9-73		SONIC SIX BOARD 2	
GRP ENGR.		COMPONENT LOCATION	
REVIEW QC.		SIZE	CODE IDENT
SUPERVISOR			93-120
NEXT ASSY	MODEL NO.	SCALE	WT.
APPLICATION			SHEET OF

- 1    ○ 2    ○ 3    ○ 4    ○ 5    ○ 6    ○ 7    ○ 8    ○ 9    ○ 10    ○ 11    ○ 12    ○ 13



ITEM	PART NUMBER	DESCRIPTION	MATERIAL		
UNLESS OTHERWISE SPECIFIED DIMENSIONS ARE IN INCHES TOLERANCE FRACTIONS : 1/64 ANGLES - 1/2° 3 PLACE DECIMALS : 005 2 PLACE DECIMALS : 01 125 FINISH ON ALL SURFACES  DRILLED HOLE TOL .040 - .125 DIA .002 Tool .126 - .228 DIA .003 Tool .229 - .500 DIA .004 Tool 500 - 750 DIA .005 Tool	DRAWN BY JMP 10/73		 WILLIAMSVILLE, NEW YORK  COMPONENT LOCATION SONIC SIX BOARD 3  SIZE CODE IDENT 93-127		
	CHECK R J F 10/73				
	GRP ENGR.				
	REVIEW QC.				
	SUPERVISOR				
	NEXT ASSY	MODEL NO.			
APPLICATION		SCALE	WT.	SHEET	OF

SECTION XI: Replacement Parts

<u>Moog Part Number</u>	<u>Description</u>
93-119	Board No. 1 (Oscillator)
93-120	Board No. 2 (Signal Proc.)
93-127	Board No. 3 (Pitch Bender)
93-008	Keyboard Assembly
74-253	Main Connector Wiring Harness
99-107	Carrying Case
93-003	Front Panel Ass'y (less boards)
37-028	2400 uf Electrolytic Capacitor
43-159	Power Transformer
51-053	2 Pole 4 Position Rotary Switch
51-505	DPDT Slide Switch
51-506	DPTT Slide Switch
51-508	DPDT Voltage Switch
51-202	DPDT Rocker Switch
51-510	Illuminated Rocker Switch
53-003	Knob-1½" Dia. Skirted
53-023	Knob-Slide Pot
53-024	Knob-Black Glamor Cap-Small
53-025	Knob-Black Glamor Cap-Large
53-026	Knob-Black Push On
54-105	Phone Jack-Non Shorting
54-106	Phone Jack-Shorting
54-107	Phone Jack-2 Circuit

SECTION XI: Replacement Parts (Continued)

<u>Moog Part Number</u>	<u>Description</u>
55-007	Socket - 6 Pin
55-342	Power Receptacle
57-004	Fuseholder
58-003	Speaker
61-112	Diode-IN4004
61-201	Diode-IN34A
61-211	Diode-IN4148
61-212	Diode-IN4738
62-407	Transistor-2N3055
62-415	Transistor-2N3904
62-416	Transistor-2N3906
62-533	Transistor-2N3954 (E400)
62-534	Transistor-NF510 (E112)
63-003	Integrated Circuit CA3080
63-004	Integrated Circuit 748
63-006	Integrated Circuit 796
63-009	Integrated Circuit 723
63-011	Integrated Circuit 914
63-012	Integrated Circuit 726
63-741	Integrated Circuit 741
63-743	Audio Power Amplifier
63-879	Integrated Circuit SG3821N
65-006	Selected TIS97 Transistor



SECTION XI: Replacement Parts (Continued)

<u>Moog Part Number</u>	<u>Description</u>
65-009	Selected 741 (A) Integrated Circuit
65-010	Selected 741 (B) Integrated Circuit
65-013	Matched Resistor Set-20K-10K
65-014	Matched Resistor Set-20K-20K
65-015	Matched Resistor Set-60.4K-30.1K-20K
65-016	Set of 49 Matched 100 ohm Resistors
65-028	Matched Resistors-20K-100K-100K-150K
74-011	Power Cord
95-027	Bottom Panel
95-028	Chassis-Pitch Bender
97-229	Wheel-Pitch Bender
25-023	1K ohm Resistor-Met Film-1 $\frac{1}{8}$ - $\frac{1}{4}$ W
25-031	3.32K "
25-037	15K "
25-044	100K "
25-048	301K "
25-062	10K "
25-069	3.01K "
25-070	12.1K "
25-072	4.99K "
25-085	357 ohm "
25-086	1.15K "
25-089	5.49K "
25-090	6.65K "

SECTION XI: Replacement Parts (Continued)

<u>Moog Part Number</u>	<u>Description</u>
25-091	18.7 ohm Resistor-Met Film-1%- $\frac{1}{4}$ W
25-092	19.1K "
25-093	20K "
25-094	30.1K "
25-075	60.4K " $\frac{1}{4}$ W
26-202	1K ohm Temp.Comp.Resistor
28-028	10K ohm Rotary Pot (Pitch Bender)
28-059	" Linear
28-060	" Lin W/Switch
28-060-1	" "
28-061	50K ohm Rotary Pot-Lin W/Switch
28-062	" Audio
28-063	100K " Lin W/Switch
28-064	1 Meg ohm Rotary Pot-Audio
28-065	100K " "
28-066	100K " Linear
28-119	100K ohm Carbon Trimpot
28-121	10K "
28-301	1K ohm Cermet Trimpot
28-302	2K "
28-303	100 "
28-304	500 "
28-305	10K "
28-306	200K "

SECTION XI: Replacement Parts (Continued)

<u>Moog Part Number</u>	<u>Description</u>
28-309	20Kohm Cermet Trimpot
28-310	200 "
28-401	10K ohm Slide Pot-Linear
28-402	100K "
28-403	100K " Audio
28-404	500K " Audio
28-405	50K " Audio

ORDER UNLISTED PARTS BY DESCRIPTION

SECTION XII: Modifications (For Units with S/N 1265 to 1300)

93-119 OSCILLATOR (Board 1)

To increase the input sensitivity of the oscillator "External Control Input" from 5 volts per octave to 1 volt per octave:

1. Change R58 and R100 from 100K 1% to 20K 1% metal film.

To prevent occasional "No-Start" condition, caused by latch-up of the positive regulator:

1. Add diode CR12, IN4148 from the plus 15 volt line to ground. Install diode "Piggy Back" on C4.

93-120 SIGNAL PROCESSING (Board 2)

To convert filter "External Control Input" to 1 volt per octave:

1. Change R157 from 43K 5% to 60.4K 1%.

93-127 PITCH BENDER (Board 3)

To increase the output swing of the pitch bender:

1. Change R6 from 100 K 5% to 43 K 5% carbon.

## SECTION XIII: Ordering and Shipping Instructions

### Ordering Parts

Most commonly used parts are listed in Section XI. When ordering, please include the Moog part number. If the part is not listed, order by description. Be as accurate as possible when describing what you want.

Example: Transistor, Q8 on Board 2.

### Returning Parts

All parts being returned should be accompanied with a "Return Material Tag". Eight of these tags are supplied with this manual; additional tags are free upon request. Fill the tag out as neatly and accurately as possible. Package the part being returned so that it will not be damaged in shipment. Circuit boards should be double wrapped and enclosed in a rigid cardboard box. Attach the "Return Material Tag" to the part, not to the shipping carton. If the entire unit is being returned, it must be shipped in the original carton, cartons may be obtained from the factory.

### Address

Use the following address for all orders and returns:

Moog Music, Inc.  
Academy Street PO Box 131  
Williamsville, New York 14221